

## 5. Rear Differential for VA-type

S303151

### A: REMOVAL S303151A18

- 1) Disconnect battery ground cable.
- 2) Move select lever or gear shift lever to "N".
- 3) Loosen wheel nuts.
- 4) Release the parking brake.
- 5) Jack-up vehicle and support it with sturdy racks.
- 6) Remove wheels.
- 7) Remove rear exhaust pipe and muffler.
- 8) Remove heat shield cover.

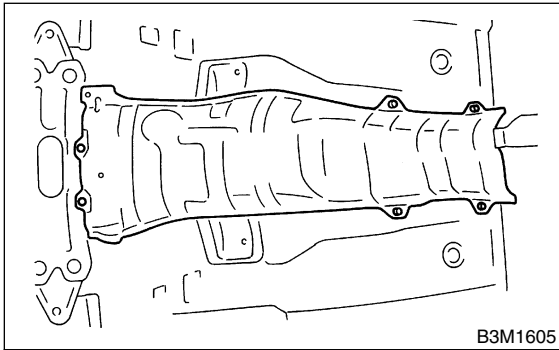

- 9) Remove propeller shaft.  
<Ref. to DS-13, REMOVAL, Propeller Shaft.>
- 10) Prepare a transmission jack and a band.

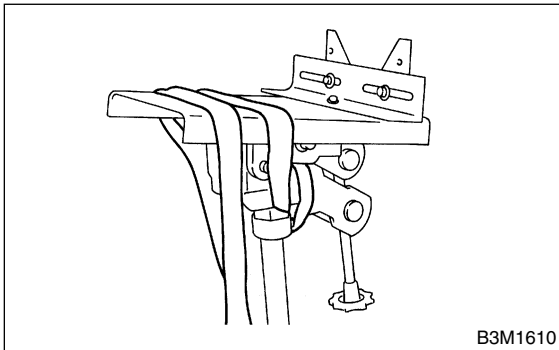

- 11) Loosen self-locking nuts connecting rear differential to rear crossmember.

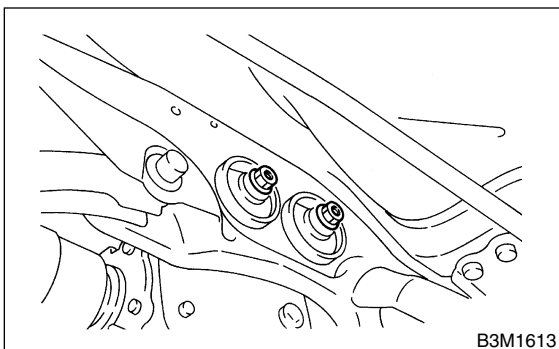

- 12) Remove DOJ of rear drive shaft from rear differential.

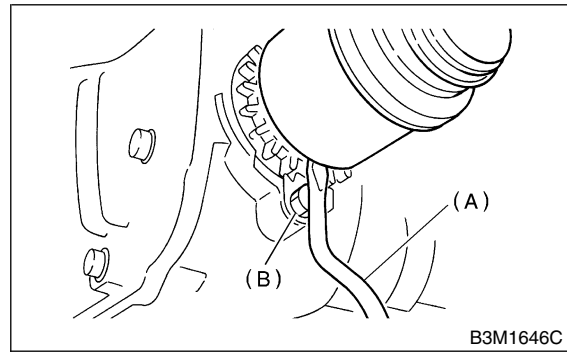

- (A) Tire lever  
(B) Bolt

- 13) Remove protector nut.

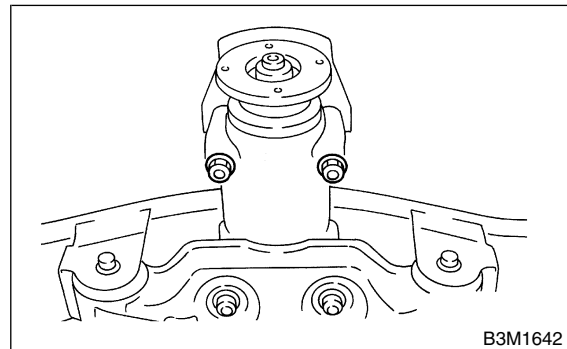

- 14) Remove nuts which secure rear differential front member.

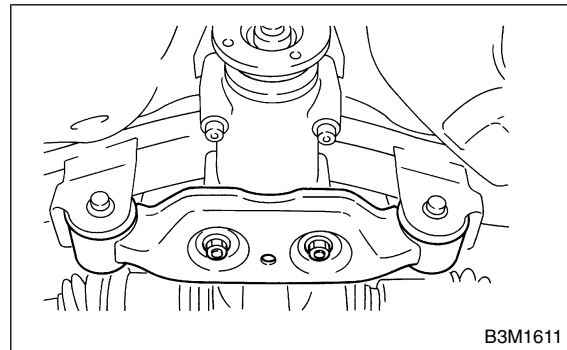

- 15) Support rear differential with transmission jack.

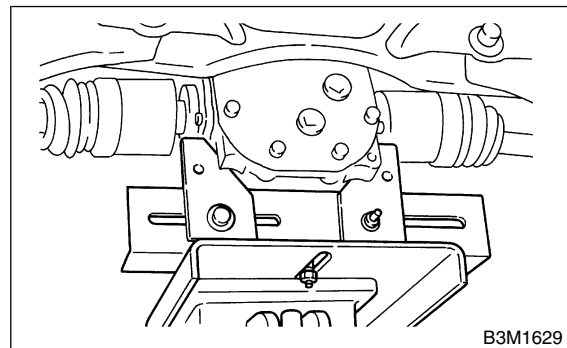

# REAR DIFFERENTIAL FOR VA-TYPE

## Differentials

- 16) Remove rear differential front member.
- 17) Fix rear differential at band.
- 18) Remove self-locking nuts connecting rear differential to rear crossmember.
- 19) Remove rear differential stud bolt from rear crossmember bushing.

### NOTE:

Carefully adjust angle and position of transmission jack and jack stand as required during stud bolt removal.

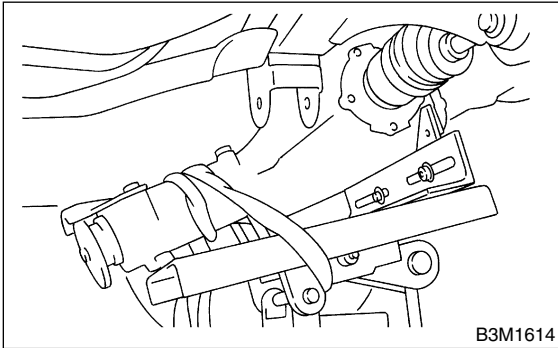

- 20) After removing rear differential stud bolt from rear crossmember, lower transmission jack stand. Do not allow rear drive shaft to strike lateral link bolt.

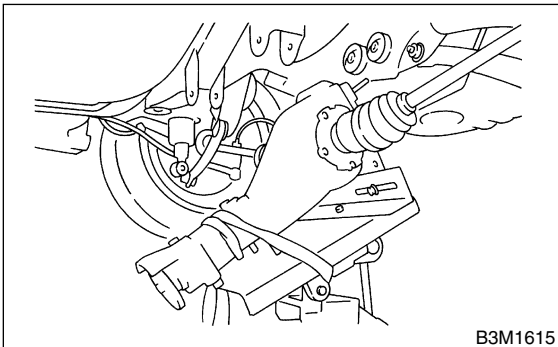

- 21) Pull out axle shaft from rear differential.

### NOTE:

If axle shaft is difficult to remove from rear differential, use a tire lever to remove it.

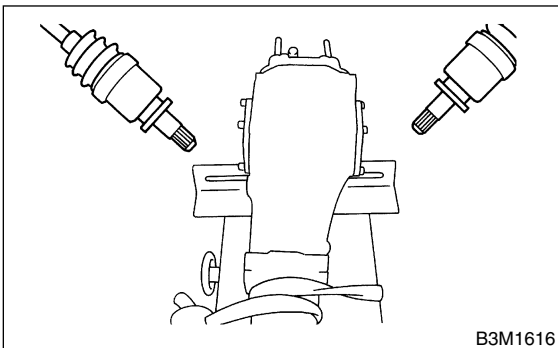

- 22) Take down transmission jack.
- 23) Secure rear drive shaft to lateral link using wire.

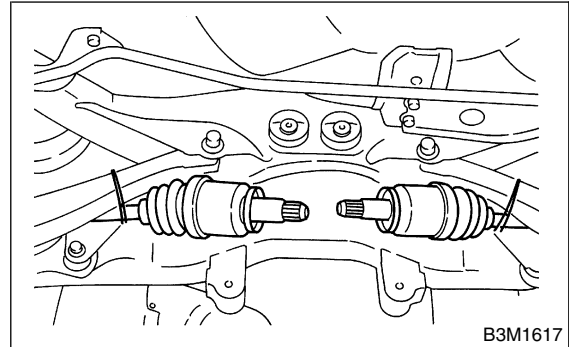

- 24) Remove protector and plate from rear differential.

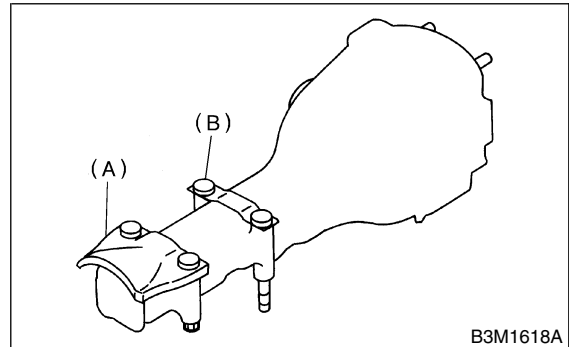

- (A) Protector
- (B) Rear differential member plate

## B: INSTALLATION S303151A11

- 1) Insert protector and plate to rear differential.

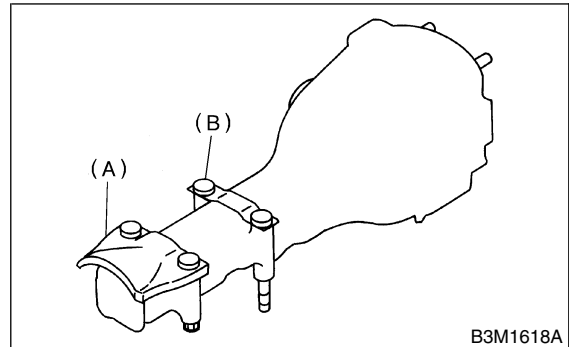

- (A) Protector
- (B) Rear differential member plate

# REAR DIFFERENTIAL FOR VA-TYPE

2) Set rear differential to transmission jack.

**NOTE:**

Secure rear differential to transmission jack using a band.

3) Install ST to rear differential.

ST 28099PA090 OIL SEAL PROTECTOR

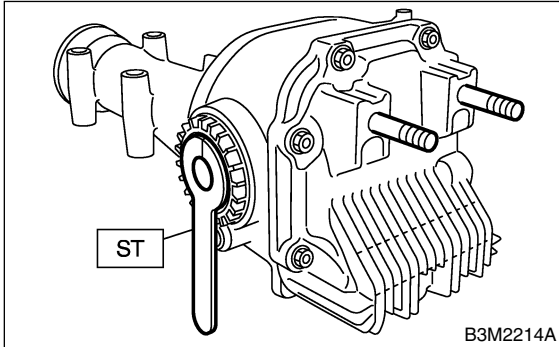

4) Insert the spline shaft until the spline portion is inside the side oil seal.

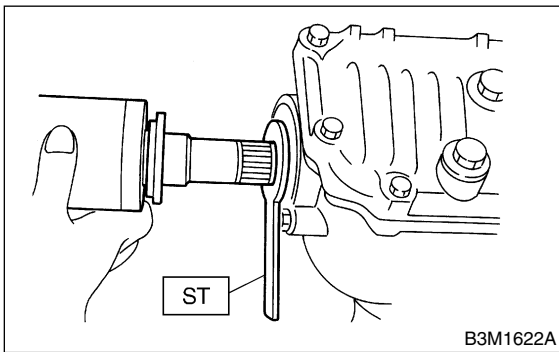

5) Remove ST from rear differential.

ST 28099PA090 OIL SEAL PROTECTOR

6) Completely insert axle shaft into rear differential by pressing rear differential.

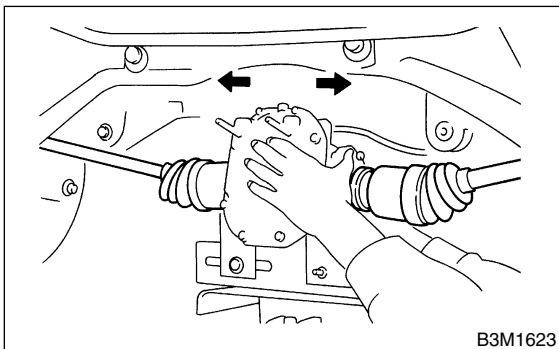

7) Adjust transmission jack as required so rear differential stud bolt is properly inserted into rear crossmember bushing.

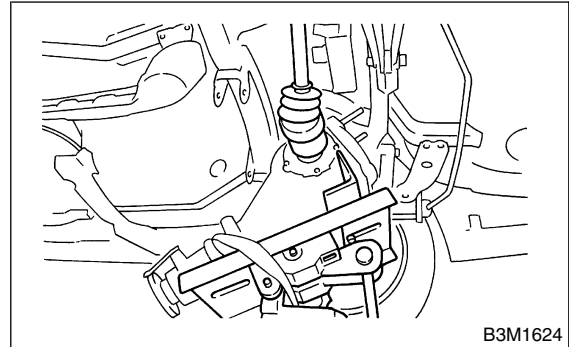

8) After rear differential stud bolt has been inserted into rear crossmember bushing, raise transmission jack to make jack rear differential level.

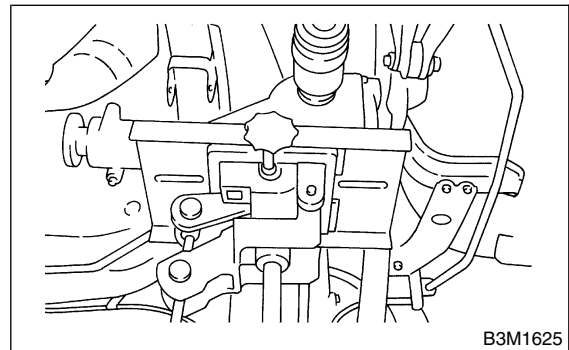

9) Temporarily tighten rear crossmember self-locking nuts.

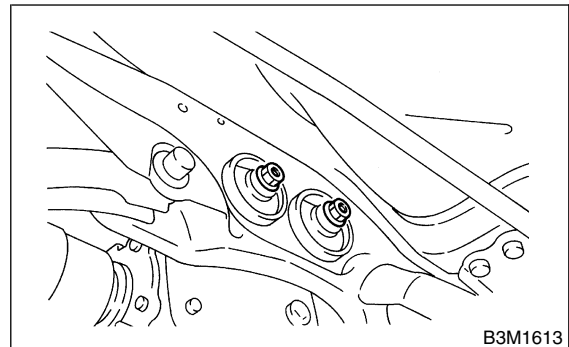

# REAR DIFFERENTIAL FOR VA-TYPE

## Differentials

10) Remove band from rear differential. Raise rear differential just enough to move transmission jack away from it.

11) Install differential member.

### Tightening torque:

**T1: 65 N·m (6.6 kgf-m, 48 ft-lb)**

**T2: 110 N·m (11.2 kgf-m, 81 ft-lb)**

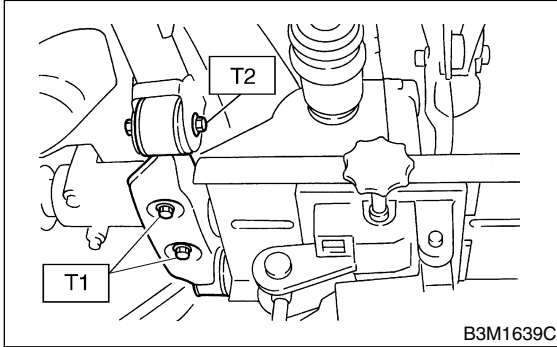

12) Tighten self-locking nut.

### Tightening torque:

**70 N·m (7.1 kgf-m, 51 ft-lb)**

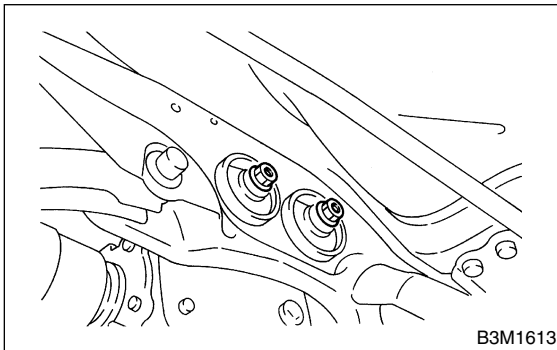

13) Tighten protector nut.

### Tightening torque:

**64 N·m (6.5 kgf-m, 47.0 ft-lb)**

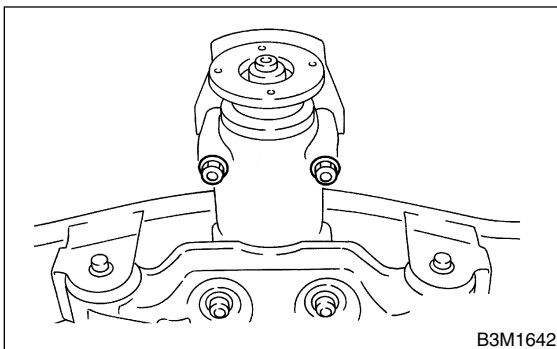

14) Take down transmission jack.

15) Install propeller shaft.

<Ref. to DS-14, INSTALLATION, Propeller Shaft.>

16) Install heat shield cover.

17) Install rear exhaust pipe and muffler.

18) After installing rear differential carrier on vehicle, remove filler plug and replenish gear oil up to upper level mark.

### Oil capacity:

**0.9 l (1.0 US qt, 0.8 Imp qt)**

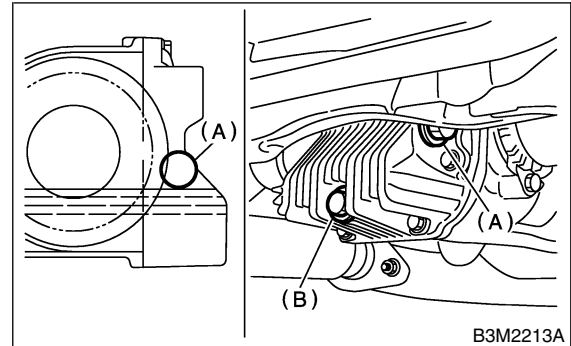

(A) Filler plug

(B) Drain plug

19) Tighten filler plug.

### NOTE:

Be sure to use a new aluminum gasket.

### Tightening torque:

**34 N·m (3.5 kgf-m, 25.3 ft-lb)**

20) Install rear differential protector. (if equipped)

## C: DISASSEMBLY S303151A06

To detect real cause of trouble, inspect the following items before disassembling.

- Tooth contact of crown gear and pinion, and backlash
- Runout of crown gear at its back surface
- Turning resistance of drive pinion

1) Set ST on vise and install the differential assembly to ST.

ST 398217700 ATTACHMENT

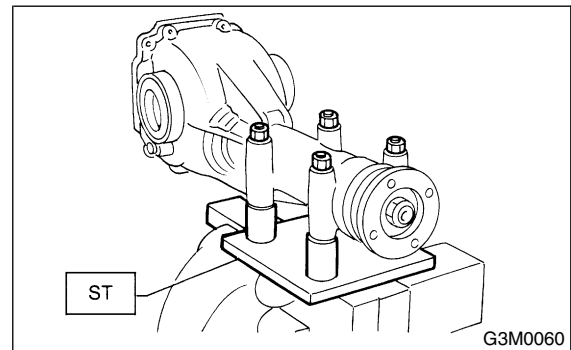

2) Drain gear oil by removing plug.

3) Remove rear cover by loosening retaining bolts.

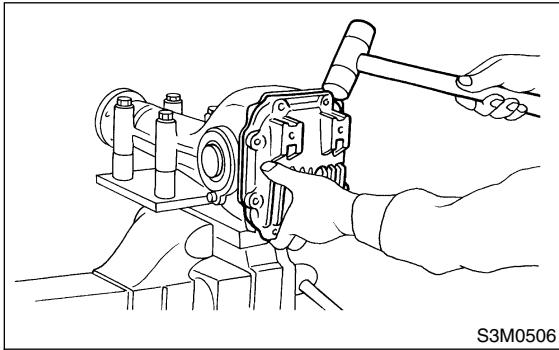

4) Replace air breather cap.

NOTE:

Do not attempt to replace the air breather cap unless necessary.

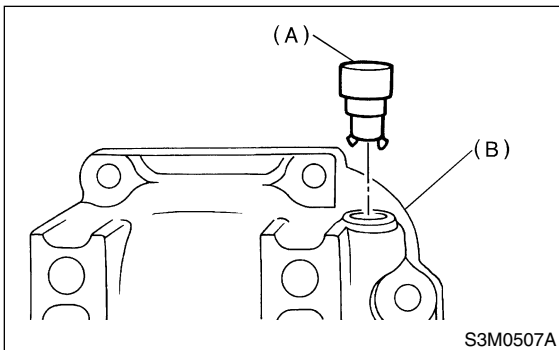

- (A) Air breather cap
- (B) Rear cover

5) Remove right and left lock plates.

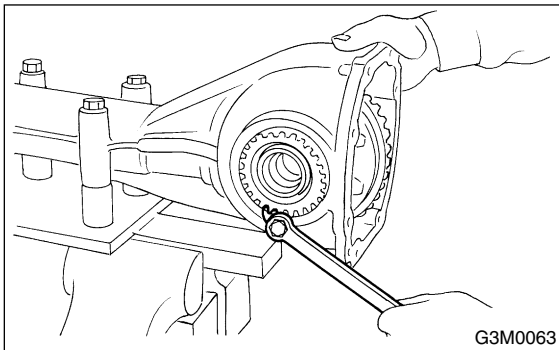

6) Remove right and left holders with ST.  
ST 399780111 WRENCH

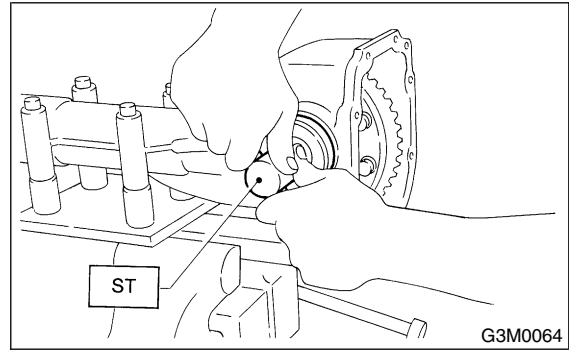

7) Pull out differential assembly from differential case.

NOTE:

Be careful not to hit the teeth against the case.

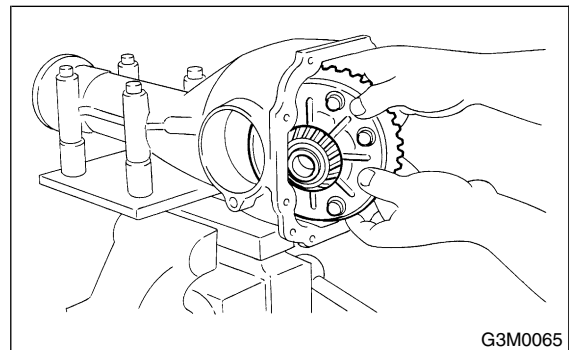

8) Remove bearing race from right and left holders with ST1 and ST2.

ST1 499705401 BEARING OUTER RACE PULLER ASSY

ST2 499705404 OUTER RACE PULLER SEAT

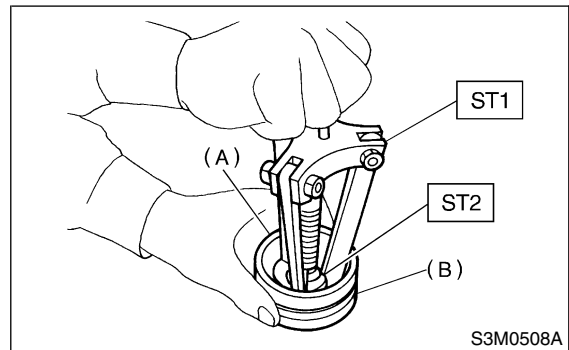

- (A) Bearing race
- (B) Holder

# REAR DIFFERENTIAL FOR VA-TYPE

## Differentials

9) Remove oil seal from right and left holders with screwdriver.

**NOTE:**

Perform this operation only when changing oil seal.

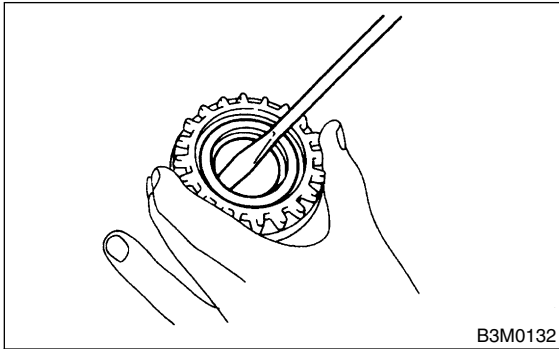

10) Extract bearing cone with ST1 and ST2.

**NOTE:**

- Do not attempt to disassemble the parts unless necessary.
- Set Puller so that its claws catch the edge of the bearing cone.
- Never mix up the right and left hand bearing races and cones.

ST1 899524100 PULLER SET  
ST2 399520105 SEAT

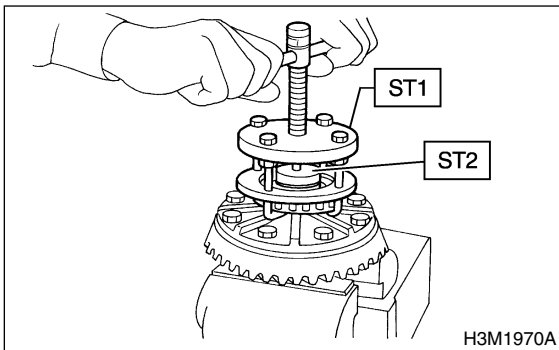

11) Remove crown gear by loosening crown gear bolts.

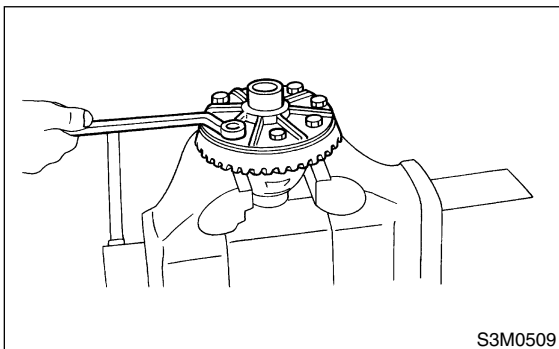

12) Drive out pinion shaft lock pin from crown gear side.

**NOTE:**

The lock pin is staked at the pin hole end on the differential case; do not drive it out forcibly before unstaking it.

ST 899904100 STRAIGHT PIN REMOVER

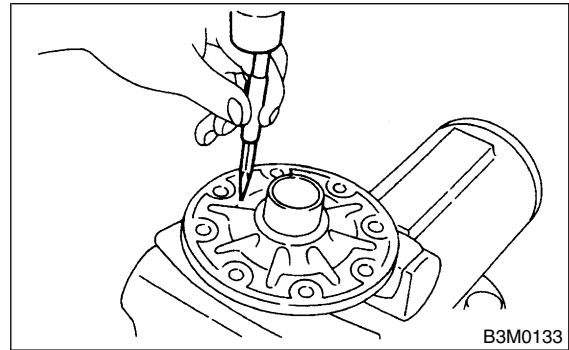

13) Draw out pinion mate shaft and remove pinion mate gears, side gears and thrust washers.

**NOTE:**

The gears as well as thrust washers should be marked or kept separated left and right, and front and rear.

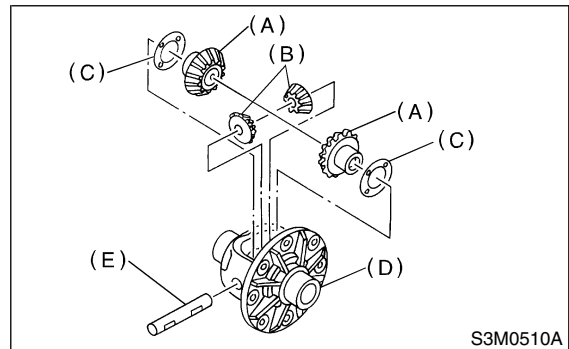

- (A) Side gear
- (B) Pinion mate gear
- (C) Thrust washer
- (D) Differential case
- (E) Pinion mate shaft

14) Hold companion flange with ST and remove self-locking nut.

ST 498427200 FLANGE WRENCH

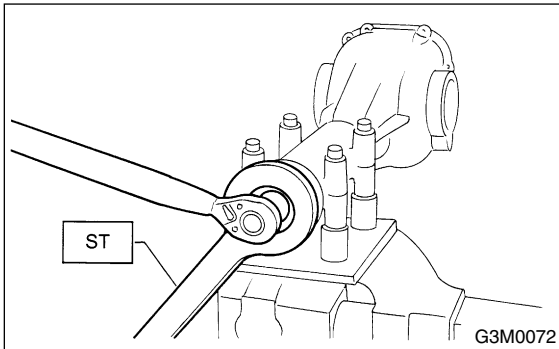

15) Extract the companion flange with a puller.

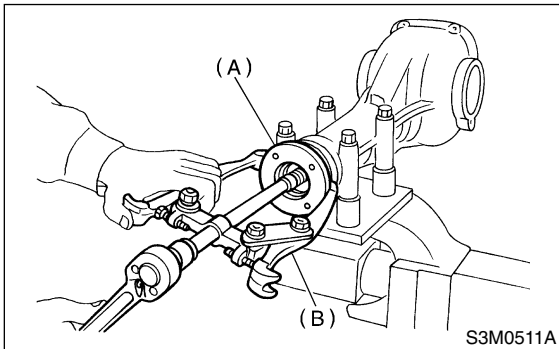

- (A) Companion
- (B) Puller

16) Press the end of drive pinion shaft and extract it together with rear bearing cone, preload adjusting spacer and washer.

NOTE:

Hold the drive pinion so as not to drop it.

ST 398467700 DRIFT

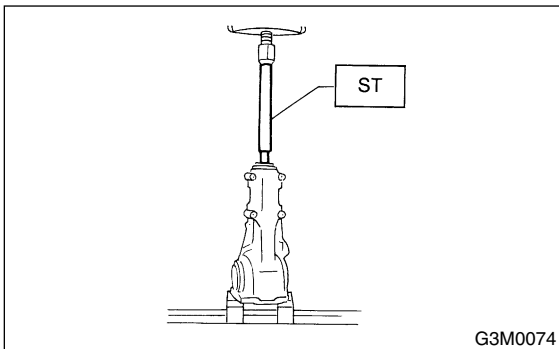

17) Remove rear bearing cone from drive pinion by supporting cone with ST.

NOTE:

Place the replacer so that its center-recessed side faces the pinion gear.

ST 498515500 REPLACER

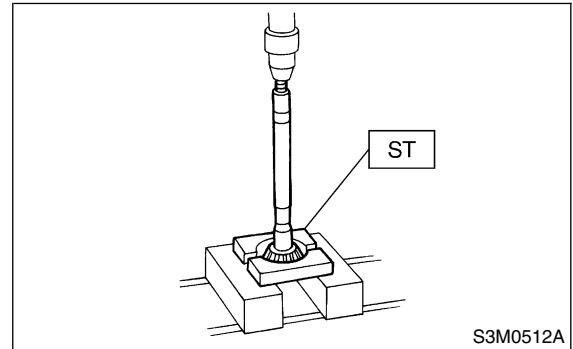

18) Remove front oil seal from differential carrier using ST.

ST 398527700 PULLER ASSY

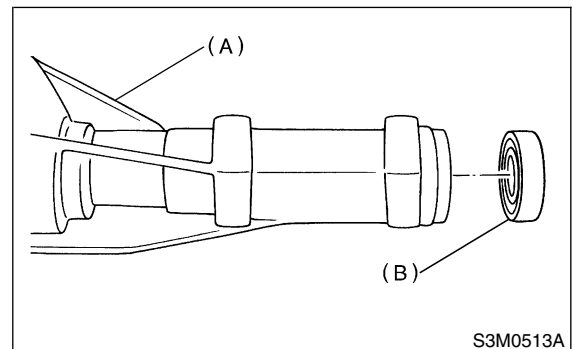

- (A) Differential carrier
- (B) Front oil seal

19) Remove pilot bearing together with front bearing cone using ST.

ST 398467700 DRIFT

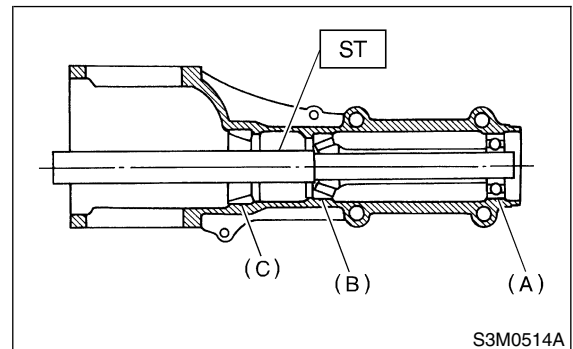

- (A) Pilot bearing
- (B) Front bearing
- (C) Rear bearing cup

# REAR DIFFERENTIAL FOR VA-TYPE

## Differentials

20) When replacing bearings, tap front bearing cup and rear bearing cup in this order out of case by using a brass bar.

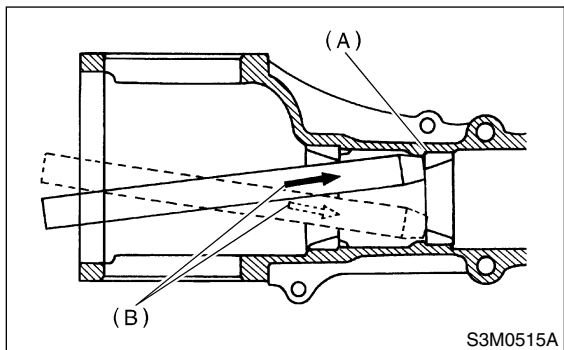

- (A) 2 cutouts along diagonal lines
- (B) Tap alternately with brass bar.

## D: ASSEMBLY S303151A02

### 1) Precautions for assembling

- Assemble in the reverse order of disassembling.
- Check and adjust each part during assembly.
- Keep the shims and washers in order, so that they are not misinstalled.
- Thoroughly clean the surfaces on which the shims, washers and bearings are to be installed.
- Apply gear oil when installing the bearings and thrust washers.
- Be careful not to mix up the right and left hand races of the bearings.
- Replace the oil seal with new one at every disassembly. Apply chassis grease between the lips when installing the oil seal.

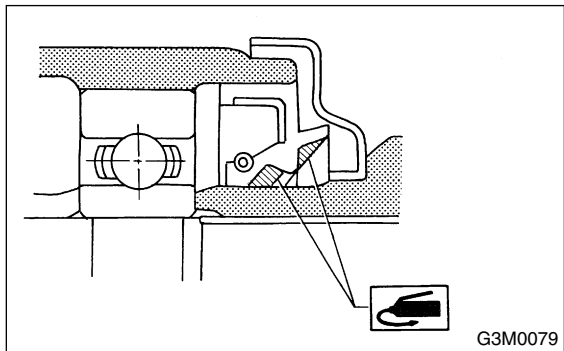

2) Adjust preload for front and rear bearings. Adjust the bearing preload with spacer and washer between front and rear bearings. Pinion height adjusting washer are not affected by this adjustment. The adjustment must be carried out without oil seal inserted.

(1) Press rear bearing race into differential carrier with ST1 and ST2.

ST1 398477701 HANDLE  
ST2 398477702 DRIFT

(2) Press front bearing race into differential carrier with ST1 and ST2.

ST1 398477701 HANDLE  
ST2 498447110 DRIFT

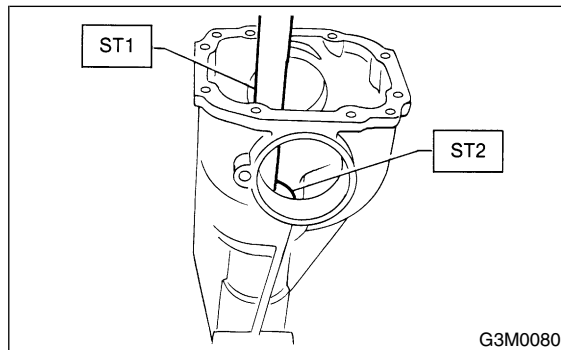

- (3) Insert a new front bearing cone.
- (4) Insert ST1 into case with pinion height adjusting shim and new rear bearing cone fitted onto it.

### NOTE:

Re-use the used washer if not deformed.

(5) Then install preload adjusting spacer and washer, front bearing cone, ST2, companion flange, and washer and self-locking nut.

ST1 498447150 DUMMY SHAFT  
ST2 32285AA000 DUMMY COLLAR

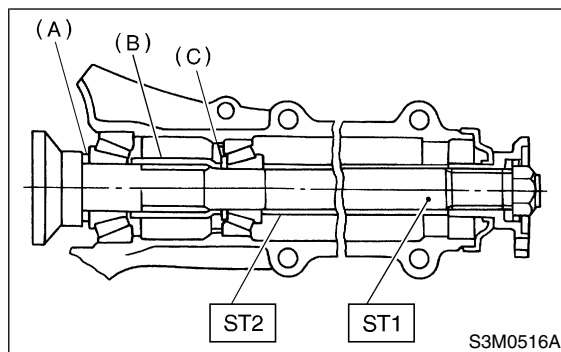

- (A) Pinion height adjusting shim
- (B) Preload adjusting spacer
- (C) Preload adjusting washer



(6) Turn ST1 with hand to make it seated, and tighten drive pinion nut while measuring the preload with spring balance. Select preload adjusting washer and spacer so that the specified preload is obtained when nut is tightened to the specified torque.

**NOTE:**

- Use a new self-locking nut.
- Be careful not to give excessive preload.
- When tightening the drive pinion nut, lock ST1 with ST2 as shown in the figure.

ST1 398507704 BLOCK  
ST2 498447150 DUMMY SHAFT

**Tightening torque:**  
**188 N·m (19.2 kgf·m, 139 ft·lb)**

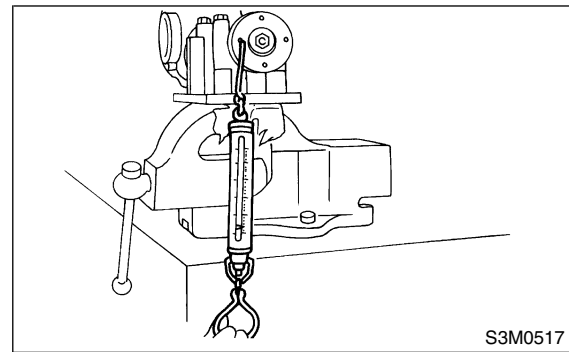
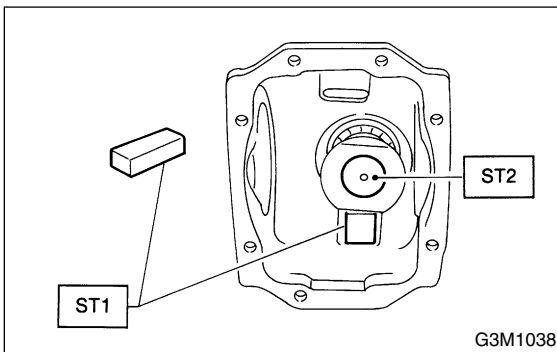

Front and rear bearing preload
For new bearing: 12.7 — 32.4 N (1.3 — 3.3 kgf, 2.9 — 7.3 lb) at companion flange bolt hole

	Part No.	Thickness mm (in)
Preload adjusting washer	38336AA000	1.500 (0.0591)
	38336AA120	1.513 (0.0596)
	38336AA010	1.525 (0.0600)
	38336AA130	1.538 (0.0606)
	38336AA020	1.550 (0.0610)
	38336AA140	1.563 (0.0615)
	38336AA030	1.575 (0.0620)
	38336AA150	1.588 (0.0625)
	38336AA040	1.600 (0.0630)
	38336AA160	1.613 (0.0635)
	38336AA050	1.625 (0.0640)
	38336AA170	1.638 (0.0645)
	38336AA060	1.650 (0.0650)
	38336AA180	1.663 (0.0655)
	38336AA070	1.675 (0.0659)
	38336AA190	1.688 (0.0665)
	38336AA080	1.700 (0.0669)
	38336AA200	1.713 (0.0674)
	38336AA090	1.725 (0.0679)
	38336AA210	1.738 (0.0684)
38336AA100	1.750 (0.0689)	
38336AA220	1.763 (0.0694)	
38336AA110	1.775 (0.0699)	
	Part No.	Length mm (in)
Preload adjusting spacer	32288AA040	52.3 (2.059)
	32288AA050	52.5 (2.067)
	31454AA100	52.6 (2.071)
	32288AA060	52.7 (2.075)
	31454AA110	52.8 (2.079)
	32288AA070	52.9 (2.083)
	31454AA120	53.0 (2.087)
	32288AA080	53.1 (2.091)
	32288AA090	53.3 (2.098)

# REAR DIFFERENTIAL FOR VA-TYPE

## Differentials

### 3) Adjusting drive pinion height

Adjust drive pinion height with shim installed between rear bearing cone and the back of pinion gear.

- (1) Install ST1, ST2 and ST3, as shown in the figure, and apply the specified preload on the bearings

Front and rear bearing preload
For new bearing: 12.7 — 32.4 N (1.3 — 3.3 kgf, 2.9 — 7.3 lb) at companion flange bolt hole

Adjusting preload for front and rear bearings

#### NOTE:

At this time, install an original pinion height adjusting shim.

- ST1 498447150 DUMMY SHAFT  
ST2 32285AA000 DUMMY COLLAR  
ST3 498505501 DIFFERENTIAL CARRIER GAUGE

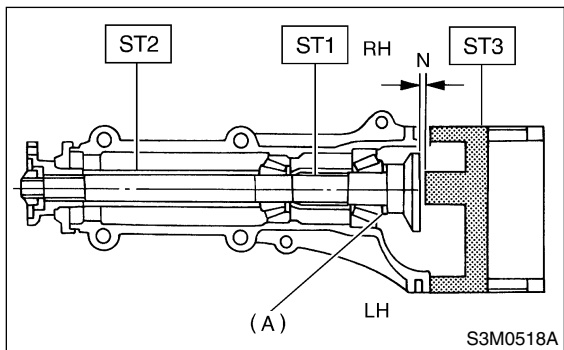

(A) Pinion height adjusting shim

- (2) Measure the clearance N between the end of ST3 and the end surface of ST1 by using a thickness gauge.

#### NOTE:

Make sure there is no clearance between the case and ST3.

- ST1 498447150 DUMMY SHAFT  
ST2 498505501 DIFFERENTIAL CARRIER GAUGE

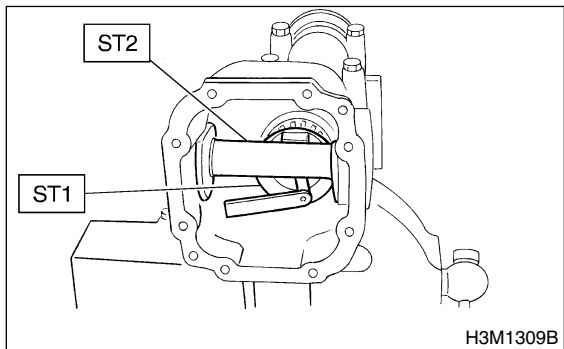

- (3) Obtain the thickness of pinion height adjusting washer to be inserted from the following formula, and replace the temporarily installed shim with this one.

#### NOTE:

Use 1 to 3 shims as required for adjustment.

$$T = T_o + N - 0.05 \text{ (mm)}$$

where

T = Thickness of pinion height adjusting shim (mm)

T<sub>o</sub> = Thickness of shim originally installed (mm)

N = Reading of thickness gauge (mm)

H = Figure marked on drive pinion head  
(Example of calculation)

$$T_o = 0.15 \text{ mm}$$

$$N = 0.1 \text{ mm}$$

$$T = 0.15 + 0.1 - 0.05 = 0.2 \text{ mm}$$

Result: Thickness = 0.2 mm

Therefore use the 32295AA220.

Pinion height adjusting shim	
Part No.	Thickness mm (in)
32295AA200	0.150 (0.0059)
32295AA210	0.175 (0.0069)
32295AA220	0.200 (0.0079)
32295AA230	0.225 (0.0089)
32295AA240	0.250 (0.0098)
32295AA250	0.275 (0.0108)

- (4) Install the selected pinion height adjusting shim on drive pinion, and press the rear bearing cone into position with ST.

ST 498175500 INSTALLER

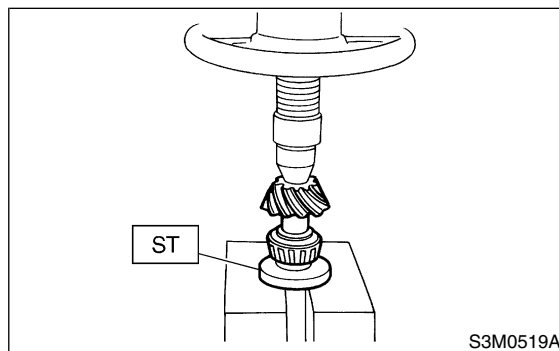

5) Insert drive pinion into differential carrier, install the previously selected bearing preload adjusting spacer and washer.

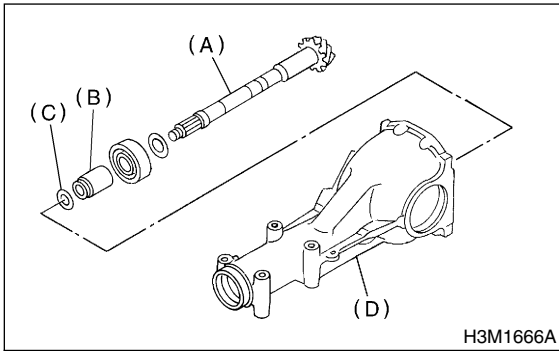

- (A) Drive pinion
- (B) Bearing preload adjusting spacer
- (C) Bearing preload adjusting washer
- (D) Differential carrier

6) Press-fit front bearing cone into carrier with ST1, ST2 and ST3.

- ST1 32285AA000 DUMMY COLLAR
- ST2 399780104 WEIGHT
- ST3 899580100 INSTALLER

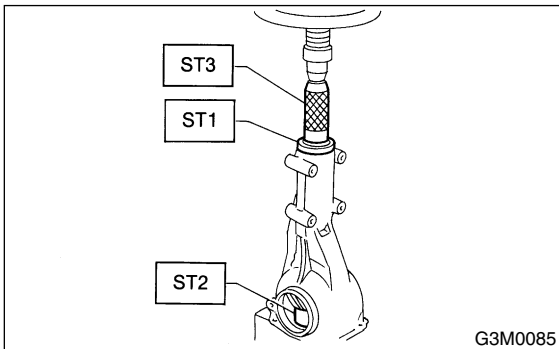

7) Insert spacer, then press-fit pilot bearing with ST1 and ST2.

- ST1 399780104 WEIGHT
- ST2 899580100 INSTALLER

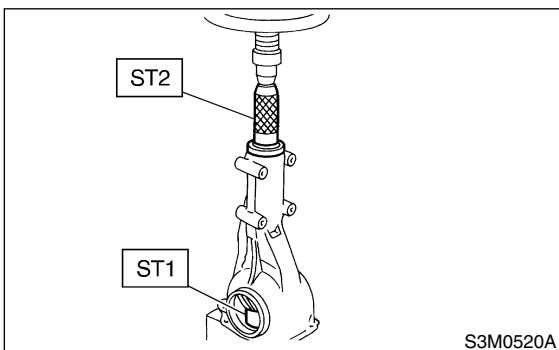

8) Fit a new oil seal with ST.

NOTE:

- Press-fit until end of oil seal is 1 mm (0.04 in) inward from end of carrier.
- Apply grease between the oil seal lips.

ST 498447120 OIL SEAL INSTALLER

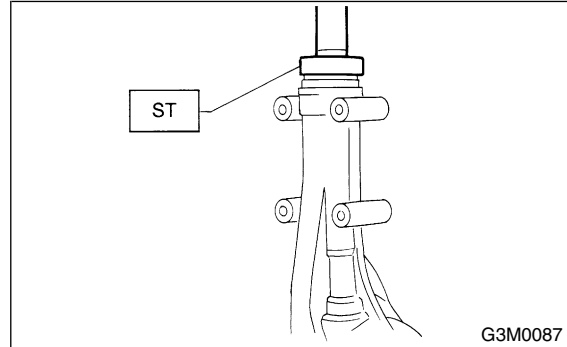

9) Press-fit companion flange with ST1 and ST2.

NOTE:

Be careful not to damage bearing.

- ST1 899874100 INSTALLER
- ST2 399780104 WEIGHT

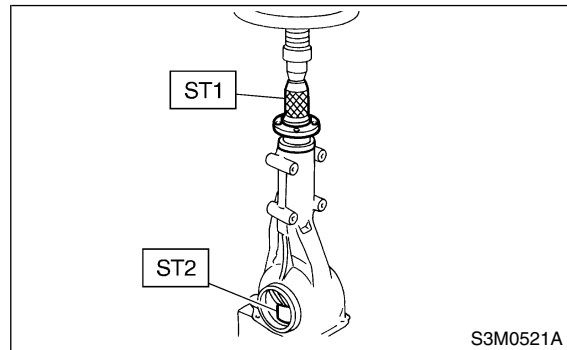

10) Install self-locking nut. Then tighten it with ST.

ST 398427200 FLANGE WRENCH

**Tightening torque:**  
**188 N·m (19.2 kgf·m, 139 ft·lb)**

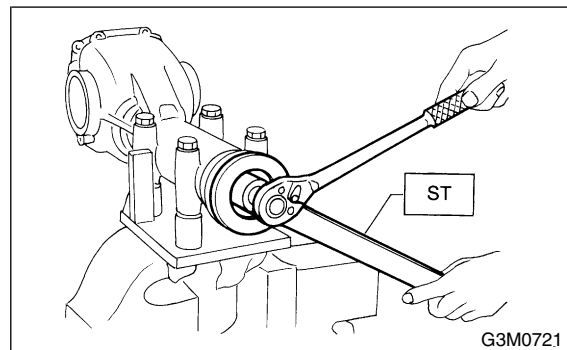

# REAR DIFFERENTIAL FOR VA-TYPE

## Differentials

11) Assembling differential case  
Install side gears and pinion mate gears, with their thrust washers and pinion mate shaft, into differential case.

**NOTE:**

- Apply gear oil on both sides of the washer and on the side gear shaft before installing.
- Insert the pinion mate shaft into the differential case by aligning the lock pin holes.

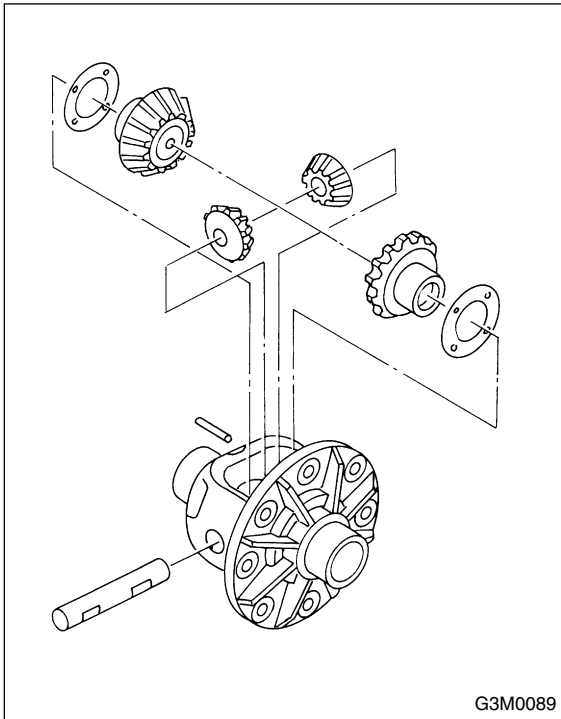

G3M0089

(1) Measure the side gear backlash.

**Side gear back clearance:**  
**0.05 — 0.15 mm (0.0020 — 0.0059 in)**

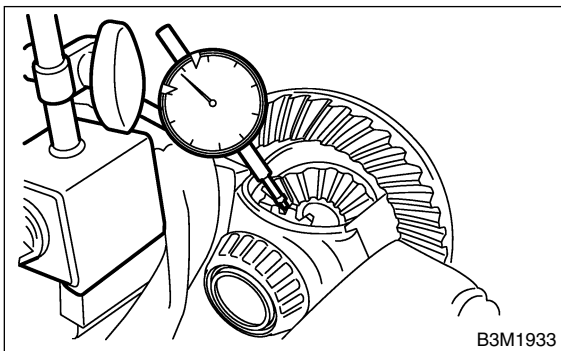

B3M1933

(2) Adjust the side gear backlash as specified by selecting side gear thrust washer.

Side gear thrust washer	
Part No.	Thickness mm (in)
803135011	0.925 — 0.950 (0.0364 — 0.0374)
803135012	0.950 — 0.975 (0.0374 — 0.0384)
803135013	0.975 — 1.000 (0.0384 — 0.0394)
803135014	1.000 — 1.025 (0.0394 — 0.0404)
803135015	1.025 — 1.050 (0.0404 — 0.0413)

(3) Check the condition of rotation after applying oil to the gear tooth surfaces and thrust surfaces.

(4) After driving in pinion shaft lock pin, stake the both sides of the hole to prevent pin from falling off.

(5) Install crown gear on differential case.

**NOTE:**

- Before installing bolts, apply Lock Tite to bolt threads.

**Lock Tite**

**THREE BOND 1324 or equivalent**

- Tighten diagonally while tapping the bolt heads.

**Tightening torque:**

**62 N·m (6.3 kgf·m, 45.6 ft·lb)**

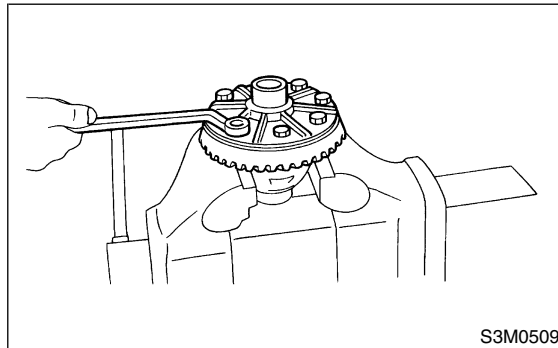

S3M0509

12) Press side bearing cone onto differential case with ST.

ST 498485400 DRIFT

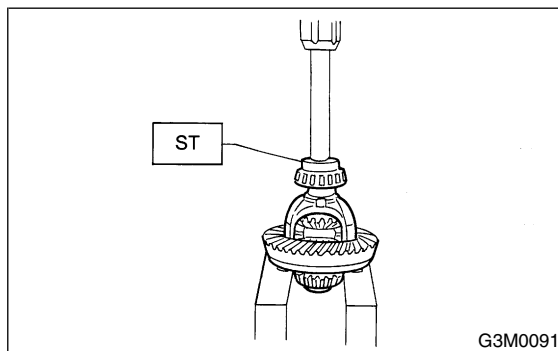

G3M0091

13) Assemble holders.

(1) Install oil seal into right and left holders.

ST 498447100 AXLE SHAFT OIL SEAL  
INSTALLER

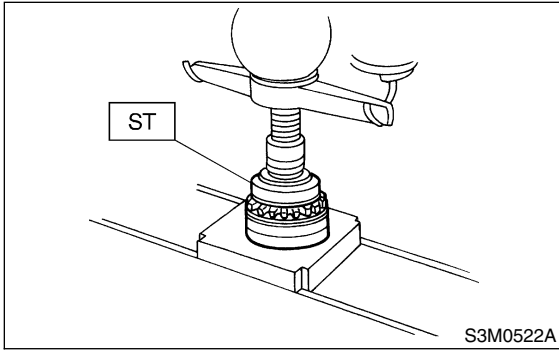

(2) Install bearing race into right and left holders.

ST 398477702 BEARING OUTER RACE  
DRIFT

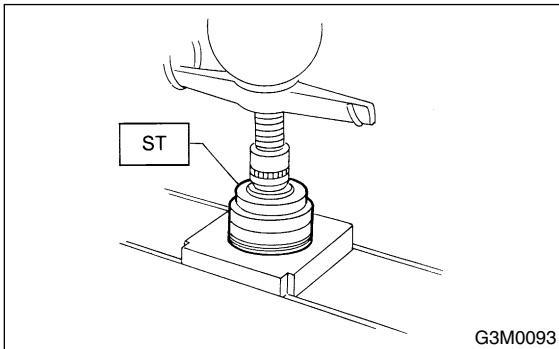

(3) Install the differential case assembly into differential carrier in the reverse order of disassembly.

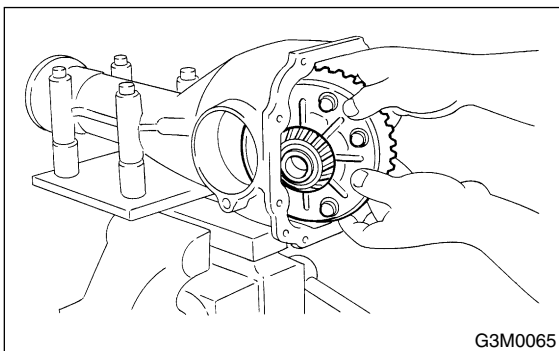

14) Perform adjustment of backlash of pinion crown gear set and adjustment of preload of differential side bearing.

(1) Turn drive pinion with ST for better fitting of differential side bearing.

ST 498427200 FLANGE WRENCH

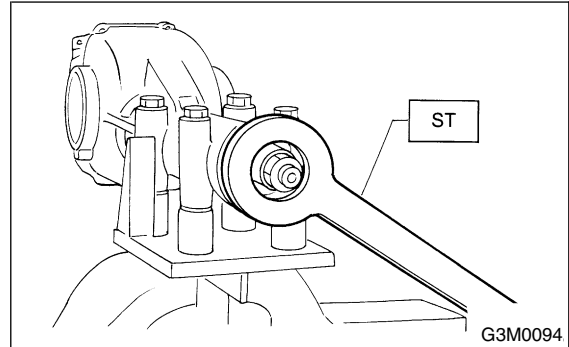

(2) Screw in side (left-side) holder until light contact is made with ST.

ST 399780111 WRENCH

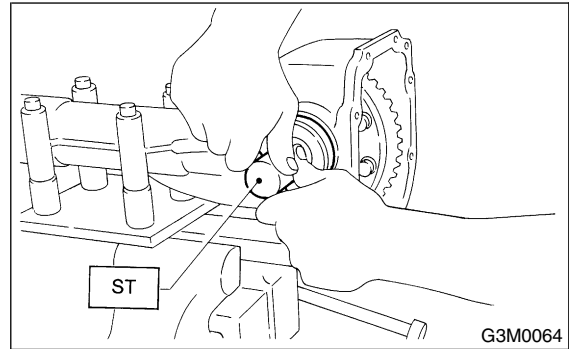

(3) Back off side (left-side) holder approximately 1 1/2 teeth of holder, and tighten left-side holder by approximately 2 teeth (approximately 1 1/2 + 1/2 teeth).

[Back off amount of side (left-side) holder + 1/2 tooth.]

This + 1/2 tooth gives preload.

(4) Temporarily tighten lock plate.

**NOTE:**

Turn over lock plate to displace holder 1/2 tooth.

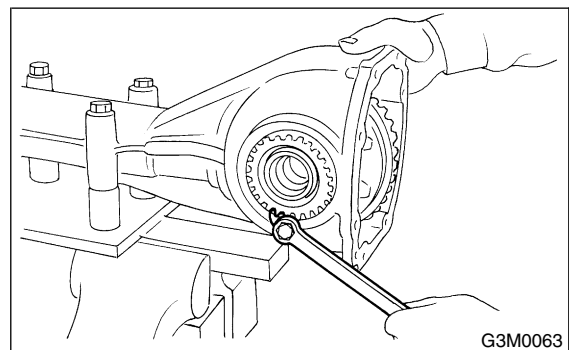

# REAR DIFFERENTIAL FOR VA-TYPE

## Differentials

(5) Measure the crown gear-to-drive pinion backlash. Set magnet base on differential carrier. Align contact point of dial gauge with tooth face of crown gear, and move crown gear while holding drive pinion still. Read value indicated on dial gauge.

### NOTE:

If measured backlash is not within specified range, repeat procedures for pinion crown gear set backlash adjustment and differential side bearing preload adjustment.

### Backlash:

**0.10 — 0.15 mm (0.0039 — 0.0059 in)**

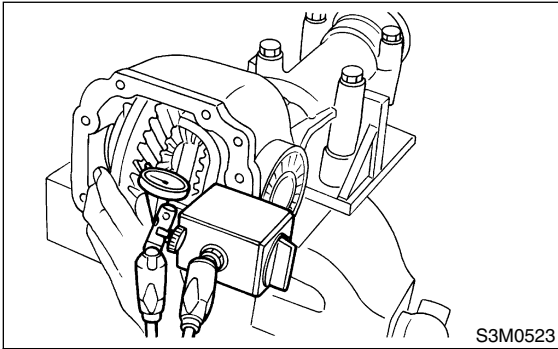

15) Draw a matching mark on both differential carrier and holder. Remove holder one side at a time. Replace in the original position after inserting an O-ring and applying grease to threaded portion.

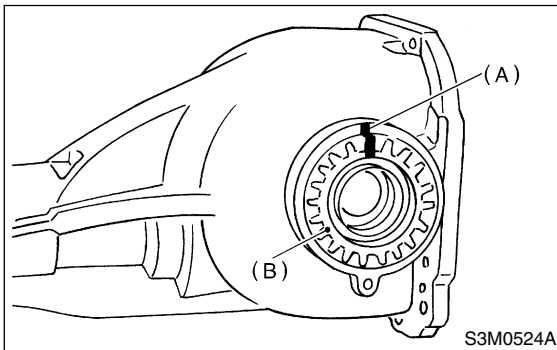

- (A) Matching mark
- (B) Holder

16) Tighten bolt of lock plate to specified torque.

### Tightening torque:

**25 N·m (2.5 kgf·m, 18.1 ft·lb)**

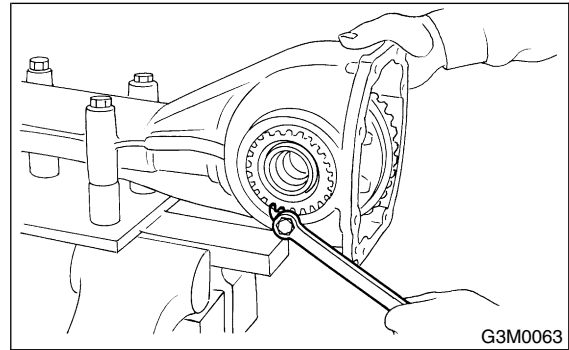

17) Re-check crown gear-to-pinion backlash.

### Backlash:

**0.10 — 0.15 mm (0.0039 — 0.0059 in)**

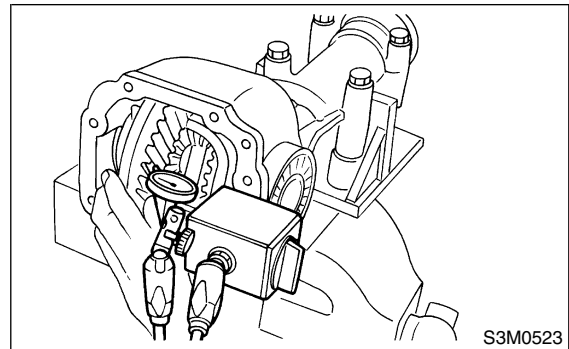

18) Check the crown gear runout on its back surface, and make sure pinion and crown gear rotate smoothly.

### Limit of runout:

**0.05 mm (0.0020 in)**

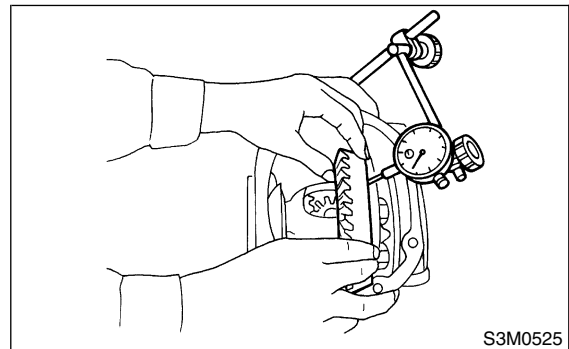

19) Checking and adjusting tooth contact of crown gear.

(1) Apply an even coat of red lead on both sides of three or four teeth on the crown gear. Check the contact pattern after rotating crown gear several revolutions back and forth until a definite contact pattern appears on the crown gear.

(2) When the contact pattern is incorrect, readjust according to the instructions given in "TOOTH CONTACT PATTERN".

**NOTE:**

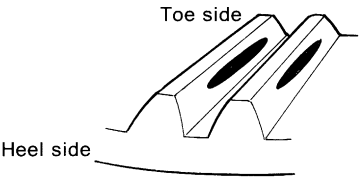
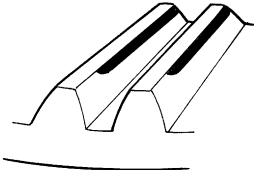
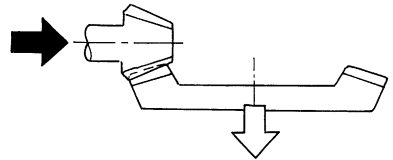
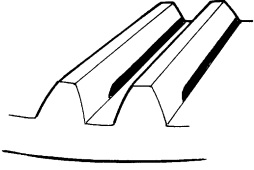
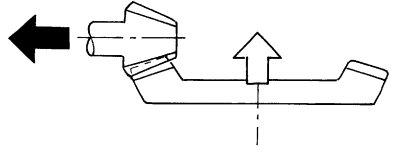
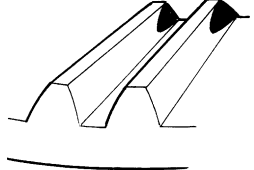
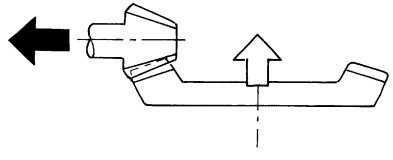

Be sure to wipe off red lead completely after adjustment is completed.

TOOTH CONTACT PATTERN		
Condition	Contact pattern	Adjustment
<p>Correct tooth contact Tooth contact pattern slightly shifted towards toe under no load rotation. (When loaded, contact pattern moves toward heel.)</p>	 <p style="text-align: right;">G3M0098A</p>	<p style="text-align: center;">—</p>
<p>Face contact Backlash is too large.</p>	 <p style="text-align: right;">G3M0098B</p>	<p>Increase thickness of drive pinion height adjusting washer in order to bring drive pinion closer to crown gear center.</p>  <p style="text-align: right;">G3M0098F</p>
<p>Flank contact Backlash is too small.</p>	 <p style="text-align: right;">G3M0098C</p>	<p>Reduce thickness of drive pinion height adjusting washer in order to move drive pinion away from crown gear.</p>  <p style="text-align: right;">G3M0098G</p>
<p>Toe contact</p>	<p>Contact area is small. This may cause chipping at toe ends.</p>  <p style="text-align: right;">G3M0098D</p>	<p>Adjust as for flank contact.</p>  <p style="text-align: right;">G3M0098G</p>

# REAR DIFFERENTIAL FOR VA-TYPE

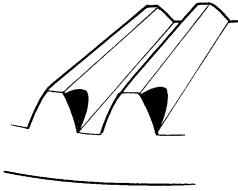
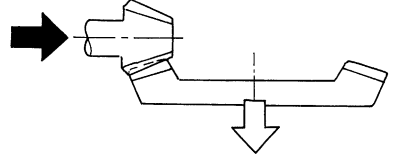
Differentials

TOOTH CONTACT PATTERN		
Condition	Contact pattern	Adjustment
Heel contact	Contact area is small. This may cause chipping at heel ends.  G3M0098E	Adjust as for face contact.  G3M0098F

 : Adjusting direction of drive pinion  
 : Adjusting direction of crown gear

20) If proper tooth contact is not obtained, once again adjust the drive pinion height and the differential side bearing preload (already mentioned) and the hypoid gear backlash.

(1) Drive pinion height

ST1 498447150 DUMMY SHAFT  
ST2 498505501 DIFFERENTIAL GAUGE

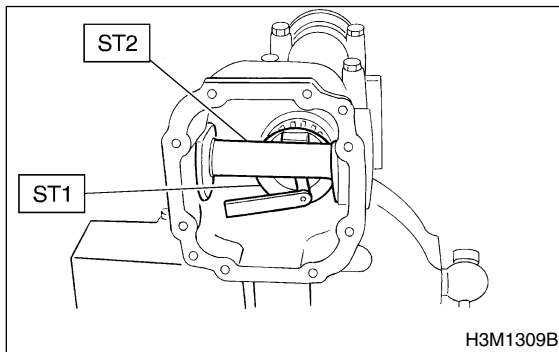

$$T = T_o + N - 0.05 \text{ (mm)}$$

where

T = Thickness of pinion height adjusting shim (mm)

$T_o$  = Thickness of shim originally installed (mm)

N = Reading of thickness gauge (mm)

(2) Differential side bearing preload  
Screw in side (left-side) holder until light contact is made with ST.

Back off side (left-side) holder approximately 1 1/2 teeth of holder, and tighten left-side holder by approximately 2 teeth (approximately 1 1/2 + 1/2 teeth).

[Back off amount of side (left-side) holder + 1/2 tooth.]

This + 1/2 tooth gives preload.

ST 399780111 WRENCH

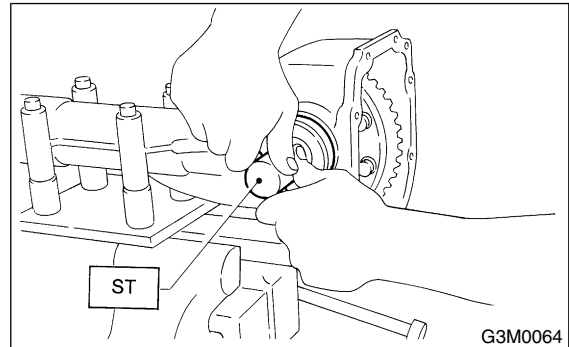

(3) Hypoid gear backlash

**Backlash:**

**0.10 — 0.15 mm (0.0039 — 0.0059 in)**

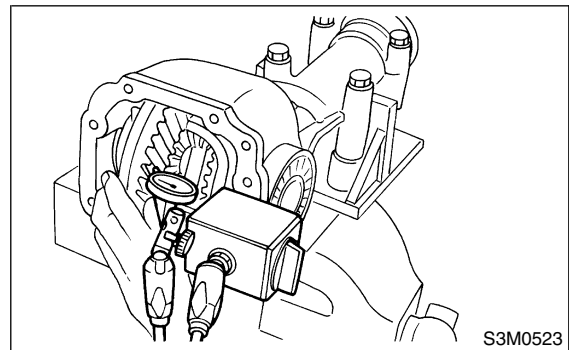



21) Install rear cover and tighten bolts to specified torque.

**Tightening torque:**

**25 N·m (2.5 kgf·m, 18.1 ft·lb)**

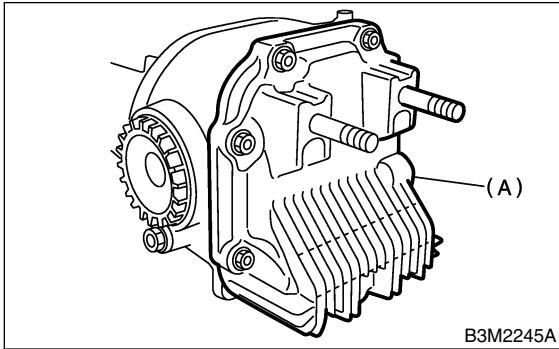

(A) Rear cover

**E: INSPECTION** S303151A10

Wash all the disassembled parts clean, and examine them for wear, damage, or other defects. Repair or replace defective parts as necessary.

1) Crown gear and drive pinion

- If abnormal tooth contact is evident, find out the cause and adjust to give correct tooth contact at assembly. Replace the gear if excessively worn or incapable of adjustment.

- If crack, score, or seizure is evident, replace as a set. Slight damage of tooth can be corrected by oil stone or the like.

2) Side gear and pinion mate gear

- Replace if crack, score, or other defects are evident on tooth surface.

- Replace if thrust washer contacting surface is worn or seized. Slight damage of the surface can be corrected by oil stone or the like.

3) Bearing

Replace if seizure, peeling, wear, rust, dragging during rotation, abnormal noise or other defect is evident.

4) Thrust washers of side gear and pinion mate gear

Replace if seizure, flaw, abnormal wear or other defect is evident.

5) Oil seal

Replace if deformed or damaged, and at every disassembling.

6) Differential carrier

Replace if the bearing bores are worn or damaged.

7) Differential case

Replace if its sliding surfaces are worn or cracked.

8) Companion flange

Replace if the oil seal lip contacting surfaces have flaws.

**1. SIDE GEAR BACKLASH** S303151A1001

Using a dial gauge, check the backlash of the side gear.

**Side gear backlash:**

**0.05 — 0.15 mm (0.0020 — 0.0059 in)**

If side gear backlash is not within the specification, adjust clearance as specified by selecting side gear thrust washer.

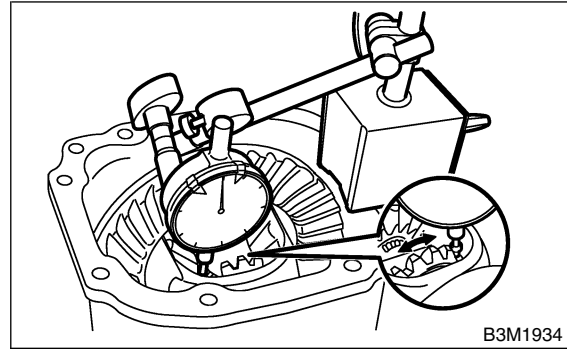

**2. CROWN GEAR BACKLASH** S303151A1002

Using a dial gauge, check the backlash of the crown gear.

**Crown gear backlash:**

**0.10 — 0.15 mm (0.0039 — 0.0059 in)**

If crown gear backlash is not within the specification, adjust the side bearing preload or repair if necessary.

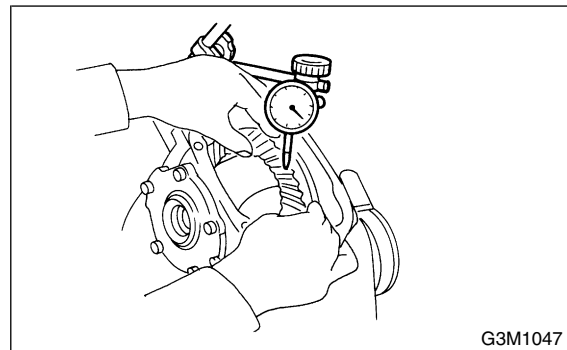

# REAR DIFFERENTIAL FOR VA-TYPE

Differentials

## 3. CROWN GEAR RUNOUT S303151A1003

Using a dial gauge, check the crown gear runout.

**Crown gear runout:**

**Less than 0.05 mm (0.0020 in)**

If the crown gear runout exceeds 0.05 mm (0.0020 in), replace the crown gear.

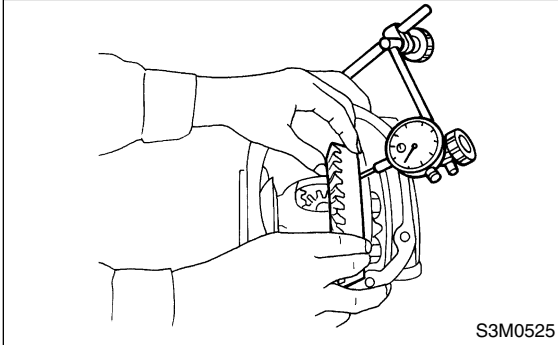

## 4. TOOTH CONTACT BETWEEN CROWN GEAR AND DRIVE PINION S303151A1004

Inspect tooth contact between crown gear and drive pinion.

<Ref. to DI-50, ASSEMBLY, Rear Differential for VA-type.>

## F: ADJUSTMENT S303151A01

### 1. SIDE GEAR BACKLASH A303151A0101

Adjust side gear backlash.

<Ref. to DI-50, ASSEMBLY, Rear Differential for VA-type.>

### 2. CROWN GEAR BACKLASH A303151A0102

Adjust crown gear backlash.

<Ref. to DI-50, ASSEMBLY, Rear Differential for VA-type.>

### 3. TOOTH CONTACT BETWEEN CROWN GEAR AND DRIVE PINION A303151A0103

Adjust the tooth contact between crown gear and drive pinion gear.

<Ref. to DI-50, ASSEMBLY, Rear Differential for VA-type.>