

5. Water Pump S176061

A: REMOVAL S176061A18

- 1) Disconnect ground cable from battery.

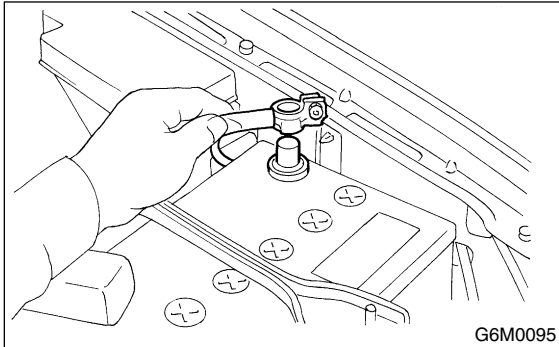

- 2) Lift-up the vehicle.
- 3) Remove under cover.

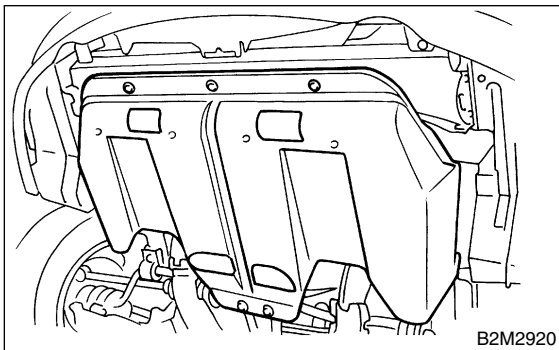

- 4) Drain engine coolant completely.
<Ref. to CO-12, DRAINING OF ENGINE COOLANT, REPLACEMENT, Engine Coolant.>
- 5) Disconnect connectors from radiator main fan (A) and sub fan (B) motors.

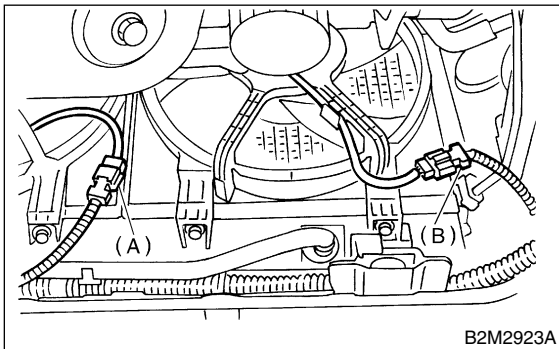

- 6) Disconnect radiator outlet hose and heater hose from water pump.

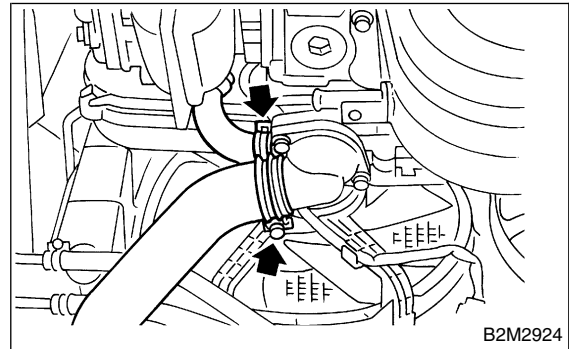

- 7) Lower the vehicle.
- 8) Remove air intake duct.

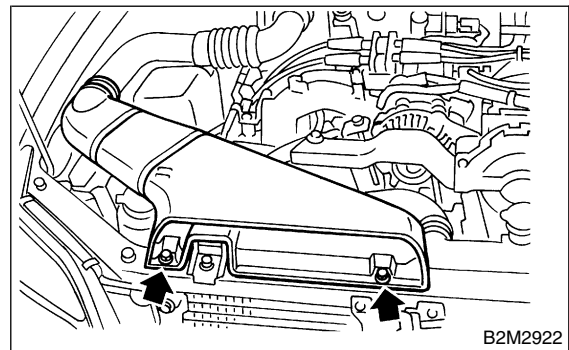

- 9) Disconnect overflow hose.

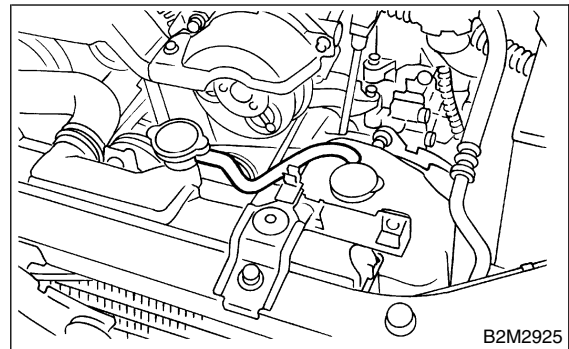

- 10) Remove reservoir tank.

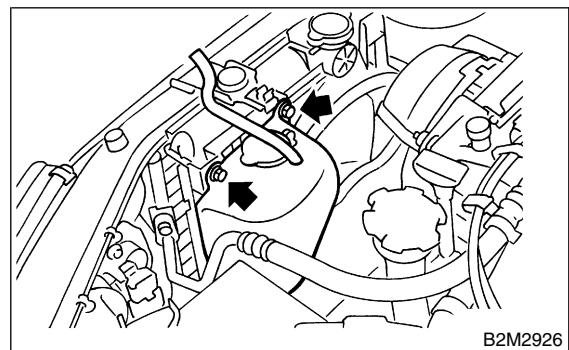

- 11) Remove radiator main fan and sub fan assemblies. <Ref. to CO-26, REMOVAL, Radiator Main Fan and Fan Motor.> and <Ref. to CO-29, REMOVAL, Radiator Sub Fan and Fan Motor.>

- 12) Remove V-belts.
<Ref. to ME-42, REMOVAL, V-belt.>
- 13) Remove timing belt.
<Ref. to ME-47, TIMING BELT, REMOVAL, Timing Belt Assembly.>
- 14) Remove automatic belt tension adjuster.

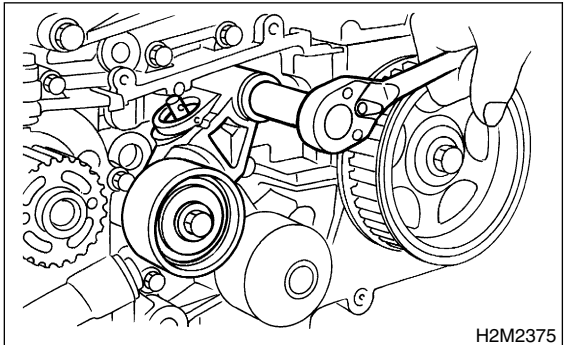

- 15) Remove belt idler No. 2.

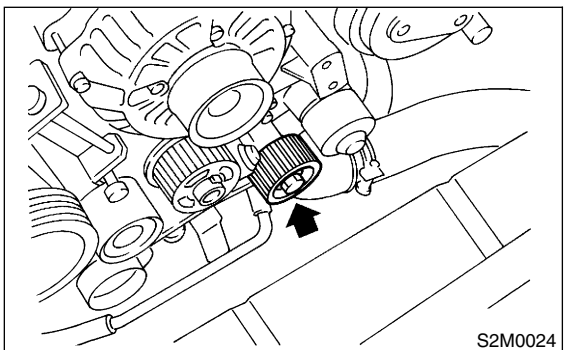

- 16) Remove left-hand camshaft sprocket by using ST.
ST 499207100 CAMSHAFT SPROCKET WRENCH

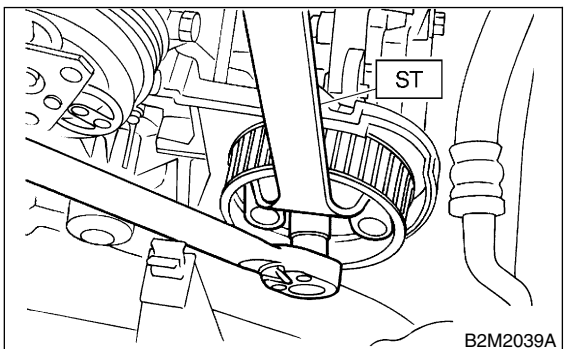

- 17) Remove tensioner bracket.

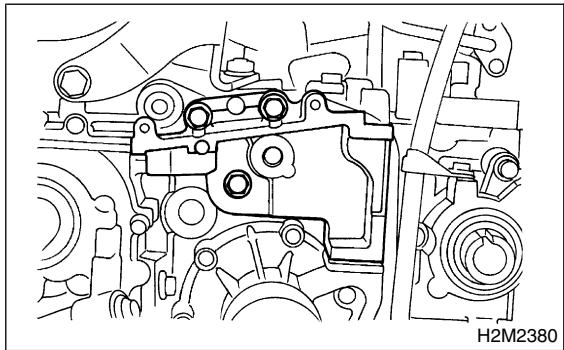

- 18) Remove left-hand belt cover No. 2.

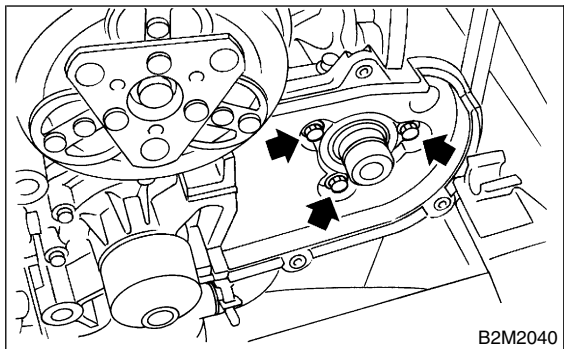

- 19) Disconnect heater hose from water pump.
- 20) Remove water pump.

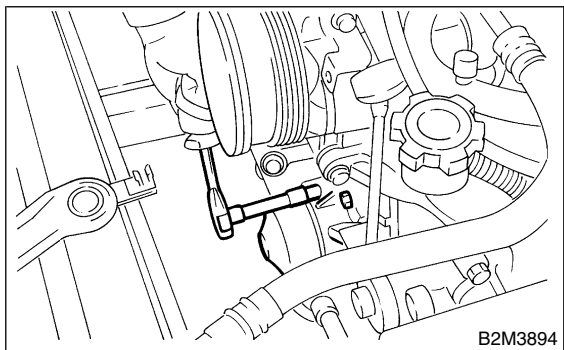

B: INSTALLATION S176061A11

1) Install water pump onto left-hand cylinder head.

CAUTION:

- Replace gasket with a new one.
- When installing water pump, tighten bolts in two stages in alphabetical sequence as shown in figure.

Tightening torque:

First:

12 N·m (1.2 kgf·m, 8.7 ft·lb)

Second:

12 N·m (1.2 kgf·m, 8.7 ft·lb)

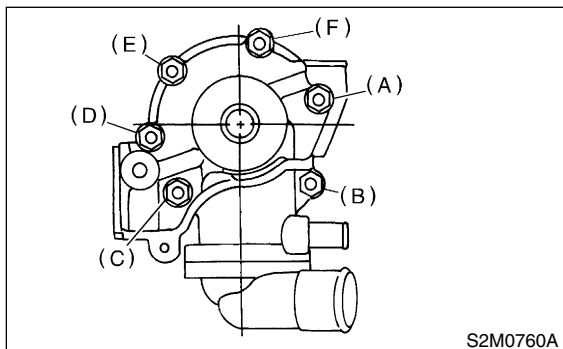

2) Install tensioner bracket.

Tightening torque:

25 N·m (2.5 kgf·m, 18.1 ft·lb)

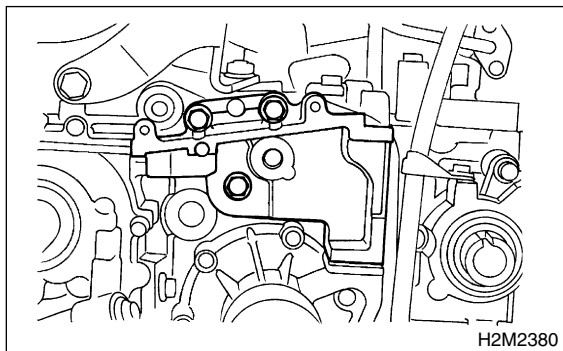

3) Install left-hand belt cover No. 2.

Tightening torque:

5 N·m (0.5 kgf·m, 3.6 ft·lb)

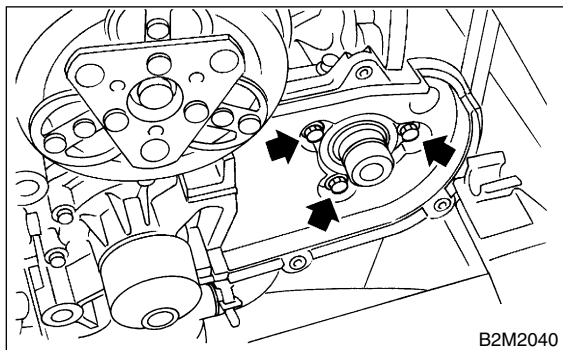

4) Install left-hand camshaft sprockets by using ST.

ST 4992707100 CAMSHAFT SPROCKET WRENCH

Tightening torque:

78 N·m (8.0 kgf·m, 57.9 ft·lb)

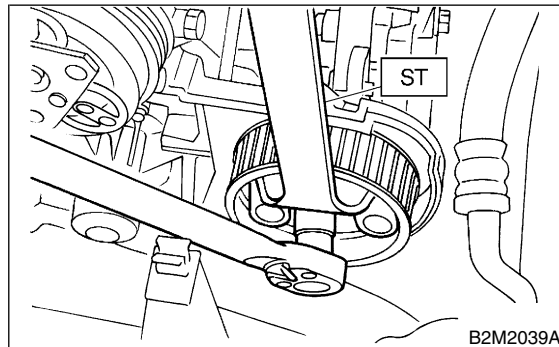

5) Install belt idler No. 2.

Tightening torque:

39 N·m (4.0 kgf·m, 28.9 ft·lb)

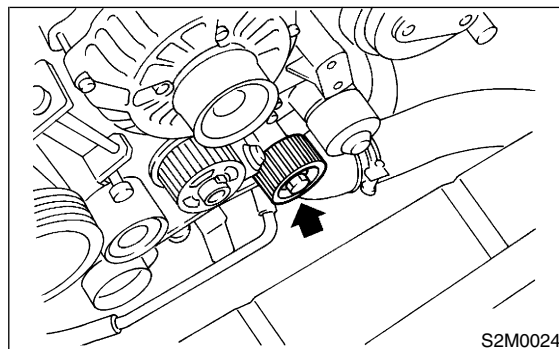

6) Install automatic belt tension adjuster which tension rod is held with pin. <Ref. to ME-48, AUTOMATIC BELT TENSION ADJUSTER ASSEMBLY AND BELT IDLER, INSTALLATION, Timing Belt Assembly.>

7) Install timing belt. <Ref. to ME-48, TIMING BELT, INSTALLATION, Timing Belt Assembly.>

8) Install V-belts. <Ref. to ME-42, INSTALLATION, V-belt.>

9) Install radiator main fan and sub fan motor assemblies. <Ref. to CO-27, INSTALLATION, Radiator Main Fan and Fan Motor.> and <Ref. to CO-29, INSTALLATION, Radiator Sub Fan and Fan Motor.>

10) Install reservoir tank.

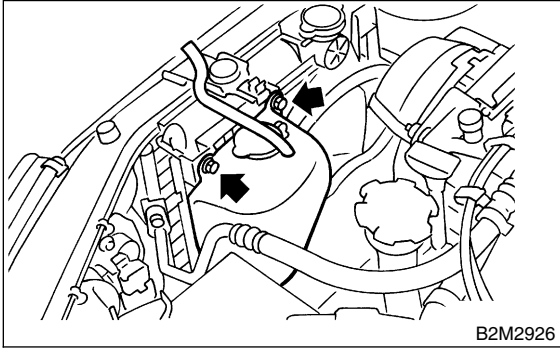

11) Connect overflow hose.

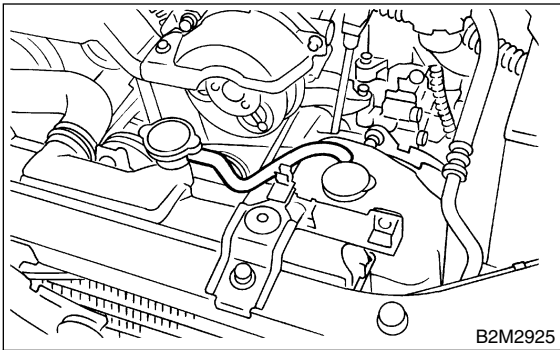

12) Install air intake duct.

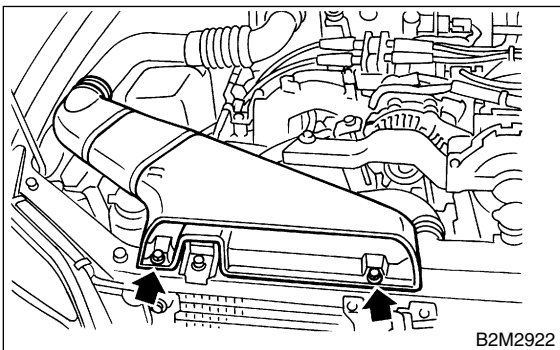

13) Lift-up the vehicle.

14) Connect radiator outlet hose and heater hose to water pump.

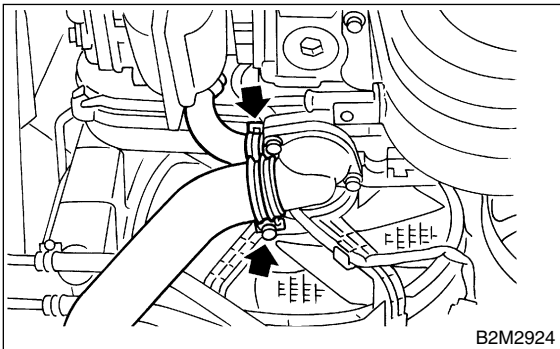

15) Connect connectors to radiator main fan (A) and sub fan (B) motors.

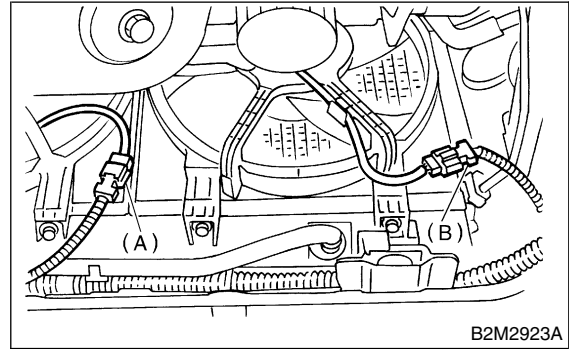

16) Install under cover.

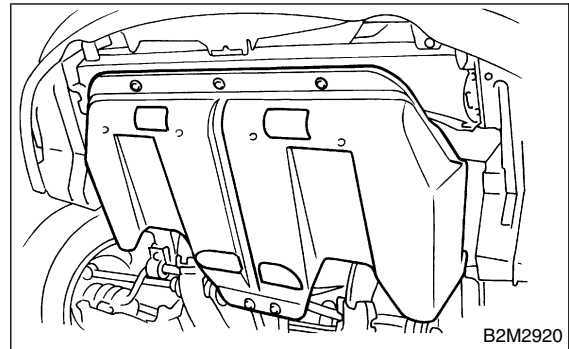

17) Lower the vehicle.

18) Connect battery ground cable.

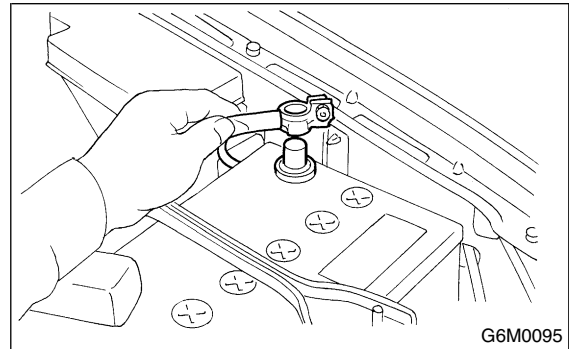

19) Fill coolant. <Ref. to CO-12, FILLING OF ENGINE COOLANT, REPLACEMENT, Engine Coolant.>

C: INSPECTION S176061A10

- 1) Check water pump bearing for smooth rotation.
- 2) Check water pump pulley for abnormalities.
- 3) Using a dial gauge, measure impeller runout in thrust direction while rotating the pulley.

“Thrust” runout limit:
0.5 mm (0.020 in)

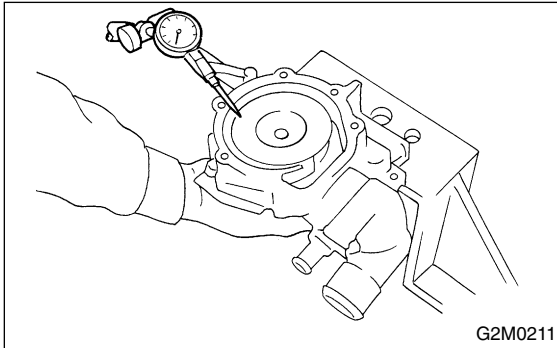

- 4) Check clearance between impeller and pump case.

Clearance between impeller and pump case:
Standard
0.5 — 0.7 mm (0.020 — 0.028 in)
Limit
1.0 mm (0.039 in)

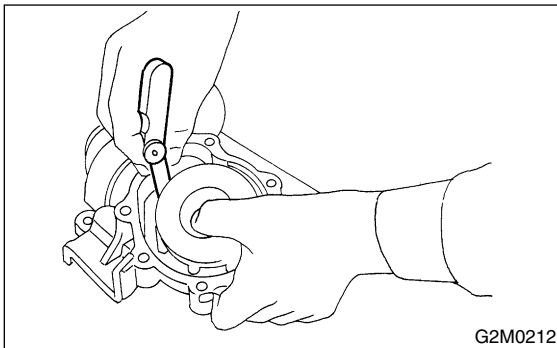

- 5) After water pump installation, check pulley shaft for engine coolant leaks. If leaks are noted, replace water pump assembly.