

10. Subaru Select Monitor S078503

A: OPERATION S078503A16

1. HOW TO USE SUBARU SELECT MONITOR S078503A1601

1) Prepare Subaru Select Monitor kit. <Ref. to EN-8, PREPARATION TOOL, General Description.>

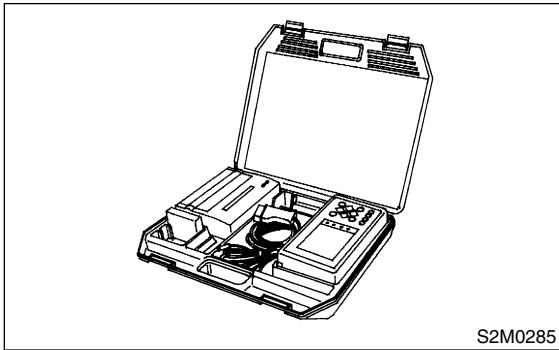

2) Connect diagnosis cable to Subaru Select Monitor.

3) Insert cartridge into Subaru Select Monitor. <Ref. to EN-8, PREPARATION TOOL, General Description.>

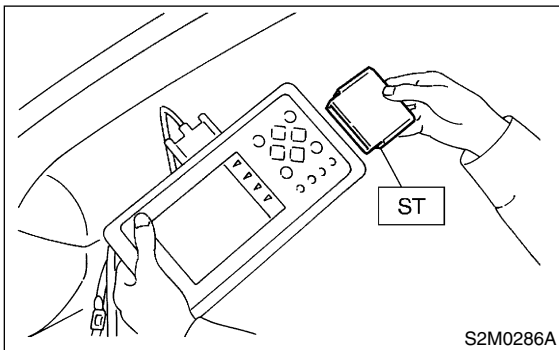

4) Connect Subaru Select Monitor to data link connector.

(1) Data link connector (A) located in the lower portion of the instrument panel (on the driver's side).

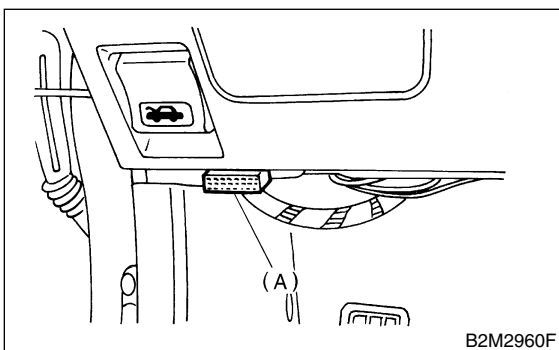

(2) Connect diagnosis cable to data link connector.

CAUTION:

Do not connect scan tools except for Subaru Select Monitor and OBD-II general scan tool.

5) Turn ignition switch to ON (engine OFF) and Subaru Select Monitor switch to ON.

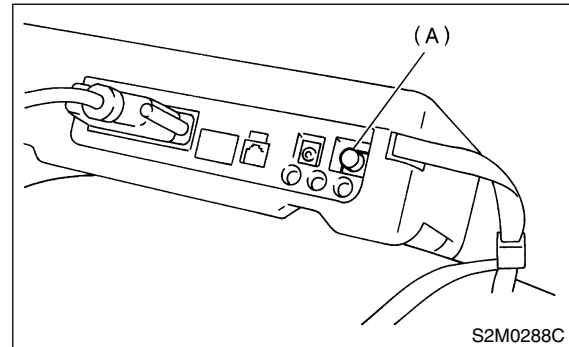

(A) Power switch

6) Using Subaru Select Monitor, call up diagnostic trouble code(s) and various data, then record them.

2. READ DIAGNOSTIC TROUBLE CODE (DTC) FOR ENGINE. (NORMAL MODE)

S078503A1610

Refer to Read Diagnostic Trouble Code for information about how to indicate DTC. <Ref. to EN-47, Read Diagnostic Trouble Code.>

3. READ DIAGNOSTIC TROUBLE CODE (DTC) FOR ENGINE. (OBD MODE) S078503A1611

Refer to Read Diagnostic Trouble Code for information about how to indicate DTC. <Ref. to EN-47, Read Diagnostic Trouble Code.>

4. READ CURRENT DATA FOR ENGINE. (NORMAL MODE) S078503A1604

- 1) On the «Main Menu» display screen, select the {Each System Check} and press the [YES] key.
 - 2) On the «System Selection Menu» display screen, select the {Engine Control System} and press the [YES] key.
 - 3) Press the [YES] key after displayed the information of engine type.
 - 4) On the «Engine Diagnosis» display screen, select the {Current Data Display & Save} and press the [YES] key.
 - 5) On the «Data Display Menu» display screen, select the {Data Display} and press the [YES] key.
 - 6) Using the scroll key, move the display screen up or down until the desired data is shown.
- A list of the support data is shown in the following table.

Contents	Display	Unit of measure
Battery voltage	Battery Voltage	V
Vehicle speed signal	Vehicle Speed	km/h or MPH
Engine speed signal	Engine Speed	rpm
Engine coolant temperature signal	Coolant Temp.	°C or °F
Ignition timing signal	Ignition Timing	deg
Throttle position signal	Throttle Opening Angle	%
Throttle position signal	Throttle Sensor Voltage	V
Injection pulse width	Fuel Injection #1 Pulse	ms
Idle air control signal	ISC Valve Step	STEP
Engine load data	Engine Load	%
Front oxygen (A/F) sensor output signal	A/F Sensor #1	—
Rear oxygen sensor output signal	Rear O2 Sensor	V
Short term fuel trim	A/F Correction #1	%
Knock sensor signal	Knocking Correction	deg
Atmospheric absolute pressure signal	Atmosphere Pressure	mmHg or kPa or inHg or psig
Intake manifold relative pressure signal	Mani. Relative Pressure	mmHg or kPa or inHg or psig
Intake manifold absolute pressure signal	Mani. Absolute Pressure	mmHg or kPa or inHg or psig
A/F correction (short term fuel trim) by rear oxygen sensor	A/F Correction #3	%
Long term whole fuel trim	A/F Learning #1	%
Front oxygen (A/F) sensor heater current	Front O2 Heater #1	A
Rear oxygen sensor heater voltage	Rear O2 Heater Voltage	V
Canister purge control solenoid valve duty ratio	CPC Valve Duty Ratio	%
Fuel tank pressure signal	Fuel Tank Pressure	mmHg or kPa or inHg or psig
Fuel temperature signal	Fuel Temp.	°C or °F
Fuel level signal	Fuel Level	V
Intake air temperature signal	Intake Air Temp.	°C or °F
Learned ignition timing	Learned Ignition Timing	V
Ignition switch signal	Ignition Switch	ON or OFF
Test mode connector signal	Test Mode Signal	ON or OFF
Neutral position switch signal	Neutral Position Switch	ON or OFF
Air conditioning switch signal	A/C Switch	ON or OFF
Air conditioning compressor signal	A/C Compressor Signal	ON or OFF
Radiator main fan relay signal	Radiator Fan Relay #1	ON or OFF
Fuel pump relay signal	Fuel Pump Relay	ON or OFF
Knocking signal	Knocking Signal	ON or OFF
Radiator sub fan relay signal	Radiator Fan Relay #2	ON or OFF
Engine torque control signal #1	Torque Control Signal #1	ON or OFF
Engine torque control signal #2	Torque Control Signal #2	ON or OFF

SUBARU SELECT MONITOR

Engine (Diagnostics)

Contents	Display	Unit of measure
Engine torque control permission signal	Torque Permission Signal	ON or OFF
Rear oxygen sensor rich signal	Rear O2 Rich Signal	ON or OFF
Pressure control solenoid valve	PCV Solenoid Valve	ON or OFF
Drain valve	Vent. Solenoid Valve	ON or OFF
Starter switch signal	Starter Switch	ON or OFF
Idle switch signal	Idle Switch Signal	ON or OFF
Crankshaft position sensor signal	Crankshaft Position Sig.	ON or OFF
Camshaft position sensor signal	Camshaft Position Sig.	ON or OFF
Rear defogger switch signal	Rear Defogger Switch	ON or OFF
Blower fan switch signal	Blower Fan Switch	ON or OFF
Small light switch signal	Light Switch	ON or OFF
Air assist injector solenoid valve signal	Assist Air Sol. Valve	ON or OFF
Power steering switch signal	P/S Switch	ON or OFF

NOTE:

- For detailed operation procedure, refer to the SUBARU SELECT MONITOR OPERATION MANUAL.
- For select monitor display details, refer to the following.

Engine Load

Display: 0 — 100 %

The engine load is displayed. The ECM calculates the engine load via the engine speed and signals from the pressure sensor. The engine load increases when the engine speed and absolute pressure of the intake manifold increase.

Coolant Temp.

Display: -40 to 215°C (-40 to 419°F)

The coolant temperature transmitted from the engine coolant temperature sensor is displayed.

A/F Correction #1

Display: -100 to 99 %

Using the signal from the front oxygen (A/F) sensor, the correction value of the fuel supply amount regulated by the ECM is indicated. When the A/F is lean and when displayed value becomes 0 % or more, ECM increases the fuel. When the A/F is rich and when displayed value becomes 0 % or less, ECM decreases the fuel.

A/F Learning #1

Display: -100 to 99.2 %

The ECM calculates the long-term fuel trim value from the short-term fuel trim value. The long-term fuel trim value means the correction value of long-term fuel supply amount. If the displayed value is less than 0 %, the fuel system is in rich status and the ECM restricts the fuel supply (by shortening the injector pulse). If the displayed value is more than 0 %, the fuel system is in lean status and the ECM increases the fuel supply (by extending the injector pulse).

Mani Absolute Pressure

Display: 0 — 254.9 kPa (0 — 1,912.5 mmHg, 0 — 75.3 inHg)

The pressure in the intake manifold is displayed. The ECM detects the pressure in the intake tube via the signal from the pressure sensor. The ECM calculates the air mass required for the engine.

Engine Speed

Display: 0 — 16,383 rpm

The engine speed transmitted from the crankshaft position sensor is detected.

Vehicle Speed

Display: 0 — 255 km/h (0 — 158 MPH)

The vehicle speed transmitted from the vehicle speed sensor is displayed.

Ignition Timing

Display: -64 to 63.5 deg.

The advanced ignition timing value is displayed. The ECM calculates the advanced ignition timing value using engine coolant temperature, engine speed, and engine load.

Intake Air Temp.

Display: 40 — 215°C (104 — 419°F)

The intake air temperature is displayed. The ECM detects the intake air temperature via the signal from the intake air temperature sensor, and corrects the ignition timing and fuel supply amount.

Rear O2 sensor

Display: 0 — 327.7 Volt

The ECM correct air-fuel ratio by the signal sent from O2 sensor. Also, the signal is used for catalyst degradation diagnosis.

Battery Voltage**Display: 0 — 20.4 V**

The battery voltage is displayed.

Throttle Sensor Voltage**Display: 0 — 5 V**

The throttle angle is displayed in voltage. When the throttle is fully-closed, the displayed voltage value is approx. 0.5 V. When it is fully-open, the voltage is approx. 4 V or more.

Fuel injection #1 Pulse**Display: 0 — 65.3 m/sec (0 — 214.2 ft/sec)**

The injector valve opening time is displayed. The longer the injector valve opening time, the more the fuel is supplied. The higher the engine load, the longer the injector valve opening time becomes.

Knocking Correction**Display: -64 to 63.5 deg.**

The ECM controls the ignition timing via the signal from the knock sensor.

Atmosphere Pressure**Display: 0 — 254.9 kPa (0 — 1,912.5 mmHg, 0 — 75.3 inHg)**

The atmospheric pressure is displayed. The ECM detects the atmospheric pressure via the signal from the atmosphere sensor.

Mani. Relative Pressure**Display: 0 — 126.9 kPa (0 — 952 mmHg, 0 — 37.5 inHg)**

A value calculated by subtracting the absolute pressure in the intake tube from the atmospheric pressure is displayed. A larger load leads to a larger value.

Fuel tank pressure**Display: 0 — 3.2 kPa (0 — 24 mmHg, 0 — 0.94 inHg)**

The pressure in the fuel tank is displayed.

Learned Ignition Timing**Display: -64 to 63.5 deg.**

The advanced ignition timing value is displayed. The ECM calculates the learned ignition timing in each driving range via the signal from the knock sensor. A positive value indicates advanced timing, and a negative value indicates retarded timing.

Fuel Temp.**Display: -40 to 215°C (-40 to 419°F)**

The fuel temperature is displayed. The ECM detects the fuel temperature via the signal from the fuel temperature sensor. This signal is used for the evaporation diagnosis.

Front O2 Heater #1**Display: 0 — 10A**

The heater current of the front oxygen (A/F) sensor is displayed. A larger current value leads to increased heat generation.

Rear O2 Heater Current**Display: 0 — 10 A**

The heater current of the rear O2 sensor is displayed. A larger current value leads to increased heat generation.

Fuel Level**Display: 0 — 5 V**

The float inside the fuel tank is a variable resistor which varies the resistance based on fuel level. The ECM then averages this voltage and the signal voltage from the fuel tank in order to determine fuel level. The scan tool displays close to 0.7 volts for an empty tank, and close to 5 volts for a full tank.

CPC Valve Duty Ratio**Display: 0 — 100 %**

The purge control solenoid valve is regulated by the ECM. The displayed value of 0 % indicates that the purge amount is 0, and 100 % indicates that the purge amount becomes the maximum.

ISC Valve Step**Display: 0 — 255 step**

The idle air control solenoid valve is driven by the stepping motor. The number of steps is regulated by the ECM. A value of 0 step indicates that the air bypass circuit is closed, and the value of 255 steps indicates that it is fully open.

A/F Sensor #1**Display: 0 — 2**

The air surplus ratio output from the front oxygen (A/F) sensor is displayed. Air overflow ratio = 1.0 is regarded as a stoichiometric A/F ratio. A value above 1.0 indicates A/F lean range, and below 1.0 indicates A/F rich range.

A/F Correction #3**Display:**

The correction value of fuel supply amount regulated by the ECM via the signal from the rear oxygen sensor is displayed.

AT Vehicle ID Signal**Display: ON or OFF**

AT and MT vehicles are identified. For AT vehicles, ON is displayed, and for MT ones, OFF is displayed.

SUBARU SELECT MONITOR

Engine (Diagnostics)

Neutral Position Switch **Display: ON or OFF**

When the shift lever stays in the neutral position, ON is displayed. When in other positions, OFF is displayed.

Idle Switch Signal **Display: ON or OFF**

When the accelerator pedal is released fully, ON is displayed. When depressed fully, OFF is displayed.

P/S Switch **Display: ON or OFF**

When the steering wheel is turned fully, ON is displayed. When returned, OFF is displayed. This signal is used for idle control or other controls.

A/C Switch **Display: ON or OFF**

When the A/C switch is turned ON, ON is displayed. When turned OFF, OFF is displayed. This signal is used for idle control or other controls.

Starter Switch **Display: ON or OFF**

When the vehicle is cranking, ON is displayed. When not cranking, OFF is displayed.

Rear O2 Rich Signal **Display: ON or OFF**

When the A/F ratio is rich, ON is displayed. When lean, OFF is displayed.

Knocking Signal **Display: ON or OFF**

When knocking occurs and the ignition timing is retarded, ON is displayed. At any other time, OFF is displayed.

Crankshaft Position Sig. **Display: ON or OFF**

When a crankshaft signal exists, ON is displayed. At any other time (at engine stall), OFF is displayed.

Camshaft Position Sig. **Display: ON or OFF**

When a camshaft signal exists, ON is displayed. At any other time (at engine stall), OFF is displayed.

Rear Defogger SW **Display: ON or OFF**

When the rear defogger switch is turned ON, ON is displayed. When turned OFF, OFF is displayed. This signal is used for idle control or other controls.

Blower Fan SW **Display: ON or OFF**

When the blower fan switch is turned ON, ON is displayed. When turned OFF, OFF is displayed. This signal is used for idle control or other controls.

Light Switch **Display: ON or OFF**

When the light switch is turned ON, ON is displayed. When turned OFF, OFF is displayed. This signal is used for idle control or other controls.

A/C Compressor Signal **Display: ON or OFF**

When the A/C clutch is engaged, ON is displayed. When disengaged, OFF is displayed.

Radiator Fan Relay #1, #2 **Display: ON or OFF**

When the radiator fan relay is ON (radiator operates), ON is displayed. When OFF (radiator stops), OFF is displayed.

Fuel Pump Relay **Display: ON or OFF**

When the radiator fan relay is ON (fuel pump operates), ON is displayed. When OFF (fuel pump stops), OFF is displayed.

PCV Solenoid Valve **Display: ON or OFF**

The status of the pressure control solenoid valve is displayed. When the pressure control solenoid valve is closed, OFF is displayed. When open, ON is displayed. During an evaporation leak diagnosis, the pressure control solenoid valve is only open when vacuum in the intake tube is taken into the fuel tank.

Vent Solenoid Valve **Display: ON or OFF**

The status of the drain valve is displayed. When the drain valve is closed, ON is displayed. When open, OFF is displayed. Except during an evaporation leak diagnosis, the drain valve is always open.

Assist Air Sol. Valve **Display: ON or OFF**

When the air assist injector solenoid valve is open, ON is displayed. When closed, OFF is displayed. The air assist injector solenoid valve opens to increase mass air flow at cold start, improving the mixture formation.

Tank Sensor Cont. Valve**Display: ON or OFF**

When the atmospheric pressure solenoid valve is open, ON is displayed. When closed, OFF is displayed. The valve is only activated during a 0.02-inch evaporation leak diagnosis.

Torque Control Signal #1, #2**Display: ON or OFF**

When a torque down signal exists, ON is displayed. When it doesn't, OFF is displayed.

Torque Permission Signal**Display: ON or OFF**

The signal which notifies whether or not torque down is possible is displayed. This signal is transmitted from the ECU in response to a torque down signal from the TCU. When torque down is prohibited, ON is displayed. When permitted, OFF is displayed.

SUBARU SELECT MONITOR

Engine (Diagnostics)

5. READ CURRENT DATA FOR ENGINE. (OBD MODE) S078503A1605

- 1) On the «Main Menu» display screen, select the {Each System Check} and press the [YES] key.
 - 2) On the «System Selection Menu» display screen, select the {Engine Control System} and press the [YES] key.
 - 3) Press the [YES] key after displayed the information of engine type.
 - 4) On the «Engine Diagnosis» display screen, select the {OBD System} and press the [YES] key.
 - 5) On the «OBD Menu» display screen, select the {Current Data Display & Save} and press the [YES] key.
 - 6) On the «Data Display Menu» display screen, select the {Data Display} and press the [YES] key.
 - 7) Using the scroll key, move the display screen up or down until the desired data is shown.
- A list of the support data is shown in the following table.

Contents	Display	Unit of measure
Number of diagnosis code	Number of Diag. Code	—
Malfunction indicator lamp status	MI (MIL)	ON or OFF
Monitoring test of misfire	Misfire monitoring	Complete or incomplete
Monitoring test of fuel system	Fuel system monitoring	Complete or incomplete
Monitoring test of comprehensive component	Component monitoring	Complete or incomplete
Test of catalyst	Catalyst Diagnosis	Complete or incomplete
Test of heated catalyst	Heated catalyst	No support
Test of evaporative emission purge control system	Evaporative purge system	Complete or incomplete
Test of secondary air system	Secondary air system	No support
Test of air conditioning system refrigerant	A/C system refrigerant	No support
Test of oxygen sensor	Oxygen sensor	Complete or incomplete
Test of oxygen sensor heater	O2 Heater Diagnosis	Complete or incomplete
Air fuel ratio control system for bank 1	Fuel System for Bank 1	ON or OFF
Engine load data	Calculated load valve	—
Engine coolant temperature signal	Coolant Temp.	°C or °F
Short term fuel trim by front oxygen (A/F) sensor	Short term fuel trim B1	%
Long term fuel trim by front oxygen (A/F) sensor	Long term fuel trim B1	%
Intake manifold absolute pressure signal	Mani. Absolute Pressure	mmHg or kPa or inHg or psig
Engine speed signal	Engine Speed	rpm
Vehicle speed signal	Vehicle Speed	km/h or MPH
Ignition timing advance for #1 cylinder	Ignition timing adv. #1	°
Intake air temperature signal	Intake Air Temp.	°C or °F
Intake air amount signal	Mass Air Flow	g/s
EGR signal	EGR System	No support
Throttle position signal	Throttle Opening Angle	%
A/F sensor equipment	A/F sensor	ON or OFF
Rear oxygen sensor output signal	Oxygen Sensor #12	V
Air fuel ratio correction by rear oxygen sensor	Short term fuel trim #12	%
On-board diagnostic system	OBD System	—
Front oxygen (A/F) sensor equipment	Oxygen sensor #11	Supported
Oxygen sensor equipment	Oxygen sensor #12	Supported
Front oxygen (A/F) sensor output signal	A/F Sensor #11	V

NOTE:

For detailed operation procedure, refer to the SUBARU SELECT MONITOR OPERATION MANUAL.

6. READ FREEZE FRAME DATA FOR ENGINE. (OBD MODE) S078503A1606

- 1) On the «Main Menu» display screen, select the {Each System Check} and press the [YES] key.
- 2) On the «System Selection Menu» display screen, select the {Engine Control System} and press the [YES] key.
- 3) Press the [YES] key after displayed the information of engine type.
- 4) On the «Engine Diagnosis» display screen, select the {OBD System} and press the [YES] key.

5) On the «OBD Menu» display screen, select the {Freeze Frame Data} and press the [YES] key.

- A list of the support data is shown in the following table.

Contents	Display	Unit of measure
Diagnostic trouble code (DTC) for freeze frame data	Freeze frame data	DTC
Air fuel ratio control system for bank 1	Fuel system for Bank 1	ON or OFF
Engine load data	Engine Load	%
Engine coolant temperature signal	Coolant Temp.	°C or °F
Short term fuel trim by front oxygen (A/F) sensor	Short term fuel trim B1	%
Long term fuel trim by front oxygen (A/F) sensor	Long term fuel trim B1	%
Intake manifold absolute pressure signal	Mani. Absolute Pressure	mmHg or kPa or inHg or psig
Engine speed signal	Engine Speed	rpm
Vehicle speed signal	Vehicle Speed	km/h or MPH

NOTE:

For detailed operation procedure, refer to the SUBARU SELECT MONITOR OPERATION MANUAL.

7. READ OXYGEN SENSOR MONITORING TEST RESULTS DATA FOR ENGINE. (OBD MODE) S078503A1607

- 1) On the «Main Menu» display screen, select the {Each System Check} and press the [YES] key.
- 2) On the «System Selection Menu» display screen, select the {Engine Control System} and press the [YES] key.
- 3) Press the [YES] key after displayed the information of engine type.
- 4) On the «Engine Diagnosis» display screen, select the {OBD System} and press the [YES] key.
- 5) On the «OBD Menu» display screen, select the {O2 Sensor Monitor} and press the [YES] key.
- 6) On the «O2 Sensor Select» display screen, select the {Bank 1-Sensor1} or {Bank 1-Sensor2} and press the [YES] key.

- Bank 1-Sensor1 indicates the front oxygen or A/F sensor, and Bank 1-Sensor2 indicates the rear oxygen sensor.

- A list of the support data is shown in the following table.

Contents	Display	Unit of measure
Oxygen sensor for monitoring test	<O2 Sensor Monitor (-----)>	—
Rich to lean oxygen sensor threshold voltage	Rich to lean sensor volt	V
Lean to rich oxygen sensor threshold voltage	Lean to rich sensor volt	V
Low oxygen sensor voltage for switch time calculation	Low sensor voltage	V
High oxygen sensor voltage for switch time calculation	High sensor voltage	V
Rich to lean oxygen sensor switch time	Rich to lean switch time	sec
Lean to rich oxygen sensor switch time	Lean to rich switch time	sec
Maximum oxygen sensor voltage for test cycle	Maximum sensor Voltage	V
Minimum oxygen sensor voltage for test cycle	Minimum sensor Voltage	V

NOTE:

For detailed operation procedure, refer to the SUBARU SELECT MONITOR OPERATION MANUAL.

8. LED OPERATION MODE FOR ENGINE S078503A1608

- 1) On the «Main Menu» display screen, select the {Each System Check} and press the [YES] key.
- 2) On the «System Selection Menu» display screen, select the {Engine Control System} and press the [YES] key.
- 3) Press the [YES] key after displayed the information of engine type.
- 4) On the «Engine Diagnosis» display screen, select the {Current Data Display & Save} and press the [YES] key.
- 5) On the «Data Display Menu» display screen, select the {Data & LED Display} and press the [YES] key.
- 6) Using the scroll key, move the display screen up or down until the desired data is shown.

- A list of the support data is shown in the following table.

SUBARU SELECT MONITOR

Engine (Diagnostics)

Contents	Display	Message	LED "ON" requirements
Ignition switch signal	Ignition Switch	ON or OFF	When ignition switch is turned ON.
Test mode connector signal	Test Mode Signal	ON or OFF	When test mode connector is connected.
Neutral position switch signal	Neutral Position Switch	ON or OFF	When neutral position signal is entered.
Air conditioning switch signal	A/C Switch	ON or OFF	When air conditioning switch is turned ON.
Air conditioning relay signal	A/C Relay	ON or OFF	When air conditioning relay is in function.
Radiator main fan relay signal	Radiator Fan Relay #1	ON or OFF	When radiator main fan relay is in function.
Fuel pump relay signal	Fuel Pump Relay	ON or OFF	When fuel pump relay is in function.
Knocking signal	Knocking Signal	ON or OFF	When knocking signal is entered.
Radiator sub fan relay signal	Radiator Fan Relay #2	ON or OFF	When radiator sub fan relay is in function.
Engine torque control signal #1	Torque Control Signal #1	ON or OFF	When engine torque control signal 1 is entered.
Engine torque control signal #2	Torque Control Signal #2	ON or OFF	When engine torque control signal 2 is entered.
Engine torque control permission signal	Torque Control Permit	ON or OFF	When engine torque control permission signal is entered.
Front oxygen (A/F) sensor rich signal	Front O2 Rich Signal #1	ON or OFF	When front oxygen (A/F) sensor mixture ratio is rich.
Rear oxygen sensor rich signal	Rear O2 Rich Signal	ON or OFF	When rear oxygen sensor mixture ratio is rich.
Pressure control solenoid valve	PCV Solenoid Valve	ON or OFF	When pressure control solenoid valve is in function.
Drain valve	Vent. Solenoid Valve	ON or OFF	When drain valve is in function.
Starter switch signal	Starter Switch Signal	ON or OFF	When starter switch signal is entered.
Idle switch signal	Idle Switch Signal	ON or OFF	When idle switch signal is entered.
Crankshaft position sensor signal	Crankshaft Position Sig.	ON or OFF	When crankshaft position sensor signal is entered.
Camshaft position sensor signal	Camshaft Position Sig.	ON or OFF	When camshaft position sensor signal is entered.

NOTE:

For detailed operation procedure, refer to the SUBARU SELECT MONITOR OPERATION MANUAL.

9. READ CURRENT DATA FOR AT. S078503A1612

- 1) On the «Main Menu» display screen, select the {Each System Check} and press the [YES] key.
 - 2) On the «System Selection Menu» display screen, select the {Transmission Control System} and press the [YES] key.
 - 3) Press the [YES] key after displayed the information of transmission type.
 - 4) On the «Transmission Diagnosis» display screen, select the {Current Data Display & Save} and press the [YES] key.
 - 5) On the «Data Display Menu» display screen, select the {Data Display} and press the [YES] key.
 - 6) Using the scroll key, move the display screen up or down until the desired data is shown.
- A list of the support data is shown in the following table.

SUBARU SELECT MONITOR

Engine (Diagnostics)

Contents	Display	Unit of measure
Battery voltage	Battery Voltage	V
Rear vehicle speed sensor signal	Vehicle Speed #1	km/h or MPH
Front vehicle speed sensor signal	Vehicle Speed #2	km/h or MPH
Engine speed signal	Engine Speed	rpm
Automatic transmission fluid temperature signal	ATF Temp.	°C or °F
Throttle position signal	Throttle Sensor Voltage	V
Gear position	Gear Position	—
Line pressure control duty ratio	Line Pressure Duty Ratio	%
Lock up clutch control duty ratio	Lock Up Duty Ratio	%
Transfer clutch control duty ratio	Transfer Duty Ratio	%
Power supply for throttle position sensor	Throttle Sensor Power	V
Torque converter turbine speed signal	AT Turbine Speed	rpm
2-4 brake timing pressure control duty ratio	2-4B Duty Ratio	%
Intake manifold pressure sensor voltage	Mani. Pressure Voltage	V
2 wheel drive switch signal	2WD Switch	ON or OFF
Stop lamp switch signal	Stop Lamp Switch	ON or OFF
Anti lock brake system signal	ABS Signal	ON or OFF
Cruise control system signal	Cruise Control Signal	ON or OFF
Neutral/Parking range signal	N/P Range Signal	ON or OFF
Reverse range signal	R Range Signal	ON or OFF
Drive range signal	D Range Signal	ON or OFF
3rd range signal	3rd Range Signal	ON or OFF
2nd range signal	2nd Range Signal	ON or OFF
1st range signal	1st Range Signal	ON or OFF
Shift control solenoid A	Shift Solenoid #1	ON or OFF
Shift control solenoid B	Shift Solenoid #2	ON or OFF
Torque control output signal #1	Torque Control Signal #1	ON or OFF
Torque control output signal #2	Torque Control Signal #2	ON or OFF
Torque control cut signal	Torque Control Cut Sig.	ON or OFF
2-4 brake timing control solenoid valve	2-4 Brake Timing Sol.	ON or OFF
Low clutch timing control solenoid valve	Low Clutch Timing Sol.	ON or OFF
Automatic transmission diagnosis indicator lamp	AT Diagnosis Lamp	ON or OFF

NOTE:

For detailed operation procedure, refer to the SUBARU SELECT MONITOR OPERATION MANUAL.
For select monitor display details, refer to the following.

Front Wheel Speed

Display: 0 — 255 km/h (0 — 158 MPH)

The front wheel speed is displayed. This signal is used for the shift control, lock-up control, line pressure control, and transfer control.

ATF Temp.

Display: -40 to 215°C (-40 to 419°F)

The ATF temperature via the signal from the ATF temperature sensor is displayed.

Gear Position

Display:

The present gear position is displayed. The gear position is calculated from the engine speed and torque converter turbine speed.

Line Pressure Duty Ratio

Display: 0 — 123%

The duty value of the line pressure duty solenoid is displayed. The line pressure duty solenoid is regulated by the TCM, adjusting the line pressure to the optimum value depending on driving conditions.

Lock Up Duty Ratio

Display: 0 — 123%

The duty value of the lock-up duty solenoid is displayed. The lock-up duty solenoid is regulated by the TCM. Because the lock-up duty solenoid controls the lock-up control valve, the lock-up clutch engages and disengages smoothly.

SUBARU SELECT MONITOR

Engine (Diagnostics)

Transfer Duty Ratio

Display: 0 — 123%

The duty value of the transfer duty solenoid is displayed. The transfer duty solenoid is regulated by the TCM, adjusting the transfer clutch oil pressure and controlling the driving force of the rear wheels.

Turbine Revolution Speed

Display: 0 — 8,160 rpm

The input shaft speed detected by the torque converter speed sensor is displayed. This signal is used to control the line pressure and 2 - 4 brake pressure control timing during shifting.

Throttle Sensor Power

Display: 0 — 256 V

The supply voltage to the throttle sensor is displayed. This signal is used for the throttle sensor output correction.

Brake Clutch Duty Ratio

Display: 0 — 123%

The duty value of the 2 - 4 brake duty solenoid. The 2 - 4 brake duty solenoid is regulated by the TCM, adjusting the 2 - 4 brake pressure during shifting and relieving from harsh shifting.

Rear Wheel Speed

Display: 0 — 255 km/h (0 — 158 MPH)

The rear wheel speed is displayed. This signal is used to control the transfer. If the front vehicle speed sensor is malfunctioning, this signal is used as a substitute.

Cruise Control Signal

Display: ON or OFF

When the cruise control switch is ON, ON is displayed. When OFF, OFF is displayed.

ABS Signal

Display: ON or OFF

When the ABS function is active, ON is displayed. When inactive, OFF is displayed.

Stop Light Signal

Display: ON or OFF

When the brake pedal is depressed, ON is displayed. When released, OFF is displayed.

1st, 2nd, 3rd, D, R, Range Signal

Display: ON or OFF

When the switch for each range is ON, ON is displayed.

2-4 Brake Timing Sol.

Display: ON or OFF

When the 2 - 4 brake timing solenoid is ON, ON is displayed. When OFF, OFF is displayed. The 2 - 4 brake timing solenoid is regulated by the TCM, controlling the release timing of the 2 - 4 brake.

Low Clutch Timing Sol.

Display: ON or OFF

When the low clutch timing solenoid is ON, ON is displayed. When OFF, OFF is displayed. The low clutch timing solenoid is regulated by the TCM, controlling the release timing of the low clutch.

Shift Solenoid #1, #2

Display: ON or OFF

When the solenoid valve is ON, ON is displayed. When OFF, OFF is displayed. By combining No. 1 and No. 2 solenoids, the shifting mechanism is controlled.

P Range

Display: ON or OFF

When the shift lever stays in P range, ON is displayed. When not in P range, OFF is displayed.

N Range

Display: ON or OFF

When the shift lever stays in N range, ON is displayed. When not in N range, OFF is displayed.