

19. Diagnostic Procedure with Diagnostic Trouble Code (DTC) S078521

A: DTC P0031 — FRONT OXYGEN (A/F) SENSOR HEATER CIRCUIT LOW INPUT — S078521F83

- **DTC DETECTING CONDITION:**
 - Two consecutive driving cycles with fault

CAUTION:

After repair or replacement of faulty parts, conduct Clear Memory Mode <Ref. to EN-55, OPERATION, Clear Memory Mode.> and Inspection Mode <Ref. to EN-48, OPERATION, Inspection Mode.>.

● **WIRING DIAGRAM:**

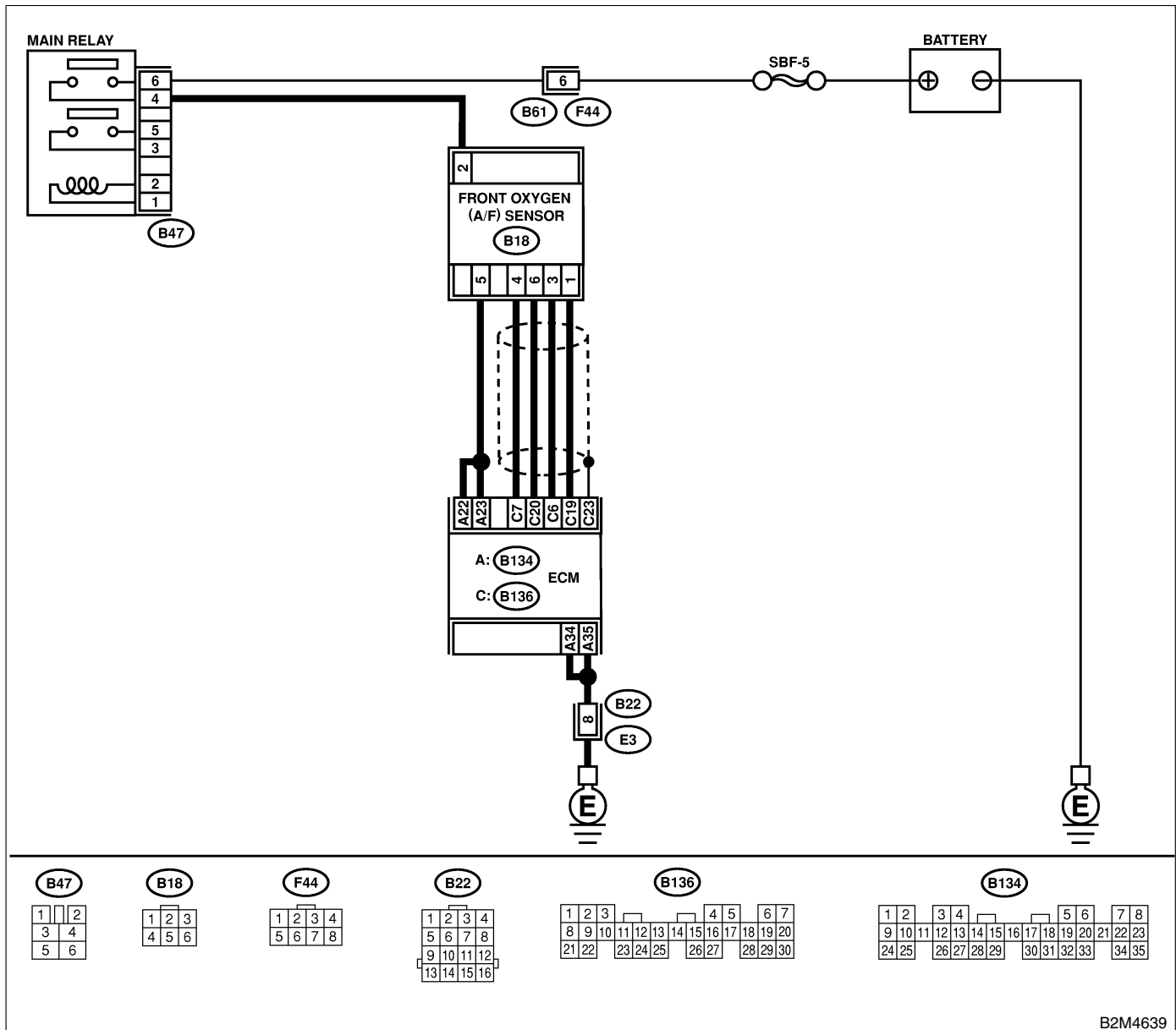

B2M4639

DIAGNOSTIC PROCEDURE WITH DIAGNOSTIC TROUBLE CODE (DTC)

Engine (Diagnostics)

No.	Step	Check	Yes	No
1	CHECK ANY OTHER DTC ON DISPLAY.	Does the Subaru Select Monitor or OBD-II general scan tool indicate DTC P1132 and P0141 at the same time?	Go to step 2.	Go to step 5.
2	CHECK POWER SUPPLY TO FRONT OXYGEN (A/F) SENSOR. 1) Turn ignition switch to OFF. 2) Disconnect connector from front oxygen (A/F) sensor. 3) Turn ignition switch to ON. 4) Measure voltage between front oxygen (A/F) sensor connector and engine ground. Connector & terminal (B18) No. 2 (+) — Engine ground (-):	Is the voltage more than 10 V?	Go to step 3.	Repair power supply line. NOTE: In this case, repair the following: ● Open circuit in harness between main relay and front oxygen (A/F) sensor connector ● Poor contact in front oxygen (A/F) sensor connector ● Poor contact in main relay connector
3	CHECK GROUND CIRCUIT OF ECM. Measure resistance of harness between ECM connector and chassis ground. Connector & terminal (B134) No. 35 — Chassis ground:	Is the resistance less than 5 Ω?	Go to step 4.	Repair harness and connector. NOTE: In this case, repair the following: ● Open circuit in harness between ECM and engine ground terminal ● Poor contact in ECM connector Poor contact in coupling connector
4	CHECK GROUND CIRCUIT OF ECM. 1) Measure resistance of harness between ECM connector and chassis ground. Connector & terminal (B134) No. 34 — Chassis ground:	Is there resistance less than 5 Ω?	Go to step 5.	Repair harness and connector. NOTE: In this case, repair the following: ● Open circuit in harness between ECM and engine ground terminal ● Poor contact in ECM connector Poor contact in coupling connector

DIAGNOSTIC PROCEDURE WITH DIAGNOSTIC TROUBLE CODE (DTC)

Engine (Diagnostics)

No.	Step	Check	Yes	No
5	<p>CHECK CURRENT DATA. 1) Start engine 2) Read data of front oxygen (A/F) sensor heater current using Subaru Select Monitor or OBD-II general scan tool. NOTE: ● Subaru Select Monitor For detailed operation procedure, refer to the "READ CURRENT DATA FOR ENGINE". <Ref. to EN-36, Subaru Select Monitor.> ● OBD-II scan tool For detailed operation procedures, refer to the OBD-II General Scan Tool Instruction Manual.</p>	Is the value more than 0.2 A?	Repair poor contact in connector. NOTE: In this case, repair the following: ● Poor contact in front oxygen (A/F) sensor connector ● Poor contact in ECM connector	Go to step 6.
6	<p>CHECK OUTPUT SIGNAL FROM ECM. 1) Start and idle the engine. 2) Measure voltage between ECM connector and chassis ground. Connector & terminal (B134) No. 22 (+) — Chassis ground (-):</p>	Is the voltage less than 1.0 V?	Go to step 8.	Go to step 7.
7	<p>CHECK OUTPUT SIGNAL FROM ECM. Measure voltage between ECM connector and chassis ground. Connector & terminal (B134) No. 22 (+) — Chassis ground (-):</p>	Does the voltage change less than 1.0 V by shaking harness and connector of ECM while monitoring the value with voltage meter?	Repair poor contact in ECM connector.	Go to step 8.
8	<p>CHECK OUTPUT SIGNAL FROM ECM. Measure voltage between ECM connector and chassis ground. Connector & terminal (B134) No. 23 (+) — Chassis ground (-):</p>	Is the voltage less than 1.0 V?	Go to step 10.	Go to step 9.
9	<p>CHECK OUTPUT SIGNAL FROM ECM. Measure voltage between ECM connector and chassis ground. Connector & terminal (B134) No. 23 (+) — Chassis ground (-):</p>	Does the voltage change less than 1.0 V by shaking harness and connector of ECM while monitoring the value with voltage meter?	Repair poor contact in ECM connector.	Go to step 10.
10	<p>CHECK FRONT OXYGEN (A/F) SENSOR. 1) Turn ignition switch to OFF. 2) Measure resistance between front oxygen (A/F) sensor connector terminals. Terminals No. 2 — No. 5:</p>	Is the resistance less than 10 Ω?	Repair harness and connector. NOTE: In this case, repair the following: ● Open or ground short circuit in harness between front oxygen (A/F) sensor and ECM connector ● Poor contact in front oxygen (A/F) sensor connector ● Poor contact in ECM connector	Replace front oxygen (A/F) sensor. <Ref. to EC-47, Front Oxygen (A/F) Sensor.>

MEMO:

DIAGNOSTIC PROCEDURE WITH DIAGNOSTIC TROUBLE CODE (DTC)

Engine (Diagnostics)

B: DTC P0032 — FRONT OXYGEN (A/F) SENSOR HEATER CIRCUIT HIGH INPUT — S078521F84

● DTC DETECTING CONDITION:

- Two consecutive driving cycles with fault

CAUTION:

After repair or replacement of faulty parts, conduct Clear Memory Mode <Ref. to EN-55, OPERATION, Clear Memory Mode.> and Inspection Mode <Ref. to EN-48, OPERATION, Inspection Mode.>.

● WIRING DIAGRAM:

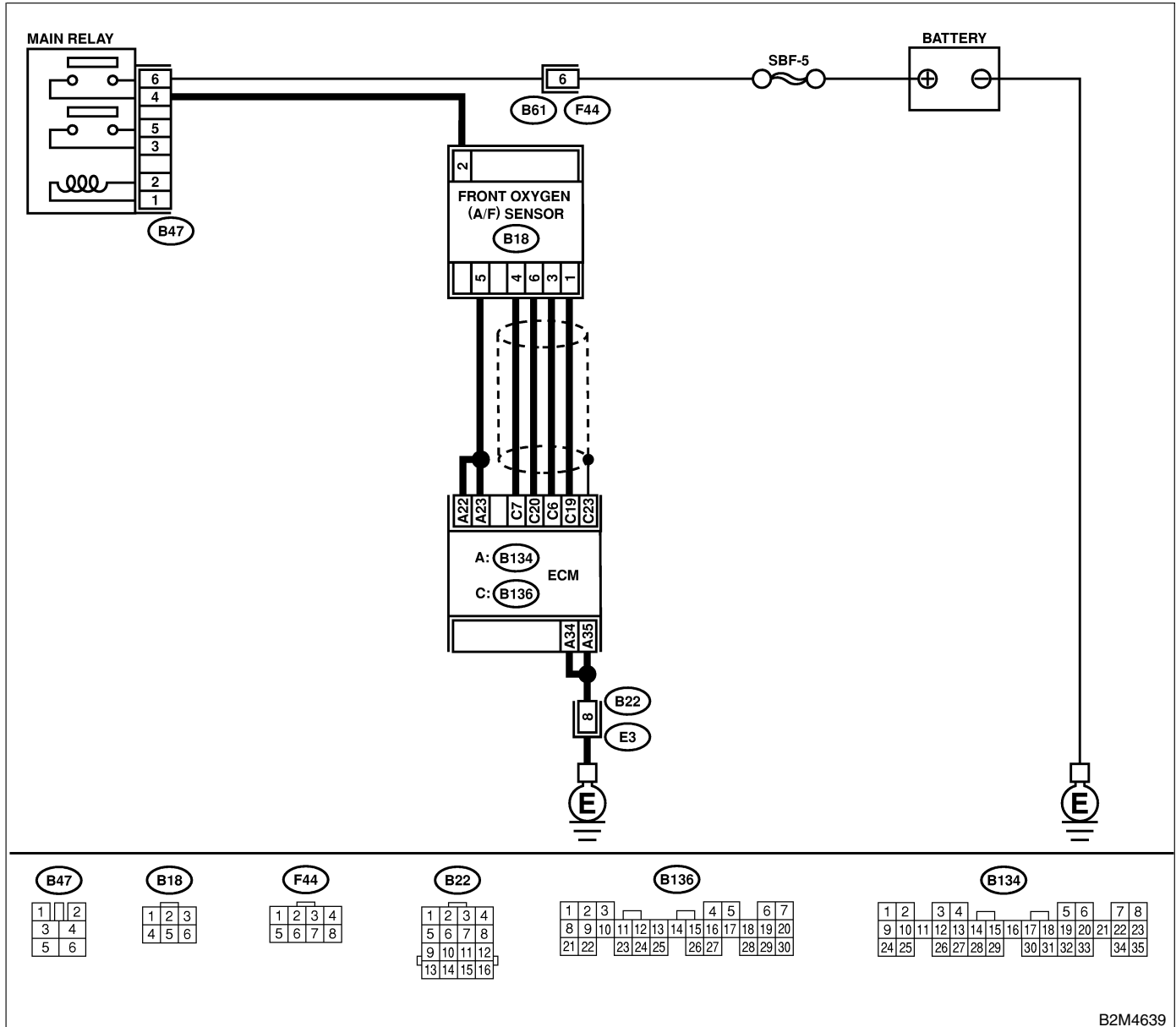

B2M4639

DIAGNOSTIC PROCEDURE WITH DIAGNOSTIC TROUBLE CODE (DTC)

Engine (Diagnostics)

No.	Step	Check	Yes	No
1	CHECK OUTPUT SIGNAL FROM ECM. 1) Turn ignition switch to ON. 2) Measure voltage between ECM connector and chassis ground. Connector & terminal (B134) No. 23 (+) — Chassis ground (-):	Is the voltage more than 8 V?	Go to step 3.	Go to step 2.
2	CHECK OUTPUT SIGNAL FROM ECM. Measure voltage between ECM connector and chassis ground. Connector & terminal (B134) No. 22 (+) — Chassis ground (-):	Is the voltage more than 8 V?	Go to step 3.	Go to step 4.
3	CHECK FRONT OXYGEN (A/F) SENSOR HEATER CURRENT. 1) Turn ignition switch to OFF. 2) Repair battery short circuit in harness between ECM and front oxygen (A/F) sensor connector. 3) Turn ignition switch to ON. 4) Read data of front oxygen (A/F) sensor heater current using Subaru Select Monitor or the OBD-II general scan tool. NOTE: ● Subaru Select Monitor For detailed operation procedure, refer to the "READ CURRENT DATA FOR ENGINE". <Ref. to EN-36, Subaru Select Monitor.> ● OBD-II general scan tool For detailed operation procedure, refer to the OBD-II General Scan Tool Instruction Manual.	Is the value more than 2.3 A?	Replace ECM. <Ref. to FU-51, Engine Control Module.>	END
4	CHECK OUTPUT SIGNAL FROM ECM. Measure voltage between ECM connector and chassis ground. Connector & terminal (B134) No. 23 (+) — Chassis ground (-):	Does the voltage change more than 8 V by shaking harness and connector of ECM while monitoring the value with voltage meter?	Repair battery short circuit in harness between ECM and front oxygen (A/F) sensor connector.	Go to step 5.
5	CHECK OUTPUT SIGNAL FROM ECM. Measure voltage between ECM connector and chassis ground. Connector & terminal (B134) No. 22 (+) — Chassis ground (-):	Does the voltage change more than 8 V by shaking harness and connector of ECM while monitoring the value with voltage meter?	Repair battery short circuit in harness between ECM and front oxygen (A/F) sensor connector.	END

DIAGNOSTIC PROCEDURE WITH DIAGNOSTIC TROUBLE CODE (DTC)

Engine (Diagnostics)

C: DTC P0037 — REAR OXYGEN SENSOR HEATER CIRCUIT LOW INPUT —

S078521G89

● DTC DETECTING CONDITION:

- Two consecutive driving cycles with fault

CAUTION:

After repair or replacement of faulty parts, conduct Clear Memory Mode <Ref. to EN-55, OPERATION, Clear Memory Mode.> and Inspection Mode <Ref. to EN-48, OPERATION, Inspection Mode.>.

● WIRING DIAGRAM:

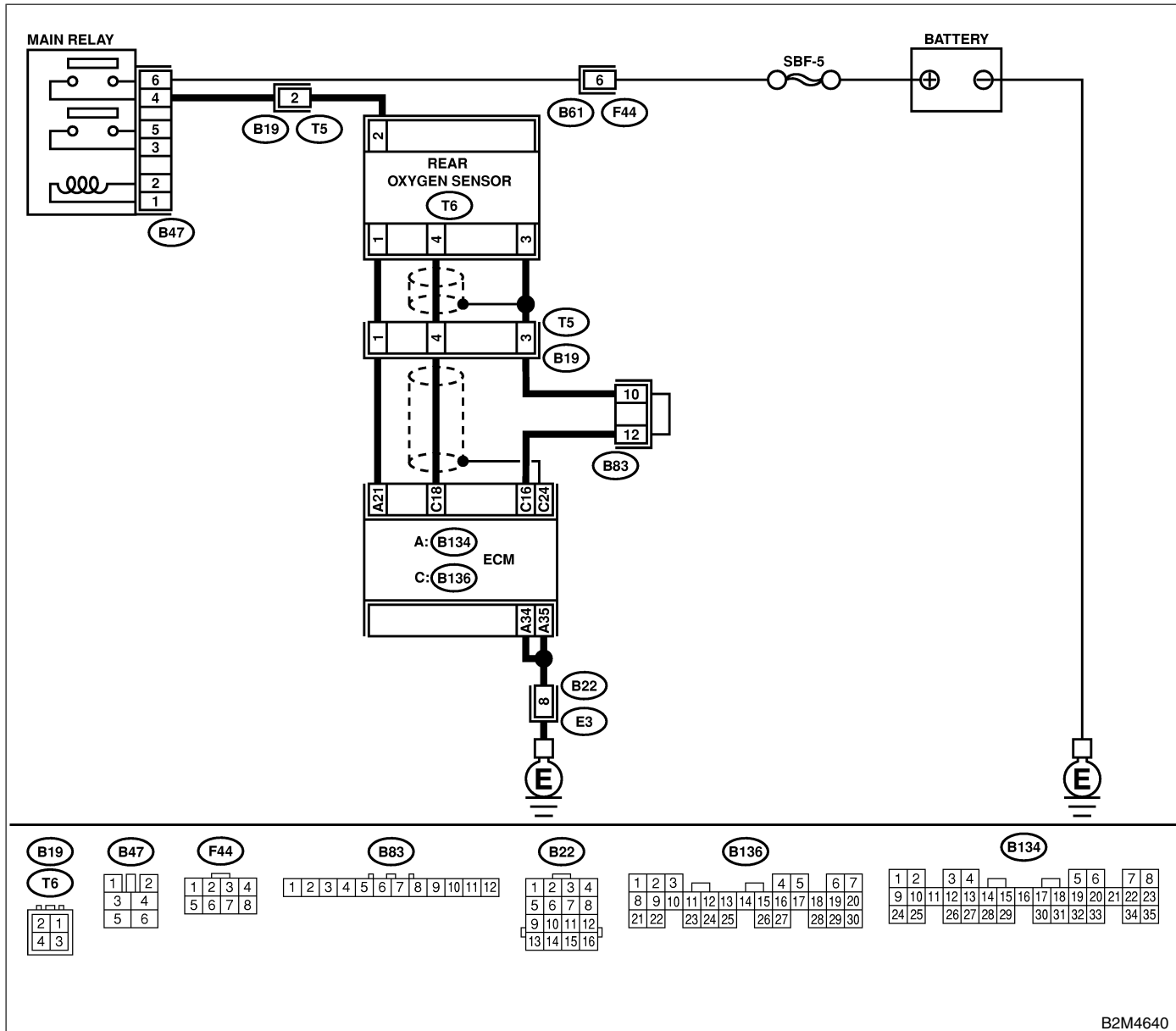

B2M4640

No.	Step	Check	Yes	No
1	CHECK GROUND CIRCUIT OF ECM. 1) Turn ignition switch to OFF. 2) Disconnect connector from ECM. 3) Measure resistance of harness between ECM connector and chassis ground. <i>Connector & terminal</i> <i>(B134) No. 35 — Chassis ground:</i>	Is the resistance less than 5 Ω?	Go to step 3.	Go to step 2.

DIAGNOSTIC PROCEDURE WITH DIAGNOSTIC TROUBLE CODE (DTC)

Engine (Diagnostics)

No.	Step	Check	Yes	No
2	<p>CHECK GROUND CIRCUIT OF ECM.</p> <p>1) Repair harness and connector.</p> <p>NOTE: In this case, repair the following:</p> <ul style="list-style-type: none"> ● Open circuit in harness between ECM and engine ground terminal ● Poor contact in ECM connector ● Poor contact in coupling connector (B22) <p>2) Measure resistance of harness between ECM connector and chassis ground.</p> <p>Connector & terminal (B134) No. 34 — Chassis ground:</p>	Is the resistance less than 5 Ω?	Go to step 3.	Repair harness and connector. NOTE: In this case, repair the following: ● Open circuit in harness between ECM and engine ground terminal ● Poor contact in ECM connector ● Poor contact in coupling connector
3	<p>CHECK CURRENT DATA.</p> <p>1) Start engine.</p> <p>2) Read data of rear oxygen sensor heater current using Subaru Select Monitor or OBD-II general scan tool.</p> <p>NOTE: ● Subaru Select Monitor For detailed operation procedure, refer to the "READ CURRENT DATA FOR ENGINE". <Ref. to EN-36, Subaru Select Monitor.> ● OBD-II scan tool For detailed operation procedures, refer to the OBD-II General Scan Tool Instruction Manual.</p>	Is the value more than 0.2 A?	Repair connector. NOTE: In this case, repair the following: ● Poor contact in rear oxygen sensor connector ● Poor contact in rear oxygen sensor connecting harness connector ● Poor contact in ECM connector	Go to step 4.
4	<p>CHECK OUTPUT SIGNAL FROM ECM.</p> <p>1) Start and idle the engine.</p> <p>2) Measure voltage between ECM connector and chassis ground.</p> <p>Connector & terminal (B134) No. 21 (+) — Chassis ground (-):</p>	Is the voltage less than 1.0 V?	Go to step 7.	Go to step 5.
5	<p>CHECK OUTPUT SIGNAL FROM ECM.</p> <p>Measure voltage between ECM connector and chassis ground.</p> <p>Connector & terminal (B134) No. 21 (+) — Chassis ground (-):</p>	Does the voltage change less than 1.0 V by shaking harness and connector of ECM while monitoring the value with voltage meter?	Repair poor contact in ECM connector.	Go to step 6.
6	<p>CHECK OUTPUT SIGNAL FROM ECM.</p> <p>1) Disconnect connector from rear oxygen sensor.</p> <p>2) Measure voltage between ECM connector and chassis ground.</p> <p>Connector & terminal (B134) No. 21 (+) — Chassis ground (-):</p>	Is the voltage less than 1.0 V?	Contact with SOA (distributor) service. NOTE: Inspection by DTM is required, because probable cause is deterioration of multiple parts.	Repair battery short circuit in harness between ECM and rear oxygen sensor connector. After repair, replace ECM. <Ref. to FU-51, Engine Control Module.>

DIAGNOSTIC PROCEDURE WITH DIAGNOSTIC TROUBLE CODE (DTC)

Engine (Diagnostics)

No.	Step	Check	Yes	No
7	<p>CHECK POWER SUPPLY TO REAR OXYGEN SENSOR.</p> <p>1) Turn ignition switch to OFF. 2) Disconnect connector from rear oxygen sensor. 3) Turn ignition switch to ON. 4) Measure voltage between rear oxygen sensor connector and engine ground or chassis ground.</p> <p>Connector & terminal (T6) No. 2 (+) — Chassis ground (-):</p>	<p>Is the voltage more than 10 V?</p>	<p>Go to step 8.</p>	<p>Repair power supply line. NOTE: In this case, repair the following:</p> <ul style="list-style-type: none"> ● Open circuit in harness between main relay and rear oxygen sensor connector ● Poor contact in rear oxygen sensor connector ● Poor contact in coupling connector
8	<p>CHECK REAR OXYGEN SENSOR.</p> <p>1) Turn ignition switch to OFF. 2) Measure resistance between rear oxygen sensor connector terminals.</p> <p>Terminals No. 1 — No. 2:</p>	<p>Is the resistance less than 30 Ω?</p>	<p>Repair harness and connector. NOTE: In this case, repair the following:</p> <ul style="list-style-type: none"> ● Open circuit in harness between rear oxygen sensor and ECM connector ● Poor contact in rear oxygen sensor connector ● Poor contact in ECM connector ● Poor contact in coupling connector 	<p>Replace rear oxygen sensor. <Ref. to FU-49, Rear Oxygen Sensor.></p>

MEMO:

DIAGNOSTIC PROCEDURE WITH DIAGNOSTIC TROUBLE CODE (DTC)

Engine (Diagnostics)

D: DTC P0038 — REAR OXYGEN SENSOR HEATER CIRCUIT HIGH INPUT —

S078521F86

● DTC DETECTING CONDITION:

- Two consecutive driving cycles with fault

CAUTION:

After repair or replacement of faulty parts, conduct Clear Memory Mode <Ref. to EN-55, OPERATION, Clear Memory Mode.> and Inspection Mode <Ref. to EN-48, OPERATION, Inspection Mode.>.

● WIRING DIAGRAM:

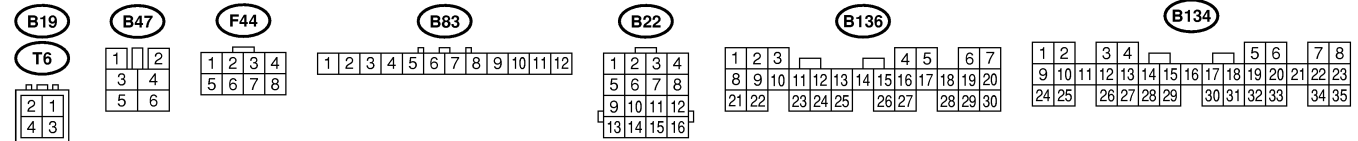
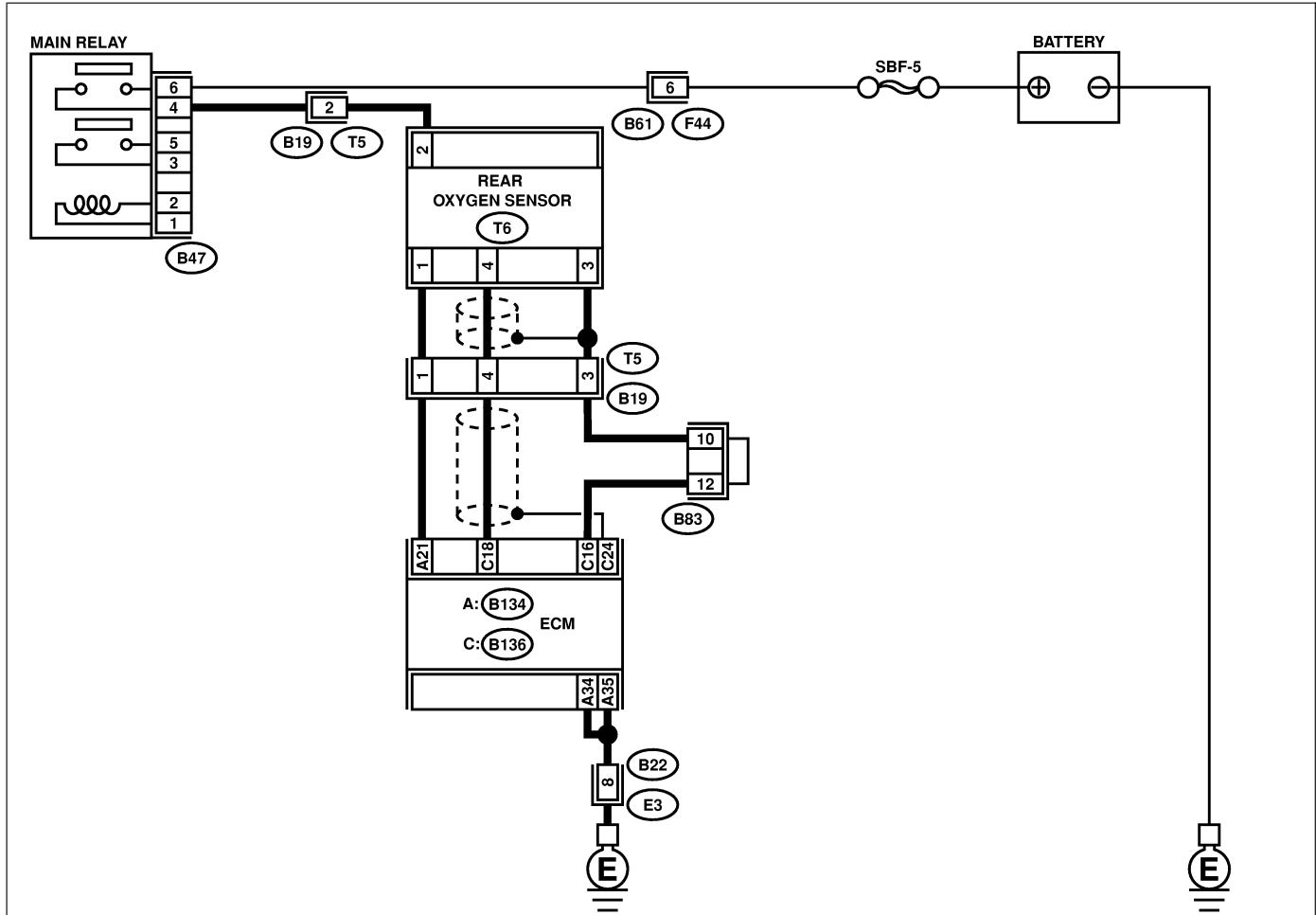

B2M4640

No.	Step	Check	Yes	No
1	CHECK INPUT SIGNAL FOR ECM. Measure voltage between ECM connector and chassis ground. Connector & terminal (B134) No. 21 (+) — Chassis ground (-):	Is the voltage more than 8 V?	Go to step 2.	Go to step 3.

DIAGNOSTIC PROCEDURE WITH DIAGNOSTIC TROUBLE CODE (DTC)

Engine (Diagnostics)

No.	Step	Check	Yes	No
2	<p>CHECK CURRENT DATA.</p> <p>1) Turn ignition switch to OFF. 2) Repair battery short circuit in harness between ECM and rear oxygen sensor connector. 3) Turn ignition switch to ON. 4) Read data of rear oxygen sensor heater current using Subaru Select Monitor or the OBD-II general scan tool.</p> <p>NOTE:</p> <ul style="list-style-type: none">● Subaru Select Monitor For detailed operation procedure, refer to the "READ CURRENT DATA FOR ENGINE". <Ref. to EN-36, Subaru Select Monitor.>● OBD-II general scan tool For detailed operation procedure, refer to the OBD-II General Scan Tool Instruction Manual.	Is the value more than 7 A?	Replace ECM. <Ref. to FU-51, Engine Control Module.>	END
3	<p>CHECK POOR CONTACT.</p> <p>Check poor contact in ECM connector.</p>	Is there poor contact in ECM connector?	Repair poor contact in ECM connector.	END

DIAGNOSTIC PROCEDURE WITH DIAGNOSTIC TROUBLE CODE (DTC)

Engine (Diagnostics)

E: DTC P0065 — AIR ASSIST INJECTOR SOLENOID VALVE MALFUNCTION

S078521F87

- **DTC DETECTING CONDITION:**
 - Two consecutive driving cycles with fault
- **TROUBLE SYMPTOM:**
 - Erroneous idling
 - Engine stalls.

CAUTION:

After repair or replacement of faulty parts, conduct Clear Memory Mode <Ref. to EN-55, OPERATION, Clear Memory Mode.> and Inspection Mode <Ref. to EN-48, OPERATION, Inspection Mode.>.

● WIRING DIAGRAM:

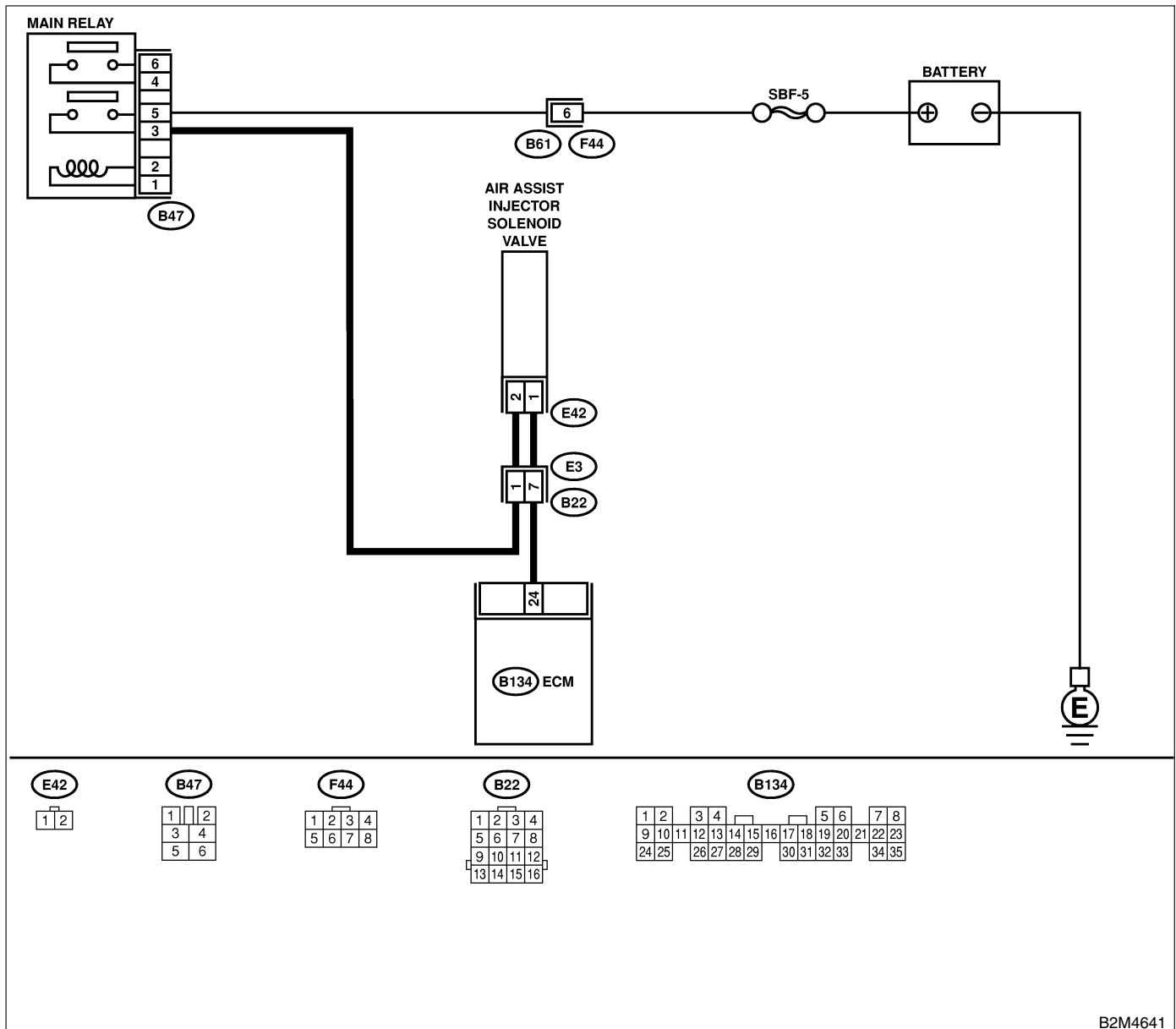

B2M4641

DIAGNOSTIC PROCEDURE WITH DIAGNOSTIC TROUBLE CODE (DTC)

Engine (Diagnostics)

No.	Step	Check	Yes	No
1	CHECK ANY OTHER DTC ON DISPLAY.	Is any other DTC displayed?	Inspect the relevant DTC using "List of Diagnostic Trouble Code (DTC)". <Ref. to EN-88, List of Diagnostic Trouble Code (DTC).>	Go to step 2.
2	CHECK AIR ASSIST INJECTOR SOLENOID VALVE OPERATION. 1) Turn ignition switch to OFF. 2) Connect test mode connector at the lower portion of instrument panel (on the driver's side), to the side of the center console box. 3) Turn ignition switch to ON. 4) Operate air assist injector solenoid valve. NOTE: Air assist injector solenoid valve operation can also be executed using Subaru Select Monitor. For the procedure, refer to the "Compulsory Valve Operation Check Mode". <Ref. to EN-56, Compulsory Valve Operation Check Mode.>	Does air assist injector solenoid valve operating sound?	Go to step 3.	Replace air assist injector solenoid valve. <Ref. to FU-40, Air Assist Injector Solenoid Valve.>
3	CHECK AIR BY-PASS HOSES. Use your mouth to blow through air by-pass hose to make sure that there is a smooth air flow (no clogging).	Is air by-pass hose damaged?	Repair or replace air by-pass hoses.	Go to step 4.
4	CHECK FUEL INJECTOR. 1) Turn ignition switch to OFF. 2) Remove fuel injector. <Ref. to FU-41, REMOVAL, Fuel Injector.> 3) Check for clogged fuel injectors.	Is fuel injector clogged?	Replace fuel injector. <Ref. to FU-41, INSTALLATION, Fuel Injector.>	Replace air assist injector solenoid valve. <Ref. to FU-40, Air Assist Injector Solenoid Valve.>

DIAGNOSTIC PROCEDURE WITH DIAGNOSTIC TROUBLE CODE (DTC)

Engine (Diagnostics)

F: DTC P0066 — AIR ASSIST INJECTOR SOLENOID VALVE CIRCUIT LOW INPUT — S078521F88

● DTC DETECTING CONDITION:

- Two consecutive driving cycles with fault

● TROUBLE SYMPTOM:

- Erroneous idling
- Engine stalls.

CAUTION:

After repair or replacement of faulty parts, conduct Clear Memory Mode <Ref. to EN-55, OPERATION, Clear Memory Mode.> and Inspection Mode <Ref. to EN-48, OPERATION, Inspection Mode.>.

● WIRING DIAGRAM:

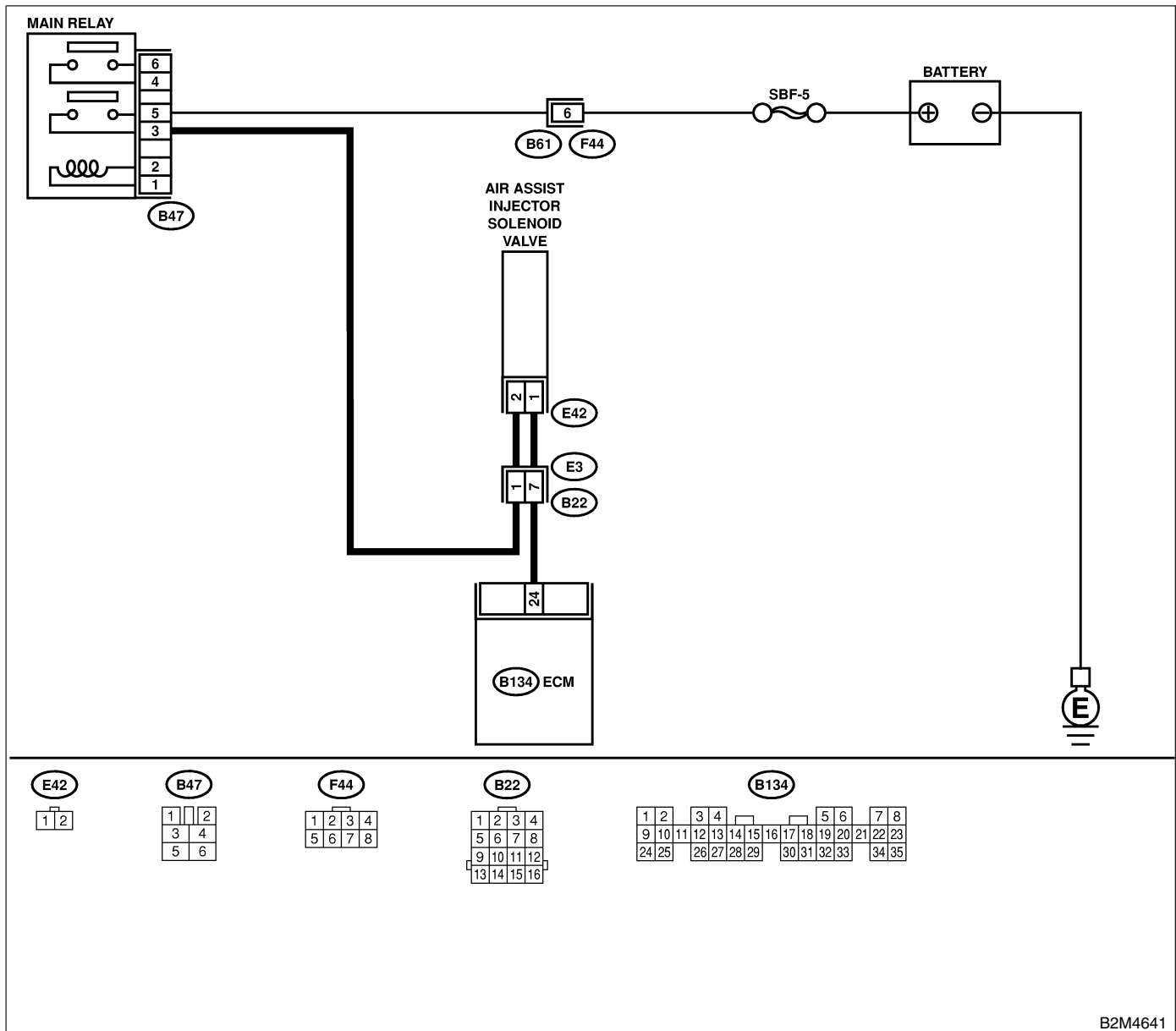

B2M4641

DIAGNOSTIC PROCEDURE WITH DIAGNOSTIC TROUBLE CODE (DTC)

Engine (Diagnostics)

No.	Step	Check	Yes	No
1	<p>CHECK OUTPUT SIGNAL FROM ECM. 1) Turn ignition switch to ON. 2) Measure voltage between ECM and chassis ground. Connector & terminal <i>(B134) No. 24 (+) — Chassis ground (-):</i></p>	Is the voltage more than 10 V?	Repair poor contact in ECM connector.	Go to step 2.
2	<p>CHECK POWER SUPPLY TO AIR ASSIST INJECTOR SOLENOID VALVE. 1) Turn ignition switch to OFF. 2) Disconnect connector from air assist injector solenoid valve. 3) Turn ignition switch to ON. 4) Measure voltage between air assist injector solenoid valve and engine ground. Connector & terminal <i>(E42) No. 2 (+) — Engine ground (-):</i></p>	Is the voltage more than 10 V?	Go to step 3.	Repair harness and connector. NOTE: In this case, repair the following: <ul style="list-style-type: none"> ● Open circuit in harness between air assist injector solenoid valve and main relay connector ● Poor contact in coupling connector
3	<p>CHECK HARNESS BETWEEN ECM AND AIR ASSIST INJECTOR SOLENOID VALVE CONNECTOR. 1) Turn ignition switch to OFF. 2) Disconnect connector from ECM. 3) Measure resistance of harness between ECM and air assist injector solenoid valve connector. Connector & terminal <i>(B134) No. 24 — (E42) No. 1:</i></p>	Is the resistance less than 1 Ω ?	Go to step 4.	Repair harness and connector. NOTE: In this case, repair the following: <ul style="list-style-type: none"> ● Open circuit in harness between ECM and air assist injector solenoid valve connector ● Poor contact in coupling connector
4	<p>CHECK HARNESS BETWEEN ECM AND AIR ASSIST INJECTOR SOLENOID VALVE CONNECTOR. Measure resistance of harness between ECM and chassis ground. Connector & terminal <i>(B134) No. 24 — Chassis ground:</i></p>	Is the resistance more than 1 M Ω ?	Go to step 5.	Repair ground short circuit in harness between ECM and air assist injector solenoid valve connector.
5	<p>CHECK POOR CONTACT. Check poor contact in ECM and air assist injector solenoid valve connectors.</p>	Is there poor contact in ECM and air assist injector solenoid valve connectors?	Repair poor contact in ECM and air assist injector solenoid valve connectors.	Replace air assist injector solenoid valve. <Ref. to FU-40, Air Assist Injector Solenoid Valve.>

DIAGNOSTIC PROCEDURE WITH DIAGNOSTIC TROUBLE CODE (DTC)

Engine (Diagnostics)

G: DTC P0067 — AIR ASSIST INJECTOR SOLENOID VALVE CIRCUIT HIGH INPUT — S078521G72

● DTC DETECTING CONDITION:

- Two consecutive driving cycles with fault

● TROUBLE SYMPTOM:

- Erroneous idling
- Engine stalls.

CAUTION:

After repair or replacement of faulty parts, conduct Clear Memory Mode <Ref. to EN-55, OPERATION, Clear Memory Mode.> and Inspection Mode <Ref. to EN-48, OPERATION, Inspection Mode.>.

● WIRING DIAGRAM:

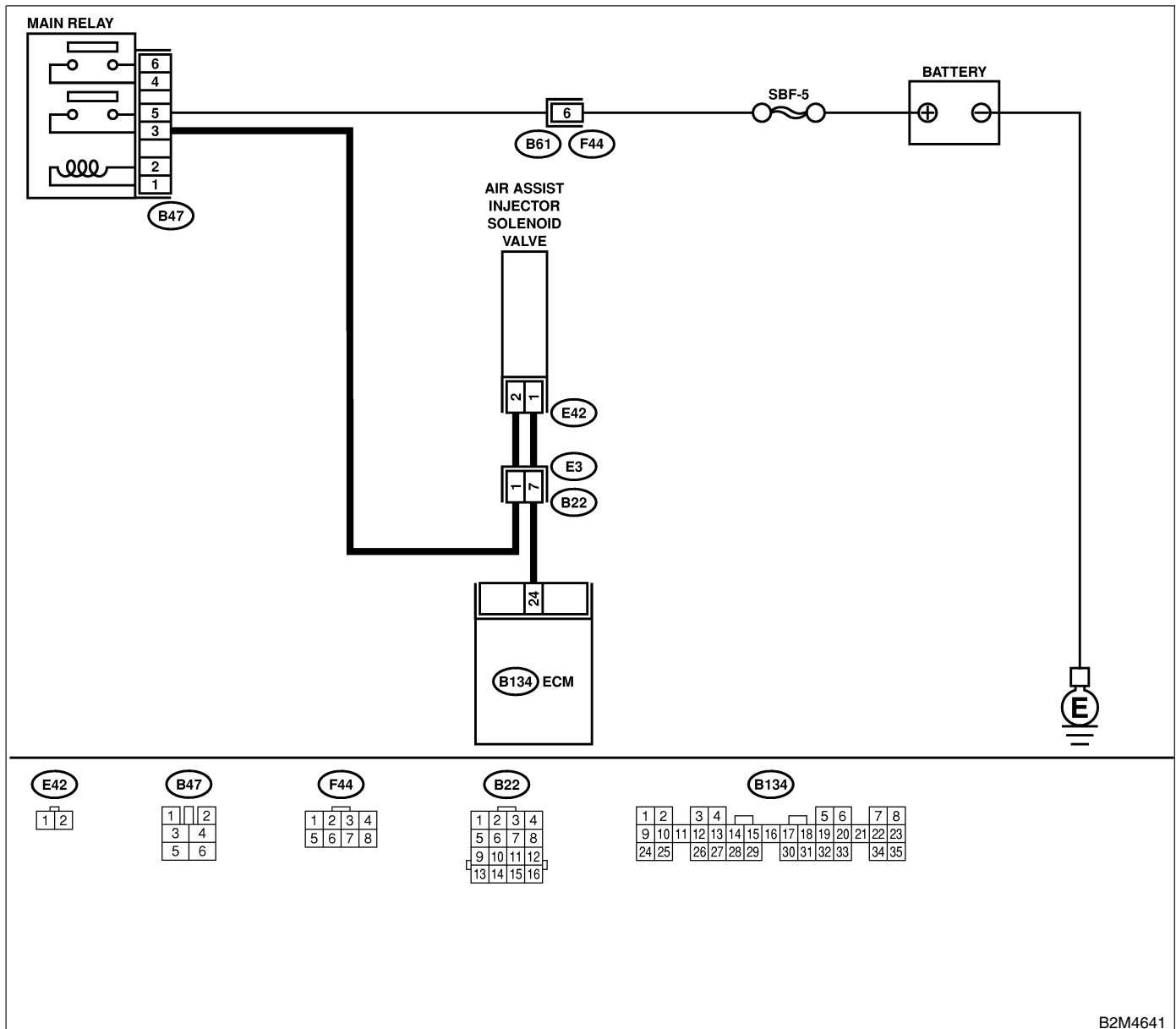

B2M4641

DIAGNOSTIC PROCEDURE WITH DIAGNOSTIC TROUBLE CODE (DTC)

Engine (Diagnostics)

No.	Step	Check	Yes	No
1	<p>CHECK OUTPUT SIGNAL FROM ECM. 1) Turn ignition switch to ON. 2) Measure voltage between ECM and chassis ground. Connector & terminal <i>(B134) No. 24 (+) — Chassis ground (-):</i></p>	Is the voltage more than 10 V?	Go to step 2.	Go to step 3.
2	<p>CHECK OUTPUT SIGNAL FROM ECM. 1) Turn ignition switch to OFF. 2) Disconnect connector from air assist injector solenoid valve. 3) Turn ignition switch to ON. 4) Measure voltage between ECM and chassis ground. Connector & terminal <i>(B134) No. 24 (+) — Chassis ground (-):</i></p>	Is the voltage more than 10 V?	Repair battery short circuit in harness between ECM and air assist injector solenoid valve connector. After repair, replace ECM. <Ref. to FU-51, Engine Control Module.>	Replace air assist injector solenoid valve <Ref. to FU-40, Air Assist Injector Solenoid Valve.> and ECM <Ref. to FU-51, Engine Control Module.>
3	<p>CHECK OUTPUT SIGNAL FROM ECM. Measure voltage between ECM and chassis ground. Connector & terminal <i>(B134) No. 24 (+) — Chassis ground (-):</i></p>	Does the voltage change more than 10 V by shaking harness and connector of ECM while monitoring the value with voltage meter?	Repair battery short circuit in harness between ECM and air assist injector solenoid valve connector. After repair, replace ECM. <Ref. to FU-51, Engine Control Module.>	Contact with SOA (distributor) service. NOTE: Inspection by DTM is required, because probable cause is deterioration of multiple parts.

DIAGNOSTIC PROCEDURE WITH DIAGNOSTIC TROUBLE CODE (DTC)

Engine (Diagnostics)

H: DTC P0106 — PRESSURE SENSOR CIRCUIT RANGE/PERFORMANCE PROBLEM (LOW INPUT) — S078521F90

● DTC DETECTING CONDITION:

- Two consecutive driving cycles with fault

CAUTION:

After repair or replacement of faulty parts, conduct Clear Memory Mode <Ref. to EN-55, OPERATION, Clear Memory Mode.> and Inspection Mode <Ref. to EN-48, OPERATION, Inspection Mode.>.

● WIRING DIAGRAM:

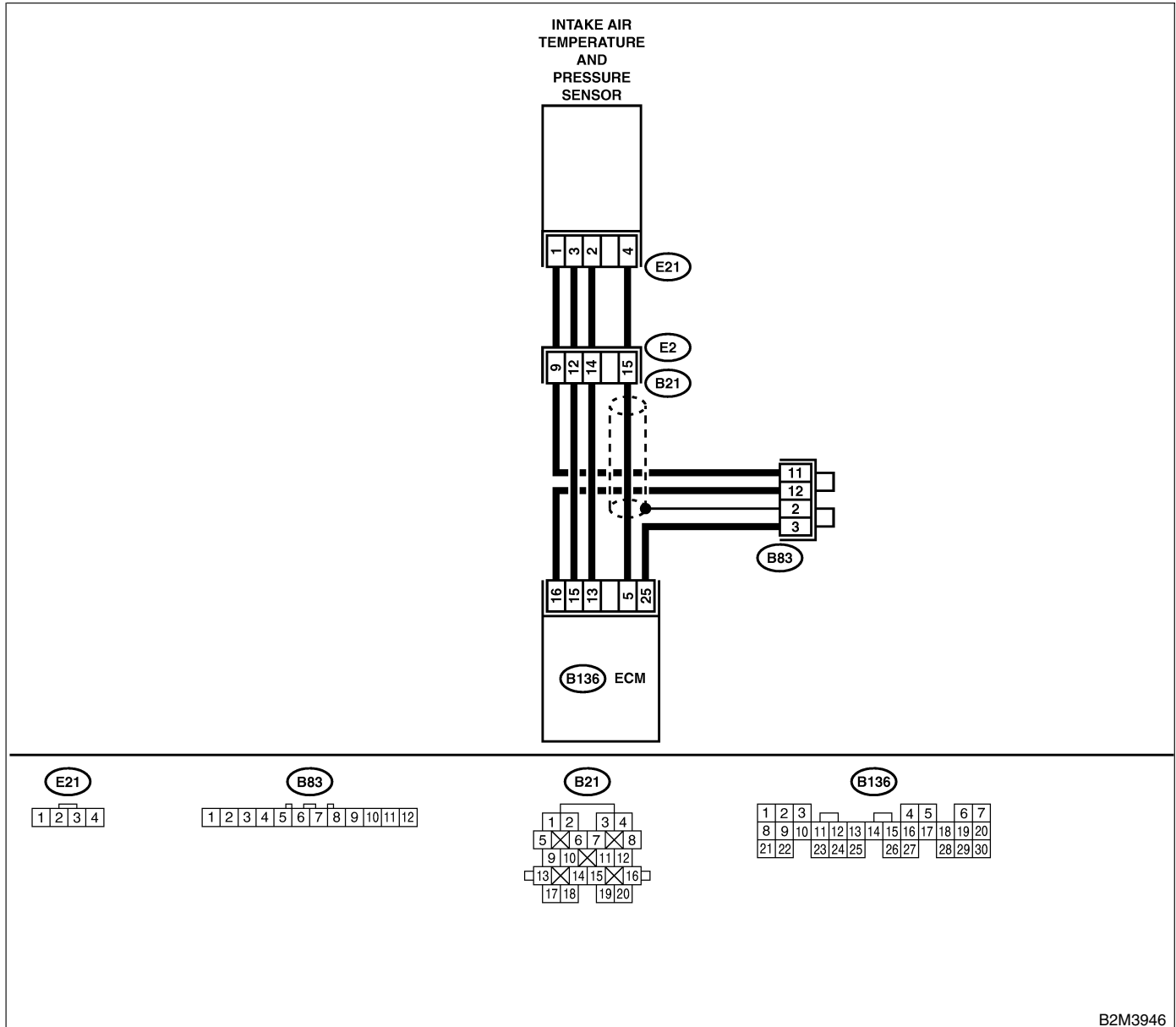

B2M3946

DIAGNOSTIC PROCEDURE WITH DIAGNOSTIC TROUBLE CODE (DTC)

Engine (Diagnostics)

No.	Step	Check	Yes	No
1	<p>CHECK ANY OTHER DTC ON DISPLAY.</p> <p>NOTE: In this case, it is not necessary to inspect DTC P0106.</p>	Is any other DTC displayed?	Inspect the relevant DTC using "List of Diagnostic Trouble Code (DTC)". <Ref. to EN-88, List of Diagnostic Trouble Code (DTC).>	Go to step 2.
2	<p>CHECK AIR INTAKE SYSTEM.</p>	Are there holes, loose bolts or disconnection of hose on air intake system?	Repair air intake system.	Go to step 3.
3	<p>CHECK PRESSURE SENSOR.</p> <p>1) Start the engine and warm-up engine until coolant temperature is greater than 60°C (140°F). 2) Place the shift lever in the selector lever in "N" or "P" position. 3) Turn A/C switch to OFF. 4) Turn all accessory switches to OFF. 5) Read data of intake manifold pressure sensor signal using Subaru Select Monitor or OBD-II general scan tool.</p> <p>NOTE:</p> <ul style="list-style-type: none"> ● Subaru Select Monitor For detailed operation procedure, refer to the "READ CURRENT DATA FOR ENGINE". <Ref. to EN-36, Subaru Select Monitor.> ● OBD-II general scan tool For detailed operation procedure, refer to the OBD-II General Scan Tool Instruction Manual. <p>Specification:</p> <ul style="list-style-type: none"> ● Intake manifold absolute pressure <p>Ignition ON 73.3 — 106.6 kPa (550 — 800 mmHg, 21.65 — 31.50 inHg)</p> <p>Idling 20.0 — 46.7 kPa (150 — 350 mmHg, 5.91 — 13.78 inHg)</p>	Is the value within the specifications?	Go to step 4.	Replace intake air temperature sensor and pressure sensor. <Ref. to FU-38, Intake Air Temperature and Pressure Sensor.>
4	<p>CHECK THROTTLE POSITION.</p> <p>Read data of throttle position signal using Subaru Select Monitor or OBD-II general scan tool.</p> <p>NOTE:</p> <ul style="list-style-type: none"> ● Subaru Select Monitor For detailed operation procedure, refer to the "READ CURRENT DATA FOR ENGINE". <Ref. to EN-36, Subaru Select Monitor.> ● OBD-II general scan tool For detailed operation procedure, refer to the OBD-II General Scan Tool Instruction Manual. 	Is throttle positioning ratio equal to or less than 5% when throttle is fully closed?	Go to step 5.	Adjust or replace throttle position sensor. <Ref. to FU-35, Throttle Position Sensor.>
5	<p>CHECK THROTTLE POSITION.</p>	Is throttle positioning ratio equal to or more than 85% when throttle is fully open?	Replace intake air temperature and pressure sensor. <Ref. to FU-38, Intake Air Temperature and Pressure Sensor.>	Replace throttle position sensor. <Ref. to FU-35, Throttle Position Sensor.>

DIAGNOSTIC PROCEDURE WITH DIAGNOSTIC TROUBLE CODE (DTC)

Engine (Diagnostics)

I: DTC P0107 — PRESSURE SENSOR CIRCUIT LOW INPUT — S078521B12

- DTC DETECTING CONDITION:
 - Immediately at fault recognition

CAUTION:

After repair or replacement of faulty parts, conduct Clear Memory Mode <Ref. to EN-55, OPERATION, Clear Memory Mode.> and Inspection Mode <Ref. to EN-48, OPERATION, Inspection Mode.>.

- WIRING DIAGRAM:

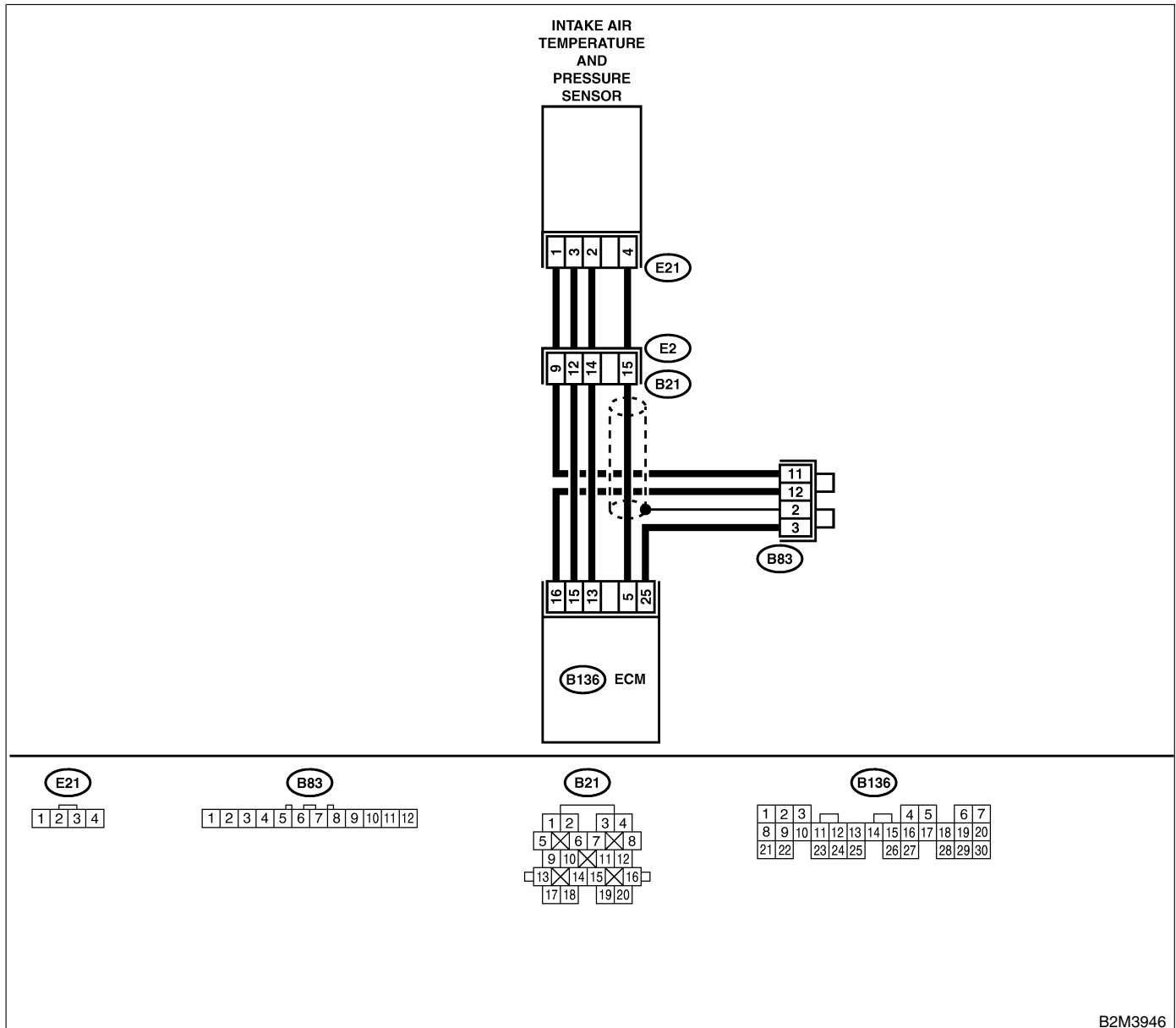

DIAGNOSTIC PROCEDURE WITH DIAGNOSTIC TROUBLE CODE (DTC)

Engine (Diagnostics)

No.	Step	Check	Yes	No
1	<p>CHECK CURRENT DATA. 1) Start engine. 2) Read the data of intake manifold absolute pressure signal using Subaru Select Monitor or OBD-II general scan tool. NOTE: ● Subaru Select Monitor For detailed operation procedure, refer to the "READ CURRENT DATA FOR ENGINE". <Ref. to EN-36, Subaru Select Monitor.> ● OBD-II general scan tool For detailed operation procedures, refer to the OBD-II General Scan Tool Instruction Manual.</p>	Is the value less than 13.3 kPa (100 mmHg, 3.94 inHg)?	Go to step 3.	Go to step 2.
2	<p>CHECK POOR CONTACT. Check poor contact in ECM and pressure sensor connector.</p>	Is there poor contact in ECM or pressure sensor connector?	Repair poor contact in ECM or pressure sensor connector.	Even if MIL lights up, the circuit has returned to a normal condition at this time.
3	<p>CHECK INPUT SIGNAL FOR ECM. Measure voltage between ECM connector and chassis ground. <i>Connector & terminal</i> <i>(B136) No. 15 (+) — Chassis ground (-):</i></p>	Is the voltage more than 4.5 V?	Go to step 5.	Go to step 4.
4	<p>CHECK INPUT SIGNAL FOR ECM. Measure voltage between ECM connector and chassis ground. <i>Connector & terminal</i> <i>(B136) No. 15 (+) — Chassis ground (-):</i></p>	Does the voltage change more than 4.5 V by shaking harness and connector of ECM while monitoring the value with voltage meter?	Repair poor contact in ECM connector.	Contact with SOA (distributor) service. NOTE: Inspection by DTM is required, because probable cause is deterioration of multiple parts.
5	<p>CHECK INPUT SIGNAL FOR ECM. Measure voltage between ECM and chassis ground. <i>Connector & terminal</i> <i>(B136) No. 5 (+) — Chassis ground (-):</i></p>	Is the voltage less than 0.2 V?	Go to step 7.	Go to step 6.
6	<p>CHECK INPUT SIGNAL FOR ECM. (USING SUBARU SELECT MONITOR.) Read data of atmospheric absolute pressure signal using Subaru Select Monitor. NOTE: ● Subaru Select Monitor For detailed operation procedure, refer to the "READ CURRENT DATA FOR ENGINE". <Ref. to EN-36, Subaru Select Monitor.></p>	Does the value change more than 13.3 kPa (100 mmHg, 3.94 inHg) by shaking harness and connector of ECM while monitoring the value with Subaru Select Monitor?	Repair poor contact in ECM connector.	Go to step 7.
7	<p>CHECK HARNESS BETWEEN ECM AND INTAKE AIR TEMPERATURE AND PRESSURE SENSOR CONNECTOR. 1) Turn ignition switch to OFF. 2) Disconnect connector from intake air temperature and pressure sensor. 3) Turn ignition switch to ON. 4) Measure voltage between intake air temperature sensor and pressure sensor connector and engine ground. <i>Connector & terminal</i> <i>(E21) No. 3 (+) — Engine ground (-):</i></p>	Is the voltage more than 4.5 V?	Go to step 8.	Repair open circuit in harness between ECM and intake air temperature and pressure sensor connector.

DIAGNOSTIC PROCEDURE WITH DIAGNOSTIC TROUBLE CODE (DTC)

Engine (Diagnostics)

No.	Step	Check	Yes	No
8	<p>CHECK HARNESS BETWEEN ECM AND INTAKE AIR TEMPERATURE AND PRESSURE SENSOR CONNECTOR. 1) Turn ignition switch to OFF. 2) Disconnect connector from ECM. 3) Measure resistance of harness between ECM and intake air temperature and pressure sensor connector.</p> <p>Connector & terminal (B136) No. 16 — (E21) No. 1:</p>	Is the resistance less than 1 Ω?	Go to step 9.	Repair open circuit in harness between ECM and intake air temperature and pressure sensor connector.
9	<p>CHECK HARNESS BETWEEN ECM AND INTAKE AIR TEMPERATURE AND PRESSURE SENSOR CONNECTOR. Measure resistance of harness between intake air temperature and pressure sensor connector and engine ground.</p> <p>Connector & terminal (E21) No. 4 — Engine ground:</p>	Is the resistance more than 500 kΩ?	Go to step 10.	Repair ground short circuit in harness between ECM and intake air temperature and pressure sensor connector.
10	<p>CHECK POOR CONTACT. Check poor contact in intake manifold pressure sensor connector.</p>	Is there poor contact in intake manifold pressure sensor connector?	Repair poor contact in intake air temperature and pressure sensor connector.	Replace intake air temperature and pressure sensor. <Ref. to FU-38, Intake Air Temperature and Pressure Sensor.>

MEMO:

DIAGNOSTIC PROCEDURE WITH DIAGNOSTIC TROUBLE CODE (DTC)

Engine (Diagnostics)

J: DTC P0108 — PRESSURE SENSOR CIRCUIT HIGH INPUT — S078521B13

- DTC DETECTING CONDITION:
 - Immediately at fault recognition

CAUTION:

After repair or replacement of faulty parts, conduct Clear Memory Mode <Ref. to EN-55, OPERATION, Clear Memory Mode.> and Inspection Mode <Ref. to EN-48, OPERATION, Inspection Mode.>.

- WIRING DIAGRAM:

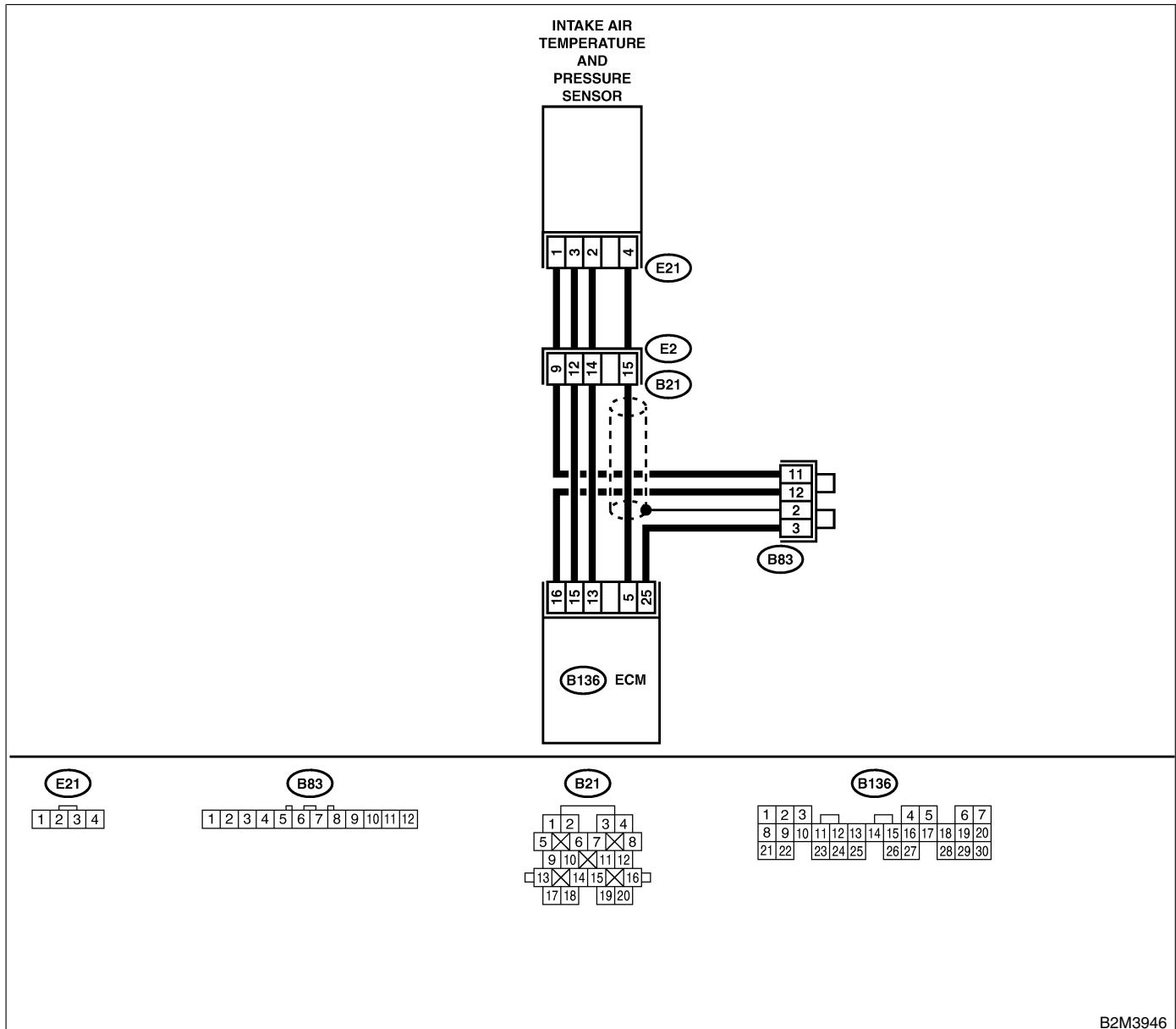

B2M3946

DIAGNOSTIC PROCEDURE WITH DIAGNOSTIC TROUBLE CODE (DTC)

Engine (Diagnostics)

No.	Step	Check	Yes	No
1	<p>CHECK CURRENT DATA. 1) Start engine. 2) Read the data of intake manifold absolute pressure signal using Subaru Select Monitor or OBD-II general scan tool. NOTE: ● Subaru Select Monitor For detailed operation procedure, refer to the "READ CURRENT DATA FOR ENGINE". <Ref. to EN-36, Subaru Select Monitor.> ● OBD-II general scan tool For detailed operation procedures, refer to the OBD-II General Scan Tool Instruction Manual.</p>	Is the value more than 119.5 kPa (896.5 mmHg, 35.29 inHg)?	Go to step 10.	Go to step 2.
2	<p>CHECK INPUT SIGNAL FOR ECM. Measure voltage between ECM connector and chassis ground. Connector & terminal (B136) No. 15 (+) — Chassis ground (-):</p>	Is the voltage more than 4.5 V?	Go to step 4.	Go to step 3.
3	<p>CHECK INPUT SIGNAL FOR ECM. Measure voltage between ECM connector and chassis ground. Connector & terminal (B136) No. 15 (+) — Chassis ground (-):</p>	Does the voltage change more than 4.5 V by shaking harness and connector of ECM while monitoring the value with voltage meter?	Repair poor contact in ECM connector.	Contact with SOA (distributor) service. NOTE: Inspection by DTM is required, because probable cause is deterioration of multiple parts.
4	<p>CHECK INPUT SIGNAL FOR ECM. Measure voltage between ECM connector and chassis ground. Connector & terminal (B136) No. 5 (+) — Chassis ground (-):</p>	Is the voltage less than 0.2 V?	Go to step 6.	Go to step 5.
5	<p>CHECK INPUT SIGNAL FOR ECM. (USING SUBARU SELECT MONITOR.) Read data of atmospheric absolute pressure signal using Subaru Select Monitor. NOTE: ● Subaru Select Monitor For detailed operation procedure, refer to the "READ CURRENT DATA FOR ENGINE". <Ref. to EN-36, Subaru Select Monitor.></p>	Does the value change more than 13.3 kPa (100 mmHg, 3.94 inHg) by shaking harness and connector of ECM while monitoring the value with Subaru Select Monitor?	Repair poor contact in ECM connector.	Go to step 6.
6	<p>CHECK HARNESS BETWEEN ECM AND INTAKE AIR TEMPERATURE AND PRESSURE SENSOR CONNECTOR. 1) Turn ignition switch to OFF. 2) Disconnect connector from intake air temperature and pressure sensor. 3) Turn ignition switch to ON. 4) Measure voltage between intake air temperature and pressure sensor connector and engine ground. Connector & terminal (E21) No. 3 (+) — Engine ground (-):</p>	Is the voltage more than 4.5 V?	Go to step 7.	Repair open circuit in harness between ECM and intake air temperature and pressure sensor connector.

DIAGNOSTIC PROCEDURE WITH DIAGNOSTIC TROUBLE CODE (DTC)

Engine (Diagnostics)

No.	Step	Check	Yes	No
7	<p>CHECK HARNESS BETWEEN ECM AND INTAKE AIR TEMPERATURE AND PRESSURE SENSOR CONNECTOR.</p> <p>1) Turn ignition switch to OFF. 2) Disconnect connector from ECM. 3) Measure resistance of harness between ECM and intake air temperature and pressure sensor connector.</p> <p>Connector & terminal (B136) No. 5 — (E21) No. 4:</p>	Is the resistance less than 1 Ω?	Go to step 8.	Repair open circuit in harness between ECM and intake air temperature and pressure sensor connector.
8	<p>CHECK HARNESS BETWEEN ECM AND INTAKE AIR TEMPERATURE AND PRESSURE SENSOR CONNECTOR.</p> <p>Measure resistance of harness between ECM and intake air temperature and pressure sensor connector.</p> <p>Connector & terminal (B136) No. 16 — (E21) No. 1:</p>	Is the resistance less than 1 Ω?	Go to step 9.	Repair open circuit in harness between ECM and intake air temperature and pressure sensor connector.
9	<p>CHECK POOR CONTACT.</p> <p>Check poor contact in intake air temperature and pressure sensor connector.</p>	Is there poor contact in intake manifold pressure sensor connector?	Repair poor contact in intake air temperature and pressure sensor connector.	Replace intake air temperature and pressure sensor. <Ref. to FU-38, Intake Air Temperature and Pressure Sensor.>
10	<p>CHECK HARNESS BETWEEN ECM AND INTAKE AIR TEMPERATURE AND PRESSURE SENSOR CONNECTOR.</p> <p>1) Turn ignition switch to OFF and Subaru Select Monitor or the OBD-II general scan tool switch to OFF. 2) Disconnect connector from intake air temperature and pressure sensor. 3) Turn ignition switch to ON and Subaru Select Monitor or the OBD-II general scan tool switch to ON. 4) Read data of intake manifold absolute pressure signal using Subaru Select Monitor or OBD-II general scan tool.</p> <p>NOTE:</p> <ul style="list-style-type: none"> ● Subaru Select Monitor For detailed operation procedure, refer to the "READ CURRENT DATA FOR ENGINE". <Ref. to EN-36, Subaru Select Monitor.> ● OBD-II general scan tool For detailed operation procedures, refer to the OBD-II General Scan Tool Instruction Manual. 	Is the value more than 119.5 kPa (896.5 mmHg, 35.29 inHg)?	Repair battery short circuit in harness between ECM and intake air temperature and pressure sensor connector.	Replace intake air temperature and pressure sensor. <Ref. to FU-38, Intake Air Temperature and Pressure Sensor.>

MEMO:

DIAGNOSTIC PROCEDURE WITH DIAGNOSTIC TROUBLE CODE (DTC)

Engine (Diagnostics)

K: DTC P0111 — INTAKE AIR TEMPERATURE SENSOR CIRCUIT RANGE/ PERFORMANCE PROBLEM — S078521B14

- **DTC DETECTING CONDITION:**
 - Two consecutive driving cycles with fault
- **TROUBLE SYMPTOM:**
 - Erroneous idling
 - Poor driving performance

CAUTION:

After repair or replacement of faulty parts, conduct Clear Memory Mode <Ref. to EN-55, OPERATION, Clear Memory Mode.> and Inspection Mode <Ref. to EN-48, OPERATION, Inspection Mode.>.

- **WIRING DIAGRAM:**

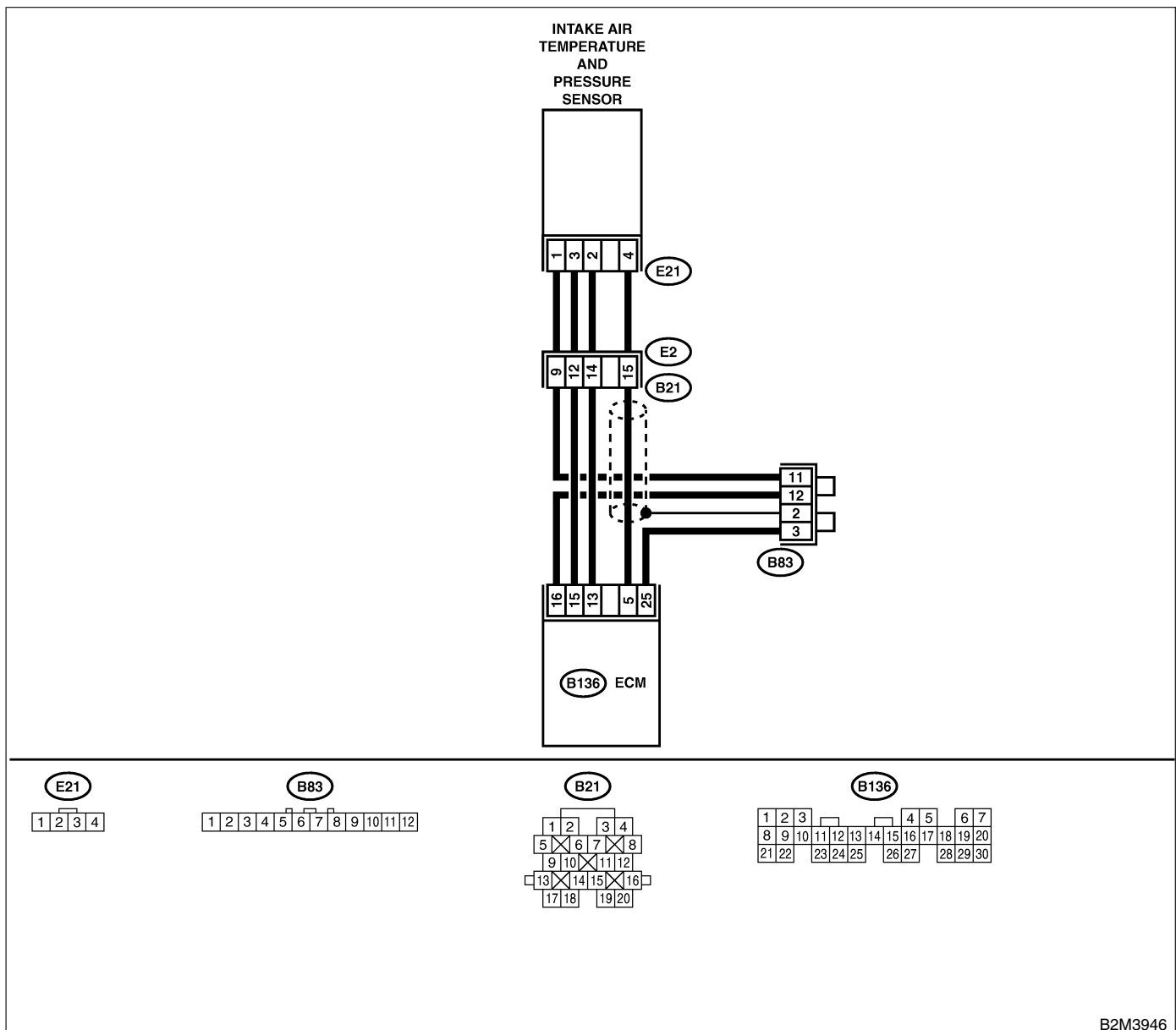

B2M3946

DIAGNOSTIC PROCEDURE WITH DIAGNOSTIC TROUBLE CODE (DTC)

Engine (Diagnostics)

No.	Step	Check	Yes	No
1	<p>CHECK ANY OTHER DTC ON DISPLAY.</p>	<p>Is any other DTC displayed?</p>	<p>Inspect the relevant DTC using "List of Diagnostic Trouble Code (DTC)". <Ref. to EN-88, List of Diagnostic Trouble Code (DTC).> NOTE: In this case, it is not necessary to inspect DTC P0111.</p>	<p>Go to step 2.</p>
2	<p>CHECK ENGINE COOLANT TEMPERATURE. 1) Start the engine and warm it up completely. 2) Measure engine coolant temperature using Subaru Select Monitor or OBD-II general scan tool. NOTE: ● Subaru Select Monitor For detailed operation procedure, refer to the "READ CURRENT DATA FOR ENGINE". <Ref. to EN-36, Subaru Select Monitor.> ● OBD-II general scan tool For detailed operation procedures, refer to the OBD-II General Scan Tool Instruction Manual.</p>	<p>Is the engine coolant temperature between 75°C (167°F) and 95°C (203°F)?</p>	<p>Replace intake air temperature and pressure sensor. <Ref. to FU-38, Intake Air Temperature and Pressure Sensor.></p>	<p>Inspect DTC P0125 using "List of Diagnostic Trouble Code (DTC)". <Ref. to EN-88, List of Diagnostic Trouble Code (DTC).></p>

DIAGNOSTIC PROCEDURE WITH DIAGNOSTIC TROUBLE CODE (DTC)

Engine (Diagnostics)

L: DTC P0112 — INTAKE AIR TEMPERATURE SENSOR CIRCUIT LOW INPUT

S078521B15

- **DTC DETECTING CONDITION:**
 - Immediately at fault recognition
- **TROUBLE SYMPTOM:**
 - Erroneous idling
 - Poor driving performance

CAUTION:

After repair or replacement of faulty parts, conduct Clear Memory Mode <Ref. to EN-55, OPERATION, Clear Memory Mode.> and Inspection Mode <Ref. to EN-48, OPERATION, Inspection Mode.>.

- **WIRING DIAGRAM:**

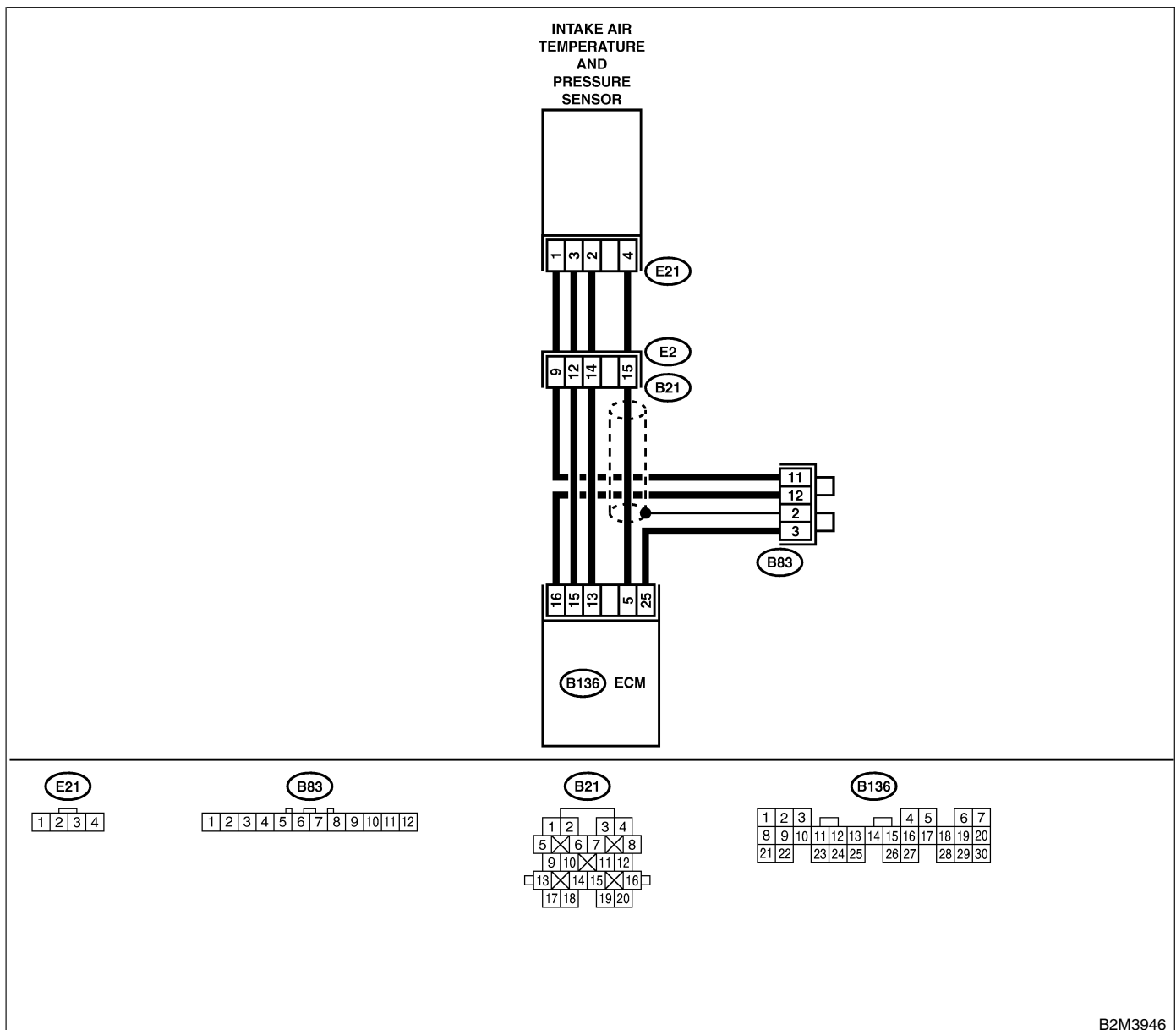

B2M3946

DIAGNOSTIC PROCEDURE WITH DIAGNOSTIC TROUBLE CODE (DTC)

Engine (Diagnostics)

No.	Step	Check	Yes	No
1	<p>CHECK CURRENT DATA.</p> <p>1) Start engine.</p> <p>2) Read data of intake air temperature sensor signal using Subaru Select Monitor or the OBD-II general scan tool.</p> <p>NOTE:</p> <ul style="list-style-type: none"> ● Subaru Select Monitor <p>For detailed operation procedure, refer to the "READ CURRENT DATA FOR ENGINE". <Ref. to EN-36, Subaru Select Monitor.></p> <ul style="list-style-type: none"> ● OBD-II general scan tool <p>For detailed operation procedure, refer to the OBD-II General Scan Tool Instruction Manual.</p>	<p>Is the value greater than 120°C (248°F)?</p>	<p>Go to step 2.</p>	<p>Repair poor contact.</p> <p>NOTE:</p> <p>In this case, repair the following:</p> <ul style="list-style-type: none"> ● Poor contact in intake air temperature and pressure sensor ● Poor contact in ECM ● Poor contact in coupling connector ● Poor contact in joint connector
2	<p>CHECK HARNESS BETWEEN INTAKE AIR TEMPERATURE AND PRESSURE SENSOR AND ECM CONNECTOR.</p> <p>1) Turn ignition switch to OFF.</p> <p>2) Disconnect connector from intake air temperature and pressure sensor.</p> <p>3) Turn ignition switch to ON.</p> <p>4) Read data of intake air temperature sensor signal using Subaru Select Monitor or the OBD-II general scan tool.</p> <p>NOTE:</p> <ul style="list-style-type: none"> ● Subaru Select Monitor <p>For detailed operation procedure, refer to the "READ CURRENT DATA FOR ENGINE". <Ref. to EN-36, Subaru Select Monitor.></p> <ul style="list-style-type: none"> ● OBD-II general scan tool <p>For detailed operation procedure, refer to the OBD-II General Scan Tool Instruction Manual.</p>	<p>Is the value less than -40°C (-40°F)?</p>	<p>Replace intake air temperature and pressure sensor. <Ref. to FU-38, Intake Air Temperature and Pressure Sensor.></p>	<p>Repair ground short circuit in harness between intake air temperature sensor and ECM connector.</p>

DIAGNOSTIC PROCEDURE WITH DIAGNOSTIC TROUBLE CODE (DTC)

Engine (Diagnostics)

M: DTC P0113 — INTAKE AIR TEMPERATURE SENSOR CIRCUIT HIGH INPUT — S078521B16

- **DTC DETECTING CONDITION:**
 - Immediately at fault recognition
- **TROUBLE SYMPTOM:**
 - Erroneous idling
 - Poor driving performance

CAUTION:

After repair or replacement of faulty parts, conduct Clear Memory Mode <Ref. to EN-55, OPERATION, Clear Memory Mode.> and Inspection Mode <Ref. to EN-48, OPERATION, Inspection Mode.>.

- **WIRING DIAGRAM:**

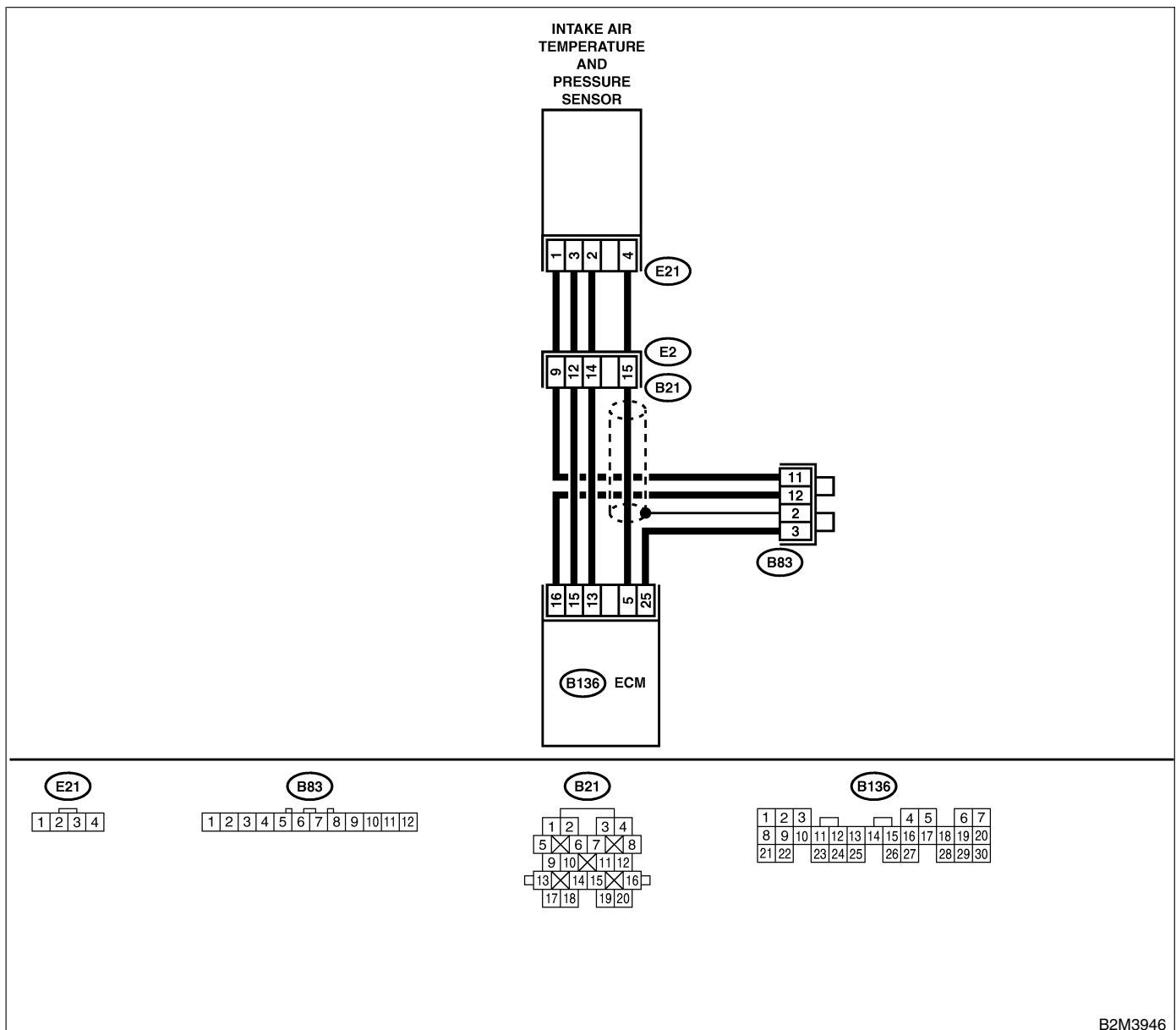

B2M3946

DIAGNOSTIC PROCEDURE WITH DIAGNOSTIC TROUBLE CODE (DTC)

Engine (Diagnostics)

No.	Step	Check	Yes	No
1	<p>CHECK CURRENT DATA.</p> <p>1) Start engine. 2) Read data of intake air temperature sensor signal using Subaru Select Monitor or the OBD-II general scan tool.</p> <p>NOTE:</p> <ul style="list-style-type: none"> ● Subaru Select Monitor <p>For detailed operation procedure, refer to the "READ CURRENT DATA FOR ENGINE". <Ref. to EN-36, Subaru Select Monitor.></p> <ul style="list-style-type: none"> ● OBD-II general scan tool <p>For detailed operation procedure, refer to the OBD-II General Scan Tool Instruction Manual.</p>	Is the value less than -40°C (-40°F)?	Go to step 2.	<p>Repair poor contact.</p> <p>NOTE:</p> <p>In this case, repair the following:</p> <ul style="list-style-type: none"> ● Poor contact in intake air temperature and pressure sensor ● Poor contact in ECM ● Poor contact in coupling connector ● Poor contact in joint connector
2	<p>CHECK HARNESS BETWEEN INTAKE AIR TEMPERATURE AND PRESSURE SENSOR AND ECM CONNECTOR.</p> <p>1) Turn ignition switch to OFF. 2) Disconnect connector from intake air temperature and pressure sensor. 3) Measure voltage between intake air temperature and pressure sensor connector and engine ground.</p> <p>Connector & terminal (E21) No. 2 (+) — Engine ground (-):</p>	Is the voltage more than 10 V?	Repair battery short circuit in harness between intake air temperature and pressure sensor and ECM connector.	Go to step 3.
3	<p>CHECK HARNESS BETWEEN INTAKE AIR TEMPERATURE AND PRESSURE SENSOR AND ECM CONNECTOR.</p> <p>1) Turn ignition switch to ON. 2) Measure voltage between intake air temperature and pressure sensor connector and engine ground.</p> <p>Connector & terminal (E21) No. 2 (+) — Engine ground (-):</p>	Is the voltage more than 10 V?	Repair battery short circuit in harness between intake air temperature and pressure sensor and ECM connector.	Go to step 4.

DIAGNOSTIC PROCEDURE WITH DIAGNOSTIC TROUBLE CODE (DTC)

Engine (Diagnostics)

No.	Step	Check	Yes	No
4	<p>CHECK HARNESS BETWEEN INTAKE AIR TEMPERATURE AND PRESSURE SENSOR AND ECM CONNECTOR. Measure voltage between intake air temperature and pressure sensor connector and engine ground. Connector & terminal (E21) No. 2 (+) — Engine ground (-):</p>	Is the voltage more than 3 V?	Go to step 5.	Repair harness and connector. NOTE: In this case, repair the following: <ul style="list-style-type: none"> ● Open circuit in harness between intake air temperature and pressure sensor and ECM connector ● Poor contact in intake air temperature and pressure sensor ● Poor contact in ECM ● Poor contact in coupling connector ● Poor contact in joint connector
5	<p>CHECK HARNESS BETWEEN INTAKE AIR TEMPERATURE AND PRESSURE SENSOR AND ECM CONNECTOR. 1) Turn ignition switch to OFF. 2) Measure resistance of harness between intake air temperature and pressure sensor connector and engine ground. Connector & terminal (E21) No. 1 — Engine ground:</p>	Is the resistance less than 5 Ω?	Replace intake air temperature and pressure sensor. <Ref. to FU-38, Intake Air Temperature and Pressure Sensor.>	Repair harness and connector. NOTE: In this case, repair the following: <ul style="list-style-type: none"> ● Open circuit in harness between intake air temperature and pressure sensor and ECM connector ● Poor contact in intake air temperature and pressure sensor ● Poor contact in ECM ● Poor contact in coupling connector ● Poor contact in joint connector

MEMO:

DIAGNOSTIC PROCEDURE WITH DIAGNOSTIC TROUBLE CODE (DTC)

Engine (Diagnostics)

N: DTC P0117 — ENGINE COOLANT TEMPERATURE SENSOR CIRCUIT LOW INPUT — S078521F91

- **DTC DETECTING CONDITION:**
 - Immediately at fault recognition
- **TROUBLE SYMPTOM:**
 - Hard to start
 - Erroneous idling
 - Poor driving performance

CAUTION:

After repair or replacement of faulty parts, conduct Clear Memory Mode <Ref. to EN-55, OPERATION, Clear Memory Mode.> and Inspection Mode <Ref. to EN-48, OPERATION, Inspection Mode.>.

- **WIRING DIAGRAM:**

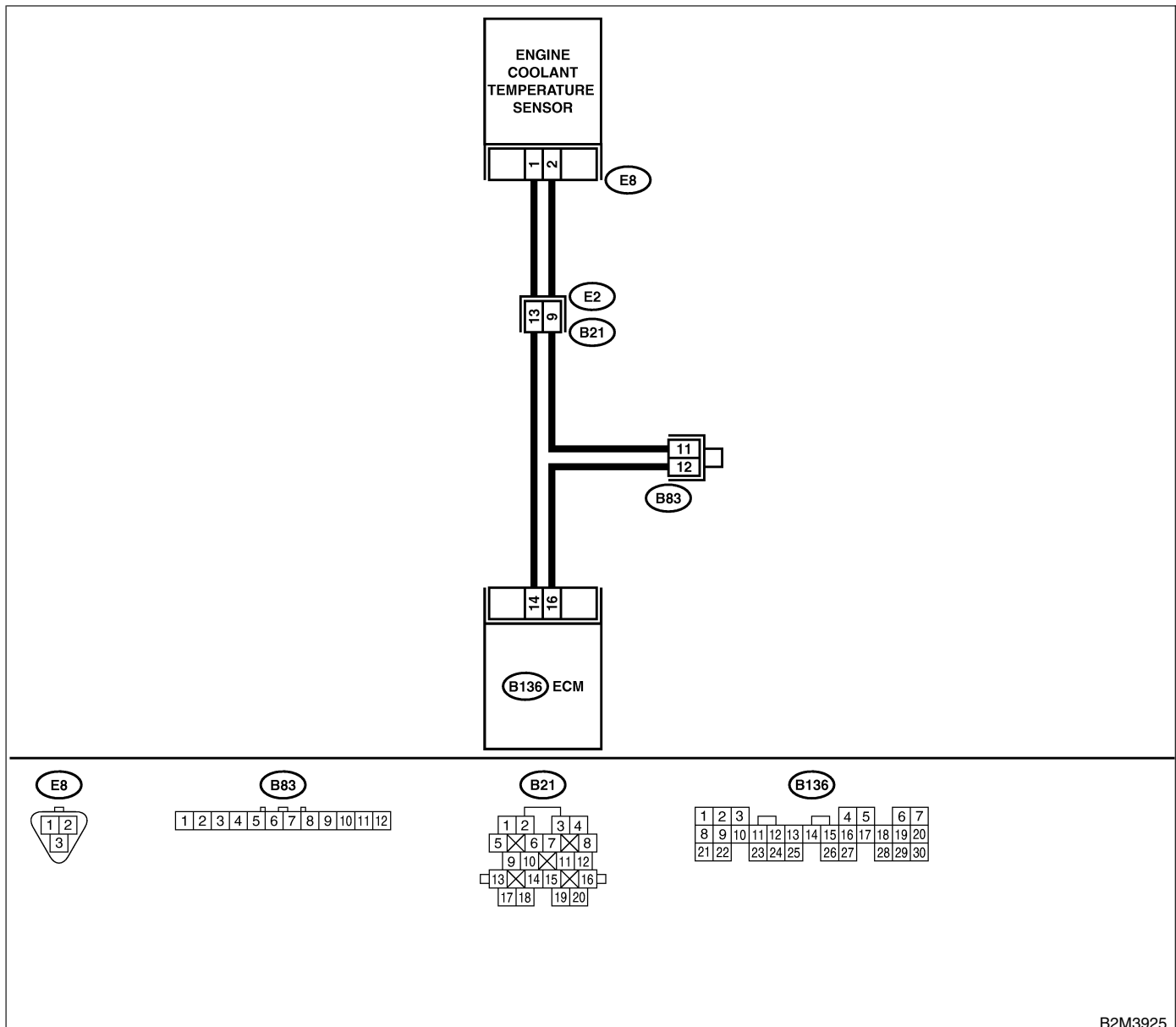

B2M3925

DIAGNOSTIC PROCEDURE WITH DIAGNOSTIC TROUBLE CODE (DTC)

Engine (Diagnostics)

No.	Step	Check	Yes	No
1	<p>CHECK CURRENT DATA.</p> <p>1) Start engine.</p> <p>2) Read data of engine coolant temperature sensor signal using Subaru Select Monitor or OBD-II general scan tool.</p> <p>NOTE:</p> <ul style="list-style-type: none"> ● Subaru Select Monitor <p>For detailed operation procedure, refer to the "READ CURRENT DATA FOR ENGINE". <Ref. to EN-36, Subaru Select Monitor.></p> <ul style="list-style-type: none"> ● OBD-II general scan tool <p>For detailed operation procedures, refer to the OBD-II General Scan Tool Instruction Manual.</p>	<p>Is the value greater than 120°C (248°F)?</p>	<p>Go to step 2.</p>	<p>Repair poor contact.</p> <p>NOTE:</p> <p>In this case, repair the following:</p> <ul style="list-style-type: none"> ● Poor contact in engine coolant temperature sensor ● Poor contact in ECM ● Poor contact in coupling connector ● Poor contact in joint connector
2	<p>CHECK HARNESS BETWEEN ENGINE COOLANT TEMPERATURE SENSOR AND ECM CONNECTOR.</p> <p>1) Turn ignition switch to OFF.</p> <p>2) Disconnect connector from engine coolant temperature sensor.</p> <p>3) Turn ignition switch to ON.</p> <p>4) Read data of engine coolant temperature sensor signal using Subaru Select Monitor or OBD-II general scan tool.</p> <p>NOTE:</p> <ul style="list-style-type: none"> ● Subaru Select Monitor <p>For detailed operation procedure, refer to the "READ CURRENT DATA FOR ENGINE". <Ref. to EN-36, Subaru Select Monitor.></p> <ul style="list-style-type: none"> ● OBD-II general scan tool <p>For detailed operation procedures, refer to the OBD-II General Scan Tool Instruction Manual.</p>	<p>Is the value less than -40°C (-40°F)?</p>	<p>Replace engine coolant temperature sensor. <Ref. to FU-30, Engine Coolant Temperature Sensor.></p>	<p>Repair ground short circuit in harness between engine coolant temperature sensor and ECM connector.</p>

DIAGNOSTIC PROCEDURE WITH DIAGNOSTIC TROUBLE CODE (DTC)

Engine (Diagnostics)

O: DTC P0118 — ENGINE COOLANT TEMPERATURE SENSOR CIRCUIT HIGH INPUT —

S078521F92

- **DTC DETECTING CONDITION:**
 - Immediately at fault recognition
- **TROUBLE SYMPTOM:**
 - Hard to start
 - Erroneous idling
 - Poor driving performance

CAUTION:

After repair or replacement of faulty parts, conduct Clear Memory Mode <Ref. to EN-55, OPERATION, Clear Memory Mode.> and Inspection Mode <Ref. to EN-48, OPERATION, Inspection Mode.>.

● WIRING DIAGRAM:

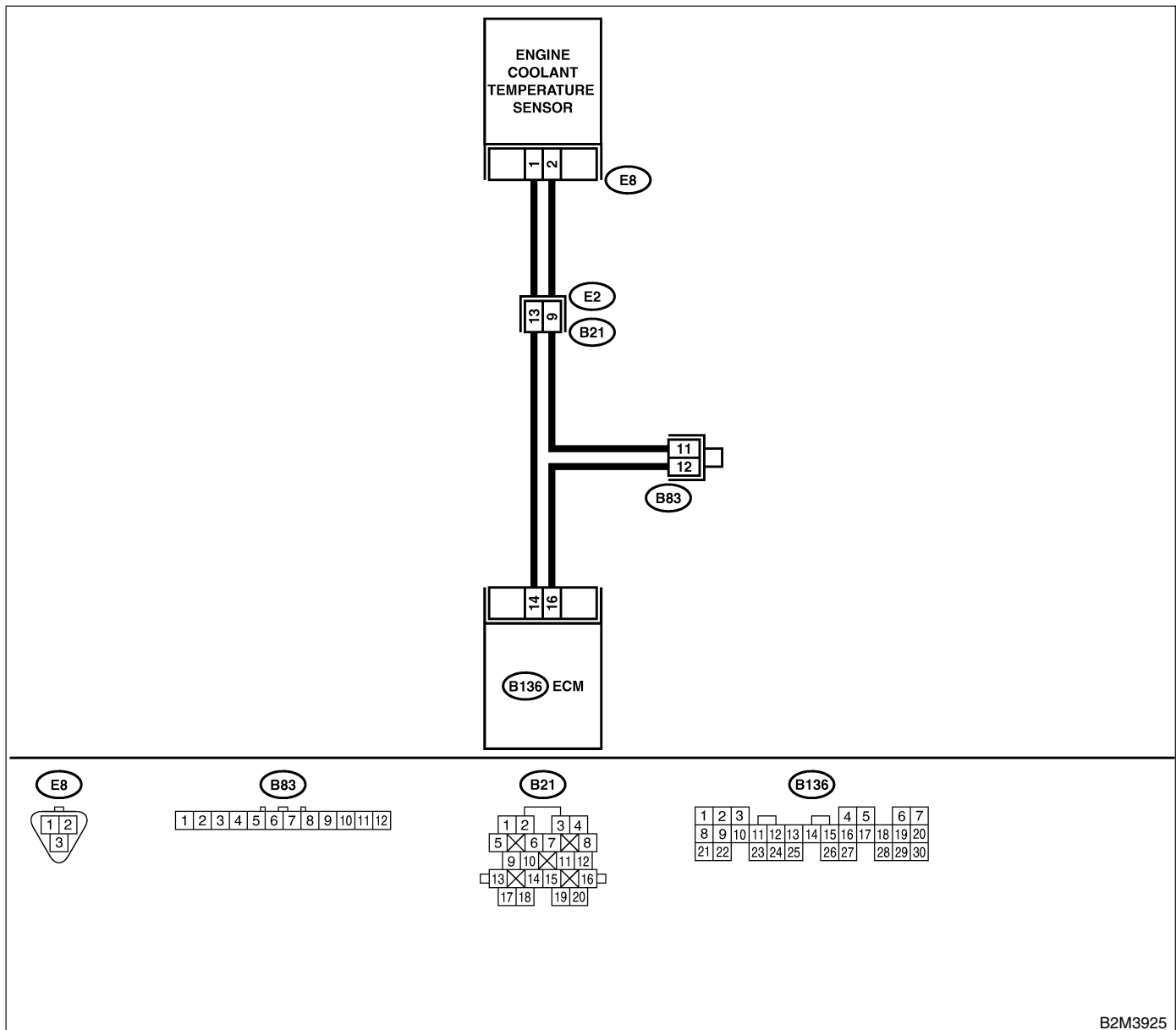

B2M3925

DIAGNOSTIC PROCEDURE WITH DIAGNOSTIC TROUBLE CODE (DTC)

Engine (Diagnostics)

No.	Step	Check	Yes	No
1	<p>CHECK CURRENT DATA.</p> <p>1) Start engine. 2) Read data of engine coolant temperature sensor signal using Subaru Select Monitor or OBD-II general scan tool.</p> <p>NOTE:</p> <ul style="list-style-type: none"> ● Subaru Select Monitor <p>For detailed operation procedure, refer to the "READ CURRENT DATA FOR ENGINE". <Ref. to EN-36, Subaru Select Monitor.></p> <ul style="list-style-type: none"> ● OBD-II general scan tool <p>For detailed operation procedures, refer to the OBD-II General Scan Tool Instruction Manual.</p>	Is the value less than -40°C (-40°F)?	Go to step 2.	<p>Repair poor contact.</p> <p>NOTE:</p> <p>In this case, repair the following:</p> <ul style="list-style-type: none"> ● Poor contact in engine coolant temperature sensor ● Poor contact in ECM ● Poor contact in coupling connector ● Poor contact in joint connector
2	<p>CHECK HARNESS BETWEEN ENGINE COOLANT TEMPERATURE SENSOR AND ECM CONNECTOR.</p> <p>1) Turn ignition switch to OFF. 2) Disconnect connector from engine coolant temperature sensor. 3) Measure voltage between engine coolant temperature sensor connector and engine ground.</p> <p>Connector & terminal (E8) No. 1 (+) — Engine ground (-):</p>	Is the voltage more than 10 V?	Repair battery short circuit in harness between ECM and engine coolant temperature sensor connector.	Go to step 3.
3	<p>CHECK HARNESS BETWEEN ENGINE COOLANT TEMPERATURE SENSOR AND ECM CONNECTOR.</p> <p>1) Turn ignition switch to ON. 2) Measure voltage between engine coolant temperature sensor connector and engine ground.</p> <p>Connector & terminal (E8) No. 1 (+) — Engine ground (-):</p>	Is the voltage more than 10 V?	Repair battery short circuit in harness between ECM and engine coolant temperature sensor connector.	Go to step 4.
4	<p>CHECK HARNESS BETWEEN ENGINE COOLANT TEMPERATURE SENSOR AND ECM CONNECTOR.</p> <p>Measure voltage between engine coolant temperature sensor connector and engine ground.</p> <p>Connector & terminal (E8) No. 1 (+) — Engine ground (-):</p>	Is the voltage more than 4 V?	Go to step 5.	<p>Repair harness and connector.</p> <p>NOTE:</p> <p>In this case, repair the following:</p> <ul style="list-style-type: none"> ● Open circuit in harness between ECM and engine coolant temperature sensor connector ● Poor contact in engine coolant temperature sensor connector ● Poor contact in ECM connector ● Poor contact in coupling connector ● Poor contact in joint connector

DIAGNOSTIC PROCEDURE WITH DIAGNOSTIC TROUBLE CODE (DTC)

Engine (Diagnostics)

No.	Step	Check	Yes	No
5	<p>CHECK HARNESS BETWEEN ENGINE COOLANT TEMPERATURE SENSOR AND ECM CONNECTOR.</p> <p>1) Turn ignition switch to OFF. 2) Measure resistance of harness between engine coolant temperature sensor connector and engine ground.</p> <p>Connector & terminal (E8) No. 2 — Engine ground:</p>	Is the resistance less than 5 Ω ?	Replace engine coolant temperature sensor. <Ref. to FU-30, Engine Coolant Temperature Sensor.>	Repair harness and connector. NOTE: In this case, repair the following: <ul style="list-style-type: none">● Open circuit in harness between ECM and engine coolant temperature sensor connector● Poor contact in engine coolant temperature sensor connector● Poor contact in ECM connector● Poor contact in coupling connector● Poor contact in joint connector

MEMO:

DIAGNOSTIC PROCEDURE WITH DIAGNOSTIC TROUBLE CODE (DTC)

Engine (Diagnostics)

P: DTC P0121 — THROTTLE POSITION SENSOR CIRCUIT RANGE/PERFORMANCE PROBLEM (HIGH INPUT) — S078521B19

● DTC DETECTING CONDITION:

- Two consecutive driving cycles with fault

● TROUBLE SYMPTOM:

- Erroneous idling
- Engine stalls.
- Poor driving performance

CAUTION:

After repair or replacement of faulty parts, conduct Clear Memory Mode <Ref. to EN-55, OPERATION, Clear Memory Mode.> and Inspection Mode <Ref. to EN-48, OPERATION, Inspection Mode.>.

● WIRING DIAGRAM:

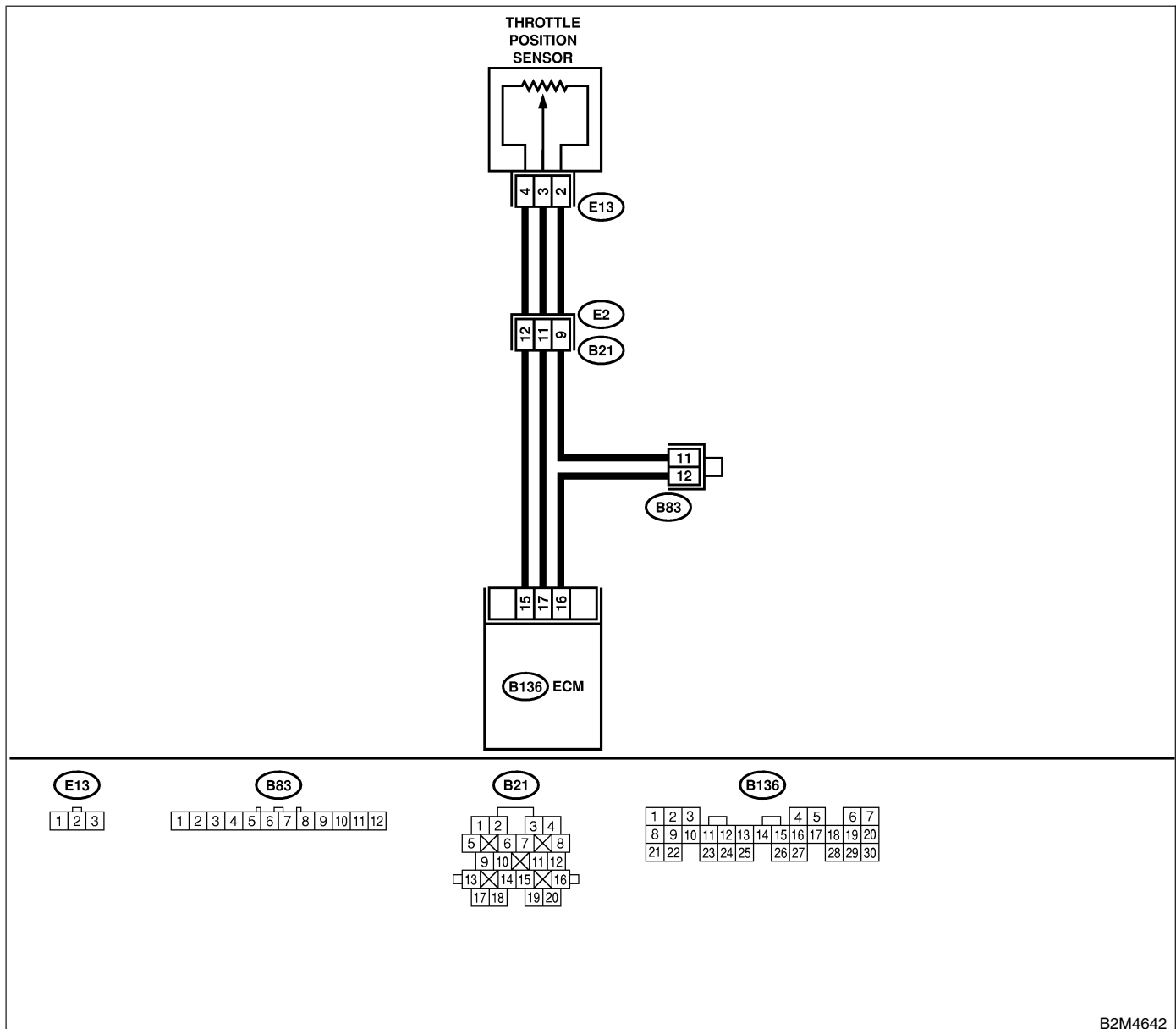

B2M4642

DIAGNOSTIC PROCEDURE WITH DIAGNOSTIC TROUBLE CODE (DTC)

Engine (Diagnostics)

No.	Step	Check	Yes	No
1	CHECK ANY OTHER DTC ON DISPLAY.	Is any other DTC displayed?	Inspect the relevant DTC using "List of Diagnostic Trouble Code (DTC)". <Ref. to EN-88, List of Diagnostic Trouble Code (DTC).> NOTE: In this case, it is not necessary to inspect DTC P0121.	Replace throttle position sensor. <Ref. to FU-35, Throttle Position Sensor.>

DIAGNOSTIC PROCEDURE WITH DIAGNOSTIC TROUBLE CODE (DTC)

Engine (Diagnostics)

Q: DTC P0122 — THROTTLE POSITION SENSOR CIRCUIT LOW INPUT —

S078521B20

- **DTC DETECTING CONDITION:**
 - Immediately at fault recognition
- **TROUBLE SYMPTOM:**
 - Erroneous idling
 - Engine stalls.
 - Poor driving performance

CAUTION:

After repair or replacement of faulty parts, conduct Clear Memory Mode <Ref. to EN-55, OPERATION, Clear Memory Mode.> and Inspection Mode <Ref. to EN-48, OPERATION, Inspection Mode.>.

● WIRING DIAGRAM:

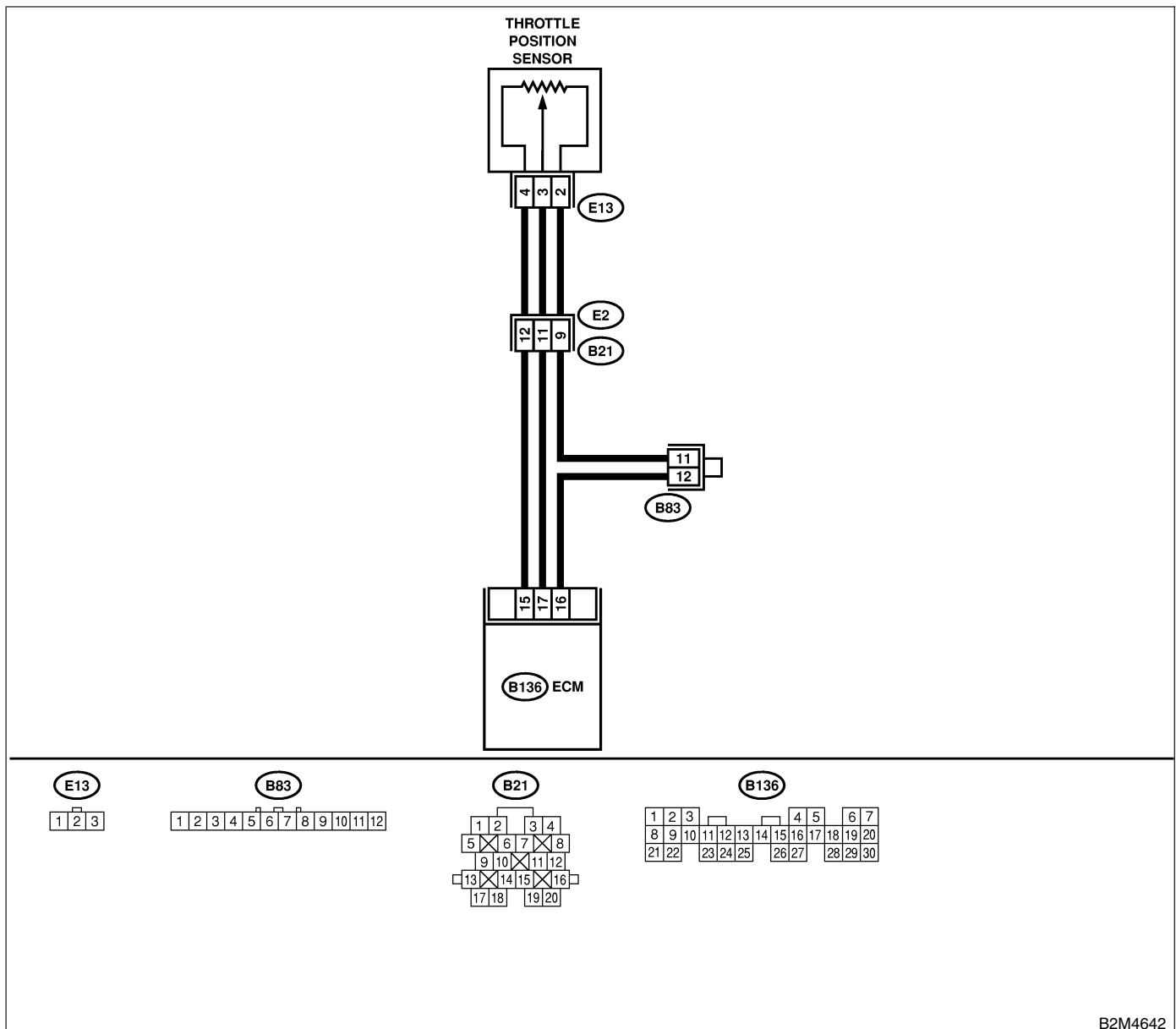

B2M4642

DIAGNOSTIC PROCEDURE WITH DIAGNOSTIC TROUBLE CODE (DTC)

Engine (Diagnostics)

No.	Step	Check	Yes	No
1	<p>CHECK CURRENT DATA.</p> <p>1) Start engine. 2) Read data of throttle position sensor signal using Subaru Select Monitor or OBD-II general scan tool.</p> <p>NOTE:</p> <ul style="list-style-type: none"> Subaru Select Monitor <p>For detailed operation procedure, refer to the "READ CURRENT DATA FOR ENGINE". <Ref. to EN-36, Subaru Select Monitor.></p> <ul style="list-style-type: none"> OBD-II general scan tool <p>For detailed operation procedures, refer to the OBD-II General Scan Tool Instruction Manual.</p>	Is the value less than 0.1 V?	Go to step 2.	Even if MIL lights up, the circuit has returned to a normal condition at this time. A temporary poor contact of the connector may be the cause. NOTE: In this case, repair the following: <ul style="list-style-type: none"> Poor contact in throttle position sensor connector Poor contact in ECM connector Poor contact in coupling connector
2	<p>CHECK INPUT SIGNAL FOR ECM.</p> <p>Measure voltage between ECM connector and chassis ground while throttle valve is fully closed.</p> <p>Connector & terminal (B136) No. 15 (+) — Chassis ground (-):</p>	Is the voltage more than 4.5 V?	Go to step 4.	Go to step 3.
3	<p>CHECK INPUT SIGNAL FOR ECM.</p> <p>Measure voltage between ECM connector and chassis ground.</p> <p>Connector & terminal (B136) No. 15 (+) — Chassis ground (-):</p>	Does the voltage change more than 4.5 V by shaking harness and connector of ECM while monitoring the value with voltage meter?	Repair poor contact in ECM connector.	Contact with SOA (distributor) service. NOTE: Inspection by DTM is required, because probable cause is deterioration of multiple parts.
4	<p>CHECK INPUT SIGNAL FOR ECM.</p> <p>Measure voltage between ECM connector and chassis ground.</p> <p>Connector & terminal (B136) No. 17 (+) — Chassis ground (-):</p>	Is the voltage less than 0.1 V?	Go to step 6.	Go to step 5.
5	<p>CHECK INPUT SIGNAL FOR ECM. (USING SUBARU SELECT MONITOR.)</p> <p>Measure voltage between ECM connector and chassis ground.</p>	Does the voltage change more than 0.1 V by shaking harness and connector of ECM while monitoring the value with Subaru Select Monitor?	Repair poor contact in ECM connector.	Go to step 6.

DIAGNOSTIC PROCEDURE WITH DIAGNOSTIC TROUBLE CODE (DTC)

Engine (Diagnostics)

No.	Step	Check	Yes	No
6	<p>CHECK HARNESS BETWEEN ECM AND THROTTLE POSITION SENSOR CONNECTOR.</p> <p>1) Turn ignition switch to OFF. 2) Disconnect connectors from throttle position sensor. 3) Turn ignition switch to ON. 4) Measure voltage between throttle position sensor connector and engine ground.</p> <p>Connector & terminal (E13) No. 4 (+) — Engine ground (-):</p>	Is the voltage more than 4.5 V?	Go to step 7.	<p>Repair harness and connector.</p> <p>NOTE: In this case, repair the following:</p> <ul style="list-style-type: none"> ● Open circuit in harness between throttle position sensor and ECM connector ● Poor contact in throttle position sensor connector ● Poor contact in ECM connector ● Poor contact in coupling connector ● Poor contact in joint connector
7	<p>CHECK HARNESS BETWEEN ECM AND THROTTLE POSITION SENSOR CONNECTOR.</p> <p>1) Turn ignition switch to OFF. 2) Measure resistance of harness between ECM connector and throttle position sensor connector.</p> <p>Connector & terminal (B136) No. 17 — (E13) No. 3:</p>	Is the resistance less than 1 Ω?	Go to step 8.	<p>Repair harness and connector.</p> <p>NOTE: In this case, repair the following:</p> <ul style="list-style-type: none"> ● Open circuit in harness between throttle position sensor and ECM connector ● Poor contact in ECM connector ● Poor contact in throttle position sensor connector ● Poor contact in coupling connector
8	<p>CHECK HARNESS BETWEEN ECM AND THROTTLE POSITION SENSOR CONNECTOR.</p> <p>Measure resistance of harness between throttle position sensor connector and engine ground.</p> <p>Connector & terminal (E13) No. 3 — Engine ground:</p>	Is the resistance more than 1 MΩ?	Go to step 9.	<p>Repair ground short circuit in harness between throttle position sensor and ECM connector.</p>
9	<p>CHECK POOR CONTACT.</p> <p>Check poor contact in throttle position sensor connector.</p>	Is there poor contact in throttle position sensor connector?	Repair poor contact in throttle position sensor connector.	<p>Replace throttle position sensor. <Ref. to FU-35, Throttle Position Sensor.></p>

MEMO:

DIAGNOSTIC PROCEDURE WITH DIAGNOSTIC TROUBLE CODE (DTC)

Engine (Diagnostics)

R: DTC P0123 — THROTTLE POSITION SENSOR CIRCUIT HIGH INPUT —

S078521B21

- **DTC DETECTING CONDITION:**
 - Immediately at fault recognition
- **TROUBLE SYMPTOM:**
 - Erroneous idling
 - Engine stalls.
 - Poor driving performance

CAUTION:

After repair or replacement of faulty parts, conduct Clear Memory Mode <Ref. to EN-55, OPERATION, Clear Memory Mode.> and Inspection Mode <Ref. to EN-48, OPERATION, Inspection Mode.>.

● WIRING DIAGRAM:

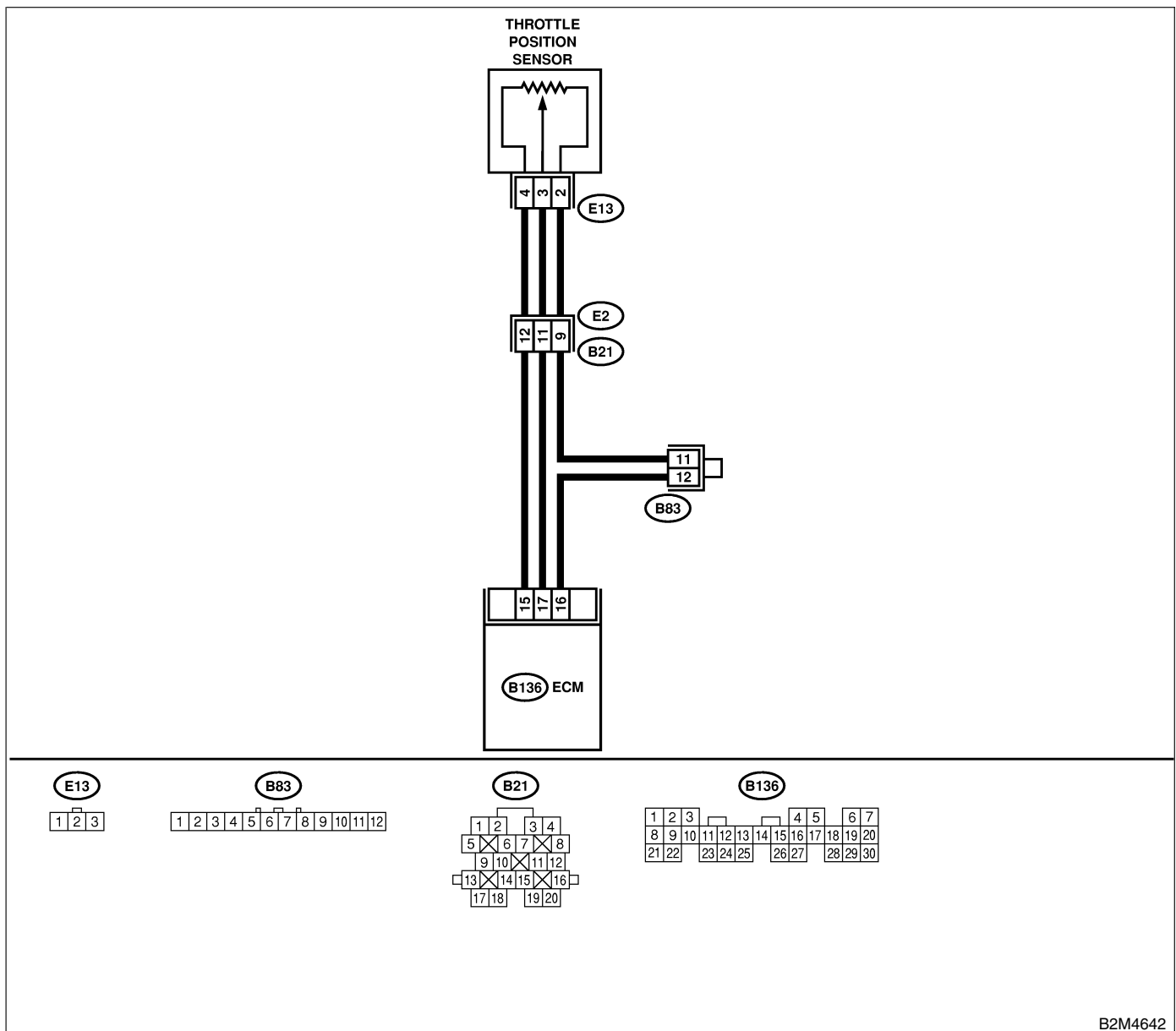

DIAGNOSTIC PROCEDURE WITH DIAGNOSTIC TROUBLE CODE (DTC)

Engine (Diagnostics)

No.	Step	Check	Yes	No
1	<p>CHECK CURRENT DATA.</p> <p>1) Start engine. 2) Read data of throttle position sensor signal using Subaru Select Monitor or OBD-II general scan tool.</p> <p>NOTE:</p> <ul style="list-style-type: none"> ● Subaru Select Monitor <p>For detailed operation procedure, refer to the "READ CURRENT DATA FOR ENGINE". <Ref. to EN-36, Subaru Select Monitor.></p> <ul style="list-style-type: none"> ● OBD-II general scan tool <p>For detailed operation procedures, refer to the OBD-II General Scan Tool Instruction Manual.</p>	Is the value more than 4.9 V?	Go to step 2.	<p>Even if MIL lights up, the circuit has returned to a normal condition at this time. A temporary poor contact of the connector may be the cause.</p> <p>NOTE:</p> <p>In this case, repair the following:</p> <ul style="list-style-type: none"> ● Poor contact in throttle position sensor connector ● Poor contact in ECM connector ● Poor contact in coupling connector
2	<p>CHECK HARNESS BETWEEN THROTTLE POSITION SENSOR AND ECM CONNECTOR.</p> <p>1) Turn ignition switch to OFF. 2) Disconnect connector from throttle position sensor. 3) Measure resistance of harness between throttle position sensor connector and engine ground.</p> <p>Connector & terminal (E13) No. 2 — Engine ground:</p>	Is the resistance less than 5 Ω?	Go to step 3.	<p>Repair harness and connector.</p> <p>NOTE:</p> <p>In this case, repair the following:</p> <ul style="list-style-type: none"> ● Open circuit in harness between throttle position sensor and ECM connector ● Poor contact in coupling connector ● Poor contact in joint connector
3	<p>CHECK HARNESS BETWEEN THROTTLE POSITION SENSOR AND ECM CONNECTOR.</p> <p>1) Turn ignition switch to ON. 2) Measure voltage between throttle position sensor connector and engine ground.</p> <p>Connector & terminal (E13) No. 3 (+) — Engine ground (-):</p>	Is the voltage more than 4.9 V?	Repair battery short circuit in harness between throttle position sensor and ECM connector. After repair, replace ECM. <Ref. to FU-51, Engine Control Module.>	<p>Replace throttle position sensor. <Ref. to FU-35, Throttle Position Sensor.></p>

DIAGNOSTIC PROCEDURE WITH DIAGNOSTIC TROUBLE CODE (DTC)

Engine (Diagnostics)

S: DTC P0125 — INSUFFICIENT COOLANT TEMPERATURE FOR CLOSED LOOP FUEL CONTROL — S078521B22

- **DTC DETECTING CONDITION:**
 - Two consecutive driving cycles with fault
- **TROUBLE SYMPTOM:**
 - Engine would not return to idling.

CAUTION:

After repair or replacement of faulty parts, conduct Clear Memory Mode <Ref. to EN-55, OPERATION, Clear Memory Mode.> and Inspection Mode <Ref. to EN-48, OPERATION, Inspection Mode.>.

● WIRING DIAGRAM:

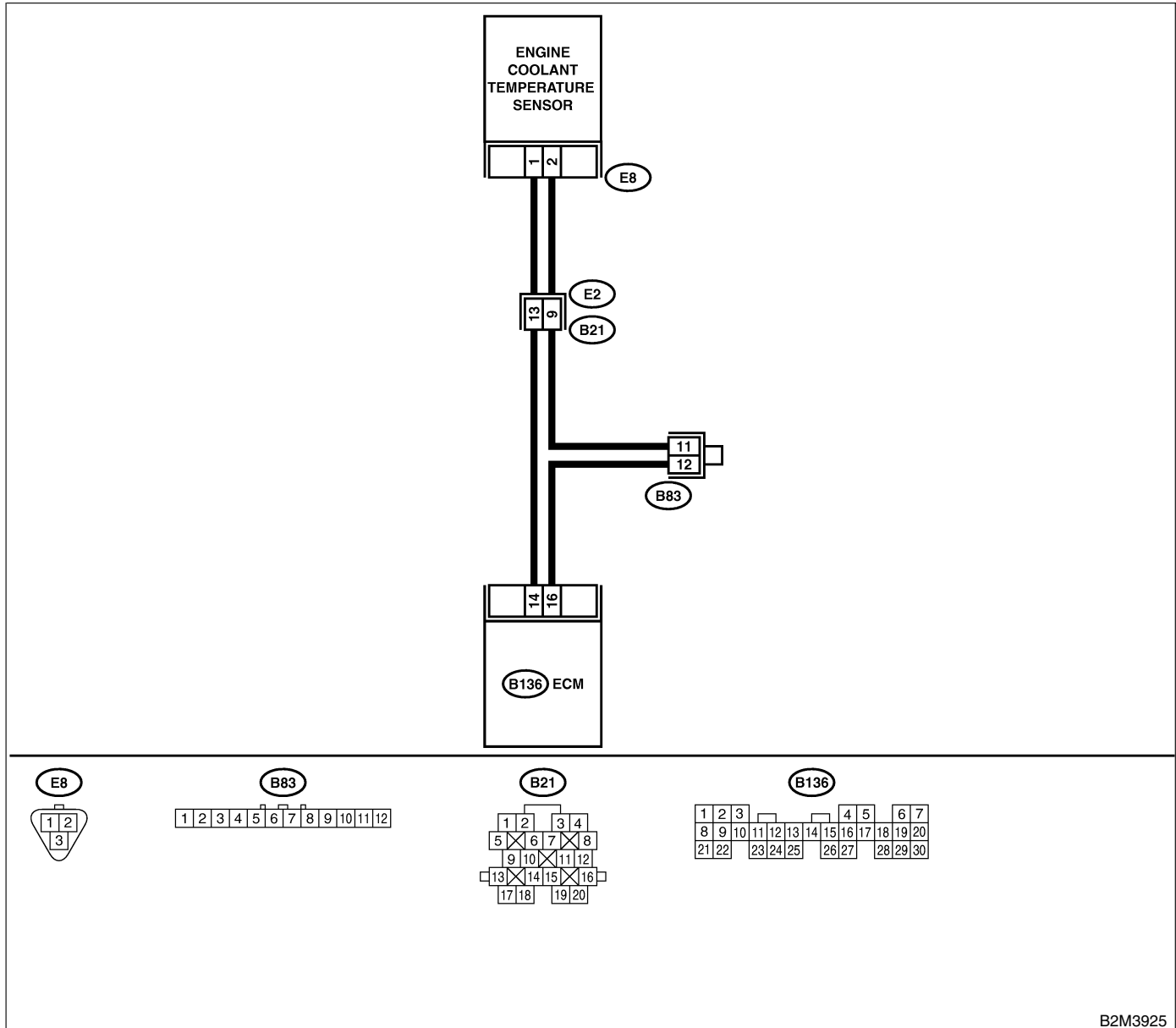

B2M3925

DIAGNOSTIC PROCEDURE WITH DIAGNOSTIC TROUBLE CODE (DTC)

Engine (Diagnostics)

No.	Step	Check	Yes	No
1	CHECK ANY OTHER DTC ON DISPLAY.	Is any other DTC displayed?	Inspect the relevant DTC using "List of Diagnostic Trouble Code (DTC)". <Ref. to EN-88, List of Diagnostic Trouble Code (DTC).> NOTE: In this case, it is not necessary to inspect DTC P0125.	Go to step 2.
2	CHECK THERMOSTAT.	Does thermostat remain opened?	Replace thermostat. <Ref. to CO-19, Thermostat.>	Replace engine coolant temperature sensor. <Ref. to EN-30, Engine Coolant Temperature Sensor.>

DIAGNOSTIC PROCEDURE WITH DIAGNOSTIC TROUBLE CODE (DTC)

Engine (Diagnostics)

T: DTC P0128 — THERMOSTAT MALFUNCTION — S078521F93

- **DTC DETECTING CONDITION:**
 - Two consecutive driving cycles with fault
- **TROUBLE SYMPTOM:**
 - Thermostat remains open.

CAUTION:

After repair or replacement of faulty parts, conduct Clear Memory Mode <Ref. to EN-55, OPERATION, Clear Memory Mode.> and Inspection Mode <Ref. to EN-48, OPERATION, Inspection Mode.>.

No.	Step	Check	Yes	No
1	CHECK VEHICLE CONDITION.	Has engine operated at idle or has vehicle been driven with part of engine submerged under water?	In this case, it is not necessary to inspect DTC P1490.	Go to step 2.
2	CHECK ANY OTHER DTC ON DISPLAY.	Is any other DTC displayed?	Go to step 3.	Inspect the relevant DTC using "List of Diagnostic Trouble Code (DTC)". <Ref. to EN-88, List of Diagnostic Trouble Code (DTC).>
3	CHECK TIRE SIZE.	Is the tire size the same as designated tire and four wheel tire?	Go to step 4.	Replace tire.
4	CHECK ENGINE COOLANT.	Are coolant level and mixture ratio of cooling water to anti-freeze solution correct?	Go to step 5.	Replace engine coolant. <Ref. to CO-12, REPLACEMENT, Engine Coolant.>
5	CHECK RADIATOR FAN. 1) Start the engine. 2) Check radiator fan operation.	Does radiator fan continuously rotate for more than 3 minutes during idling?	Repair radiator fan circuit. <Ref. to CO-26, Radiator Main Fan and Fan Motor.> and <Ref. to CO-29, Radiator Sub Fan and Fan Motor.>	Replace thermostat. <Ref. to CO-19, Thermostat.>

MEMO:

DIAGNOSTIC PROCEDURE WITH DIAGNOSTIC TROUBLE CODE (DTC)

Engine (Diagnostics)

U: DTC P0130 — FRONT OXYGEN (A/F) SENSOR CIRCUIT RANGE/PERFORMANCE PROBLEM (LEAN) — S078521G44

- **DTC DETECTING CONDITION:**
 - Two consecutive driving cycles with fault

CAUTION:

After repair or replacement of faulty parts, conduct Clear Memory Mode <Ref. to EN-55, OPERATION, Clear Memory Mode.> and Inspection Mode <Ref. to EN-48, OPERATION, Inspection Mode.>.

● WIRING DIAGRAM:

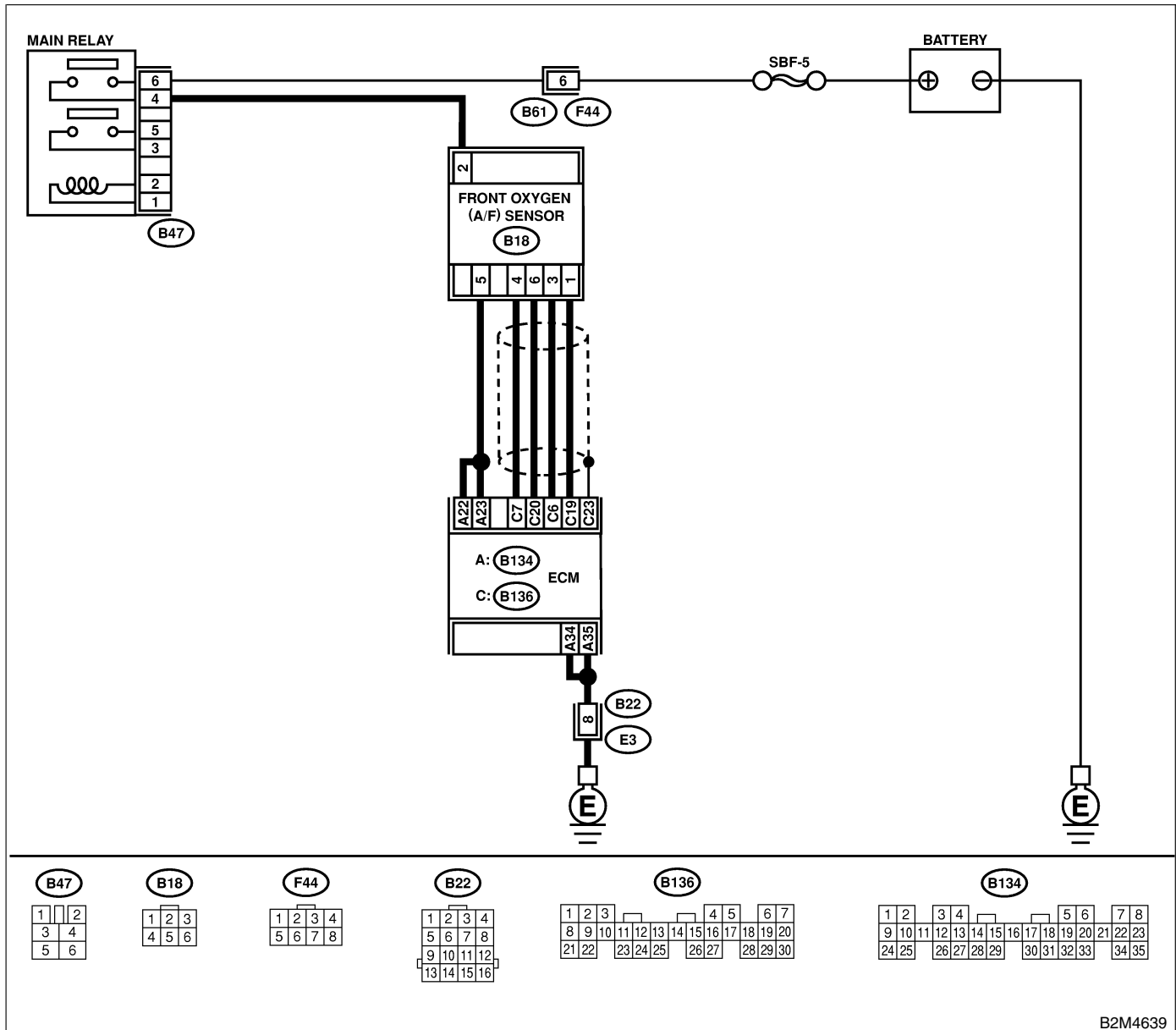

B2M4639

DIAGNOSTIC PROCEDURE WITH DIAGNOSTIC TROUBLE CODE (DTC)

Engine (Diagnostics)

No.	Step	Check	Yes	No
1	CHECK ANY OTHER DTC ON DISPLAY.	Is any other DTC displayed?	Inspect the relevant DTC using "List of Diagnostic Trouble Code (DTC)". <Ref. to EN-88, List of Diagnostic Trouble Code (DTC).>	Go to step 2.
2	CHECK FRONT OXYGEN (A/F) SENSOR DATA. 1) Start engine. 2) While observing the Subaru Select Monitor or OBD-II general scan tool screen, warm-up the engine until coolant temperature is above 70°C (158°F). If the engine is already warmed-up, operate at idle speed for at least 1 minute. 3) Read data of front oxygen (A/F) sensor signal using Subaru Select Monitor or OBD-II general scan tool. NOTE: ● Subaru Select Monitor For detailed operation procedure, refer to the "READ CURRENT DATA FOR ENGINE". <Ref. to EN-36, Subaru Select Monitor.> ● OBD-II general scan tool For detailed operation procedures, refer to the OBD-II General Scan Tool Instruction Manual.	Is the value equal to or more than 0.85 and equal to less than 1.15 in idling?	Go to step 3.	Go to step 4.
3	CHECK FRONT OXYGEN (A/F) SENSOR DATA. Race engine at speeds from idling to 5,000 rpm for a total of 5 cycles. NOTE: To increase engine speed to 5,000 rpm, slowly depress accelerator pedal, taking approximately 5 seconds, and quickly release accelerator pedal to decrease engine speed.	Is the value more than 1.1 for a moment?	Go to step 6.	Go to step 4.
4	CHECK HARNESS BETWEEN ECM AND FRONT OXYGEN (A/F) SENSOR. 1) Turn ignition switch to OFF. 2) Disconnect connector from ECM and front oxygen (A/F) sensor connector. 3) Measure resistance between ECM and front oxygen (A/F) sensor. Connector & terminals (B136) No. 6 — (B18) No. 1: (B136) No. 7 — (B18) No. 6: (B136) No. 19 — (B18) No. 3: (B136) No. 20 — (B18) No. 4:	Is the resistance less than 5 Ω?	Go to step 5.	Repair open circuit between ECM and front oxygen (A/F) sensor.
5	CHECK HARNESS BETWEEN ECM AND FRONT OXYGEN (A/F) SENSOR. Measure resistance between ECM and chassis ground. Connector & terminals (B136) No. 6 — Chassis ground: (B136) No. 7 — Chassis ground: (B136) No. 19 — Chassis ground: (B136) No. 20 — Chassis ground:	Is the resistance more than 1 MΩ?	Go to step 6.	Repair ground short circuit between ECM and front oxygen (A/F) sensor.

DIAGNOSTIC PROCEDURE WITH DIAGNOSTIC TROUBLE CODE (DTC)

Engine (Diagnostics)

No.	Step	Check	Yes	No
6	CHECK EXHAUST SYSTEM. Check exhaust system parts. NOTE: Check the following items. <ul style="list-style-type: none">● Loose installation of portions● Damage (crack, hole etc.) of parts● Looseness of front oxygen (A/F) sensor● Looseness and ill fitting of parts between front oxygen (A/F) sensor and rear oxygen sensor	Is there a fault in exhaust system?	Repair or replace faulty parts.	Replace front oxygen (A/F) sensor. <Ref. to FU-47, Front Oxygen (A/F) Sensor.>

MEMO:

DIAGNOSTIC PROCEDURE WITH DIAGNOSTIC TROUBLE CODE (DTC)

Engine (Diagnostics)

V: DTC P0131 — FRONT OXYGEN (A/F) SENSOR CIRCUIT MALFUNCTION (OPEN CIRCUIT) — S078521G45

● DTC DETECTING CONDITION:

- Two consecutive driving cycles with fault

CAUTION:

After repair or replacement of faulty parts, conduct Clear Memory Mode <Ref. to EN-55, OPERATION, Clear Memory Mode.> and Inspection Mode <Ref. to EN-48, OPERATION, Inspection Mode.>.

● WIRING DIAGRAM:

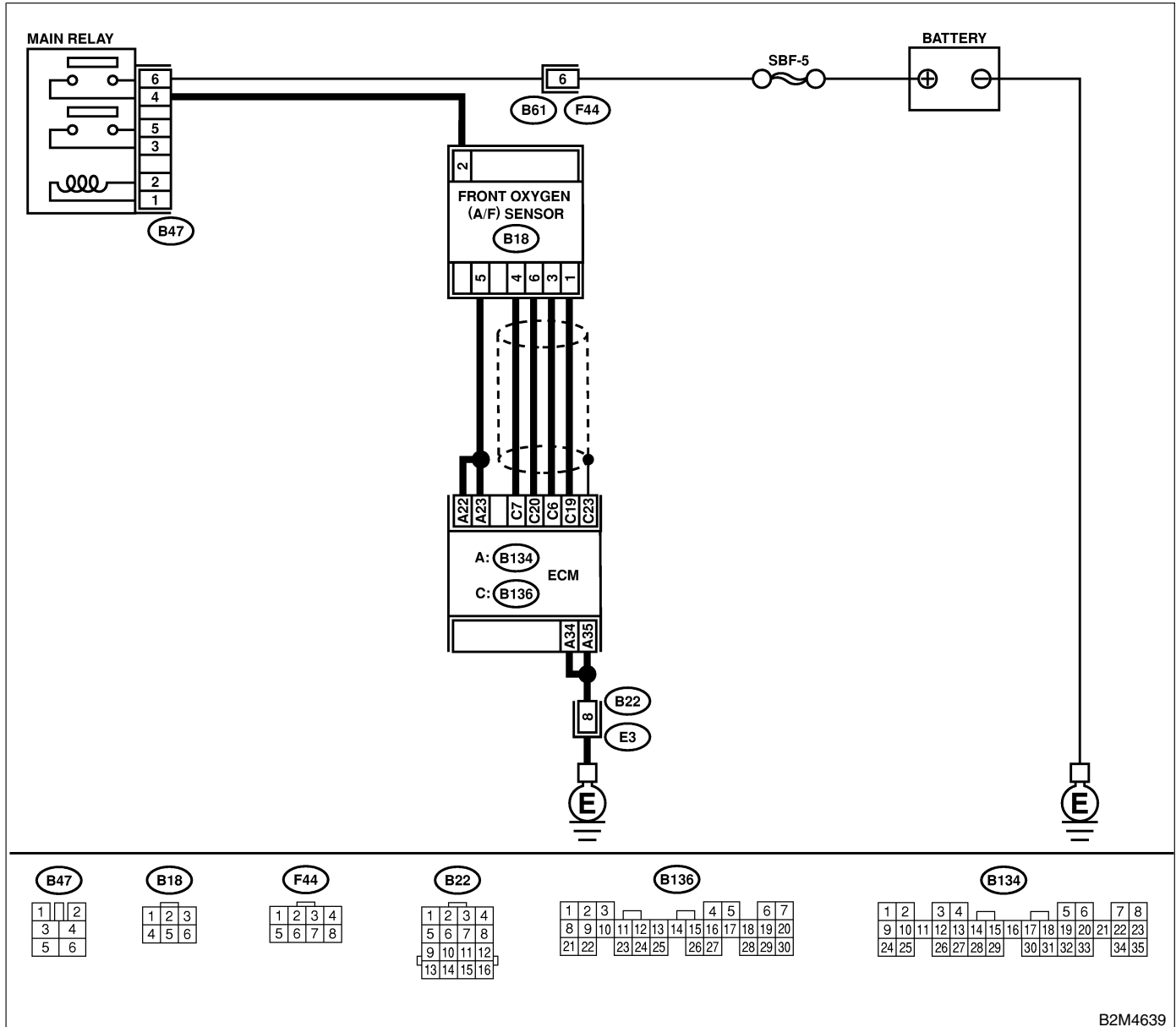

B2M4639

DIAGNOSTIC PROCEDURE WITH DIAGNOSTIC TROUBLE CODE (DTC)

Engine (Diagnostics)

No.	Step	Check	Yes	No
1	<p>CHECK HARNESS BETWEEN ECM AND FRONT OXYGEN (A/F) SENSOR CONNECTOR.</p> <p>1) Turn ignition switch to OFF. 2) Disconnect connectors from ECM and front oxygen (A/F) sensor connector. 3) Measure resistance of harness between ECM and front oxygen (A/F) sensor connector.</p> <p>Connector & terminal (B136) No. 6 — (E18) No. 1: (B136) No. 7 — (B18) No. 6: (B136) No. 19 — (B18) No. 3: (B136) No. 20 — (B18) No. 4:</p>	Is the resistance less than 1 Ω?	Go to step 2.	Repair harness and connector. NOTE: In this case, repair the following: <ul style="list-style-type: none"> ● Open circuit in harness between ECM and front oxygen (A/F) sensor connector ● Poor contact in front oxygen (A/F) sensor connector ● Poor contact in ECM connector
2	<p>CHECK POOR CONTACT.</p> <p>Check poor contact in front oxygen (A/F) sensor connector.</p>	Is there poor contact in front oxygen (A/F) sensor connector?	Repair poor contact in front oxygen (A/F) sensor connector.	Replace front oxygen (A/F) sensor. <Ref. to FU-47, Front Oxygen (A/F) Sensor.>

DIAGNOSTIC PROCEDURE WITH DIAGNOSTIC TROUBLE CODE (DTC)

Engine (Diagnostics)

W: DTC P0132 — FRONT OXYGEN (A/F) SENSOR CIRCUIT MALFUNCTION (SHORT CIRCUIT) — S078521G46

● DTC DETECTING CONDITION:

- Two consecutive driving cycles with fault

CAUTION:

After repair or replacement of faulty parts, conduct Clear Memory Mode <Ref. to EN-55, OPERATION, Clear Memory Mode.> and Inspection Mode <Ref. to EN-48, OPERATION, Inspection Mode.>.

● WIRING DIAGRAM:

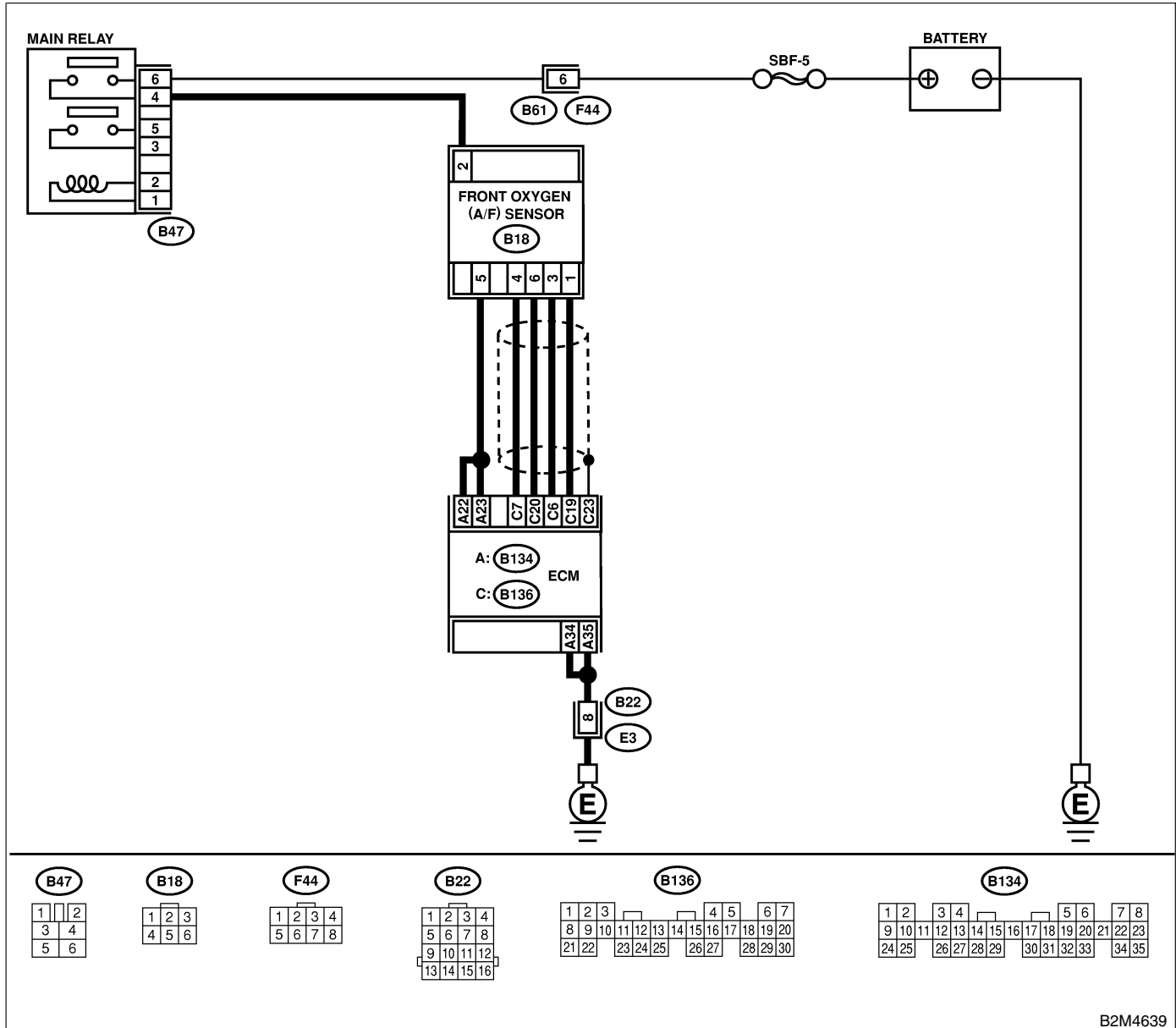

B2M4639

DIAGNOSTIC PROCEDURE WITH DIAGNOSTIC TROUBLE CODE (DTC)

Engine (Diagnostics)

No.	Step	Check	Yes	No
1	CHECK HARNESS BETWEEN ECM AND FRONT OXYGEN (A/F) SENSOR CONNECTOR. 1) Turn ignition switch to OFF. 2) Disconnect connector from ECM. 3) Measure resistance of harness between ECM connector and chassis ground. Connector & terminal <i>(B136) No. 6 — Chassis ground:</i> <i>(B136) No. 7 — Chassis ground:</i> <i>(B136) No. 19 — Chassis ground:</i> <i>(B136) No. 20 — Chassis ground:</i>	Is the resistance more than 10 Ω?	Replace front oxygen (A/F) sensor. <Ref. to FU-47, Front Oxygen (A/F) Sensor.>	Repair ground short circuit in harness between ECM and front oxygen (A/F) sensor connector.

DIAGNOSTIC PROCEDURE WITH DIAGNOSTIC TROUBLE CODE (DTC)

Engine (Diagnostics)

X: DTC P0133 — FRONT OXYGEN (A/F) SENSOR CIRCUIT SLOW RESPONSE — S078521B26

● DTC DETECTING CONDITION:

- Two consecutive driving cycles with fault

CAUTION:

After repair or replacement of faulty parts, conduct Clear Memory Mode <Ref. to EN-55, OPERATION, Clear Memory Mode.> and Inspection Mode <Ref. to EN-48, OPERATION, Inspection Mode.>.

● WIRING DIAGRAM:

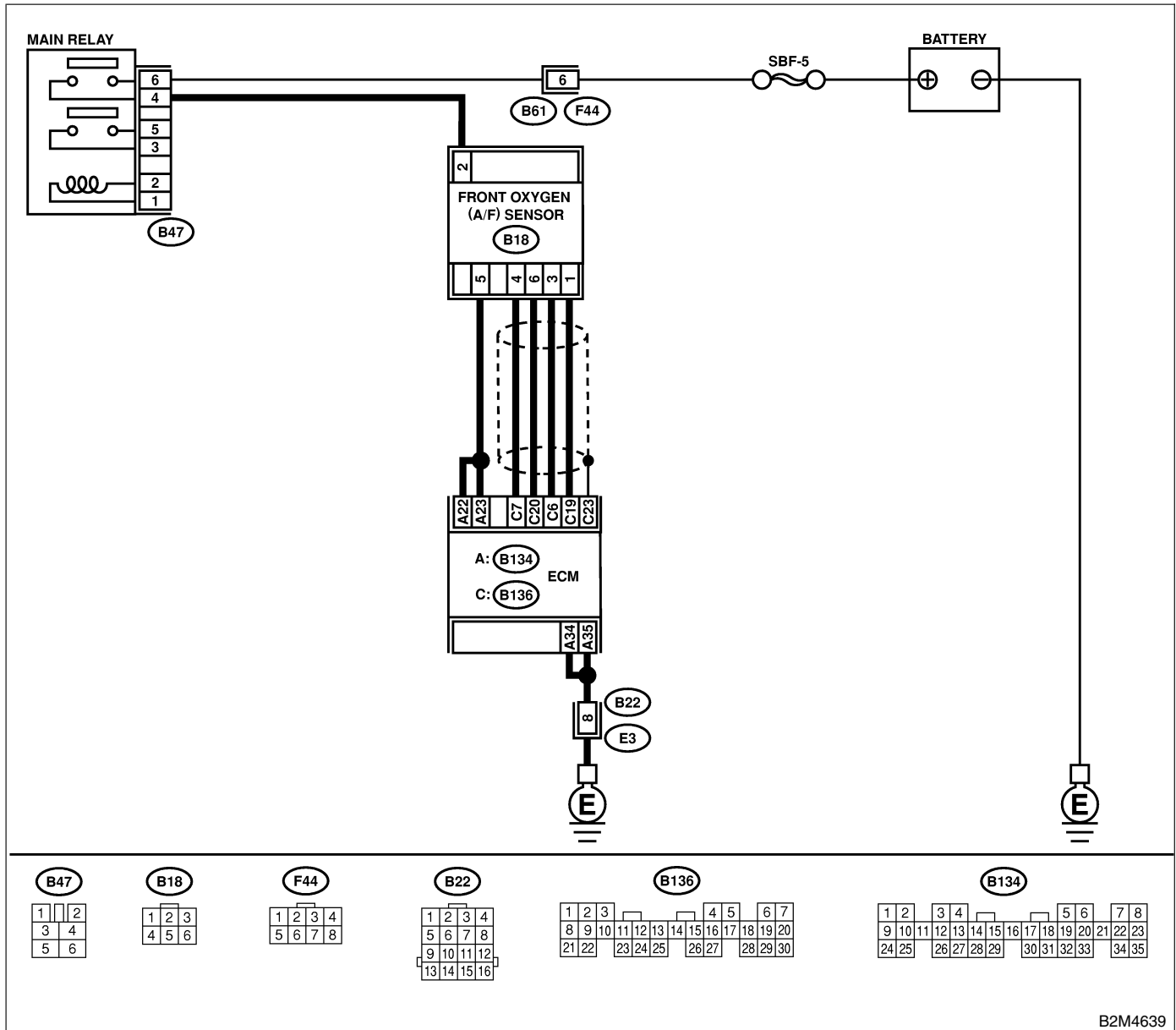

B2M4639

DIAGNOSTIC PROCEDURE WITH DIAGNOSTIC TROUBLE CODE (DTC)

Engine (Diagnostics)

No.	Step	Check	Yes	No
1	CHECK ANY OTHER DTC ON DISPLAY.	Is any other DTC displayed?	Inspect the relevant DTC using "List of Diagnostic Trouble Code (DTC)". <Ref. to EN-88, List of Diagnostic Trouble Code (DTC).> NOTE: In this case, it is not necessary to inspect DTC P0133.	Go to step 2.
2	CHECK EXHAUST SYSTEM. NOTE: Check the following items. <ul style="list-style-type: none">● Loose installation of front portion of exhaust pipe onto cylinder heads● Loose connection between front exhaust pipe and front catalytic converter● Damage of exhaust pipe resulting in a hole	Is there a fault in exhaust system?	Repair exhaust system.	Replace front oxygen (A/F) sensor. <Ref. to FU-47, Front Oxygen (A/F) Sensor.>

DIAGNOSTIC PROCEDURE WITH DIAGNOSTIC TROUBLE CODE (DTC)

Engine (Diagnostics)

Y: DTC P0137 — REAR OXYGEN SENSOR CIRCUIT LOW INPUT — S078521K17

• DTC DETECTING CONDITION:

- Two consecutive driving cycles with fault

CAUTION:

After repair or replacement of faulty parts, conduct Clear Memory Mode <Ref. to EN-55, OPERATION, Clear Memory Mode.> and Inspection Mode <Ref. to EN-48, OPERATION, Inspection Mode.>.

• WIRING DIAGRAM:

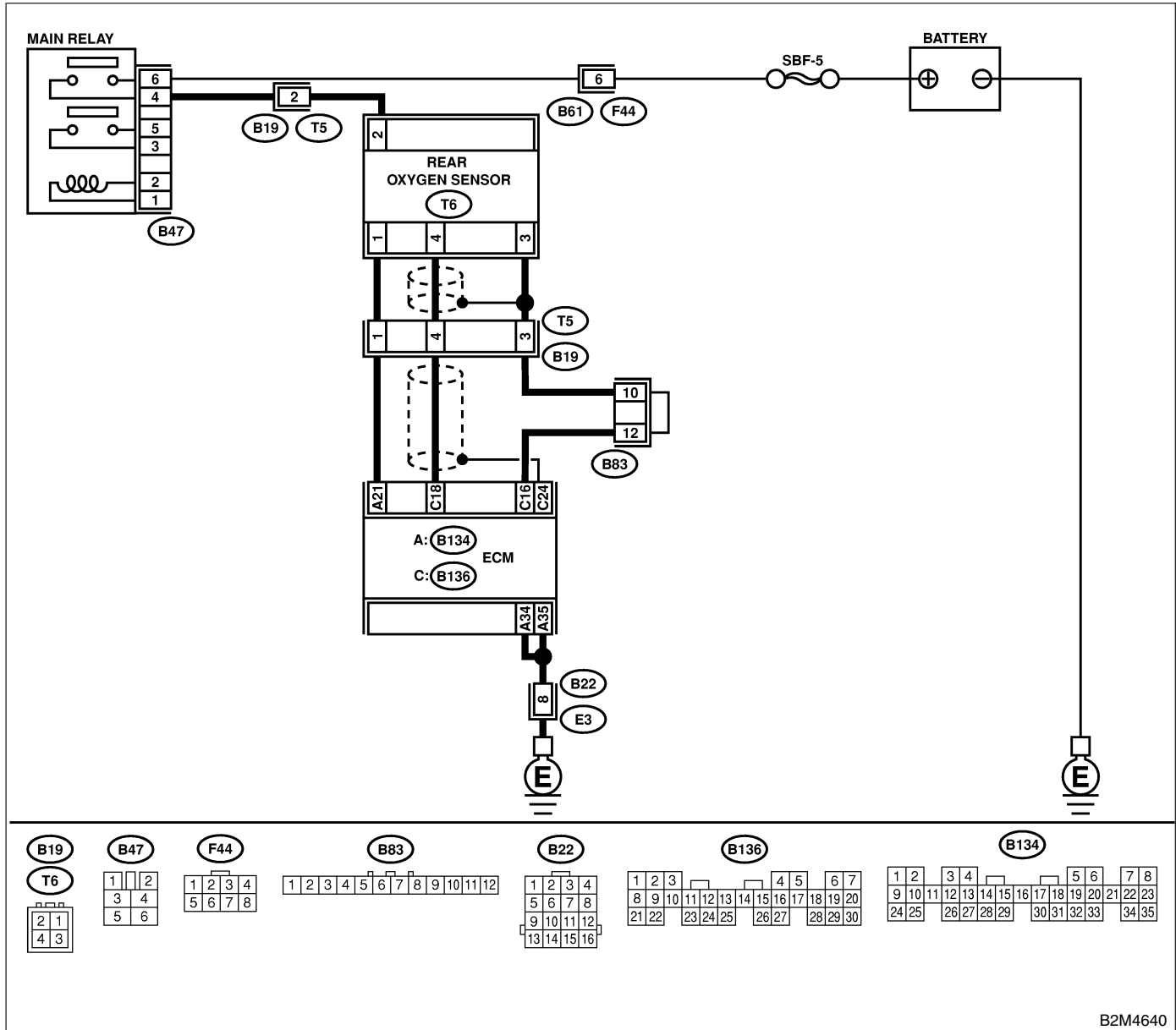

No.	Step	Check	Yes	No
1	CHECK ANY OTHER DTC ON DISPLAY.	Does the Subaru Select Monitor or OBD-II general scan tool indicate DTC P0131 or P0132?	Go to step 2.	Go to step 3.

DIAGNOSTIC PROCEDURE WITH DIAGNOSTIC TROUBLE CODE (DTC)

Engine (Diagnostics)

No.	Step	Check	Yes	No
2	<p>CHECK FAILURE CAUSE OF P0131 or P0132. Inspect DTC P0131 or P0132 using “List of Diagnostic Trouble Code (DTC)”. <Ref. to EN-88, List of Diagnostic Trouble Code (DTC).></p>	Is the failure cause of P0131 or P0132 in the fuel system?	Check fuel system. NOTE: In this case, it is not necessary to inspect DTC P0137.	Go to step 3.
3	<p>CHECK REAR OXYGEN SENSOR DATA. 1) Warm-up the engine until engine coolant temperature is above 70°C (158°F), and keep the engine speed at 2,000 rpm to 3,000 rpm for two minutes. 2) Read data of rear oxygen sensor signal using Subaru Select Monitor or OBD-II general scan tool. NOTE: ● Subaru Select Monitor For detailed operation procedure, refer to the “READ CURRENT DATA SHOWN ON DISPLAY FOR ENGINE”. <Ref. to EN-36, Subaru Select Monitor.> ● OBD-II general scan tool For detailed operation procedures, refer to the OBD-II General Scan Tool Instruction Manual.</p>	Does the value fluctuate?	Go to step 7.	Go to step 4.
4	<p>CHECK REAR OXYGEN SENSOR DATA. Read data of rear oxygen sensor signal using Subaru Select Monitor or OBD-II General Scan Tool.</p>	Is the value fixed between 0.2 and 0.4 V?	Go to step 5.	Replace rear oxygen sensor. <Ref. to FU-49, Rear Oxygen Sensor.>
5	<p>CHECK HARNESS BETWEEN ECM AND REAR OXYGEN SENSOR CONNECTOR. 1) Turn ignition switch to OFF. 2) Disconnect connectors from ECM and rear oxygen sensor. 3) Measure resistance of harness between ECM and rear oxygen sensor connector. Connector & terminal (B136) No. 16 — (T6) No. 3:</p>	Is the resistance more than 3 Ω?	Repair open circuit in harness between ECM and rear oxygen sensor connector.	Go to step 6.
6	<p>CHECK HARNESS BETWEEN REAR OXYGEN SENSOR AND ECM CONNECTOR. 1) Turn ignition switch to OFF. 2) Disconnect connector from rear oxygen sensor. 3) Turn ignition switch to ON. 4) Measure voltage between rear oxygen sensor harness connector and engine ground or chassis ground. Connector & terminal (T6) No. 4 (+) — Engine ground (-):</p>	Is the voltage more than 0.2 V?	Replace rear oxygen sensor. <Ref. to FU-49, Rear Oxygen Sensor.>	Repair harness and connector. NOTE: In this case, repair the following: ● Open circuit in harness between rear oxygen sensor and ECM connector ● Poor contact in rear oxygen sensor connector ● Poor contact in ECM connector

DIAGNOSTIC PROCEDURE WITH DIAGNOSTIC TROUBLE CODE (DTC)

Engine (Diagnostics)

No.	Step	Check	Yes	No
7	CHECK EXHAUST SYSTEM. Check exhaust system parts. NOTE: Check the following items. <ul style="list-style-type: none">● Loose installation of portions● Damage (crack, hole etc.) of parts● Looseness and ill fitting of parts between front oxygen (A/F) sensor and rear oxygen sensor	Is there a fault in exhaust system?	Repair or replace faulty parts.	Replace rear oxygen sensor. <Ref. to FU-49, Rear Oxygen Sensor.>

MEMO:

DIAGNOSTIC PROCEDURE WITH DIAGNOSTIC TROUBLE CODE (DTC)

Engine (Diagnostics)

Z: DTC P0138 — REAR OXYGEN SENSOR CIRCUIT HIGH INPUT — S078521K18

- **DTC DETECTING CONDITION:**
 - Two consecutive driving cycles with fault

CAUTION:

After repair or replacement of faulty parts, conduct Clear Memory Mode <Ref. to EN-55, OPERATION, Clear Memory Mode.> and Inspection Mode <Ref. to EN-48, OPERATION, Inspection Mode.>.

● **WIRING DIAGRAM:**

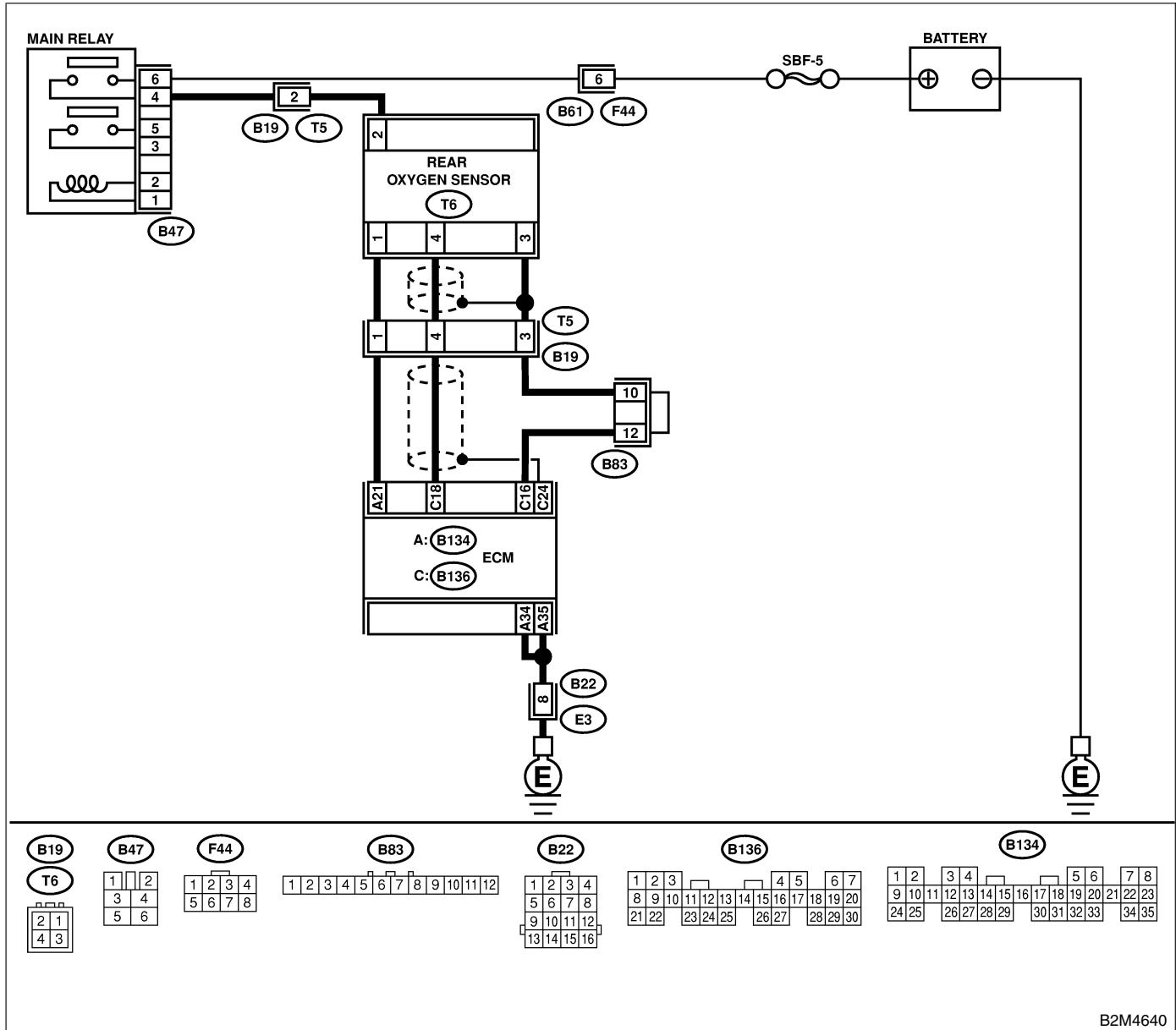

B2M4640

No.	Step	Check	Yes	No
1	CHECK ANY OTHER DTC ON DISPLAY.	Does the Subaru Select Monitor or OBD-II general scan tool indicate DTC P0131 or P0132?	Go to step 2.	Go to step 3.

DIAGNOSTIC PROCEDURE WITH DIAGNOSTIC TROUBLE CODE (DTC)

Engine (Diagnostics)

No.	Step	Check	Yes	No
2	<p>CHECK FAILURE CAUSE OF P0131 or P0132. Inspect DTC P0131 or P0132 using “List of Diagnostic Trouble Code (DTC)”. <Ref. to EN-88, List of Diagnostic Trouble Code (DTC).></p>	Is the failure cause of P0131 or P0132 in the fuel system?	Check fuel system. NOTE: In this case, it is not necessary to inspect DTC P0138.	Go to step 3.
3	<p>CHECK REAR OXYGEN SENSOR DATA. 1) Warm-up the engine until engine coolant temperature is above 70°C (158°F), and keep the engine speed at 2,000 rpm to 3,000 rpm for two minutes. 2) Read data of rear oxygen sensor signal using Subaru Select Monitor or OBD-II general scan tool. NOTE: ● Subaru Select Monitor For detailed operation procedure, refer to the “READ CURRENT DATA SHOWN ON DISPLAY FOR ENGINE”. <Ref. to EN-36, Subaru Select Monitor.> ● OBD-II general scan tool For detailed operation procedures, refer to the OBD-II General Scan Tool Instruction Manual.</p>	Does the value fluctuate?	Go to step 7.	Go to step 4.
4	<p>CHECK REAR OXYGEN SENSOR DATA. Read data of rear oxygen sensor signal using Subaru Select Monitor or OBD-II General Scan Tool.</p>	Is the value fixed between 0.2 and 0.4 V?	Go to step 5.	Replace rear oxygen sensor. <Ref. to FU-49, Rear Oxygen Sensor.>
5	<p>CHECK HARNESS BETWEEN ECM AND REAR OXYGEN SENSOR CONNECTOR. 1) Turn ignition switch to OFF. 2) Disconnect connectors from ECM and rear oxygen sensor. 3) Measure resistance of harness between ECM and rear oxygen sensor connector. Connector & terminal (B136) No. 16 — (T6) No. 3:</p>	Is the resistance more than 3 Ω?	Repair open circuit in harness between ECM and rear oxygen sensor connector.	Go to step 6.
6	<p>CHECK HARNESS BETWEEN REAR OXYGEN SENSOR AND ECM CONNECTOR. 1) Turn ignition switch to OFF. 2) Disconnect connector from rear oxygen sensor. 3) Turn ignition switch to ON. 4) Measure voltage between rear oxygen sensor harness connector and engine ground or chassis ground. Connector & terminal (T6) No. 4 (+) — Engine ground (-):</p>	Is the voltage more than 0.2 V?	Replace rear oxygen sensor. <Ref. to FU-49, Rear Oxygen Sensor.>	Repair harness and connector. NOTE: In this case, repair the following: ● Open circuit in harness between rear oxygen sensor and ECM connector ● Poor contact in rear oxygen sensor connector ● Poor contact in ECM connector

DIAGNOSTIC PROCEDURE WITH DIAGNOSTIC TROUBLE CODE (DTC)

Engine (Diagnostics)

No.	Step	Check	Yes	No
7	CHECK EXHAUST SYSTEM. Check exhaust system parts. NOTE: Check the following items. <ul style="list-style-type: none">● Loose installation of portions● Damage (crack, hole etc.) of parts● Looseness and ill fitting of parts between front oxygen (A/F) sensor and rear oxygen sensor	Is there a fault in exhaust system?	Repair or replace faulty parts.	Replace rear oxygen sensor. <Ref. to FU-49, Rear Oxygen Sensor.>

MEMO:

DIAGNOSTIC PROCEDURE WITH DIAGNOSTIC TROUBLE CODE (DTC)

Engine (Diagnostics)

AA: DTC P0139 — REAR OXYGEN SENSOR CIRCUIT SLOW RESPONSE —

S078521B29

● DTC DETECTING CONDITION:

- Two consecutive driving cycles with fault

CAUTION:

After repair or replacement of faulty parts, conduct Clear Memory Mode <Ref. to EN-55, OPERATION, Clear Memory Mode.> and Inspection Mode <Ref. to EN-48, OPERATION, Inspection Mode.>.

● WIRING DIAGRAM:

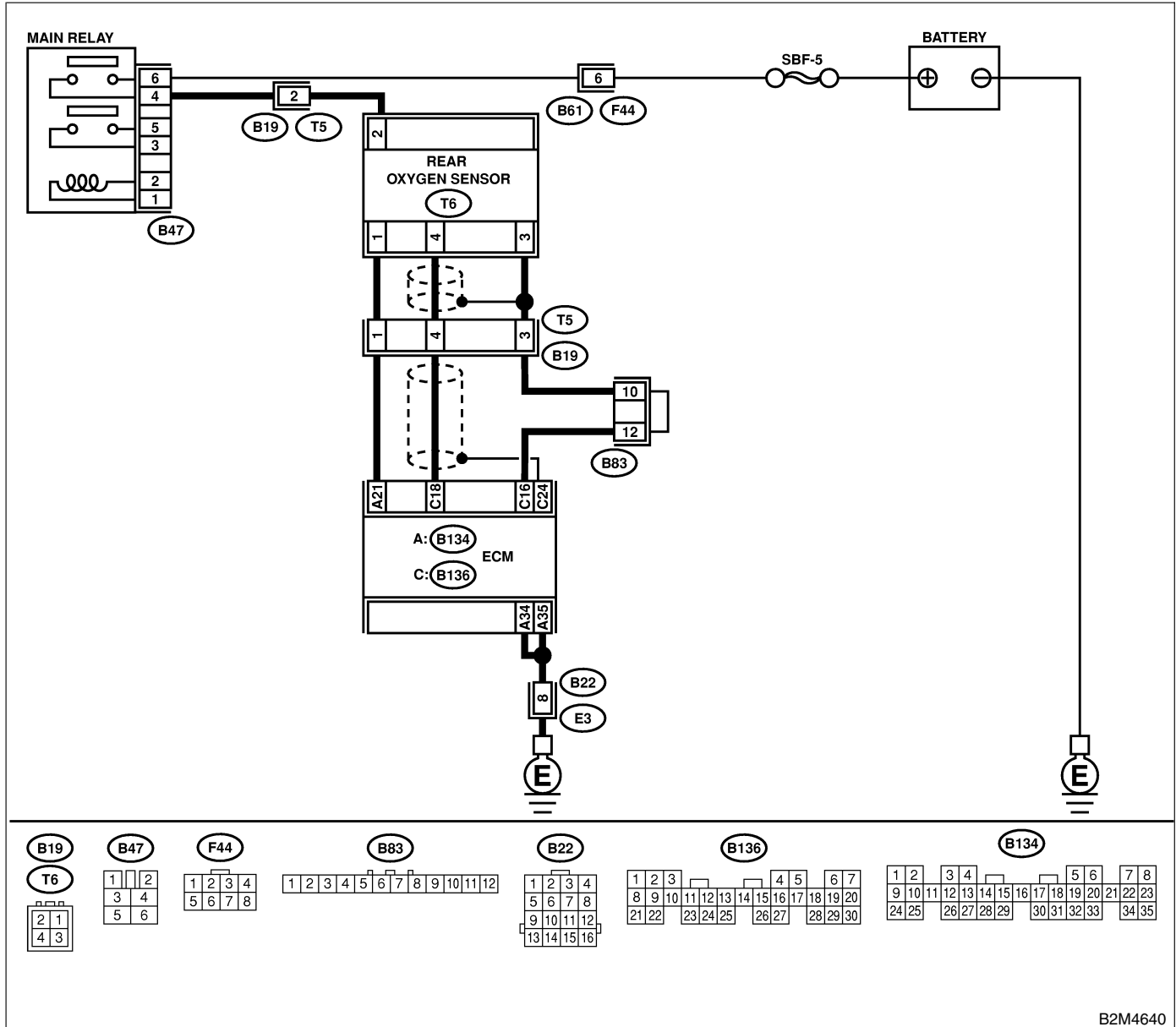

B2M4640

DIAGNOSTIC PROCEDURE WITH DIAGNOSTIC TROUBLE CODE (DTC)

Engine (Diagnostics)

No.	Step	Check	Yes	No
1	CHECK ANY OTHER DTC ON DISPLAY.	Is any other DTC displayed?	Inspect the relevant DTC using "List of Diagnostic Trouble Code (DTC)". <Ref. to EN-88, List of Diagnostic Trouble Code (DTC).> NOTE: In this case, it is not necessary to inspect DTC P0139.	Replace rear oxygen sensor. <Ref. to FU-49, Rear Oxygen Sensor.>

DIAGNOSTIC PROCEDURE WITH DIAGNOSTIC TROUBLE CODE (DTC)

Engine (Diagnostics)

AB: DTC P0171 — FUEL TRIM MALFUNCTION (A/F TOO LEAN)— S078521B33

NOTE:

For the diagnostic procedure, refer to DTC P0172. <Ref. to EN-170, DTC P0172 — FUEL TRIM #1 (RH) MALFUNCTION (A/F TOO RICH) —, Diagnostic Procedure with Diagnostic Trouble Code (DTC).>

AC: DTC P0172 — FUEL TRIM #1 (RH) MALFUNCTION (A/F TOO RICH) — S078521H36

● DTC DETECTING CONDITION:

- Two consecutive driving cycles with fault

● TROUBLE SYMPTOM:

- Erroneous idling
- Engine stalls.
- Poor driving performance

CAUTION:

After repair or replacement of faulty parts, conduct Clear Memory Mode <Ref. to EN-55, OPERATION, Clear Memory Mode.> and Inspection Mode <Ref. to EN-48, OPERATION, Inspection Mode.>.

No.	Step	Check	Yes	No
1	CHECK ANY OTHER DTC ON DISPLAY.	Is any other DTC displayed?	Inspect the relevant DTC using "List of Diagnostic Trouble Code (DTC)". <Ref. to EN(H6)-96, List of Diagnostic Trouble Code (DTC).>	Go to step 2.
2	CHECK EXHAUST SYSTEM.	Are there holes or loose bolts on exhaust system?	Repair exhaust system.	Go to step 3.
3	CHECK AIR INTAKE SYSTEM.	Are there holes, loose bolts or disconnection of hose on air intake system?	Repair air intake system.	Go to step 4.
4	CHECK FUEL PRESSURE. WARNING: <ul style="list-style-type: none"> ● Place "NO FIRE" signs near the working area. ● Be careful not to spill fuel on the floor. 1) Release fuel pressure. <ol style="list-style-type: none"> (1) Disconnect connector from fuel pump relay. (2) Start the engine and run it until it stalls. (3) After the engine stalls, crank it for five more seconds. (4) Turn ignition switch to OFF. 2) Connect connector to fuel pump relay. 3) Disconnect fuel delivery hose from fuel filter, and connect fuel pressure gauge. 4) Install fuel filler cap. 5) Start the engine and idle while gear position is neutral. 6) Measure fuel pressure while disconnecting pressure regulator vacuum hose from intake manifold. WARNING: Before removing fuel pressure gauge, release fuel pressure. NOTE: If fuel pressure does not increase, squeeze fuel return hose 2 to 3 times, then measure fuel pressure again.	Is fuel pressure between 284 and 314 kPa (2.9 — 3.2 kg/cm ² , 41 — 46 psi)?	Go to step 5.	Repair the following items. Fuel pressure too high <ul style="list-style-type: none"> ● Clogged fuel return line or bent hose Fuel pressure too low <ul style="list-style-type: none"> ● Improper fuel pump discharge ● Clogged fuel supply line

DIAGNOSTIC PROCEDURE WITH DIAGNOSTIC TROUBLE CODE (DTC)

Engine (Diagnostics)

No.	Step	Check	Yes	No
5	<p>CHECK FUEL PRESSURE. After connecting pressure regulator vacuum hose, measure fuel pressure.</p> <p>WARNING: Before removing fuel pressure gauge, release fuel pressure.</p> <p>NOTE:</p> <ul style="list-style-type: none"> ● If fuel pressure does not increase, squeeze fuel return hose 2 to 3 times, then measure fuel pressure again. ● If out of specification as measured at this step, check or replace pressure regulator and pressure regulator vacuum hose. 	Is fuel pressure between 206 and 235 kPa (2.1 — 2.4 kg/cm ² , 30 — 34 psi)?	Go to step 6.	Repair the following items. Fuel pressure too high <ul style="list-style-type: none"> ● Faulty pressure regulator ● Clogged fuel return line or bent hose Fuel pressure too low <ul style="list-style-type: none"> ● Faulty pressure regulator ● Improper fuel pump discharge ● Clogged fuel supply line
6	<p>CHECK ENGINE COOLANT TEMPERATURE SENSOR.</p> <ol style="list-style-type: none"> 1) Start the engine and warm-up completely. 2) Read data of engine coolant temperature sensor signal using Subaru Select Monitor or OBD-II general scan tool. <p>NOTE:</p> <ul style="list-style-type: none"> ● Subaru Select Monitor For detailed operation procedure, refer to the "READ CURRENT DATA FOR ENGINE". <Ref. to EN-36, Subaru Select Monitor.> ● OBD-II general scan tool For detailed operation procedures, refer to the OBD-II General Scan Tool Instruction Manual. 	Is temperature between 70°C (158°F) and 100°C (212°F)?	Go to step 7.	Replace engine coolant temperature sensor. <Ref. to FU-30, Engine Coolant Temperature Sensor.>
7	<p>CHECK INTAKE MANIFOLD PRESSURE SENSOR SIGNAL.</p> <ol style="list-style-type: none"> 1) Start the engine and warm-up engine until coolant temperature is greater than 60°C (140°F). 2) Place the selector lever in "N" or "P" position. 3) Turn A/C switch to OFF. 4) Turn all accessory switches to OFF. 5) Read data of intake manifold pressure sensor signal using Subaru Select Monitor or OBD-II general scan tool. <p>NOTE:</p> <ul style="list-style-type: none"> ● Subaru Select Monitor For detailed operation procedure, refer to the "READ CURRENT DATA FOR ENGINE". <Ref. to EN-36, Subaru Select Monitor.> ● OBD-II general scan tool For detailed operation procedures, refer to the OBD-II General Scan Tool Instruction Manual. <p>Specification:</p> <p>Idling 24.0 — 41.3 kPa (180 — 310 mmHg, 7.09 — 12.20 inHg)</p> <p>Ignition ON 73.3 — 106.6 kPa (550 — 800 mmHg, 21.65 — 31.50 inHg)</p>	Is the voltage within the specifications?	Contact with SOA (distributor) service. NOTE: Inspection by DTM is required, because probable cause is deterioration of multiple parts.	Replace intake air temperature and pressure sensor. <Ref. to FU-38, Intake Air Temperature and Pressure Sensor.>

DIAGNOSTIC PROCEDURE WITH DIAGNOSTIC TROUBLE CODE (DTC)

Engine (Diagnostics)

AD: DTC P0181 — FUEL TEMPERATURE SENSOR A CIRCUIT RANGE/PERFORMANCE PROBLEM —

S078521B34

● DTC DETECTING CONDITION:

- Two consecutive driving cycles with fault

CAUTION:

After repair or replacement of faulty parts, conduct Clear Memory Mode <Ref. to EN-55, OPERATION, Clear Memory Mode.> and Inspection Mode <Ref. to EN-48, OPERATION, Inspection Mode.>.

● WIRING DIAGRAM:

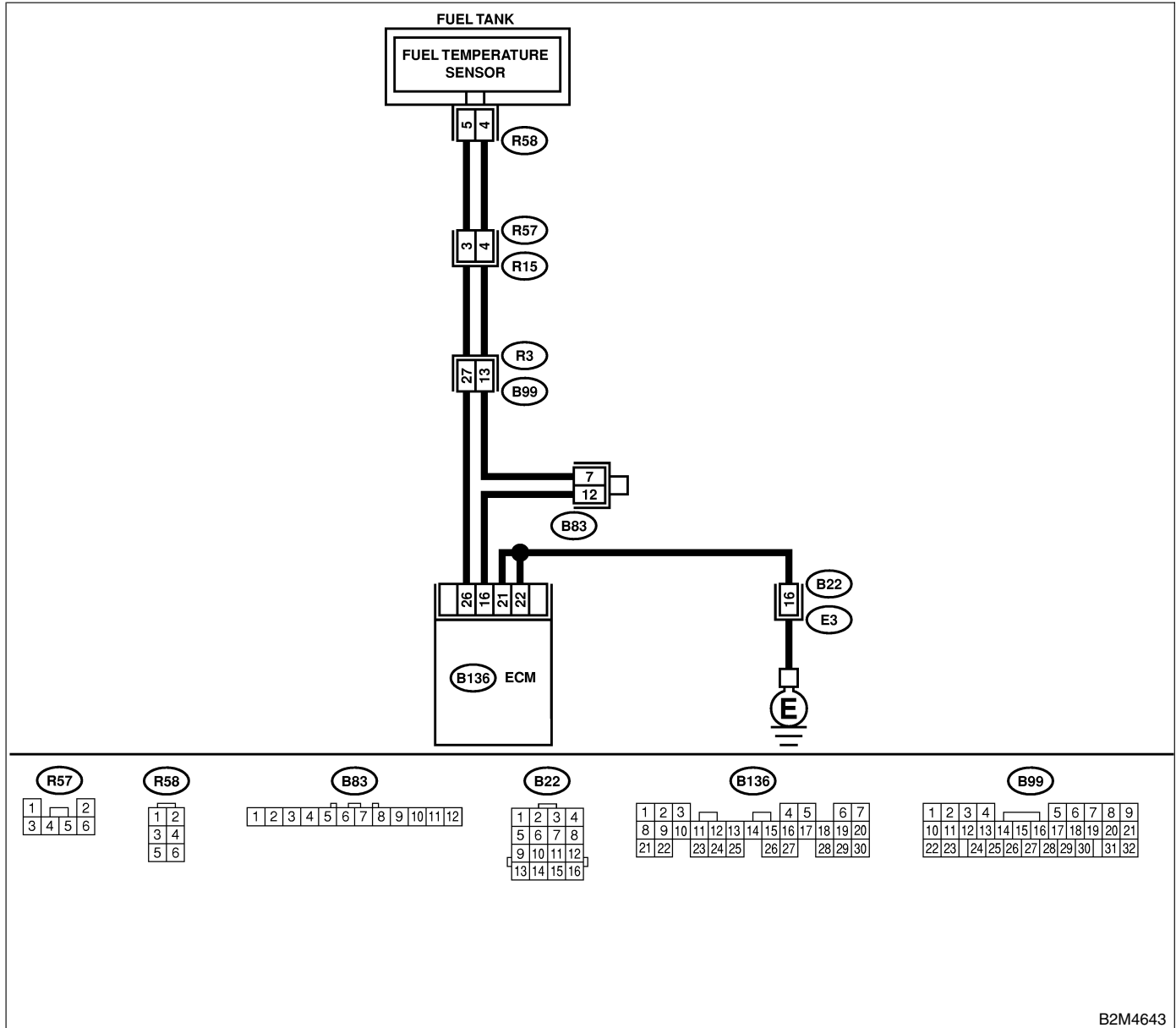

DIAGNOSTIC PROCEDURE WITH DIAGNOSTIC TROUBLE CODE (DTC)

Engine (Diagnostics)

No.	Step	Check	Yes	No
1	CHECK ANY OTHER DTC ON DISPLAY.	Is any other DTC displayed?	Inspect the relevant DTC using "List of Diagnostic Trouble Code (DTC)". <Ref. to EN-88, List of Diagnostic Trouble Code (DTC).> NOTE: In this case, it is not necessary to inspect DTC P0181.	Replace fuel temperature sensor. <Ref. to EC-8, Fuel Temperature Sensor.>

DIAGNOSTIC PROCEDURE WITH DIAGNOSTIC TROUBLE CODE (DTC)

Engine (Diagnostics)

AE: DTC P0182 — FUEL TEMPERATURE SENSOR A CIRCUIT LOW INPUT —

S078521B35

- **DTC DETECTING CONDITION:**
 - Immediately at fault recognition

CAUTION:

After repair or replacement of faulty parts, conduct Clear Memory Mode <Ref. to EN-55, OPERATION, Clear Memory Mode.> and Inspection Mode <Ref. to EN-48, OPERATION, Inspection Mode.>.

- **WIRING DIAGRAM:**

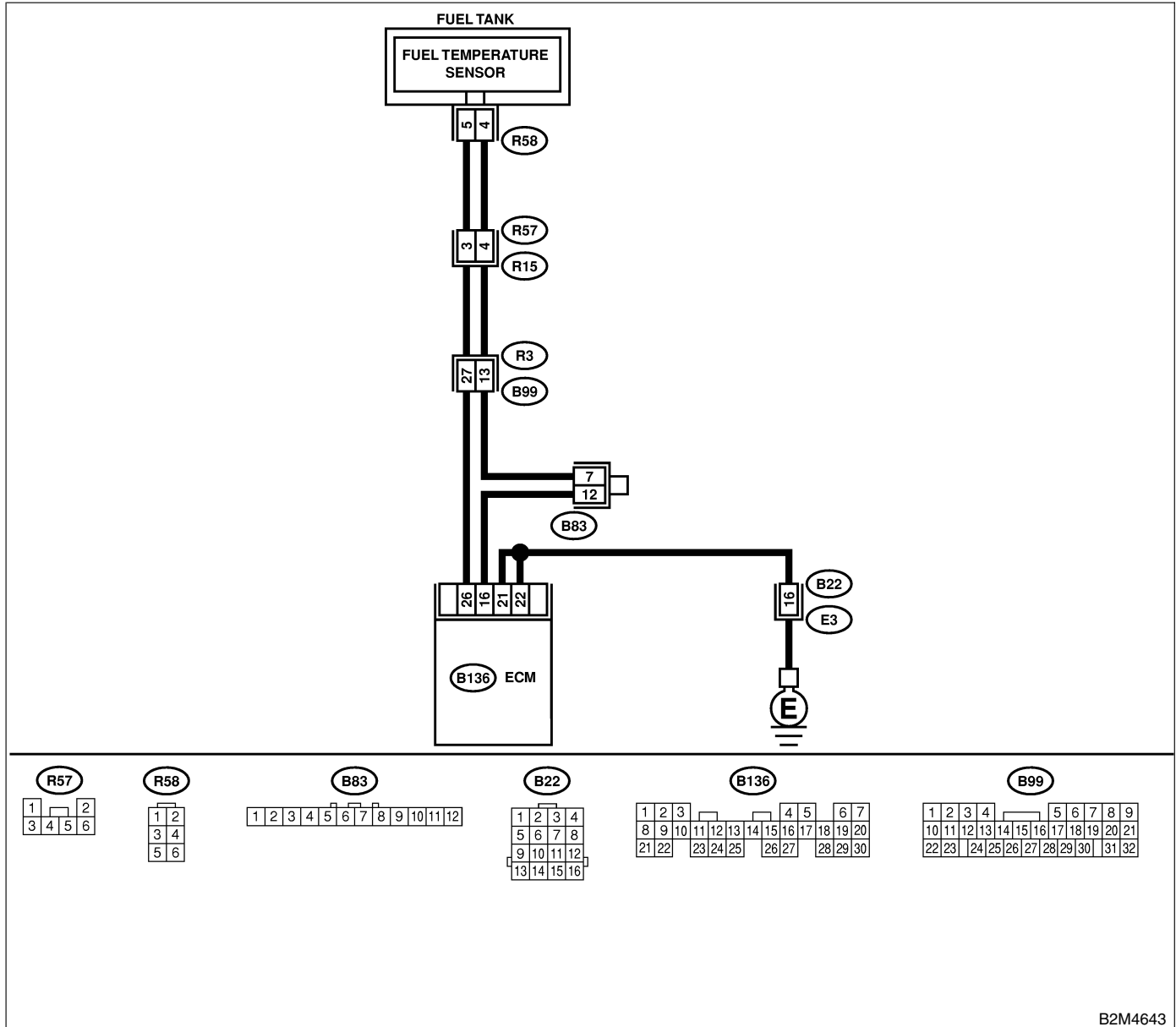

DIAGNOSTIC PROCEDURE WITH DIAGNOSTIC TROUBLE CODE (DTC)

Engine (Diagnostics)

No.	Step	Check	Yes	No
1	<p>CHECK CURRENT DATA.</p> <p>1) Start engine. 2) Read data of fuel temperature sensor signal using Subaru Select Monitor or OBD-II general scan tool.</p> <p>NOTE:</p> <ul style="list-style-type: none">● Subaru Select Monitor <p>For detailed operation procedure, refer to the "READ CURRENT DATA FOR ENGINE". <Ref. to EN-36, Subaru Select Monitor.></p> <ul style="list-style-type: none">● OBD-II general scan tool <p>For detailed operation procedures, refer to the OBD-II General Scan Tool Instruction Manual.</p>	Is the value greater than 150°C (302°F)?	Go to step 2.	Even if MIL lights up, the circuit has returned to a normal condition at this time.
2	<p>CHECK CURRENT DATA.</p> <p>1) Turn ignition switch to OFF. 2) Remove access hole lid. 3) Disconnect connector from fuel pump. 4) Turn ignition switch to ON. 5) Read data of fuel temperature sensor signal using Subaru Select Monitor or the OBD-II general scan tool.</p> <p>NOTE:</p> <ul style="list-style-type: none">● Subaru Select Monitor <p>For detailed operation procedure, refer to the "READ CURRENT DATA FOR ENGINE". <Ref. to EN-36, Subaru Select Monitor.></p> <ul style="list-style-type: none">● OBD-II general scan tool <p>For detailed operation procedures, refer to the OBD-II General Scan Tool Instruction Manual.</p>	Is the value less than -40°C (-40°F)?	Replace fuel temperature sensor. <Ref. to EC-8, Fuel Temperature Sensor.>	Repair ground short circuit in harness between fuel pump and ECM connector.

DIAGNOSTIC PROCEDURE WITH DIAGNOSTIC TROUBLE CODE (DTC)

Engine (Diagnostics)

AF: DTC P0183 — FUEL TEMPERATURE SENSOR A CIRCUIT HIGH INPUT —

S078521B36

- **DTC DETECTING CONDITION:**
 - Immediately at fault recognition

CAUTION:

After repair or replacement of faulty parts, conduct Clear Memory Mode <Ref. to EN-55, OPERATION, Clear Memory Mode.> and Inspection Mode <Ref. to EN-48, OPERATION, Inspection Mode.>.

● WIRING DIAGRAM:

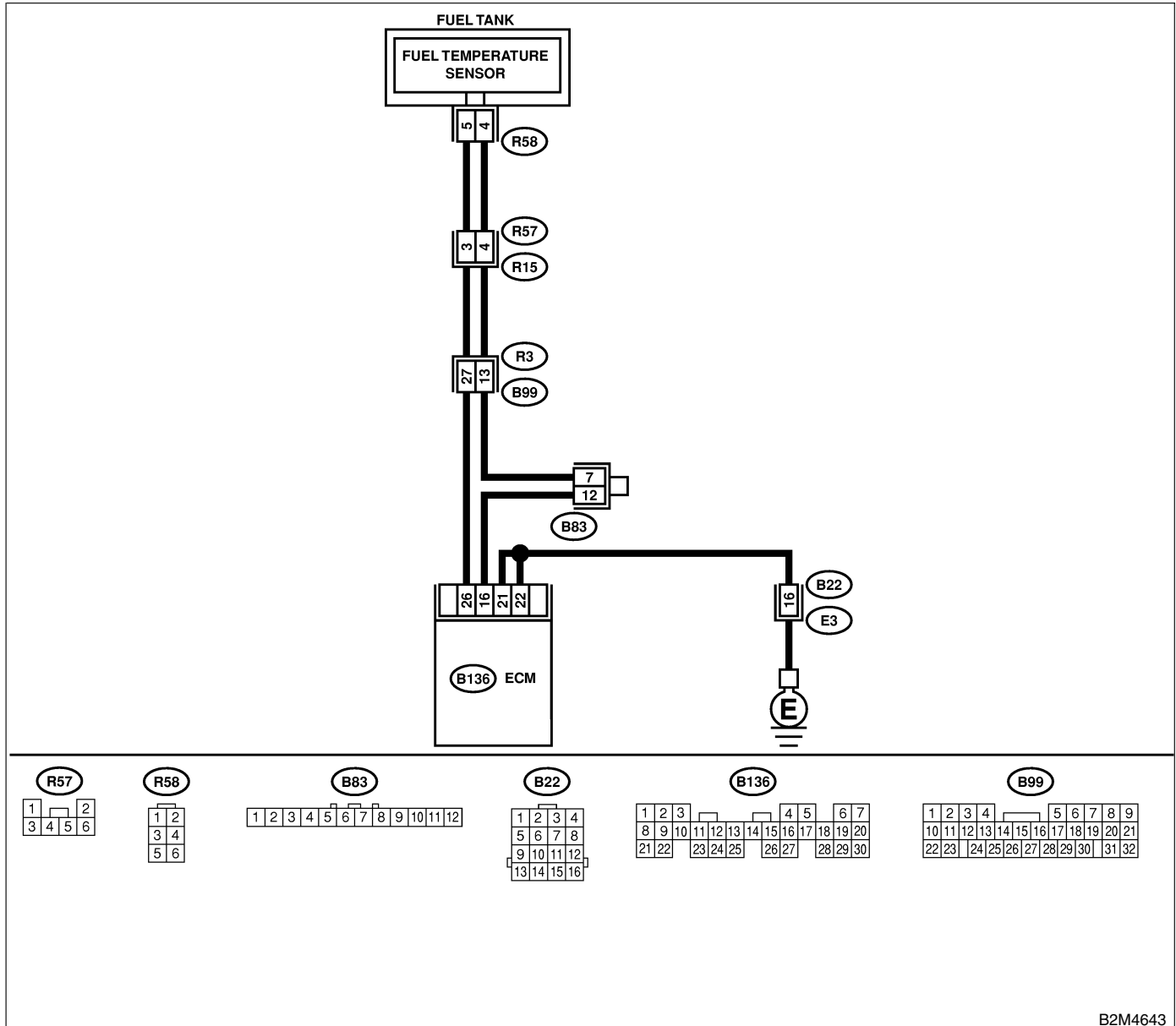

B2M4643

DIAGNOSTIC PROCEDURE WITH DIAGNOSTIC TROUBLE CODE (DTC)

Engine (Diagnostics)

No.	Step	Check	Yes	No
1	<p>CHECK CURRENT DATA.</p> <p>1) Start engine. 2) Read data of fuel temperature sensor signal using Subaru Select Monitor or OBD-II general scan tool.</p> <p>NOTE:</p> <ul style="list-style-type: none"> ● Subaru Select Monitor <p>For detailed operation procedure, refer to the "READ CURRENT DATA FOR ENGINE". <Ref. to EN-36, Subaru Select Monitor.></p> <ul style="list-style-type: none"> ● OBD-II general scan tool <p>For detailed operation procedures, refer to the OBD-II General Scan Tool Instruction Manual.</p>	Is the value less than -40°C (-40°F)?	Go to step 2.	<p>Repair poor contact.</p> <p>NOTE:</p> <p>In this case, repair the following:</p> <ul style="list-style-type: none"> ● Poor contact in fuel pump connector ● Poor contact in ECM connector ● Poor contact in coupling connectors ● Poor contact in joint connector
2	<p>CHECK HARNESS BETWEEN FUEL TEMPERATURE SENSOR AND ECM CONNECTOR.</p> <p>1) Turn ignition switch to OFF. 2) Remove access hole lid. 3) Disconnect connector from fuel pump. 4) Measure voltage between fuel pump connector and chassis ground.</p> <p>Connector & terminal (R58) No. 5 (+) — Chassis ground (-):</p>	Is the voltage more than 10 V?	Repair battery short circuit in harness between ECM and fuel pump connector.	Go to step 3.
3	<p>CHECK HARNESS BETWEEN FUEL TEMPERATURE SENSOR AND ECM CONNECTOR.</p> <p>1) Turn ignition switch to ON. 2) Measure voltage between fuel pump connector and chassis ground.</p> <p>Connector & terminal (R58) No. 5 (+) — Chassis ground (-):</p>	Is the voltage more than 10 V?	Repair battery short circuit in harness between ECM and fuel pump connector.	Go to step 4.
4	<p>CHECK HARNESS BETWEEN FUEL TEMPERATURE SENSOR AND ECM CONNECTOR.</p> <p>Measure voltage between fuel pump connector and chassis ground.</p> <p>Connector & terminal (R58) No. 5 (+) — Chassis ground (-):</p>	Is the voltage more than 4 V?	Go to step 5.	<p>Repair harness and connector.</p> <p>NOTE:</p> <p>In this case, repair the following:</p> <ul style="list-style-type: none"> ● Open circuit in harness between ECM and fuel pump connector ● Poor contact in fuel pump connector ● Poor contact in ECM connector ● Poor contact in coupling connectors

DIAGNOSTIC PROCEDURE WITH DIAGNOSTIC TROUBLE CODE (DTC)

Engine (Diagnostics)

No.	Step	Check	Yes	No
5	<p>CHECK HARNESS BETWEEN FUEL TEMPERATURE SENSOR AND ECM CONNECTOR.</p> <p>1) Turn ignition switch to OFF. 2) Measure resistance of harness between fuel pump connector and chassis ground.</p> <p>Connector & terminal (R58) No. 4 — Chassis ground:</p>	Is the resistance less than 5 Ω ?	Replace fuel temperature sensor. <Ref. to EC-8, Fuel Temperature Sensor.>	Repair harness and connector. NOTE: In this case, repair the following: <ul style="list-style-type: none">● Open circuit in harness between ECM and fuel pump connector● Poor contact in fuel pump connector● Poor contact in ECM connector● Poor contact in coupling connectors● Poor contact in joint connector

AG: DTC P0301 — CYLINDER 1 MISFIRE DETECTED — S078521B37

NOTE:

For the diagnostic procedure, refer to DTC P0304. <Ref. to EN-180, DTC P0304 — CYLINDER 4 MISFIRE DETECTED —, Diagnostic Procedure with Diagnostic Trouble Code (DTC).>

AH: DTC P0302 — CYLINDER 2 MISFIRE DETECTED — S078521B38

NOTE:

For the diagnostic procedure, refer to DTC P0304. <Ref. to EN-180, DTC P0304 — CYLINDER 4 MISFIRE DETECTED —, Diagnostic Procedure with Diagnostic Trouble Code (DTC).>

AI: DTC P0303 — CYLINDER 3 MISFIRE DETECTED — S078521B39

NOTE:

For the diagnostic procedure, refer to DTC P0304. <Ref. to EN-180, DTC P0304 — CYLINDER 4 MISFIRE DETECTED —, Diagnostic Procedure with Diagnostic Trouble Code (DTC).>

DIAGNOSTIC PROCEDURE WITH DIAGNOSTIC TROUBLE CODE (DTC)

Engine (Diagnostics)

AJ: DTC P0304 — CYLINDER 4 MISFIRE DETECTED — S078521B40

- **DTC DETECTING CONDITION:**

- Two consecutive driving cycles with fault
- Immediately at fault recognition (A misfire which could damage catalyst occurs.)

- **TROUBLE SYMPTOM:**

- Engine stalls.
- Erroneous idling
- Rough driving

CAUTION:

After repair or replacement of faulty parts, conduct Clear Memory Mode <Ref. to EN-55, OPERATION, Clear Memory Mode.> and Inspection Mode <Ref. to EN-48, OPERATION, Inspection Mode.>.

DIAGNOSTIC PROCEDURE WITH DIAGNOSTIC TROUBLE CODE (DTC)

Engine (Diagnostics)

● WIRING DIAGRAM:

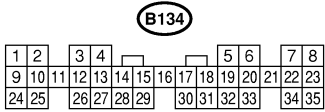
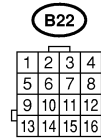
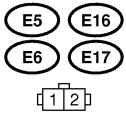
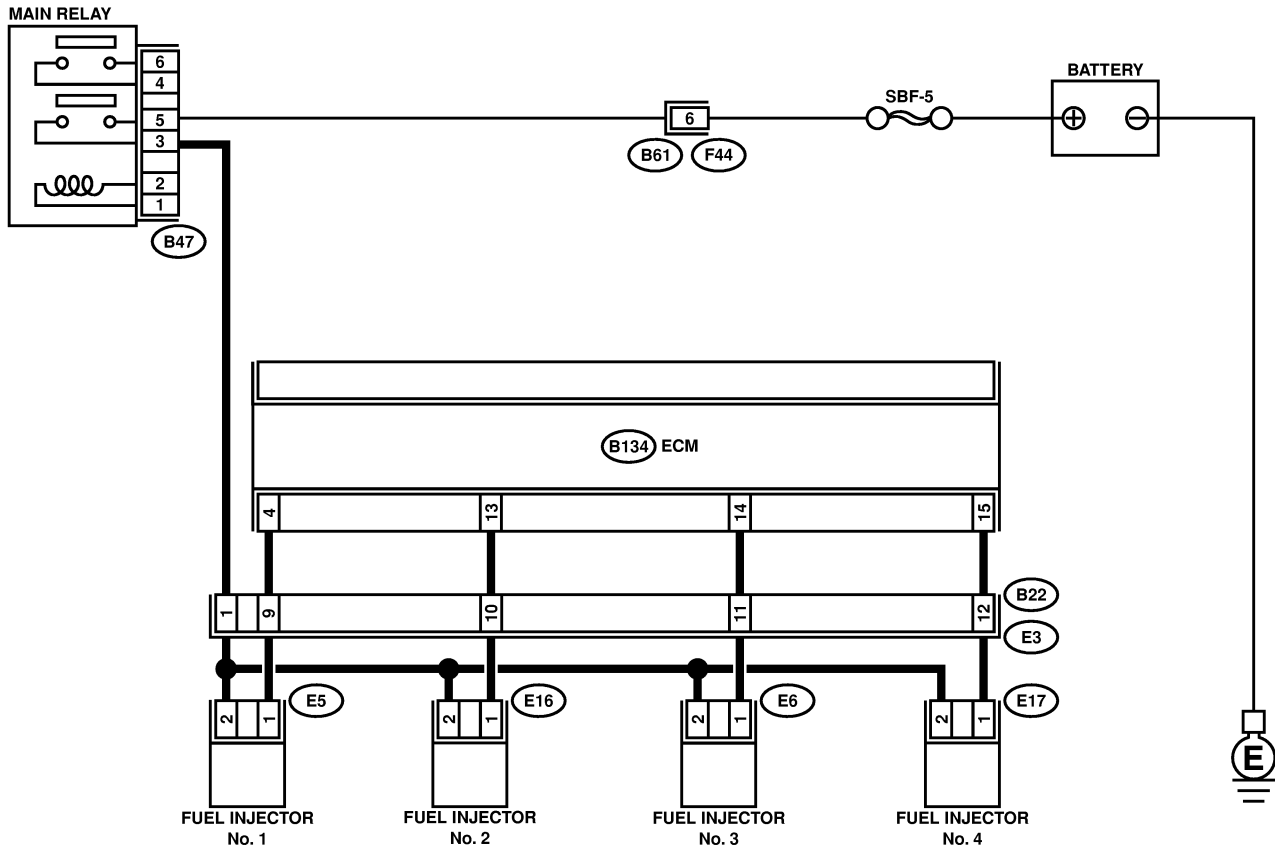

B2M4638

DIAGNOSTIC PROCEDURE WITH DIAGNOSTIC TROUBLE CODE (DTC)

Engine (Diagnostics)

No.	Step	Check	Yes	No
1	CHECK ANY OTHER DTC ON DISPLAY.	Is any other DTC displayed?	Inspect the relevant DTC using "List of Diagnostic Trouble Code (DTC)". <Ref. to EN-88, List of Diagnostic Trouble Code (DTC).> NOTE: In this case, it is not necessary to inspect DTC P0301, P0302, P0303 and P0304.	Go to step 2.
2	CHECK OUTPUT SIGNAL FROM ECM. 1) Turn ignition switch to ON. 2) Measure voltage between ECM connector and chassis ground on faulty cylinders. Connector & terminal #1 (B134) No. 4 (+) — Chassis ground (-): #2 (B134) No. 13 (+) — Chassis ground (-): #3 (B134) No. 14 (+) — Chassis ground (-): #4 (B134) No. 15 (+) — Chassis ground (-):	Is the voltage more than 10 V?	Go to step 7.	Go to step 3.
3	CHECK HARNESS BETWEEN FUEL INJECTOR AND ECM CONNECTOR. 1) Turn ignition switch to OFF. 2) Disconnect connector from fuel injector on faulty cylinders. 3) Measure voltage between ECM connector and engine ground on faulty cylinders. Connector & terminal #1 (E5) No. 1 — Engine ground: #2 (E16) No. 1 — Engine ground: #3 (E6) No. 1 — Engine ground: #4 (E17) No. 1 — Engine ground:	Is the resistance less than 10 Ω?	Repair ground short circuit in harness between fuel injector and ECM connector.	Go to step 4.
4	CHECK HARNESS BETWEEN FUEL INJECTOR AND ECM CONNECTOR. Measure resistance of harness connector between ECM connector and fuel injector on faulty cylinders. Connector & terminal #1 (B134) No. 4 — (E5) No. 1: #2 (B134) No. 13 — (E16) No. 1: #3 (B134) No. 14 — (E6) No. 1: #4 (B134) No. 15 — (E17) No. 1:	Is the resistance less than 1 Ω?	Go to step 5.	Repair harness and connector. NOTE: In this case, repair the following: ● Open circuit in harness between ECM and fuel injector connector ● Poor contact in coupling connector
5	CHECK FUEL INJECTOR. Measure resistance between fuel injector terminals on faulty cylinder. Terminals No. 1 — No. 2:	Is the resistance between 5 and 20 Ω?	Go to step 6.	Replace faulty fuel injector. <Ref. to FU-41, Fuel Injector.>

DIAGNOSTIC PROCEDURE WITH DIAGNOSTIC TROUBLE CODE (DTC)

Engine (Diagnostics)

No.	Step	Check	Yes	No
6	<p>CHECK POWER SUPPLY LINE. 1) Turn ignition switch to ON. 2) Measure voltage between fuel injector and engine ground on faulty cylinders. Connector & terminal <i>#1 (E5) No. 2 (+) — Engine ground (-):</i> <i>#2 (E16) No. 2 (+) — Engine ground (-):</i> <i>#3 (E6) No. 2 (+) — Engine ground (-):</i> <i>#4 (E17) No. 2 (+) — Engine ground (-):</i></p>	Is the voltage more than 10 V?	Repair poor contact in all connectors in fuel injector circuit.	Repair harness and connector. NOTE: In this case, repair the following: <ul style="list-style-type: none"> ● Open circuit in harness between main relay and fuel injector connector on faulty cylinders ● Poor contact in coupling connector ● Poor contact in main relay connector ● Poor contact in fuel injector connector on faulty cylinders
7	<p>CHECK HARNESS BETWEEN FUEL INJECTOR AND ECM CONNECTOR. 1) Turn ignition switch to OFF. 2) Disconnect connector from fuel injector on faulty cylinder. 3) Turn ignition switch to ON. 4) Measure voltage between ECM connector and chassis ground on faulty cylinders. Connector & terminal <i>#1 (B134) No. 4 (+) — Chassis ground (-):</i> <i>#2 (B134) No. 13 (+) — Chassis ground (-):</i> <i>#3 (B134) No. 14 (+) — Chassis ground (-):</i> <i>#4 (B134) No. 15 (+) — Chassis ground (-):</i></p>	Is the voltage more than 10 V?	Repair battery short circuit in harness between ECM and fuel injector. After repair, replace ECM. <Ref. to FU-51, Engine Control Module.>	Go to step 8.
8	<p>CHECK FUEL INJECTOR. 1) Turn ignition switch to OFF. 2) Measure resistance between fuel injector terminals on faulty cylinder. Terminals <i>No. 1 — No. 2:</i></p>	Is the resistance less than 1 Ω?	Replace faulty fuel injector <Ref. to FU-41, Fuel Injector.> and ECM <Ref. to FU-51, Engine Control Module.>.	Go to step 9.
9	<p>CHECK INSTALLATION OF CAMSHAFT POSITION SENSOR/CRANKSHAFT POSITION SENSOR.</p>	Is camshaft position sensor or crankshaft position sensor loosely installed?	Tighten camshaft position sensor or crankshaft position sensor.	Go to step 10.
10	<p>CHECK CRANKSHAFT SPROCKET. Remove timing belt cover.</p>	Is crankshaft sprocket rusted or does it have broken teeth?	Replace crankshaft sprocket. <Ref. to ME-52, Crankshaft Sprocket.>	Go to step 11.

DIAGNOSTIC PROCEDURE WITH DIAGNOSTIC TROUBLE CODE (DTC)

Engine (Diagnostics)

No.	Step	Check	Yes	No
11	CHECK INSTALLATION CONDITION OF TIMING BELT. Turn crankshaft using ST, and align alignment mark on crankshaft sprocket with alignment mark on cylinder block. ST 499987500 CRANKSHAFT SOCKET	Is timing belt dislocated from its proper position?	Repair installation condition of timing belt. <Ref. to ME-46, Timing Belt Assembly.>	Go to step 12.
12	CHECK FUEL LEVEL.	Is the fuel meter indication higher than the "Lower" level?	Go to step 13.	Replenish fuel so fuel meter indication is higher than the "Lower" level. After replenishing fuel, Go to step 13.
13	CHECK STATUS OF CHECK ENGINE MALFUNCTION INDICATOR LAMP (MIL). 1) Clear memory using Subaru Select Monitor. <Ref. to EN-55, Clear Memory Mode.> 2) Start engine, and drive the vehicle more than 10 minutes.	Is the MIL coming on or blinking?	Go to step 15.	Go to step 14.
14	CHECK CAUSE OF MISFIRE DIAGNOSED.	Was the cause of misfire diagnosed when the engine is running?	Finish diagnostics operation, if the engine has no abnormality. NOTE: Ex. Remove spark plug cord, etc.	Repair poor contact. NOTE: In this case, repair the following: <ul style="list-style-type: none"> ● Poor contact in ignitor connector ● Poor contact in ignition coil connector ● Poor contact in fuel injector connector on faulty cylinders ● Poor contact in ECM connector ● Poor contact in coupling connector
15	CHECK AIR INTAKE SYSTEM.	Is there a fault in air intake system?	Repair air intake system. NOTE: Check the following items: <ul style="list-style-type: none"> ● Are there air leaks or air suction caused by loose or dislocated nuts and bolts? ● Are there cracks or any disconnection of hoses? 	Go to step 16.

DIAGNOSTIC PROCEDURE WITH DIAGNOSTIC TROUBLE CODE (DTC)

Engine (Diagnostics)

No.	Step	Check	Yes	No
16	<p>CHECK MISFIRE SYMPTOM.</p> <p>1) Turn ignition switch to ON. 2) Read diagnostic trouble code (DTC).</p> <ul style="list-style-type: none"> ● Subaru Select Monitor <p><Ref. to EN-36, Subaru Select Monitor.></p> <ul style="list-style-type: none"> ● OBD-II general scan tool <p>For detailed operation procedures, refer to the OBD-II General Scan Tool Operation Manual. NOTE: Perform diagnosis according to the items listed below.</p>	Does the Subaru Select Monitor or OBD-II general scan tool indicate only one DTC?	Go to step 21.	Go to step 17.
17	<p>CHECK DIAGNOSTIC TROUBLE CODE (DTC) ON DISPLAY.</p>	Does the Subaru Select Monitor or OBD-II general scan tool indicate DTC P0301 and P0302?	Go to step 22.	Go to step 18.
18	<p>CHECK DIAGNOSTIC TROUBLE CODE (DTC) ON DISPLAY.</p>	Does the Subaru Select Monitor or OBD-II general scan tool indicate DTC P0303 and P0304?	Go to step 23.	Go to step 19.
19	<p>CHECK DIAGNOSTIC TROUBLE CODE (DTC) ON DISPLAY.</p>	Does the Subaru Select Monitor or OBD-II general scan tool indicate DTC P0301 and P0303?	Go to step 24.	Go to step 20.
20	<p>CHECK DIAGNOSTIC TROUBLE CODE (DTC) ON DISPLAY.</p>	Does the Subaru Select Monitor or OBD-II general scan tool indicate DTC P0302 and P0304?	Go to step 25.	Go to step 26.
21	<p>ONLY ONE CYLINDER</p>	Is there a fault in that cylinder?	<p>Repair or replace faulty parts. NOTE: Check the following items.</p> <ul style="list-style-type: none"> ● Spark plug ● Spark plug cord ● Fuel injector ● Compression ratio 	Go to DTC P0171. <Ref. to EN-170, DTC P0171 — FUEL TRIM MALFUNCTION (A/F TOO LEAN) —, Diagnostic Procedure with Diagnostic Trouble Code (DTC).>
22	<p>GROUP OF #1 AND #2 CYLINDERS</p>	Are there faults in #1 and #2 cylinders?	<p>Repair or replace faulty parts. NOTE: Check the following items.</p> <p>Spark plugs Fuel injectors Ignition coil Compression ratio</p> <ul style="list-style-type: none"> ● If no abnormal is discovered, check for "IGNITION CONTROL SYSTEM" of #1 and #2 cylinders side. <Ref. to EN-78, IGNITION CONTROL SYSTEM, Diagnostics for Engine Starting Failure.> 	Go to DTC P0171. <Ref. to EN-170, DTC P0171 — FUEL TRIM MALFUNCTION (A/F TOO LEAN) —, Diagnostic Procedure with Diagnostic Trouble Code (DTC).>

DIAGNOSTIC PROCEDURE WITH DIAGNOSTIC TROUBLE CODE (DTC)

Engine (Diagnostics)

No.	Step	Check	Yes	No
23	GROUP OF #3 AND #4 CYLINDERS	Are there faults in #3 and #4 cylinders?	Repair or replace faulty parts. NOTE: ● Check the following items. Spark plugs Fuel injectors Ignition coil ● If no abnormal is discovered, check for "16. D: IGNITION CONTROL SYSTEM" of #3 and #4 cylinders side. <Ref. to EN-78, IGNITION CONTROL SYSTEM, Diagnostics for Engine Starting Failure.>	Go to DTC P0171. <Ref. to EN-170, DTC P0171 — FUEL TRIM MALFUNCTION (A/F TOO LEAN) —, Diagnostic Procedure with Diagnostic Trouble Code (DTC).>
24	GROUP OF #1 AND #3 CYLINDERS	Are there faults in #1 and #3 cylinders?	Repair or replace faulty parts. NOTE: Check the following items. ● Spark plugs ● Fuel injectors ● Skipping timing belt teeth	Go to DTC P0171. <Ref. to EN-170, DTC P0171 — FUEL TRIM MALFUNCTION (A/F TOO LEAN) —, Diagnostic Procedure with Diagnostic Trouble Code (DTC).>
25	GROUP OF #2 AND #4 CYLINDERS	Are there faults in #2 and #4 cylinders?	Repair or replace faulty parts. NOTE: Check the following items. ● Spark plugs ● Fuel injectors ● Compression ratio ● Skipping timing belt teeth	Go to DTC P0171. <Ref. to EN-170, DTC P0171 — FUEL TRIM MALFUNCTION (A/F TOO LEAN) —, Diagnostic Procedure with Diagnostic Trouble Code (DTC).>
26	CYLINDER AT RANDOM	Is the engine idle rough?	Go to DTC P0171. <Ref. to EN-170, DTC P0171 — FUEL TRIM MALFUNCTION (A/F TOO LEAN) —, Diagnostic Procedure with Diagnostic Trouble Code (DTC).>	Repair or replace faulty parts. NOTE: Check the following items. ● Spark plugs ● Fuel injectors ● Compression ratio

MEMO:

DIAGNOSTIC PROCEDURE WITH DIAGNOSTIC TROUBLE CODE (DTC)

Engine (Diagnostics)

AK: DTC P0327 — KNOCK SENSOR CIRCUIT LOW INPUT — S078521F94

- **DTC DETECTING CONDITION:**
 - Immediately at fault recognition
- **TROUBLE SYMPTOM:**
 - Poor driving performance
 - Knocking occurs.

CAUTION:

After repair or replacement of faulty parts, conduct Clear Memory Mode <Ref. to EN-55, OPERATION, Clear Memory Mode.> and Inspection Mode <Ref. to EN-48, OPERATION, Inspection Mode.>.

● WIRING DIAGRAM:

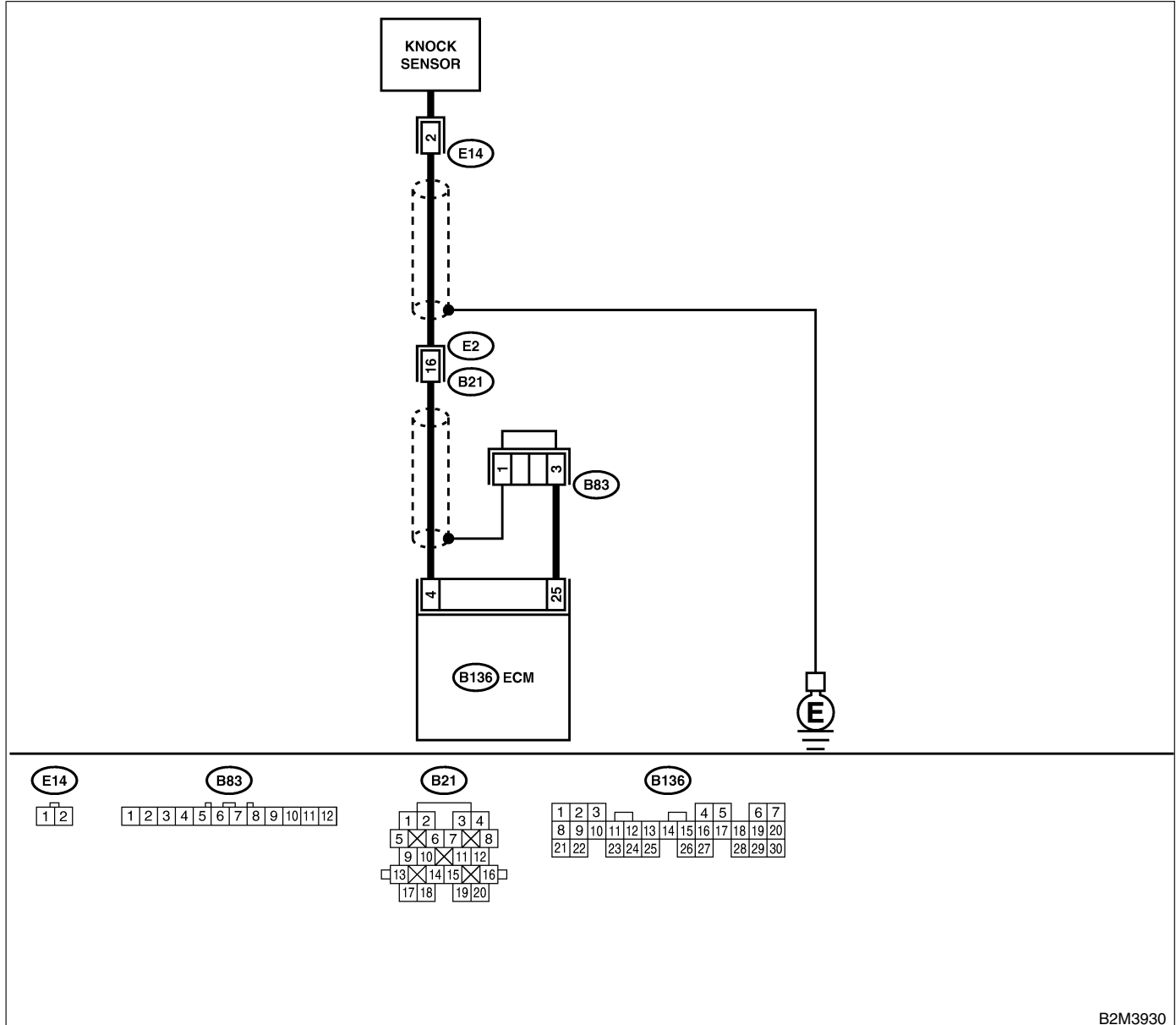

B2M3930

DIAGNOSTIC PROCEDURE WITH DIAGNOSTIC TROUBLE CODE (DTC)

Engine (Diagnostics)

No.	Step	Check	Yes	No
1	<p>CHECK HARNESS BETWEEN KNOCK SENSOR AND ECM CONNECTOR.</p> <p>1) Turn ignition switch to OFF. 2) Disconnect connector from ECM. 3) Measure resistance between ECM harness connector and chassis ground.</p> <p>Connector & terminal (B136) No. 4 — Chassis ground:</p>	Is the resistance more than 700 kΩ?	Go to step 2.	Repair harness and connector. NOTE: In this case, repair the following: <ul style="list-style-type: none"> ● Open circuit in harness between knock sensor and ECM connector ● Poor contact in knock sensor connector ● Poor contact in coupling connector
2	<p>CHECK KNOCK SENSOR.</p> <p>1) Disconnect connector from knock sensor. 2) Measure resistance between knock sensor connector terminal and engine ground.</p> <p>Terminal No. 2 — Engine ground:</p>	Is the resistance more than 700 kΩ?	Go to step 3.	Repair harness and connector. NOTE: In this case, repair the following: <ul style="list-style-type: none"> ● Open circuit in harness between knock sensor and ECM connector ● Poor contact in knock sensor connector ● Poor contact in coupling connector
3	<p>CHECK CONDITION OF KNOCK SENSOR INSTALLATION.</p>	Is the knock sensor installation bolt tightened securely?	Replace knock sensor. <Ref. to FU-33, Knock Sensor.>	Tighten knock sensor installation bolt securely.

DIAGNOSTIC PROCEDURE WITH DIAGNOSTIC TROUBLE CODE (DTC)

Engine (Diagnostics)

AL: DTC P0328 — KNOCK SENSOR CIRCUIT HIGH INPUT — S078521F95

- **DTC DETECTING CONDITION:**
 - Immediately at fault recognition
- **TROUBLE SYMPTOM:**
 - Poor driving performance
 - Knocking occurs.

CAUTION:

After repair or replacement of faulty parts, conduct Clear Memory Mode <Ref. to EN-55, OPERATION, Clear Memory Mode.> and Inspection Mode <Ref. to EN-48, OPERATION, Inspection Mode.>.

● WIRING DIAGRAM:

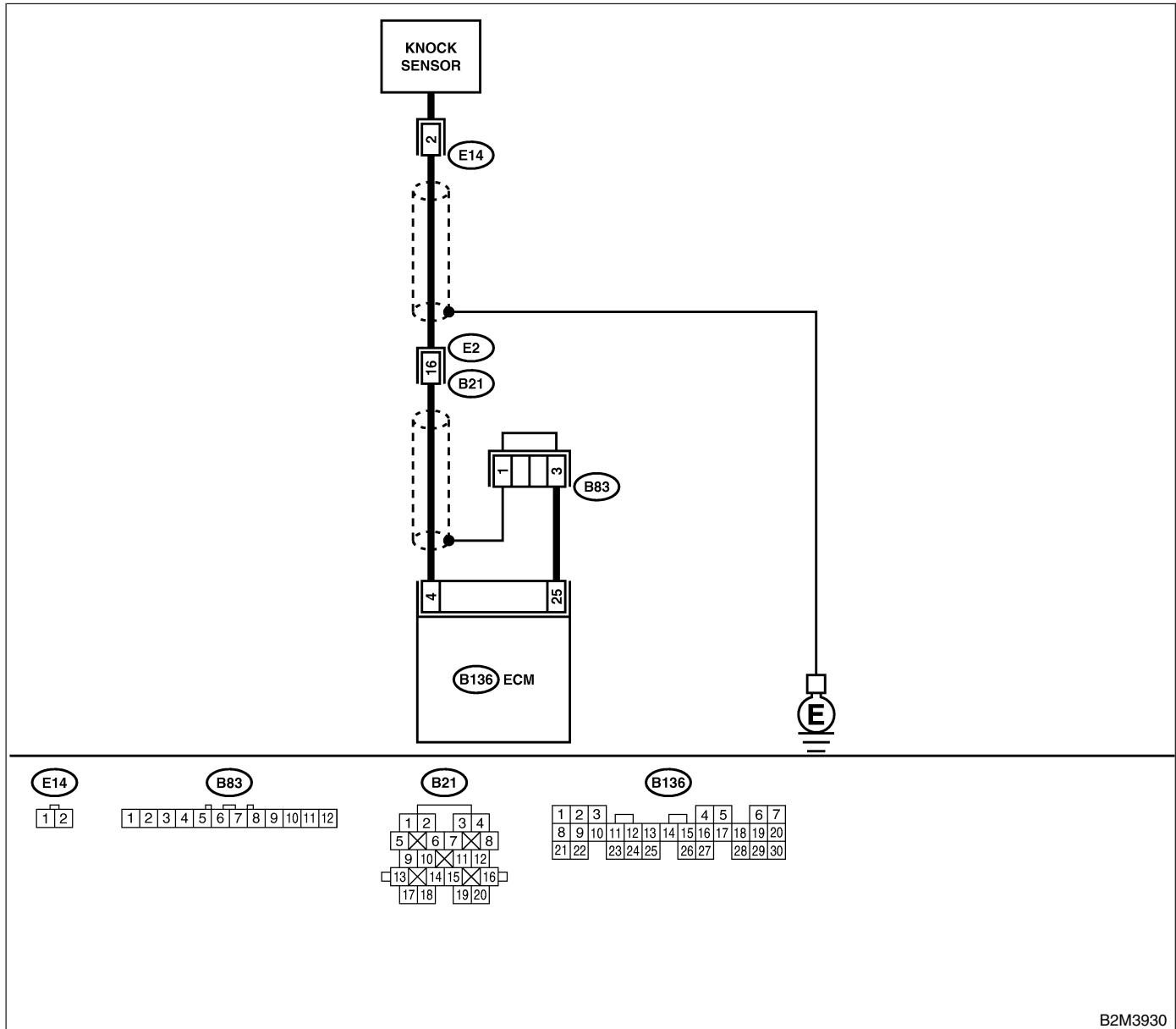

B2M3930

DIAGNOSTIC PROCEDURE WITH DIAGNOSTIC TROUBLE CODE (DTC)

Engine (Diagnostics)

No.	Step	Check	Yes	No
1	<p>CHECK HARNESS BETWEEN KNOCK SENSOR AND ECM CONNECTOR. Measure resistance of harness between ECM connector and chassis ground. Connector & terminal (B136) No. 4 — Chassis ground:</p>	Is the resistance less than 400 kΩ?	Go to step 2.	Go to step 3.
2	<p>CHECK KNOCK SENSOR. 1) Disconnect connector from knock sensor. 2) Measure resistance between knock sensor connector terminal and engine ground. Terminal No. 2 — Engine ground:</p>	Is the resistance less than 400 kΩ?	Replace knock sensor. <Ref. to FU-33, Knock Sensor.>	Repair ground short circuit in harness between knock sensor connector and ECM connector. NOTE: The harness between both connectors is shielded. Repair short circuit of harness together with shield.
3	<p>CHECK INPUT SIGNAL FOR ECM. 1) Connect connectors to ECM and knock sensor. 2) Turn ignition switch to ON. 3) Measure voltage between ECM and chassis ground. Connector & terminal (B136) No. 4 (+) — Chassis ground (-):</p>	Is the voltage more than 2 V?	Even if MIL lights up, the circuit has returned to a normal condition at this time. (However, the possibility of poor contact still remains.) NOTE: In this case, repair the following: <ul style="list-style-type: none"> ● Poor contact in knock sensor connector ● Poor contact in ECM connector ● Poor contact in coupling connector 	Repair poor contact in ECM connector.

DIAGNOSTIC PROCEDURE WITH DIAGNOSTIC TROUBLE CODE (DTC)

Engine (Diagnostics)

AM: DTC P0335 — CRANKSHAFT POSITION SENSOR CIRCUIT MALFUNCTION — S078521B42

- **DTC DETECTING CONDITION:**
 - Immediately at fault recognition
- **TROUBLE SYMPTOM:**
 - Engine stalls.
 - Failure of engine to start

CAUTION:

After repair or replacement of faulty parts, conduct Clear Memory Mode <Ref. to EN-55, OPERATION, Clear Memory Mode.> and Inspection Mode <Ref. to EN-48, OPERATION, Inspection Mode.>.

● WIRING DIAGRAM:

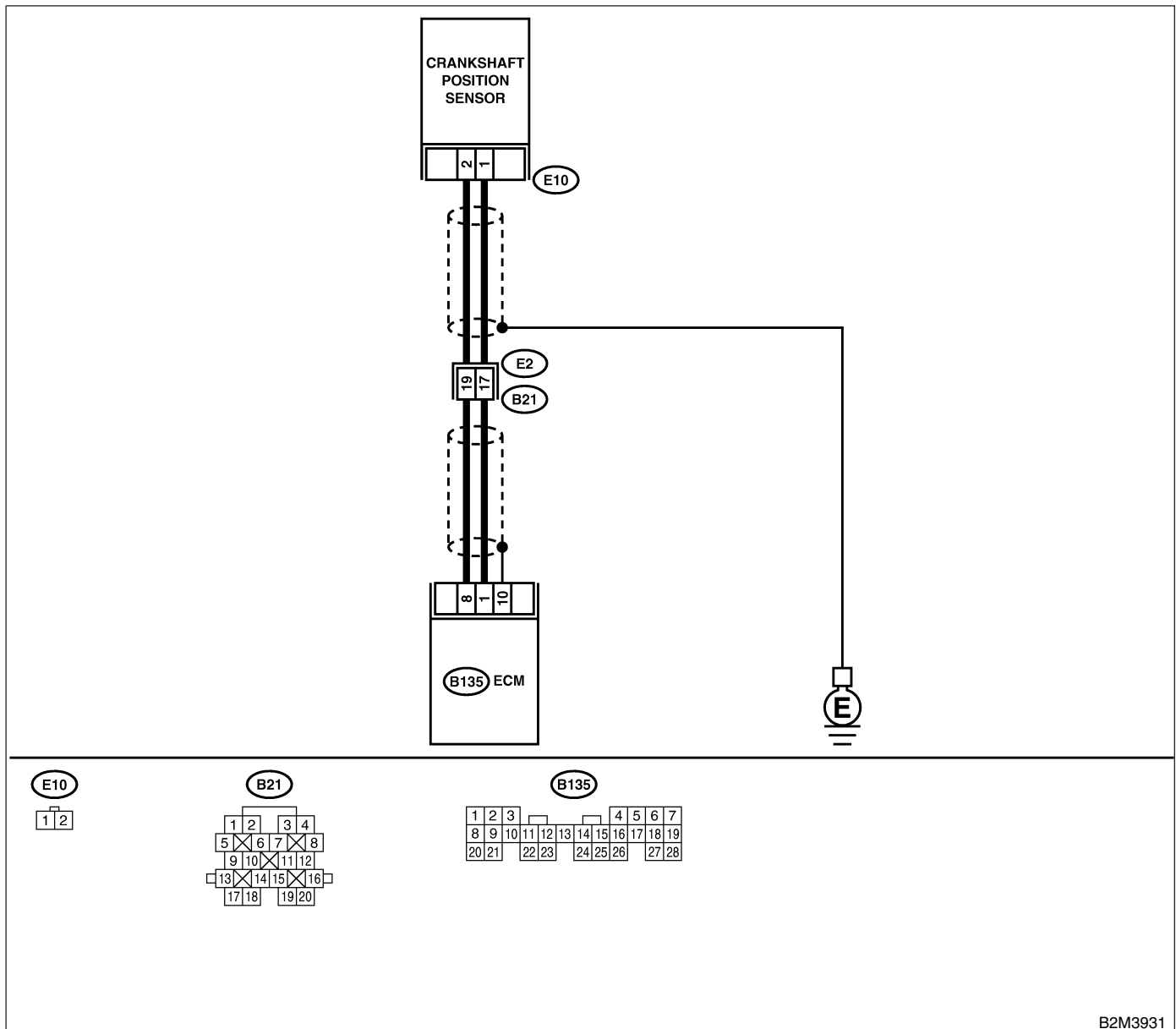

B2M3931

DIAGNOSTIC PROCEDURE WITH DIAGNOSTIC TROUBLE CODE (DTC)

Engine (Diagnostics)

No.	Step	Check	Yes	No
1	<p>CHECK HARNESS BETWEEN CRANKSHAFT POSITION SENSOR AND ECM CONNECTOR.</p> <p>1) Turn ignition switch to OFF. 2) Disconnect connector from crankshaft position sensor. 3) Measure resistance of harness between crankshaft position sensor connector and engine ground.</p> <p>Connector & terminal (E10) No. 1 — Engine ground:</p>	Is the resistance more than 100 k Ω ?	<p>Repair harness and connector.</p> <p>NOTE: In this case, repair the following:</p> <ul style="list-style-type: none"> ● Open circuit in harness between crankshaft position sensor and ECM connector ● Poor contact in ECM connector ● Poor contact in coupling connector 	Go to step 2.
2	<p>CHECK HARNESS BETWEEN CRANKSHAFT POSITION SENSOR AND ECM CONNECTOR.</p> <p>Measure resistance of harness between crankshaft position sensor connector and engine ground.</p> <p>Connector & terminal (E10) No. 1 — Engine ground:</p>	Is the resistance less than 10 Ω ?	<p>Repair ground short circuit in harness between crankshaft position sensor and ECM connector.</p> <p>NOTE: The harness between both connectors are shielded. Repair ground short circuit in harness together with shield.</p>	Go to step 3.
3	<p>CHECK HARNESS BETWEEN CRANKSHAFT POSITION SENSOR AND ECM CONNECTOR.</p> <p>Measure resistance of harness between crankshaft position sensor connector and engine ground.</p> <p>Connector & terminal (E10) No. 2 — Engine ground:</p>	Is the resistance less than 5 Ω ?	Go to step 4.	<p>Repair harness and connector.</p> <p>NOTE: In this case, repair the following:</p> <ul style="list-style-type: none"> ● Open circuit in harness between crankshaft position sensor and ECM connector ● Poor contact in ECM connector ● Poor contact in coupling connector
4	<p>CHECK CONDITION OF CRANKSHAFT POSITION SENSOR.</p>	Is the crankshaft position sensor installation bolt tightened securely?	Go to step 5.	Tighten crankshaft position sensor installation bolt securely.
5	<p>CHECK CRANKSHAFT POSITION SENSOR.</p> <p>1) Remove crankshaft position sensor. 2) Measure resistance between connector terminals of crankshaft position sensor.</p> <p>Terminals No. 1 — No. 2:</p>	Is the resistance between 1 and 4 k Ω ?	Repair poor contact in crankshaft position sensor connector.	Replace crankshaft position sensor. <Ref. to FU-31, Crankshaft Position Sensor.>

DIAGNOSTIC PROCEDURE WITH DIAGNOSTIC TROUBLE CODE (DTC)

Engine (Diagnostics)

AN: DTC P0336 — CRANKSHAFT POSITION SENSOR CIRCUIT RANGE/PERFORMANCE PROBLEM — S078521B43

- **DTC DETECTING CONDITION:**
 - Immediately at fault recognition
- **TROUBLE SYMPTOM:**
 - Engine stalls.
 - Failure of engine to start

CAUTION:

After repair or replacement of faulty parts, conduct Clear Memory Mode <Ref. to EN-55, OPERATION, Clear Memory Mode.> and Inspection Mode <Ref. to EN-48, OPERATION, Inspection Mode.>.

- **WIRING DIAGRAM:**

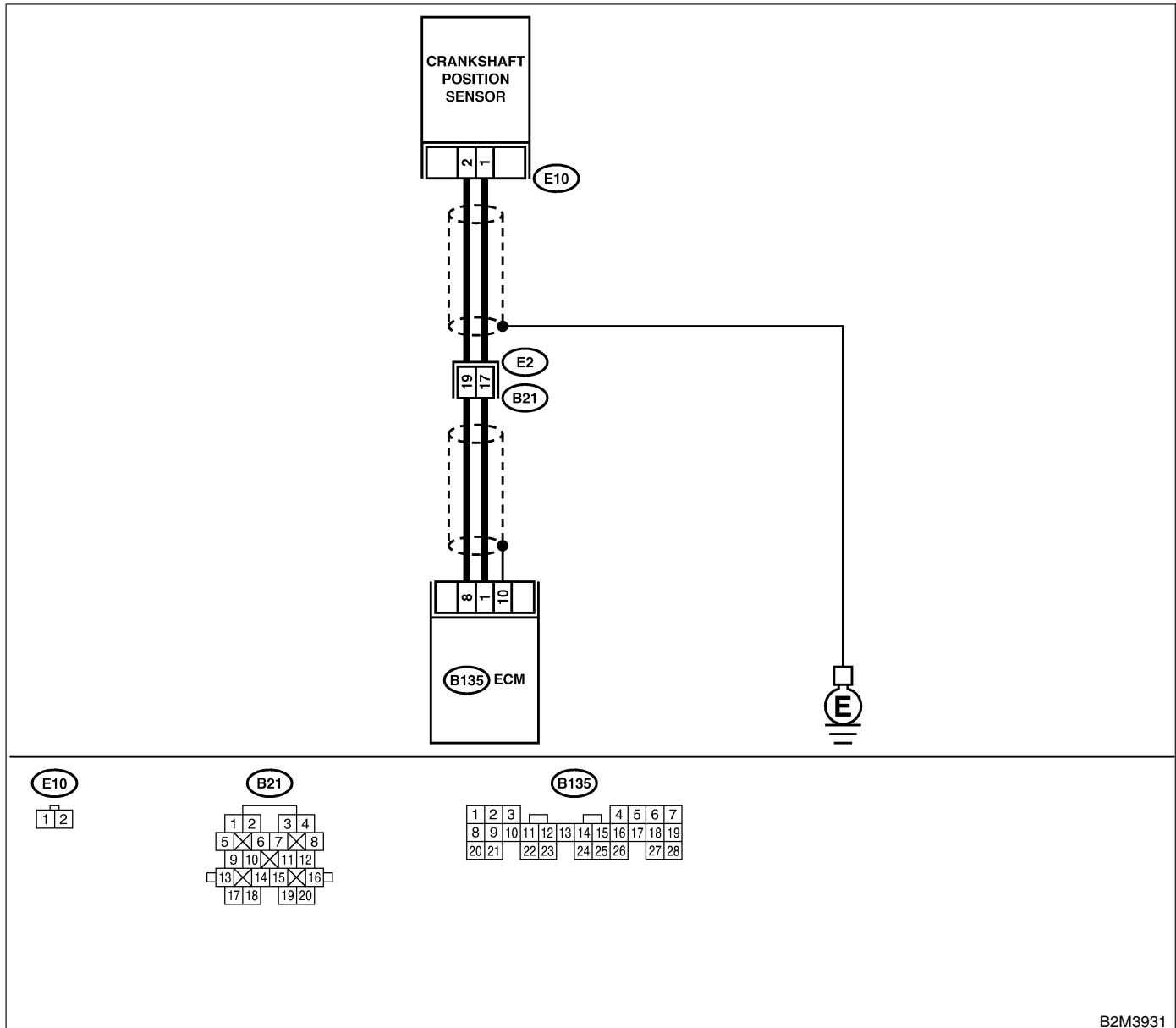

B2M3931

DIAGNOSTIC PROCEDURE WITH DIAGNOSTIC TROUBLE CODE (DTC)

Engine (Diagnostics)

No.	Step	Check	Yes	No
1	CHECK ANY OTHER DTC ON DISPLAY.	Does the Subaru Select Monitor or OBD-II general scan tool indicate DTC P0335?	Inspect DTC P0335 using "List of Diagnostic Trouble Code (DTC)". <Ref. to EN-88, List of Diagnostic Trouble Code (DTC).>	Go to step 2.
2	CHECK CONDITION OF CRANKSHAFT POSITION SENSOR. Turn ignition switch to OFF.	Is the crankshaft position sensor installation bolt tightened securely?	Go to step 3.	Tighten crankshaft position sensor installation bolt securely.
3	CHECK CRANKSHAFT SPROCKET. Remove front belt cover.	Are crankshaft sprocket teeth cracked or damaged?	Replace crankshaft sprocket. <Ref. to ME-52, Crankshaft Sprocket.>	Go to step 4.
4	CHECK INSTALLATION CONDITION OF TIMING BELT. Turn crankshaft using ST, and align alignment mark on crankshaft sprocket with alignment mark on cylinder block. ST 499987500 CRANKSHAFT SOCKET	Is timing belt dislocated from its proper position?	Repair installation condition of timing belt. <Ref. to ME-46, Timing Belt Assembly.>	Replace crankshaft position sensor. <Ref. to FU-52, Crankshaft Position Sensor.>

DIAGNOSTIC PROCEDURE WITH DIAGNOSTIC TROUBLE CODE (DTC)

Engine (Diagnostics)

AO: DTC P0340 — CAMSHAFT POSITION SENSOR CIRCUIT MALFUNCTION

S078521B44

- **DTC DETECTING CONDITION:**
 - Immediately at fault recognition
- **TROUBLE SYMPTOM:**
 - Engine stalls.
 - Failure of engine to start

CAUTION:

After repair or replacement of faulty parts, conduct Clear Memory Mode <Ref. to EN-55, OPERATION, Clear Memory Mode.> and Inspection Mode <Ref. to EN-48, OPERATION, Inspection Mode.>.

● WIRING DIAGRAM:

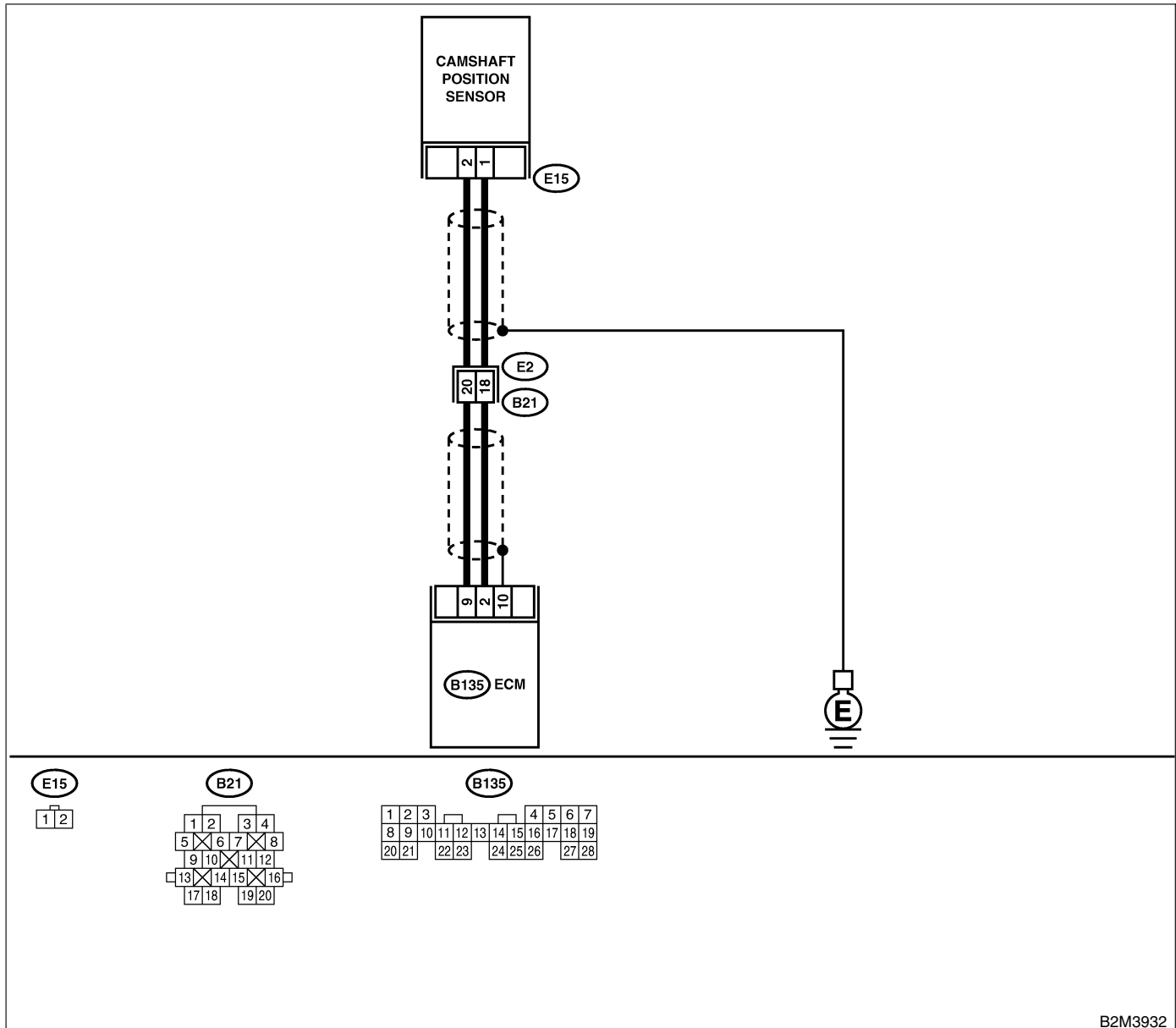

B2M3932

DIAGNOSTIC PROCEDURE WITH DIAGNOSTIC TROUBLE CODE (DTC)

Engine (Diagnostics)

No.	Step	Check	Yes	No
1	<p>CHECK HARNESS BETWEEN CAMSHAFT POSITION SENSOR AND ECM CONNECTOR.</p> <p>1) Turn ignition switch to OFF. 2) Disconnect connector from camshaft position sensor. 3) Measure resistance of harness between camshaft position sensor connector and engine ground.</p> <p>Connector & terminal (E15) No. 1 — Engine ground:</p>	Is the resistance more than 100 k Ω ?	<p>Repair harness and connector.</p> <p>NOTE: In this case, repair the following:</p> <ul style="list-style-type: none"> ● Open circuit in harness between camshaft position sensor and ECM connector ● Poor contact in ECM connector ● Poor contact in coupling connector 	Go to step 2.
2	<p>CHECK HARNESS BETWEEN CAMSHAFT POSITION SENSOR AND ECM CONNECTOR.</p> <p>Measure resistance of harness between camshaft position sensor connector and engine ground.</p> <p>Connector & terminal (E15) No. 1 — Engine ground:</p>	Is the resistance less than 10 Ω ?	<p>Repair ground short circuit in harness between camshaft position sensor and ECM connector.</p> <p>NOTE: The harness between both connectors are shielded. Repair ground short circuit in harness together with shield.</p>	Go to step 3.
3	<p>CHECK HARNESS BETWEEN CAMSHAFT POSITION SENSOR AND ECM CONNECTOR.</p> <p>Measure resistance of harness between camshaft position sensor connector and engine ground.</p> <p>Connector & terminal (E15) No. 2 — Engine ground:</p>	Is the resistance less than 5 Ω ?	Go to step 4.	<p>Repair harness and connector.</p> <p>NOTE: In this case, repair the following:</p> <ul style="list-style-type: none"> ● Open circuit in harness between camshaft position sensor and ECM connector ● Poor contact in ECM connector ● Poor contact in coupling connector
4	<p>CHECK CONDITION OF CAMSHAFT POSITION SENSOR.</p>	Is the camshaft position sensor installation bolt tightened securely?	Go to step 5.	Tighten camshaft position sensor installation bolt securely.
5	<p>CHECK CAMSHAFT POSITION SENSOR.</p> <p>1) Remove camshaft position sensor. 2) Measure resistance between connector terminals of camshaft position sensor.</p> <p>Terminals No. 1 — No. 2:</p>	Is the resistance between 1 and 4 k Ω ?	Repair poor contact in camshaft position sensor connector.	Replace camshaft position sensor. <Ref. to FU-32, Camshaft Position Sensor.>

DIAGNOSTIC PROCEDURE WITH DIAGNOSTIC TROUBLE CODE (DTC)

Engine (Diagnostics)

AP: DTC P0341 — CAMSHAFT POSITION SENSOR CIRCUIT RANGE/PERFORMANCE PROBLEM —

S078521B45

- **DTC DETECTING CONDITION:**
 - Immediately at fault recognition
- **TROUBLE SYMPTOM:**
 - Engine stalls.
 - Failure of engine to start

CAUTION:

After repair or replacement of faulty parts, conduct Clear Memory Mode <Ref. to EN-55, OPERATION, Clear Memory Mode.> and Inspection Mode <Ref. to EN-48, OPERATION, Inspection Mode.>.

● WIRING DIAGRAM:

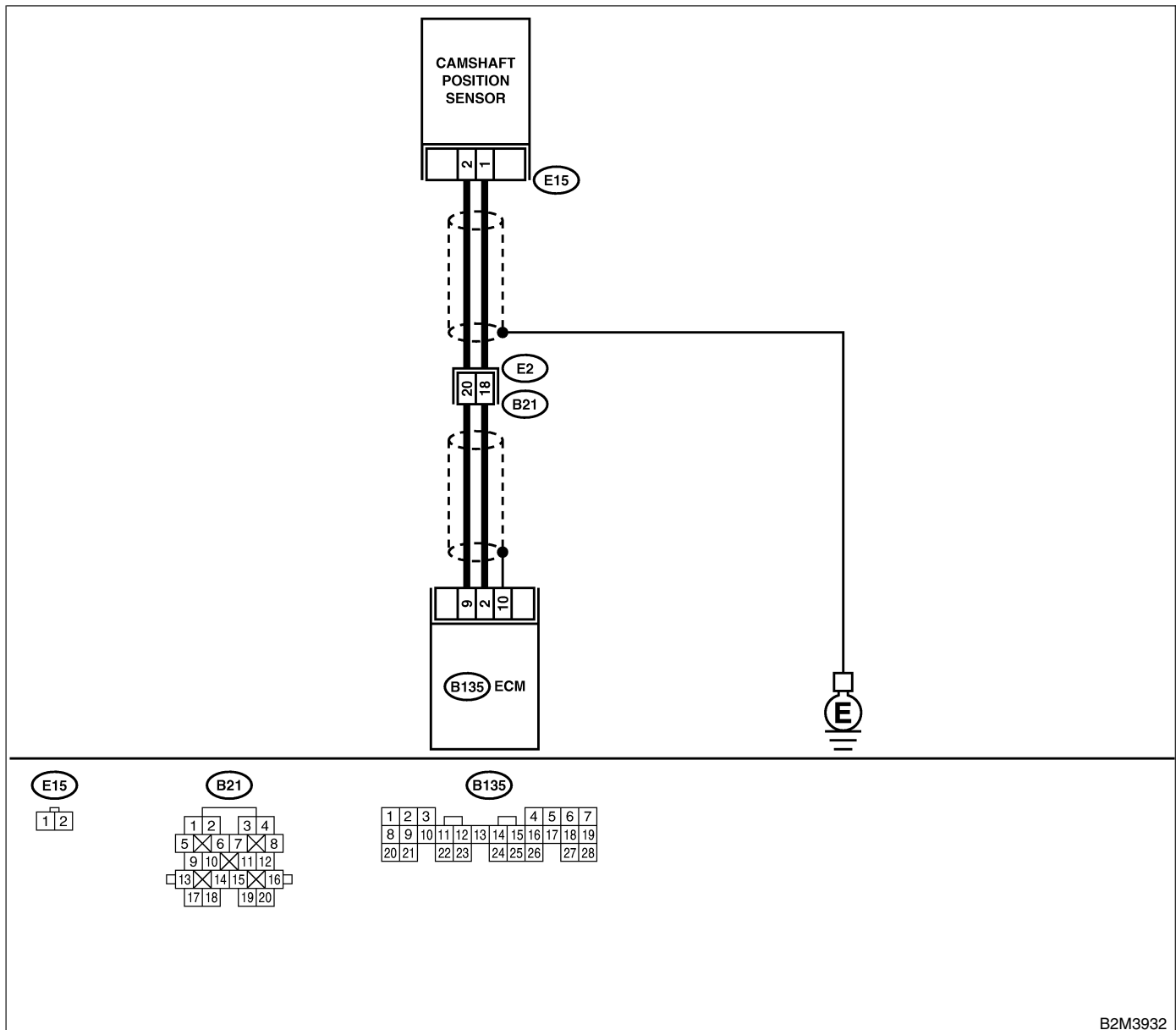

B2M3932

DIAGNOSTIC PROCEDURE WITH DIAGNOSTIC TROUBLE CODE (DTC)

Engine (Diagnostics)

No.	Step	Check	Yes	No
1	CHECK ANY OTHER DTC ON DISPLAY.	Does the Subaru Select Monitor or OBD-II general scan tool indicate DTC P0340?	Inspect DTC P0340 using "List of Diagnostic Trouble Code (DTC)". <Ref. to EN-88, List of Diagnostic Trouble Code (DTC).>	Go to step 2.
2	CHECK HARNESS BETWEEN CAMSHAFT POSITION SENSOR AND ECM CONNECTOR. 1) Turn ignition switch to OFF. 2) Disconnect connector from camshaft position sensor. 3) Measure resistance of harness between camshaft position sensor connector and engine ground. Connector & terminal (E15) No. 1 — Engine ground:	Is the resistance more than 100 kΩ?	Repair harness and connector. NOTE: In this case, repair the following: ● Open circuit in harness between camshaft position sensor and ECM connector ● Poor contact in ECM connector ● Poor contact in coupling connector	Go to step 3.
3	CHECK HARNESS BETWEEN CAMSHAFT POSITION SENSOR AND ECM CONNECTOR. Measure resistance of harness between camshaft position sensor connector and engine ground. Connector & terminal (E15) No. 1 — Engine ground:	Is the resistance less than 10 Ω?	Repair ground short circuit in harness between camshaft position sensor and ECM connector. NOTE: The harness between both connectors are shielded. Repair ground short circuit in harness together with shield.	Go to step 4.
4	CHECK HARNESS BETWEEN CAMSHAFT POSITION SENSOR AND ECM CONNECTOR. Measure resistance of harness between camshaft position sensor connector and engine ground. Connector & terminal (E15) No. 2 — Engine ground:	Is the resistance less than 5 Ω?	Go to step 5.	Repair harness and connector. NOTE: In this case, repair the following: ● Open circuit in harness between camshaft position sensor and ECM connector ● Poor contact in ECM connector ● Poor contact in coupling connector
5	CHECK CONDITION OF CAMSHAFT POSITION SENSOR.	Is the camshaft position sensor installation bolt tightened securely?	Go to step 6.	Tighten camshaft position sensor installation bolt securely.

DIAGNOSTIC PROCEDURE WITH DIAGNOSTIC TROUBLE CODE (DTC)

Engine (Diagnostics)

No.	Step	Check	Yes	No
6	CHECK CAMSHAFT POSITION SENSOR. 1) Remove camshaft position sensor. 2) Measure resistance between connector terminals of camshaft position sensor. <i>Terminals</i> <i>No. 1 — No. 2:</i>	Is the resistance between 1 and 4 kΩ?	Go to step 7.	Replace camshaft position sensor. <Ref. to FU-32, Camshaft Position Sensor.>
7	CHECK CONDITION OF CAMSHAFT POSITION SENSOR. Turn ignition switch to OFF.	Is the camshaft position sensor installation bolt tightened securely?	Go to step 8.	Tighten camshaft position sensor installation bolt securely.
8	CHECK CAMSHAFT SPROCKET. Remove front belt cover. <Ref. to ME-45, Belt Cover.>	Are camshaft sprocket teeth cracked or damaged?	Replace camshaft sprocket. <Ref. to ME-51, Camshaft Sprocket.>	Go to step 9.
9	CHECK INSTALLATION CONDITION OF TIMING BELT. Turn camshaft using ST, and align alignment mark on camshaft sprocket with alignment mark on timing belt cover LH. ST 499207100 CAMSHAFT SPROCKET WRENCH	Is timing belt dislocated from its proper position?	Repair installation condition of timing belt. <Ref. to ME-46, Timing Belt Assembly.>	Replace camshaft position sensor. <Ref. to FU-32, Camshaft Position Sensor.>

MEMO:

DIAGNOSTIC PROCEDURE WITH DIAGNOSTIC TROUBLE CODE (DTC)

Engine (Diagnostics)

AQ: DTC P0420 — CATALYST SYSTEM EFFICIENCY BELOW THRESHOLD

S078521B46

• DTC DETECTING CONDITION:

- Two consecutive driving cycles with fault

• TROUBLE SYMPTOM:

- Engine stalls.
- Idle mixture is out of specifications.

CAUTION:

After repair or replacement of faulty parts, conduct Clear Memory Mode <Ref. to EN-55, OPERATION, Clear Memory Mode.> and Inspection Mode <Ref. to EN-48, OPERATION, Inspection Mode.>.

• WIRING DIAGRAM:

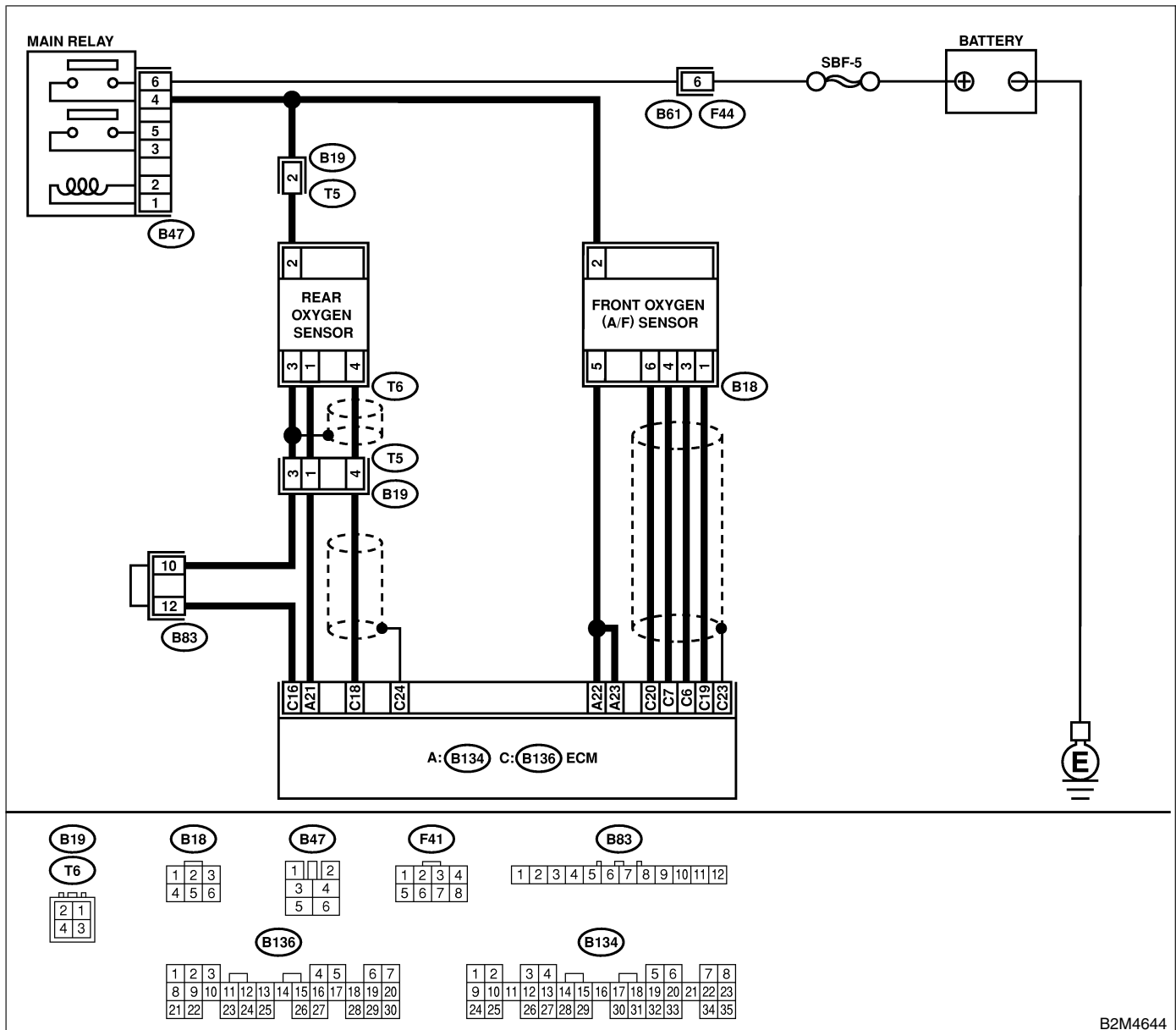

B2M4644

DIAGNOSTIC PROCEDURE WITH DIAGNOSTIC TROUBLE CODE (DTC)

Engine (Diagnostics)

No.	Step	Check	Yes	No
1	CHECK ANY OTHER DTC ON DISPLAY.	Is any other DTC displayed?	Inspect the relevant DTC using "List of Diagnostic Trouble Code (DTC)". <Ref. to EN-88, List of Diagnostic Trouble Code (DTC).> NOTE: In this case, it is not necessary to inspect DTC P0420.	Go to step 2.
2	CHECK EXHAUST SYSTEM. Check for gas leaks or air suction caused by loose or dislocated nuts and bolts, and open hole at exhaust pipes. NOTE: Check the following positions. ● Between cylinder head and front exhaust pipe ● Between front exhaust pipe and front catalytic converter ● Between front catalytic converter and rear catalytic converter	Is there a fault in exhaust system?	Repair or replace exhaust system. <Ref. to EX-2, General Description.>	Go to step 3.
3	CHECK REAR CATALYTIC CONVERTER. Separate rear catalytic converter from rear exhaust pipe.	Is there damage at rear face of rear catalyst?	Replace front catalytic converter <Ref. to EC-3, Front Catalytic Converter.> and rear catalytic converter <Ref. to EC-4, Rear Catalytic Converter.>.	Go to step 4.
4	CHECK FRONT CATALYTIC CONVERTER. Remove front catalytic converter.	Is there damage at rear face or front face of front catalyst?	Replace front catalytic converter. <Ref. to EC-3, Front Catalytic Converter.>	Contact with SOA (distributor) service. NOTE: Inspection by DTM is required, because probable cause is deterioration of multiple parts.

DIAGNOSTIC PROCEDURE WITH DIAGNOSTIC TROUBLE CODE (DTC)

Engine (Diagnostics)

AR: DTC P0442 — EVAPORATIVE EMISSION CONTROL SYSTEM MALFUNCTION — S078521B48

- **DTC DETECTING CONDITION:**

- Two consecutive driving cycles with fault

- **TROUBLE SYMPTOM:**

- Gasoline smell
- There is a hole of more than 1.0 mm (0.04 in) dia. in evaporation system or fuel tank.

CAUTION:

After repair or replacement of faulty parts, conduct Clear Memory Mode <Ref. to EN-55, OPERATION, Clear Memory Mode.> and Inspection Mode <Ref. to EN-48, OPERATION, Inspection Mode.>.

DIAGNOSTIC PROCEDURE WITH DIAGNOSTIC TROUBLE CODE (DTC)

Engine (Diagnostics)

● WIRING DIAGRAM:

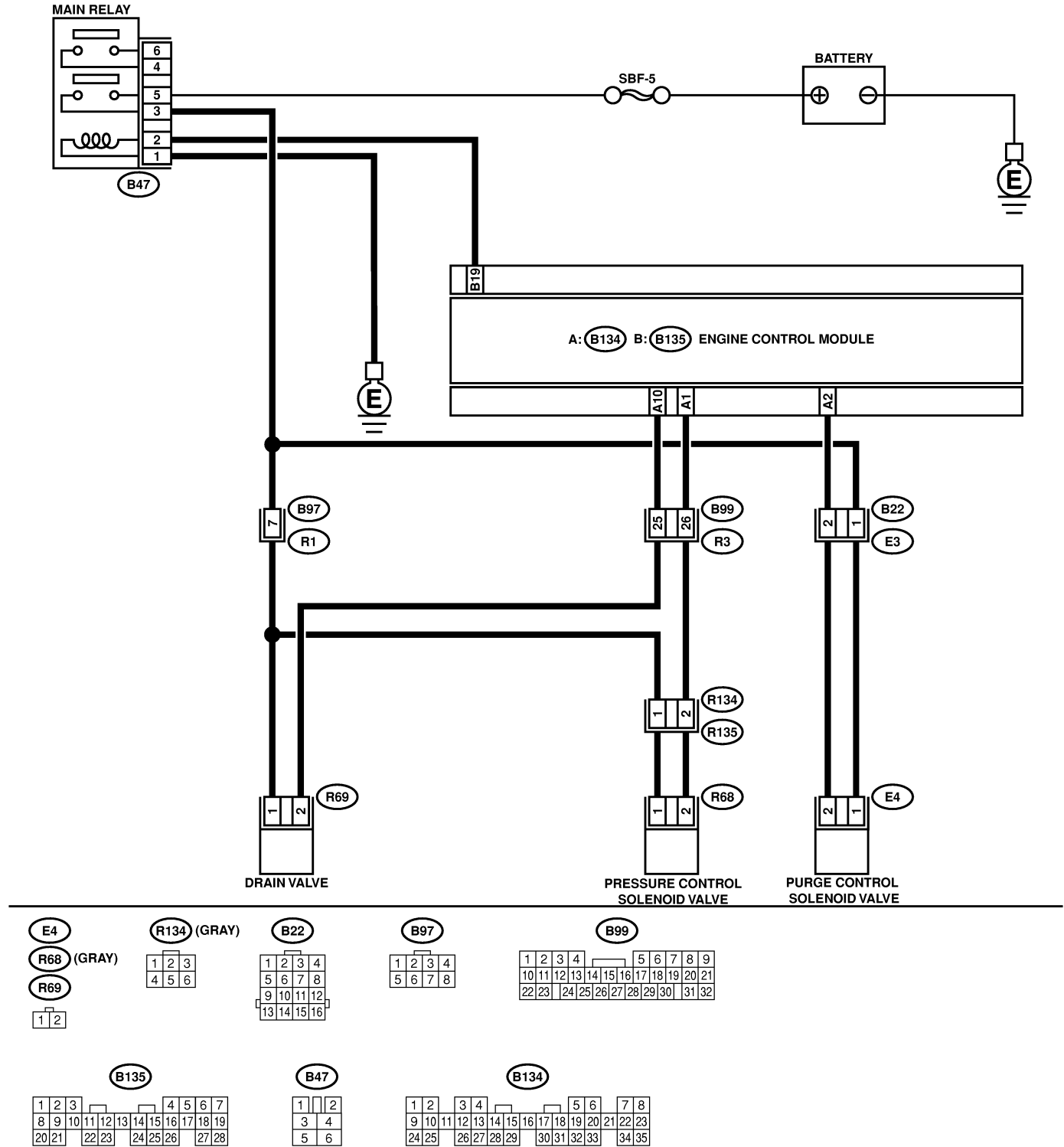

B2M4645

DIAGNOSTIC PROCEDURE WITH DIAGNOSTIC TROUBLE CODE (DTC)

Engine (Diagnostics)

No.	Step	Check	Yes	No
1	CHECK ANY OTHER DTC ON DISPLAY.	Is there any other DTC on display?	Inspect the relevant DTC using "List of Diagnostic Trouble Code (DTC)". <Ref. to EN-88, List of Diagnostic Trouble Code (DTC).>	Go to step 2.
2	CHECK FUEL FILLER CAP. 1) Turn ignition switch to OFF. 2) Check the fuel filler cap. NOTE: The DTC code is stored in memory if fuel filler cap is or was loose or if the cap chain was caught while tightening.	Is the fuel filler cap tightened securely?	Go to step 3.	Tighten fuel filler cap securely.
3	CHECK FUEL FILLER PIPE PACKING.	Is there any damage to the seal between fuel filler cap and fuel filler pipe?	Repair or replace fuel filler cap and fuel filler pipe. <Ref. to FU-65, Fuel Filler Pipe.>	Go to step 4.
4	CHECK DRAIN VALVE. 1) Connect test mode connector. 2) Turn ignition switch to ON. 3) Operate drain valve. NOTE: Drain valve operation can also be executed using Subaru Select Monitor. For the procedure, refer to "Compulsory Valve Operation Check Mode". <Ref. to EN-56, Compulsory Valve Operation Check Mode.>	Does drain valve produce operating sound?	Go to step 5.	Replace drain valve. <Ref. to EC-16, Drain Valve.>
5	CHECK PURGE CONTROL SOLENOID VALVE. Operate purge control solenoid valve. NOTE: Purge control solenoid valve operation can also be executed using Subaru Select Monitor. For the procedure, refer to "Compulsory Valve Operation Check Mode". <Ref. to EN-56, Compulsory Valve Operation Check Mode.>	Does purge control solenoid valve produce operating sound?	Go to step 6.	Replace purge control solenoid valve. <Ref. to EC-6, Purge Control Solenoid Valve.>
6	CHECK PRESSURE CONTROL SOLENOID VALVE. Operate pressure control solenoid valve. NOTE: Pressure control solenoid valve operation can also be executed using Subaru Select Monitor. For the procedure, refer to "Compulsory Valve Operation Check Mode". <Ref. to EN-56, Compulsory Valve Operation Check Mode.>	Does pressure control solenoid valve produce operating sound?	Go to step 7.	Replace pressure control solenoid valve. <Ref. to EC-12, Pressure Control Solenoid Valve.>
7	CHECK EVAPORATIVE EMISSION CONTROL SYSTEM LINE. Turn ignition switch to OFF.	Is there a hole of more than 1.0 mm (0.04 in) dia. on fuel line?	Repair or replace fuel line. <Ref. to FU-81, Fuel Delivery, Return and Evaporation Lines.>	Go to step 8.
8	CHECK CANISTER.	Is canister damaged or is there a hole of more than 1.0 mm (0.04 in) dia. in it?	Repair or replace canister. <Ref. to EC-5, Canister.>	Go to step 9.

DIAGNOSTIC PROCEDURE WITH DIAGNOSTIC TROUBLE CODE (DTC)

Engine (Diagnostics)

No.	Step	Check	Yes	No
9	CHECK FUEL TANK. Remove fuel tank. <Ref. to FU-57, Fuel Tank.>	Is fuel tank damaged or is there a hole of more than 1.0 mm (0.04 in) dia. in it?	Repair or replace fuel tank. <Ref. to FU-57, Fuel Tank.>	Go to step 10.
10	CHECK ANY OTHER MECHANICAL TROUBLE IN EVAPORATIVE EMISSION CONTROL SYSTEM.	Are there holes of more than 1.0 mm (0.04 in) dia., cracks, clogging or disconnections of hoses or pipes in evaporative emission control system?	Repair or replace hoses or pipes.	Contact with SOA (distributor) service. NOTE: Inspection by DTM is required, because probable cause is deterioration of multiple parts.

DIAGNOSTIC PROCEDURE WITH DIAGNOSTIC TROUBLE CODE (DTC)

Engine (Diagnostics)

AS: DTC P0447 — EVAPORATIVE EMISSION CONTROL SYSTEM VENT CONTROL LOW INPUT — S078521F98

● DTC DETECTING CONDITION:

- Two consecutive driving cycles with fault

CAUTION:

After repair or replacement of faulty parts, conduct Clear Memory Mode <Ref. to EN-55, OPERATION, Clear Memory Mode.> and Inspection Mode <Ref. to EN-48, OPERATION, Inspection Mode.>.

● WIRING DIAGRAM:

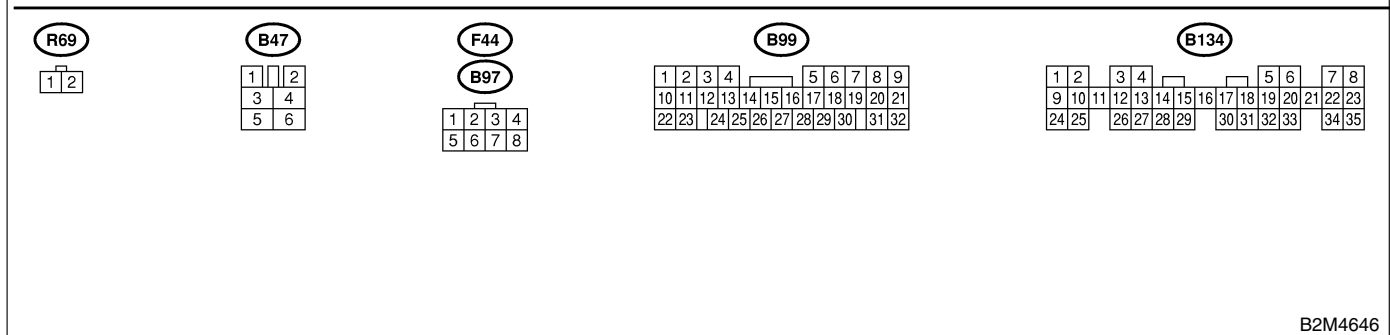
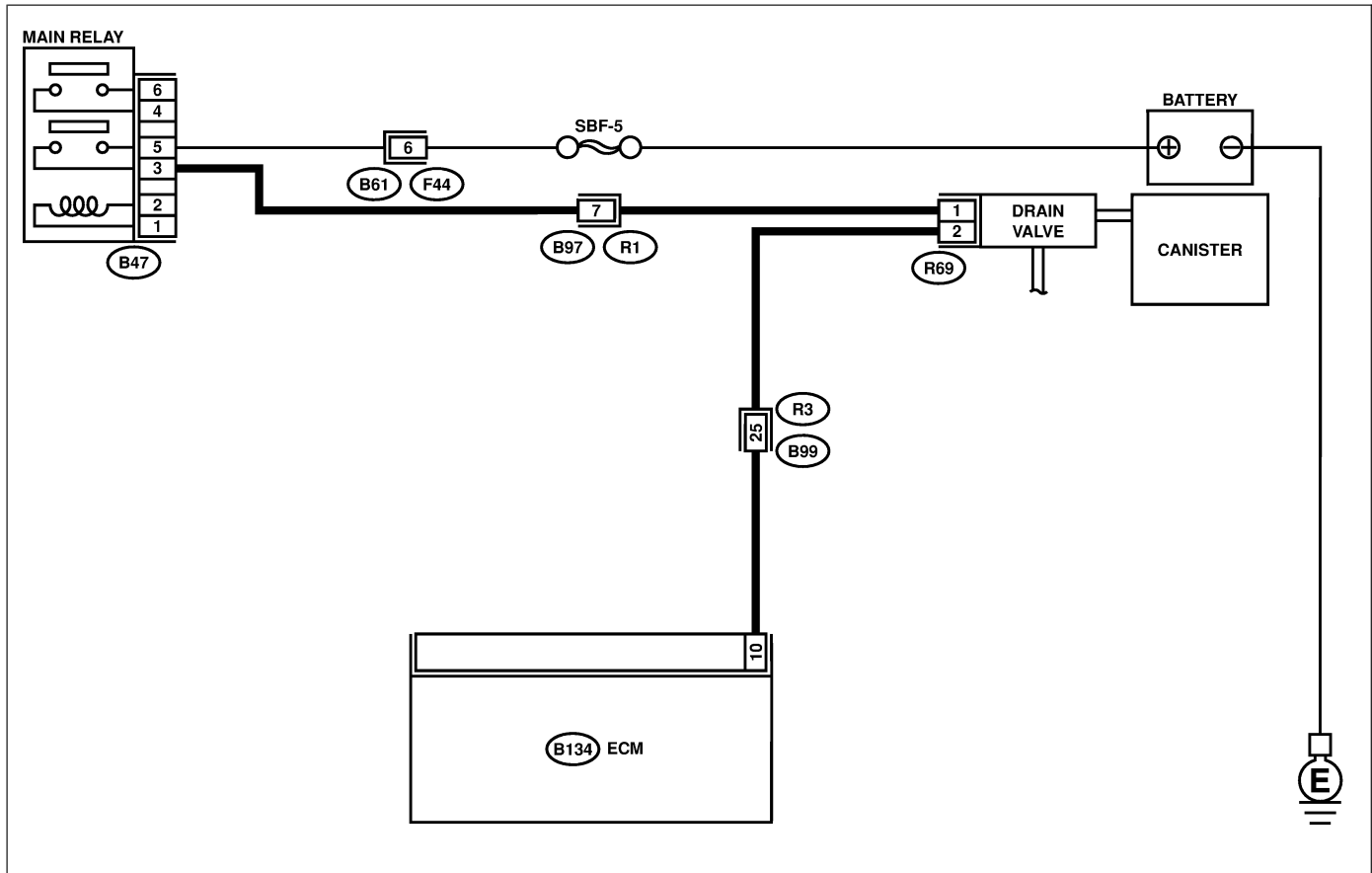

B2M4646

No.	Step	Check	Yes	No
1	CHECK OUTPUT SIGNAL FROM ECM. 1) Turn ignition switch to ON. 2) Measure voltage between ECM and chassis ground. Connector & terminal (B134) No. 10 (+) — Chassis ground (-):	Is the voltage more than 10 V?	Go to step 2.	Go to step 3.

DIAGNOSTIC PROCEDURE WITH DIAGNOSTIC TROUBLE CODE (DTC)

Engine (Diagnostics)

No.	Step	Check	Yes	No
2	<p>CHECK POOR CONTACT. Check poor contact in ECM connector.</p>	Is there poor contact in ECM connector?	Repair poor contact in ECM connector.	<p>Even if MIL lights up, the circuit has returned to a normal condition at this time. (However, the possibility of poor contact still remains.) NOTE: In this case, repair the following:</p> <ul style="list-style-type: none"> ● Poor contact in drain valve connector ● Poor contact in ECM connector ● Poor contact in coupling connectors
3	<p>CHECK HARNESS BETWEEN DRAIN VALVE AND ECM CONNECTOR. 1) Turn ignition switch to OFF. 2) Disconnect connectors from drain valve and ECM. 3) Measure resistance of harness between drain valve connector and chassis ground. Connector & terminal (R69) No. 2 — Chassis ground:</p>	Is the resistance less than 10 Ω?	Repair ground short circuit in harness between ECM and drain valve connector.	Go to step 4.
4	<p>CHECK HARNESS BETWEEN DRAIN VALVE AND ECM CONNECTOR. Measure resistance of harness between ECM and drain valve connector. Connector & terminal (B134) No. 10 — (R69) No. 2:</p>	Is the voltage less than 1 Ω?	Go to step 5.	<p>Repair harness and connector. NOTE: In this case, repair the following:</p> <ul style="list-style-type: none"> ● Open circuit in harness between ECM and drain valve connector ● Poor contact in coupling connectors
5	<p>CHECK DRAIN VALVE. Measure resistance between drain valve terminals. Terminals No. 1 — No. 2:</p>	Is the resistance between 10 and 100 Ω?	Go to step 6.	Replace drain valve. <Ref. to EC-16, Drain Valve.>

DIAGNOSTIC PROCEDURE WITH DIAGNOSTIC TROUBLE CODE (DTC)

Engine (Diagnostics)

No.	Step	Check	Yes	No
6	<p>CHECK POWER SUPPLY TO DRAIN VALVE. 1) Turn ignition switch to ON. 2) Measure voltage between drain valve and chassis ground. Connector & terminal (R69) No. 1 (+) — Chassis ground (-):</p>	Is the voltage more than 10 V?	Go to step 7.	Repair harness and connector. NOTE: In this case, repair the following: <ul style="list-style-type: none"> ● Open circuit in harness between main relay and drain valve ● Poor contact in coupling connectors ● Poor contact in main relay connector
7	<p>CHECK POOR CONTACT. Check poor contact in drain valve connector.</p>	Is there poor contact in drain valve connector?	Repair poor contact in drain valve connector.	Contact with SOA (distributor) service. NOTE: Inspection by DTM is required, because probable cause is deterioration of multiple parts.

MEMO:

DIAGNOSTIC PROCEDURE WITH DIAGNOSTIC TROUBLE CODE (DTC)

Engine (Diagnostics)

AT: DTC P0448 — EVAPORATIVE EMISSION CONTROL SYSTEM VENT CONTROL HIGH INPUT — S078521F99

● DTC DETECTING CONDITION:

- Two consecutive driving cycles with fault

CAUTION:

After repair or replacement of faulty parts, conduct Clear Memory Mode <Ref. to EN-55, OPERATION, Clear Memory Mode.> and Inspection Mode <Ref. to EN-48, OPERATION, Inspection Mode.>.

● WIRING DIAGRAM:

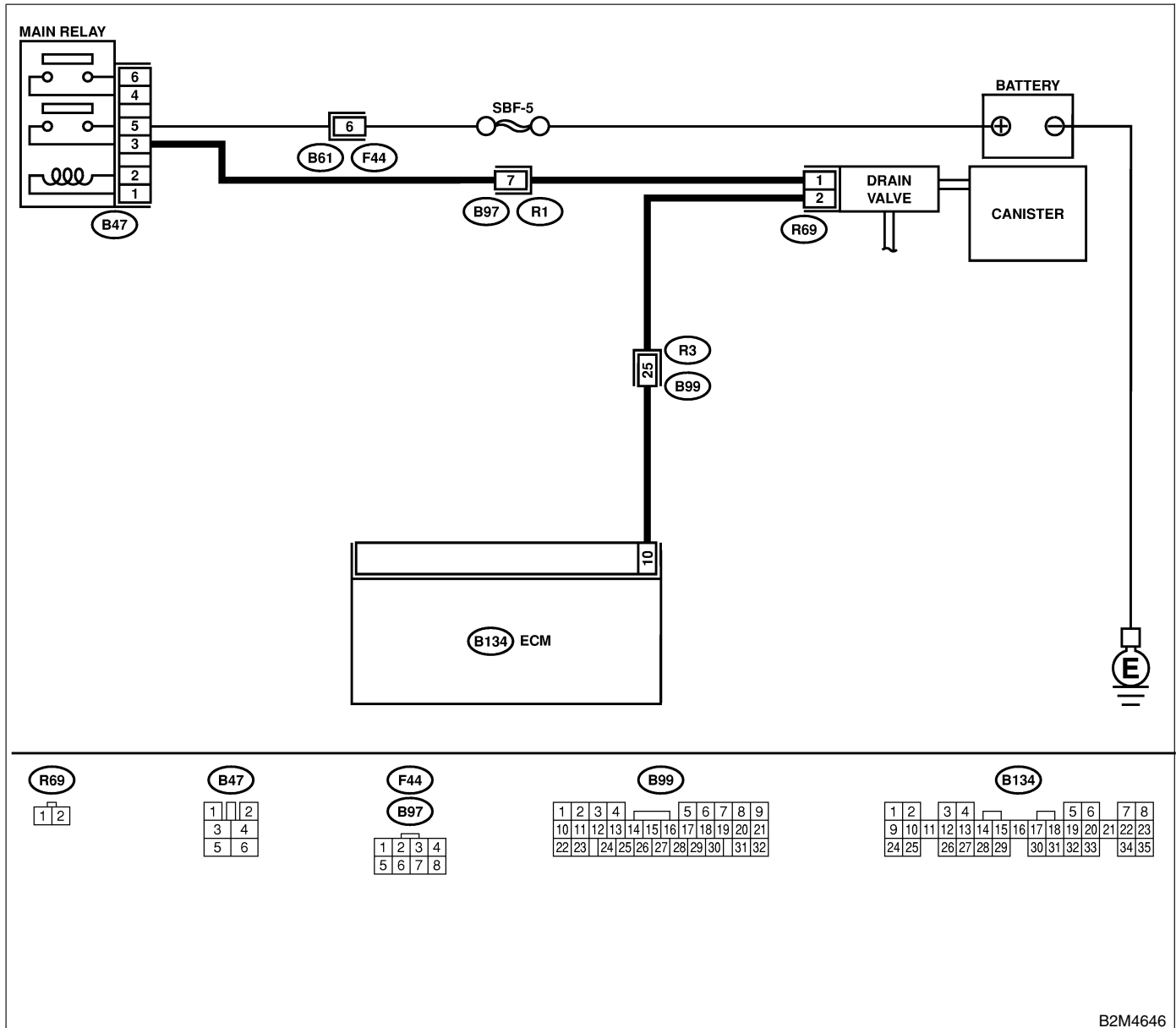

B2M4646

DIAGNOSTIC PROCEDURE WITH DIAGNOSTIC TROUBLE CODE (DTC)

Engine (Diagnostics)

No.	Step	Check	Yes	No
1	<p>CHECK OUTPUT SIGNAL FROM ECM. 1) Turn ignition switch to OFF. 2) Connect test mode connector at the lower portion of instrument panel (on the driver's side), to the side of the center console box. 3) Turn ignition switch to ON. 4) While operating drain valve, measure voltage between ECM and chassis ground. NOTE: Drain valve operation can be executed using Subaru Select Monitor. For procedure, refer to "Compulsory Valve Operation Check Mode". <Ref. to EN-56, Compulsory Valve Operation Check Mode.></p> <p>Connector & terminal (B134) No. 10 (+) — Chassis ground (-):</p>	Does voltage change between 0 and 10 V?	Go to step 2.	Even if MIL light up, the circuit has returned to a normal condition at this time. In this case, repair poor contact in ECM connector.
2	<p>CHECK OUTPUT SIGNAL FROM ECM. 1) Turn ignition switch to ON. 2) Measure voltage between ECM and chassis ground. Connector & terminal (B134) No. 10 (+) — Chassis ground (-):</p>	Is the voltage more than 10 V?	Go to step 4.	Go to step 3.
3	<p>CHECK POOR CONTACT. Check poor contact in ECM connector.</p>	Is there poor contact in ECM connector?	Repair poor contact in ECM connector.	Replace ECM. <Ref. to FU-51, Engine Control Module.>
4	<p>CHECK HARNESS BETWEEN DRAIN VALVE AND ECM CONNECTOR. 1) Turn ignition switch to OFF. 2) Disconnect connector from drain valve. 3) Turn ignition switch to ON. 4) Measure voltage between ECM and chassis ground. Connector & terminal (B134) No. 10 (+) — Chassis ground (-):</p>	Is the voltage more than 10 V?	Repair battery short circuit in harness between ECM and drain valve connector. After repair, replace ECM. <Ref. to FU-51, Engine Control Module.>	Go to step 5.
5	<p>CHECK DRAIN VALVE. 1) Turn ignition switch to OFF. 2) Measure resistance between drain valve terminals. Terminals No. 1 — No. 2:</p>	Is the resistance less than 1 Ω ?	Replace drain valve <Ref. to EC-16, Drain Valve.> and ECM <Ref. to FU-51, Engine Control Module.>	Go to step 6.
6	<p>CHECK POOR CONTACT. Check poor contact in ECM connector.</p>	Is there poor contact in ECM connector?	Repair poor contact in ECM connector.	Replace ECM. <Ref. to FU-51, Engine Control Module.>

DIAGNOSTIC PROCEDURE WITH DIAGNOSTIC TROUBLE CODE (DTC)

Engine (Diagnostics)

AU: DTC P0451 — EVAPORATIVE EMISSION CONTROL SYSTEM PRESSURE SENSOR RANGE/PERFORMANCE PROBLEM — S078521B51

● DTC DETECTING CONDITION:

- Two consecutive driving cycles with fault

CAUTION:

After repair or replacement of faulty parts, conduct Clear Memory Mode <Ref. to EN-55, OPERATION, Clear Memory Mode.> and Inspection Mode <Ref. to EN-48, OPERATION, Inspection Mode.>.

● WIRING DIAGRAM:

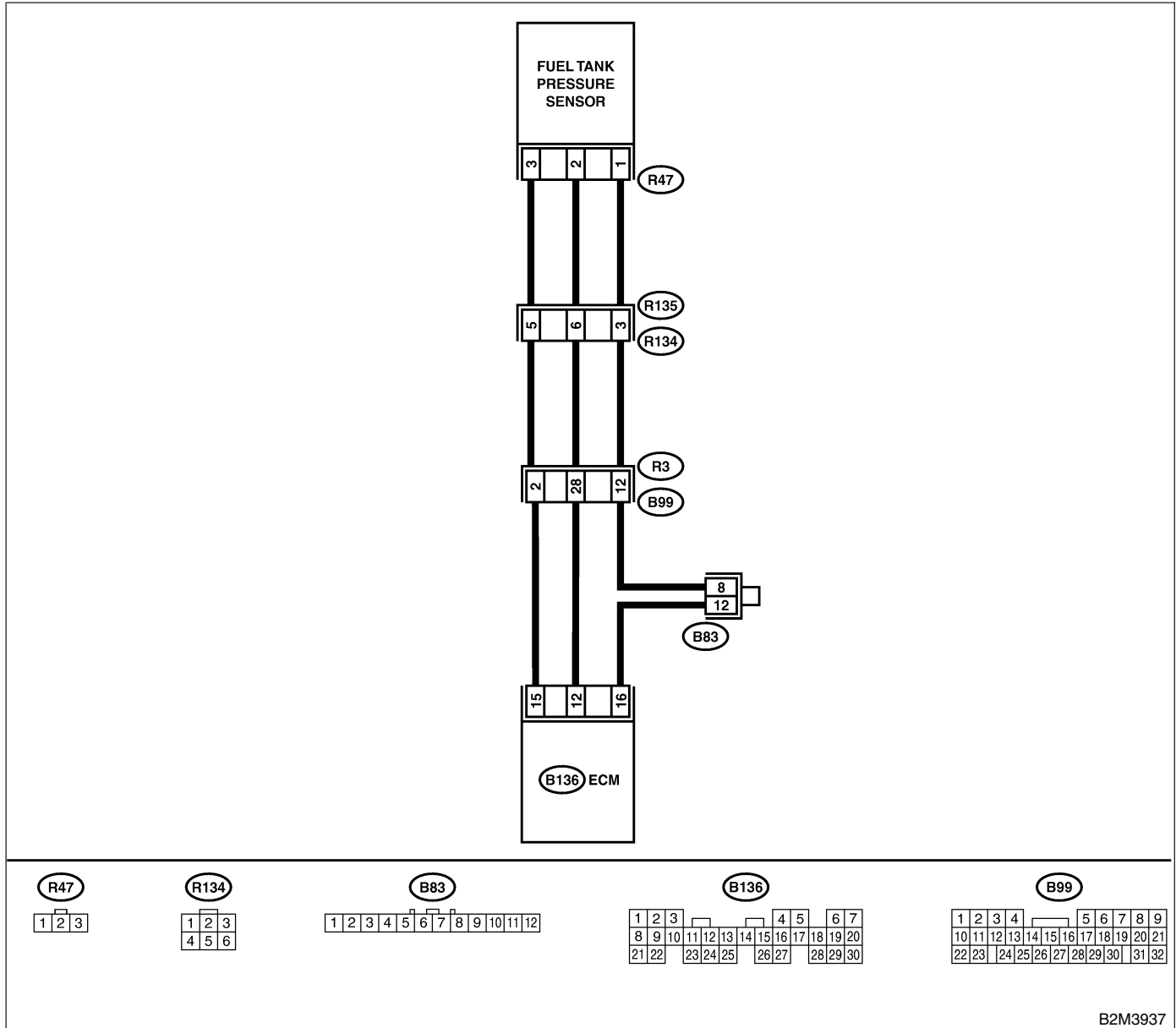

B2M3937

DIAGNOSTIC PROCEDURE WITH DIAGNOSTIC TROUBLE CODE (DTC)

Engine (Diagnostics)

No.	Step	Check	Yes	No
1	CHECK ANY OTHER DTC ON DISPLAY.	Is there any DTC on display?	Inspect the relevant DTC using "List of Diagnostic Trouble Code (DTC)". <Ref. to EN-88, List of Diagnostic Trouble Code (DTC).>	Go to step 2.
2	CHECK FUEL FILLER CAP. 1) Turn ignition switch to OFF. 2) Open the fuel flap.	Is the fuel filler cap tightened securely?	Go to step 3.	Tighten fuel filler cap securely.
3	CHECK PRESSURE/VACUUM LINE. NOTE: Check the following items. <ul style="list-style-type: none">● Disconnection, leakage and clogging of the vacuum hoses and pipes between fuel tank pressure sensor and fuel tank● Disconnection, leakage and clogging of air ventilation hoses and pipes between fuel filler pipe and fuel tank	Is there a fault in pressure/vacuum line?	Repair or replace hoses and pipes.	Replace fuel tank pressure sensor. <Ref. to EC-10, Fuel Tank Pressure Sensor.>

DIAGNOSTIC PROCEDURE WITH DIAGNOSTIC TROUBLE CODE (DTC)

Engine (Diagnostics)

AV: DTC P0452 — EVAPORATIVE EMISSION CONTROL SYSTEM PRESSURE SENSOR LOW INPUT — S078521B52

● DTC DETECTING CONDITION:

- Two consecutive driving cycles with fault

CAUTION:

After repair or replacement of faulty parts, conduct Clear Memory Mode <Ref. to EN-55, OPERATION, Clear Memory Mode.> and Inspection Mode <Ref. to EN-48, OPERATION, Inspection Mode.>.

● WIRING DIAGRAM:

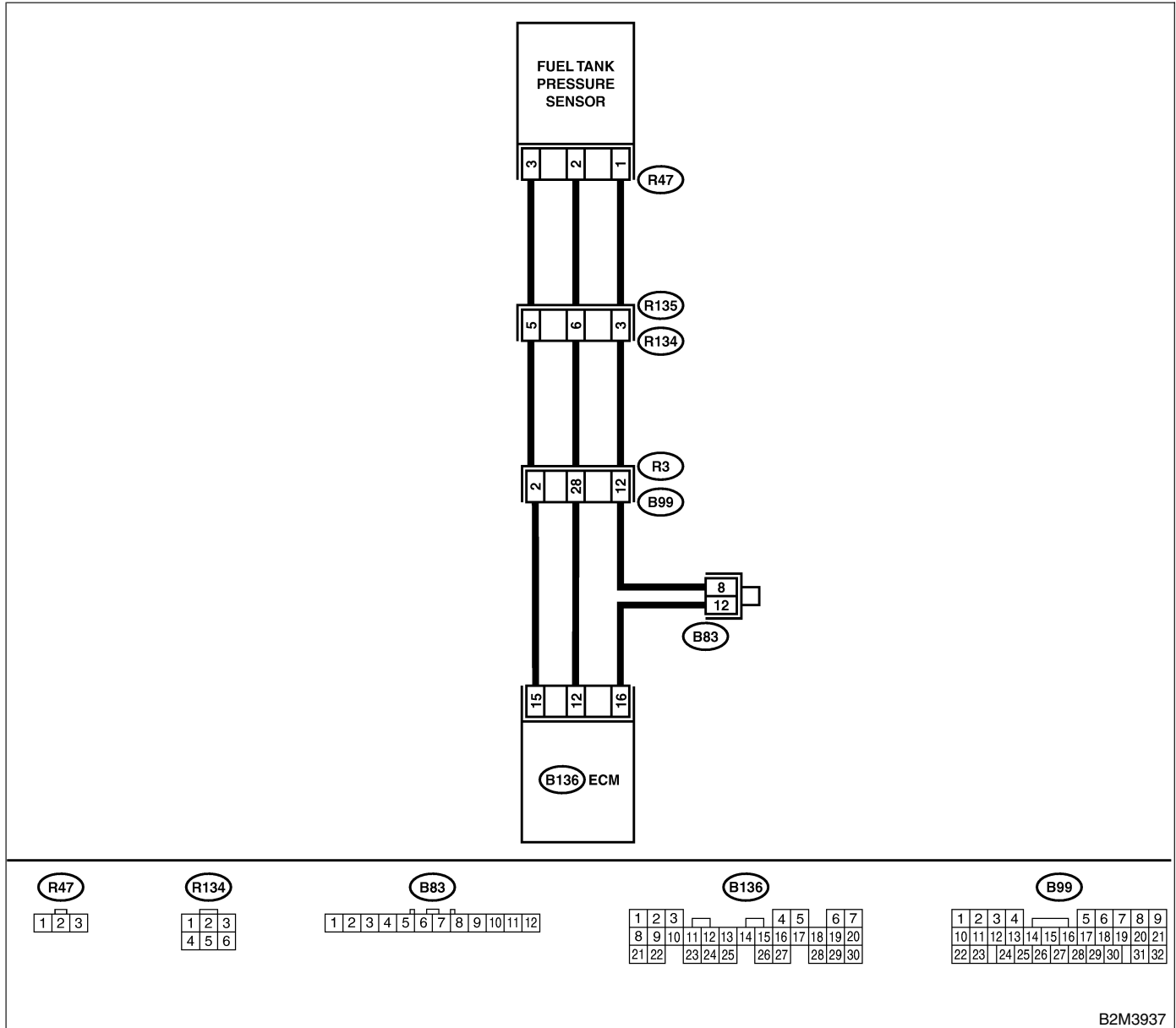

B2M3937

DIAGNOSTIC PROCEDURE WITH DIAGNOSTIC TROUBLE CODE (DTC)

Engine (Diagnostics)

No.	Step	Check	Yes	No
1	<p>CHECK CURRENT DATA. 1) Turn ignition switch to OFF. 2) Remove fuel filler cap. 3) Install fuel filler cap. 4) Turn ignition switch to ON. 5) Read the data of fuel tank pressure sensor signal using Subaru Select Monitor or the OBD-II general scan tool. NOTE: ● Subaru Select Monitor For detailed operation procedure, refer to the "READ CURRENT DATA FOR ENGINE". <Ref. to EN-36, Subaru Select Monitor.> ● OBD-II general scan tool For detailed operation procedures, refer to the OBD-II General Scan Tool Instruction Manual.</p>	Is the value less than -2.8 kPa (-21.0 mmHg, -0.827 inHg)?	Go to step 2.	Even if MIL lights up, the circuit has returned to a normal condition at this time.
2	<p>CHECK POWER SUPPLY TO FUEL TANK PRESSURE SENSOR. Measure voltage between ECM connector and chassis ground. <i>Connector & terminal</i> <i>(B136) No. 15 (+) — Chassis ground (-):</i></p>	Is the voltage more than 4.5 V?	Go to step 4.	Go to step 3.
3	<p>CHECK POWER SUPPLY TO FUEL TANK PRESSURE SENSOR. Measure voltage between ECM connector and chassis ground. <i>Connector & terminal</i> <i>(B136) No. 15 (+) — Chassis ground (-):</i></p>	Does the voltage change more than 4.5 V by shaking harness and connector of ECM while monitoring the value with voltage meter?	Repair poor contact in ECM connector.	Contact with SOA (distributor) service. NOTE: Inspection by DTM is required, because probable cause is deterioration of multiple parts.
4	<p>CHECK INPUT SIGNAL FOR ECM. Measure voltage between ECM and chassis ground. <i>Connector & terminal</i> <i>(B136) No. 12 (+) — Chassis ground (-):</i></p>	Is the voltage less than 0.2 V?	Go to step 6.	Go to step 5.
5	<p>CHECK INPUT SIGNAL FOR ECM. (USING SUBARU SELECT MONITOR.) Read data of fuel tank pressure sensor signal using Subaru Select Monitor. NOTE: ● Subaru Select Monitor For detailed operation procedure, refer to the "READ CURRENT DATA FOR ENGINE". <Ref. to EN-36, Subaru Select Monitor.></p>	Does the value change more than -2.8 kPa (-21.0 mmHg, -0.827 inHg) by shaking harness and connector of ECM while monitoring the value with Subaru Select Monitor?	Repair poor contact in ECM connector.	Go to step 6.

DIAGNOSTIC PROCEDURE WITH DIAGNOSTIC TROUBLE CODE (DTC)

Engine (Diagnostics)

No.	Step	Check	Yes	No
6	<p>CHECK HARNESS BETWEEN ECM AND COUPLING CONNECTOR IN REAR WIRING HARNESS.</p> <p>1) Turn ignition switch to OFF. 2) Remove rear seat cushion (Sedan) or move rear seat cushion (Wagon). 3) Separate rear wiring harness and fuel tank cord. 4) Turn ignition switch to ON. 5) Measure voltage between rear wiring harness connector and chassis ground.</p> <p>Connector & terminal (R134) No. 5 (+) — Chassis ground (-):</p>	Is the voltage more than 4.5 V?	Go to step 7.	Repair harness and connector. NOTE: In this case, repair the following: ● Open circuit in harness between ECM and rear wiring harness connector ● Poor contact in coupling connector
7	<p>CHECK HARNESS BETWEEN ECM AND COUPLING CONNECTOR IN REAR WIRING HARNESS.</p> <p>1) Turn ignition switch to OFF. 2) Disconnect connector from ECM. 3) Measure resistance of harness between ECM and rear wiring harness connector.</p> <p>Connector & terminal (B136) No. 16 — (R134) No. 3:</p>	Is the resistance less than 1 Ω?	Go to step 8.	Repair harness and connector. NOTE: In this case, repair the following: ● Open circuit in harness between ECM and rear wiring harness connector ● Poor contact in coupling connector ● Poor contact in joint connector
8	<p>CHECK HARNESS BETWEEN ECM AND COUPLING CONNECTOR IN REAR WIRING HARNESS.</p> <p>Measure resistance of harness between rear wiring harness connector and chassis ground.</p> <p>Connector & terminal (R134) No. 3 — Chassis ground:</p>	Is the resistance more than 500 kΩ?	Go to step 9.	Repair ground short circuit in harness between ECM and rear wiring harness connector.
9	<p>CHECK FUEL TANK CORD.</p> <p>1) Disconnect connector from fuel tank pressure sensor. 2) Measure resistance of fuel tank cord.</p> <p>Connector & terminal (R135) No. 5 — (R47) No. 3:</p>	Is the resistance less than 1 Ω?	Go to step 10.	Repair open circuit in fuel tank cord.
10	<p>CHECK FUEL TANK CORD.</p> <p>Measure resistance of fuel tank cord.</p> <p>Connector & terminal (R135) No. 3 — (R47) No. 1:</p>	Is the resistance less than 1 Ω?	Go to step 11.	Repair open circuit in fuel tank cord.
11	<p>CHECK FUEL TANK CORD.</p> <p>Measure resistance of harness between fuel tank pressure sensor connector and chassis ground.</p> <p>Connector & terminal (R47) No. 2 — Chassis ground:</p>	Is the resistance more than 500 kΩ?	Go to step 12.	Repair ground short circuit in fuel tank cord.
12	<p>CHECK POOR CONTACT.</p> <p>Check poor contact in fuel tank pressure sensor connector.</p>	Is there poor contact in fuel tank pressure sensor connector?	Repair poor contact in fuel tank pressure sensor connector.	Replace fuel tank pressure sensor. <Ref. to EC-10, Fuel Tank Pressure Sensor.>

MEMO:

DIAGNOSTIC PROCEDURE WITH DIAGNOSTIC TROUBLE CODE (DTC)

Engine (Diagnostics)

AW: DTC P0453 — EVAPORATIVE EMISSION CONTROL SYSTEM PRESSURE SENSOR HIGH INPUT — S078521B53

● DTC DETECTING CONDITION:

- Two consecutive driving cycles with fault

CAUTION:

After repair or replacement of faulty parts, conduct Clear Memory Mode <Ref. to EN-55, OPERATION, Clear Memory Mode.> and Inspection Mode <Ref. to EN-48, OPERATION, Inspection Mode.>.

● WIRING DIAGRAM:

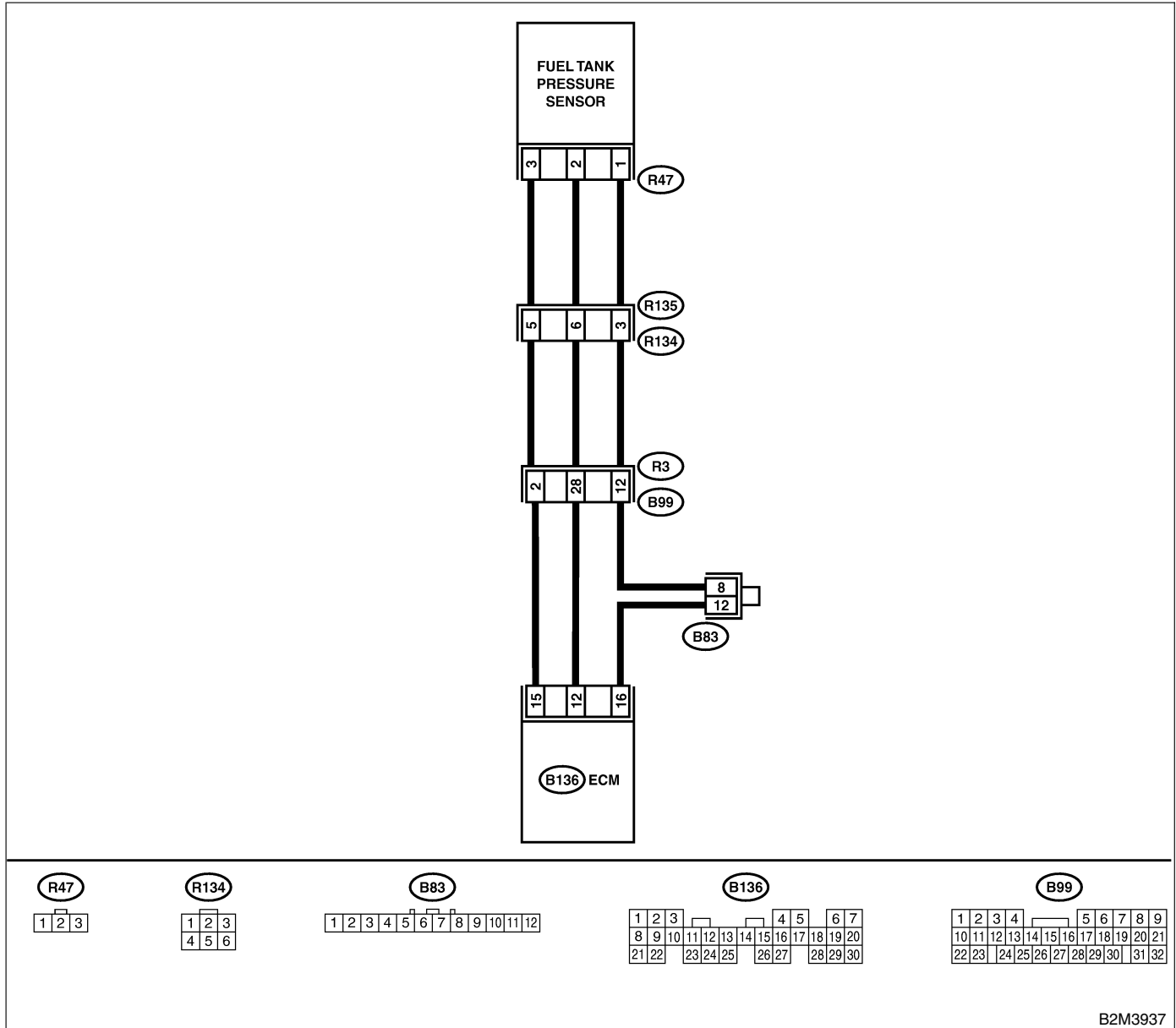

B2M3937

DIAGNOSTIC PROCEDURE WITH DIAGNOSTIC TROUBLE CODE (DTC)

Engine (Diagnostics)

No.	Step	Check	Yes	No
1	<p>CHECK CURRENT DATA.</p> <p>1) Turn ignition switch to OFF. 2) Remove fuel filler cap. 3) Install fuel filler cap. 4) Turn ignition switch to ON. 5) Read data of fuel tank pressure sensor signal using Subaru Select Monitor or OBD-II general scan tool.</p> <p>NOTE:</p> <ul style="list-style-type: none"> ● Subaru Select Monitor <p>For detailed operation procedure, refer to the "READ CURRENT DATA FOR ENGINE". <Ref. to EN-36, Subaru Select Monitor.></p> <ul style="list-style-type: none"> ● OBD-II general scan tool <p>For detailed operation procedures, refer to the OBD-II General Scan Tool Instruction Manual.</p>	Is the value more than 2.8 kPa (21.0 mmHg, 0.827 inHg)?	Go to step 12.	Go to step 2.
2	<p>CHECK POWER SUPPLY TO FUEL TANK PRESSURE SENSOR.</p> <p>Measure voltage between ECM connector and chassis ground.</p> <p>Connector & terminal (B136) No. 15 (+) — Chassis ground (-):</p>	Is the voltage more than 4.5 V?	Go to step 4.	Go to step 3.
3	<p>CHECK POWER SUPPLY TO FUEL TANK PRESSURE SENSOR.</p> <p>Measure voltage between ECM connector and chassis ground.</p> <p>Connector & terminal (B136) No. 15 (+) — Chassis ground (-):</p>	Does the voltage change more than 4.5 V by shaking harness and connector of ECM while monitoring the value with voltage meter?	Repair poor contact in ECM connector.	Replace ECM. <Ref. to FU-51, Engine Control Module.>
4	<p>CHECK INPUT SIGNAL FOR ECM.</p> <p>Measure voltage between ECM and chassis ground.</p> <p>Connector & terminal (B136) No. 12 (+) — Chassis ground (-):</p>	Is the voltage less than 0.2 V?	Go to step 6.	Go to step 5.
5	<p>CHECK INPUT SIGNAL FOR ECM. (USING SUBARU SELECT MONITOR.)</p> <p>Read data of fuel tank pressure sensor signal using Subaru Select Monitor.</p> <p>NOTE:</p> <ul style="list-style-type: none"> ● Subaru Select Monitor <p>For detailed operation procedure, refer to the "READ CURRENT DATA FOR ENGINE". <Ref. to EN-36, Subaru Select Monitor.></p>	Does the value change more than -2.8 kPa (-21.0 mmHg, -0.827 inHg) by shaking harness and connector of ECM while monitoring the value with Subaru Select Monitor?	Repair poor contact in ECM connector.	Go to step 6.
6	<p>CHECK HARNESS BETWEEN ECM AND COUPLING CONNECTOR IN REAR WIRING HARNESS.</p> <p>1) Turn ignition switch to OFF. 2) Remove rear seat cushion (Sedan) or move rear seat cushion (Wagon). 3) Separate rear wiring harness and fuel tank cord. 4) Turn ignition switch to ON. 5) Measure voltage between rear wiring harness connector and chassis ground.</p> <p>Connector & terminal (R134) No. 5 (+) — Chassis ground (-):</p>	Is the voltage more than 4.5 V?	Go to step 7.	Repair harness and connector. NOTE: In this case, repair the following: ● Open circuit in harness between ECM and rear wiring harness connector ● Poor contact in coupling connector

DIAGNOSTIC PROCEDURE WITH DIAGNOSTIC TROUBLE CODE (DTC)

Engine (Diagnostics)

No.	Step	Check	Yes	No
7	<p>CHECK HARNESS BETWEEN ECM AND COUPLING CONNECTOR IN REAR WIRING HARNESS.</p> <p>1) Turn ignition switch to OFF. 2) Disconnect connector from ECM. 3) Measure resistance of harness between ECM and rear wiring harness connector.</p> <p>Connector & terminal (B136) No. 12 — (R134) No. 6:</p>	Is the resistance less than 1 Ω?	Go to step 8.	<p>Repair harness and connector.</p> <p>NOTE: In this case, repair the following:</p> <ul style="list-style-type: none"> ● Open circuit in harness between ECM and rear wiring harness connector ● Poor contact in coupling connector
8	<p>CHECK HARNESS BETWEEN ECM AND COUPLING CONNECTOR IN REAR WIRING HARNESS.</p> <p>Measure resistance of harness between rear wiring harness connector and chassis ground.</p> <p>Connector & terminal (B136) No. 16 — (R134) No. 3:</p>	Is the resistance less than 1 Ω?	Go to step 9.	Repair ground short circuit in harness between ECM and rear wiring harness connector.
9	<p>CHECK FUEL TANK CORD.</p> <p>1) Disconnect connector from fuel tank pressure sensor. 2) Measure resistance of fuel tank cord.</p> <p>Connector & terminal (R135) No. 6 — (R47) No. 2:</p>	Is the resistance less than 1 Ω?	Go to step 10.	Repair open circuit in fuel tank cord.
10	<p>CHECK FUEL TANK CORD.</p> <p>Measure resistance of fuel tank cord.</p> <p>Connector & terminal (R135) No. 3 — (R47) No. 1:</p>	Is the resistance less than 1 Ω?	Go to step 11.	Repair open circuit in fuel tank cord.
11	<p>CHECK POOR CONTACT.</p> <p>Check poor contact in fuel tank pressure sensor connector.</p>	Is there poor contact in fuel tank pressure sensor connector?	Repair poor contact in fuel tank pressure sensor connector.	Replace fuel tank pressure sensor. <Ref. to FU-10, Fuel Tank Pressure Sensor.>
12	<p>CHECK HARNESS BETWEEN ECM AND FUEL TANK PRESSURE SENSOR CONNECTOR.</p> <p>1) Turn ignition switch to OFF. 2) Disconnect connector from fuel tank pressure sensor. 3) Turn ignition switch to ON. 4) Read data of fuel tank pressure sensor signal using Subaru Select Monitor or the OBD-II general scan tool.</p> <p>NOTE:</p> <ul style="list-style-type: none"> ● Subaru Select Monitor For detailed operation procedure, refer to the "READ CURRENT DATA FOR ENGINE". <Ref. to EN-36, Subaru Select Monitor.> ● OBD-II general scan tool For detailed operation procedures, refer to the OBD-II General Scan Tool Instruction Manual. 	Is the value more than 2.8 kPa (21.0 mmHg, 0.827 inHg)?	Repair battery short circuit in harness between ECM and fuel tank pressure sensor connector.	Replace fuel tank pressure sensor. <Ref. to FU-10, Fuel Tank Pressure Sensor.>

MEMO:

DIAGNOSTIC PROCEDURE WITH DIAGNOSTIC TROUBLE CODE (DTC)

Engine (Diagnostics)

AX: DTC P0456 — EVAPORATIVE EMISSION CONTROL SYSTEM MALFUNCTION — S078521G00

● **DTC DETECTING CONDITION:**

- Two consecutive driving cycles with fault

● **TROUBLE SYMPTOM:**

- Gasoline smell
- There is a hole of more than 0.5 mm (0.020 in) dia. in evaporation system or fuel tank.

CAUTION:

After repair or replacement of faulty parts, conduct Clear Memory Mode <Ref. to EN-55, OPERATION, Clear Memory Mode.> and Inspection Mode <Ref. to EN-48, OPERATION, Inspection Mode.>.

DIAGNOSTIC PROCEDURE WITH DIAGNOSTIC TROUBLE CODE (DTC)

Engine (Diagnostics)

● WIRING DIAGRAM:

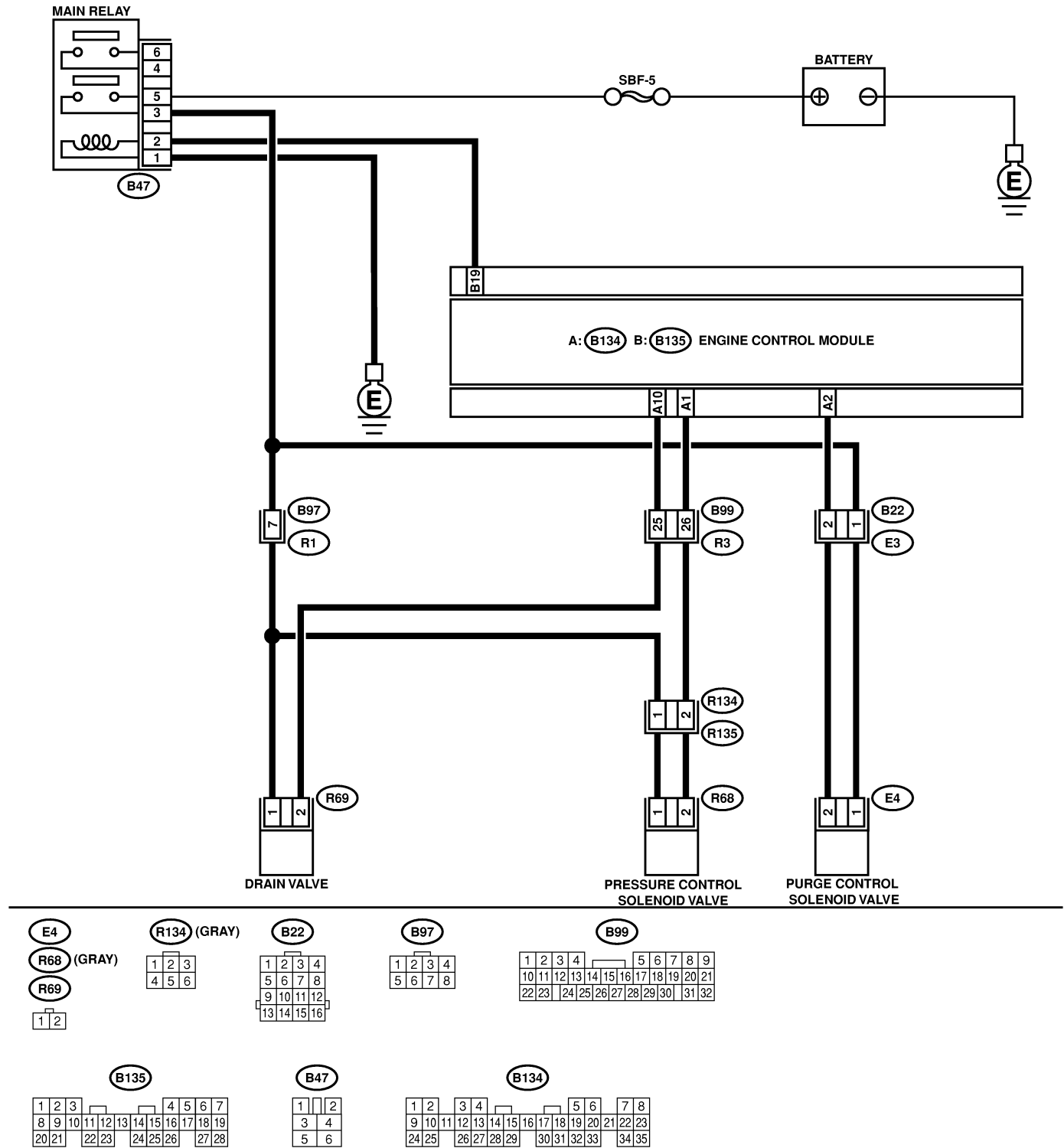

B2M4645

DIAGNOSTIC PROCEDURE WITH DIAGNOSTIC TROUBLE CODE (DTC)

Engine (Diagnostics)

No.	Step	Check	Yes	No
1	CHECK ANY OTHER DTC ON DISPLAY.	Is any other DTC displayed?	Inspect the relevant DTC using "List of Diagnostic Trouble Code (DTC)". <Ref. to EN-88, List of Diagnostic Trouble Code (DTC).>	Go to step 2.
2	CHECK FUEL FILLER CAP. 1) Turn ignition switch to OFF. 2) Check the fuel filler cap. NOTE: The DTC code is stored in memory if fuel filler cap is or was loose or if the cap chain was caught while tightening.	Is the fuel filler cap tightened securely?	Go to step 3.	Tighten fuel filler cap securely.
3	CHECK FUEL FILLER PIPE PACKING.	Is there any damage to the seal between fuel filler cap and fuel filler pipe?	Repair or replace fuel filler cap and fuel filler pipe. <Ref. to FU-65, Fuel Filler Pipe.>	Go to step 4.
4	CHECK DRAIN VALVE. 1) Connect test mode connector. 2) Turn ignition switch to ON. 3) Operate drain valve. NOTE: Drain valve operation can also be executed using Subaru Select Monitor. For the procedure, refer to "Compulsory Valve Operation Check Mode". <Ref. to EN-56, Compulsory Valve Operation Check Mode.>	Does drain valve produce operating sound?	Go to step 5.	Replace drain valve. <Ref. to EC-16, Drain Valve.>
5	CHECK PURGE CONTROL SOLENOID VALVE. Operate purge control solenoid valve. NOTE: Purge control solenoid valve operation can also be executed using Subaru Select Monitor. For the procedure, refer to "Compulsory Valve Operation Check Mode". <Ref. to EN-56, Compulsory Valve Operation Check Mode.>	Does purge control solenoid valve produce operating sound?	Go to step 6.	Replace purge control solenoid valve. <Ref. to EC-6, Purge Control Solenoid Valve.>
6	CHECK PRESSURE CONTROL SOLENOID VALVE. Operate pressure control solenoid valve. NOTE: Pressure control solenoid valve operation can also be executed using Subaru Select Monitor. For the procedure, refer to "Compulsory Valve Operation Check Mode". <Ref. to EN-56, Compulsory Valve Operation Check Mode.>	Does pressure control solenoid valve produce operating sound?	Go to step 7.	Replace pressure control solenoid valve. <Ref. to EC-12, Pressure Control Solenoid Valve.>
7	CHECK EVAPORATIVE EMISSION CONTROL SYSTEM LINE. Turn ignition switch to OFF.	Is there a hole of more than 0.5 mm (0.020 in) dia. on fuel line?	Repair or replace fuel line. <Ref. to FU-81, Fuel Delivery, Return and Evaporation Lines.>	Go to step 8.
8	CHECK CANISTER.	Is canister damaged or is there a hole of more than 0.5 mm (0.020 in) dia. in it?	Repair or replace canister. <Ref. to EC-5, Canister.>	Go to step 9.

DIAGNOSTIC PROCEDURE WITH DIAGNOSTIC TROUBLE CODE (DTC)

Engine (Diagnostics)

No.	Step	Check	Yes	No
9	CHECK FUEL TANK. Remove fuel tank. <Ref. to FU-57, Fuel Tank.>	Is fuel tank damaged or is there a hole of more than 0.5 mm (0.020 in) dia. in it?	Repair or replace fuel tank. <Ref. to FU-57, Fuel Tank.>	Go to step 10.
10	CHECK ANY OTHER MECHANICAL TROUBLE IN EVAPORATIVE EMISSION CONTROL SYSTEM.	Are there holes of more than 0.5 mm (0.020 in) dia., cracks, clogging or disconnections of hoses or pipes in evaporative emission control system?	Repair or replace hoses or pipes.	Contact with SOA (distributor) service. NOTE: Inspection by DTM is required, because probable cause is deterioration of multiple parts.

DIAGNOSTIC PROCEDURE WITH DIAGNOSTIC TROUBLE CODE (DTC)

Engine (Diagnostics)

AY: DTC P0457 — EVAPORATIVE EMISSION CONTROL SYSTEM MALFUNCTION — S078521K05

- **DTC DETECTING CONDITION:**
 - Two consecutive driving cycles with fault
- **TROUBLE SYMPTOM:**
 - Gasoline smell
 - Fuel filler cap loose or missing

CAUTION:

After repair or replacement of faulty parts, conduct Clear Memory Mode <Ref. to EN-55, OPERATION, Clear Memory Mode.> and Inspection Mode <Ref. to EN-48, OPERATION, Inspection Mode.>.

DIAGNOSTIC PROCEDURE WITH DIAGNOSTIC TROUBLE CODE (DTC)

Engine (Diagnostics)

● WIRING DIAGRAM:

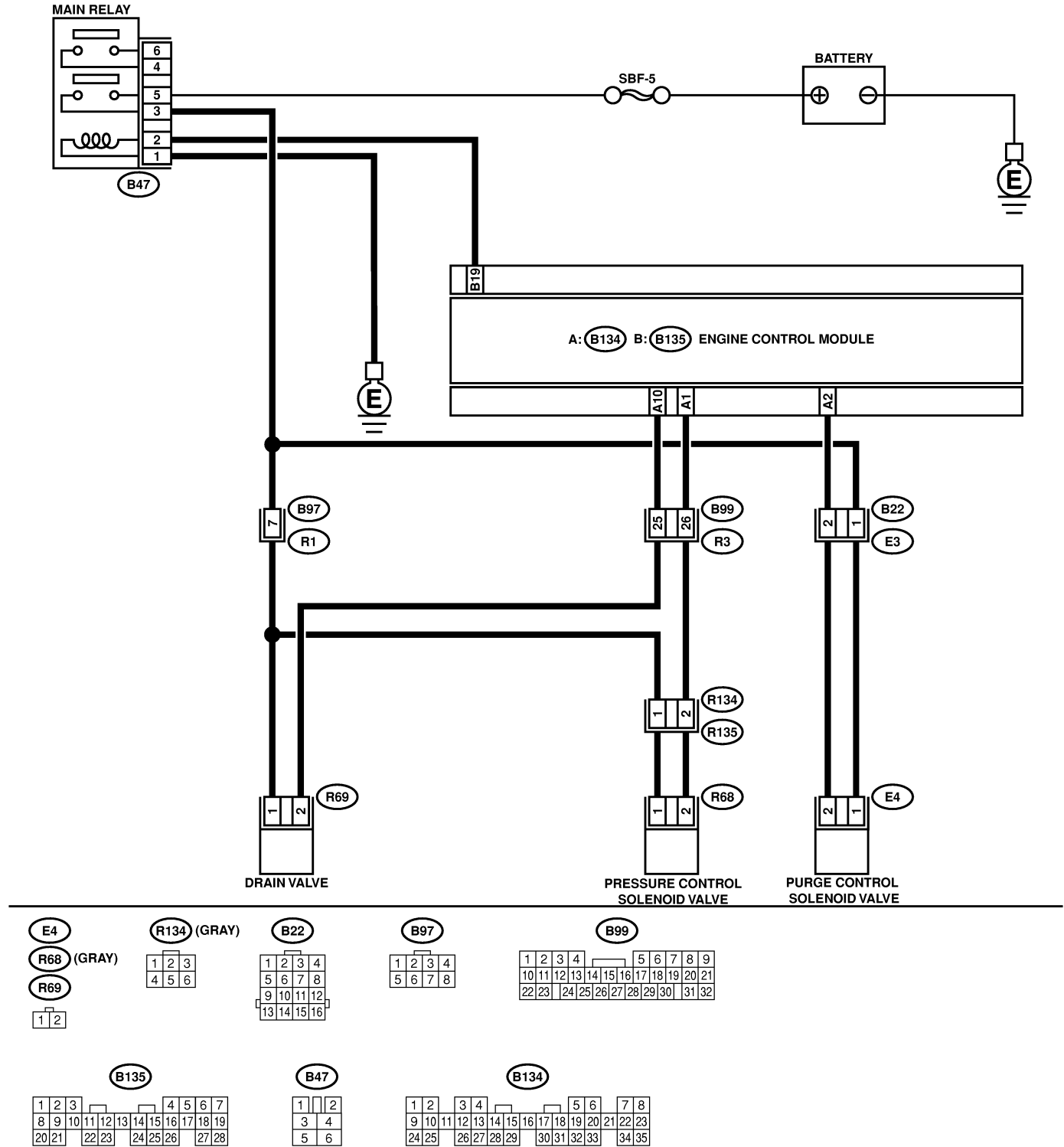

B2M4645

DIAGNOSTIC PROCEDURE WITH DIAGNOSTIC TROUBLE CODE (DTC)

Engine (Diagnostics)

No.	Step	Check	Yes	No
1	CHECK ANY OTHER DTC ON DISPLAY.	Is any other DTC displayed?	Inspect the relevant DTC using "List of Diagnostic Trouble Code (DTC)". <Ref. to EN-88, List of Diagnostic Trouble Code (DTC).>	Go to step 2.
2	CHECK FUEL FILLER CAP. 1) Turn ignition switch to OFF. 2) Check the fuel filler cap. NOTE: The DTC code is stored in memory if fuel filler cap is or was loose or if the cap chain was caught while tightening.	Is the fuel filler cap tightened securely?	Go to step 3.	Tighten fuel filler cap securely.
3	CHECK FUEL FILLER PIPE PACKING.	Is there any damage to the seal between fuel filler cap and fuel filler pipe?	Repair or replace fuel filler cap and fuel filler pipe. <Ref. to FU-65, Fuel Filler Pipe.>	Go to step 4.
4	CHECK DRAIN VALVE. 1) Connect test mode connector. 2) Turn ignition switch to ON. 3) Operate drain valve. NOTE: Drain valve operation can also be executed using Subaru Select Monitor. For the procedure, refer to "Compulsory Valve Operation Check Mode". <Ref. to EN-56, Compulsory Valve Operation Check Mode.>	Does drain valve produce operating sound?	Go to step 5.	Replace drain valve. <Ref. to EC-16, Drain Valve.>
5	CHECK PURGE CONTROL SOLENOID VALVE. Operate purge control solenoid valve. NOTE: Purge control solenoid valve operation can also be executed using Subaru Select Monitor. For the procedure, refer to "Compulsory Valve Operation Check Mode". <Ref. to EN-56, Compulsory Valve Operation Check Mode.>	Does purge control solenoid valve produce operating sound?	Go to step 6.	Replace purge control solenoid valve. <Ref. to EC-6, Purge Control Solenoid Valve.>
6	CHECK PRESSURE CONTROL SOLENOID VALVE. Operate pressure control solenoid valve. NOTE: Pressure control solenoid valve operation can also be executed using Subaru Select Monitor. For the procedure, refer to "Compulsory Valve Operation Check Mode". <Ref. to EN-56, Compulsory Valve Operation Check Mode.>	Does pressure control solenoid valve produce operating sound?	Go to step 7.	Replace pressure control solenoid valve. <Ref. to EC-12, Pressure Control Solenoid Valve.>
7	CHECK EVAPORATIVE EMISSION CONTROL SYSTEM LINE. Turn ignition switch to OFF.	Is there a hole of more than 0.5 mm (0.020 in) dia. on fuel line?	Repair or replace fuel line. <Ref. to FU-81, Fuel Delivery, Return and Evaporation Lines.>	Go to step 8.
8	CHECK CANISTER.	Is canister damaged or is there a hole of more than 0.5 mm (0.020 in) dia. in it?	Repair or replace canister. <Ref. to EC-5, Canister.>	Go to step 9.

DIAGNOSTIC PROCEDURE WITH DIAGNOSTIC TROUBLE CODE (DTC)

Engine (Diagnostics)

No.	Step	Check	Yes	No
9	CHECK FUEL TANK. Remove fuel tank. <Ref. to FU-57, Fuel Tank.>	Is fuel tank damaged or is there a hole of more than 0.5 mm (0.020 in) dia. in it?	Repair or replace fuel tank. <Ref. to FU-57, Fuel Tank.>	Go to step 10.
10	CHECK ANY OTHER MECHANICAL TROUBLE IN EVAPORATIVE EMISSION CONTROL SYSTEM.	Are there holes of more than 0.5 mm (0.020 in) dia., cracks, clogging or disconnections of hoses or pipes in evaporative emission control system?	Repair or replace hoses or pipes.	Contact with SOA (distributor) service. NOTE: Inspection by DTM is required, because probable cause is deterioration of multiple parts.

DIAGNOSTIC PROCEDURE WITH DIAGNOSTIC TROUBLE CODE (DTC)

Engine (Diagnostics)

AZ: DTC P0458 — EVAPORATIVE EMISSION CONTROL SYSTEM PURGE CONTROL VALVE CIRCUIT LOW INPUT — S078521K06

- **DTC DETECTING CONDITION:**
 - Two consecutive driving cycles with fault
- **TROUBLE SYMPTOM:**
 - Erroneous idling

CAUTION:

After repair or replacement of faulty parts, conduct Clear Memory Mode <Ref. to EN-55, OPERATION, Clear Memory Mode.> and Inspection Mode <Ref. to EN-48, OPERATION, Inspection Mode.>.

● WIRING DIAGRAM:

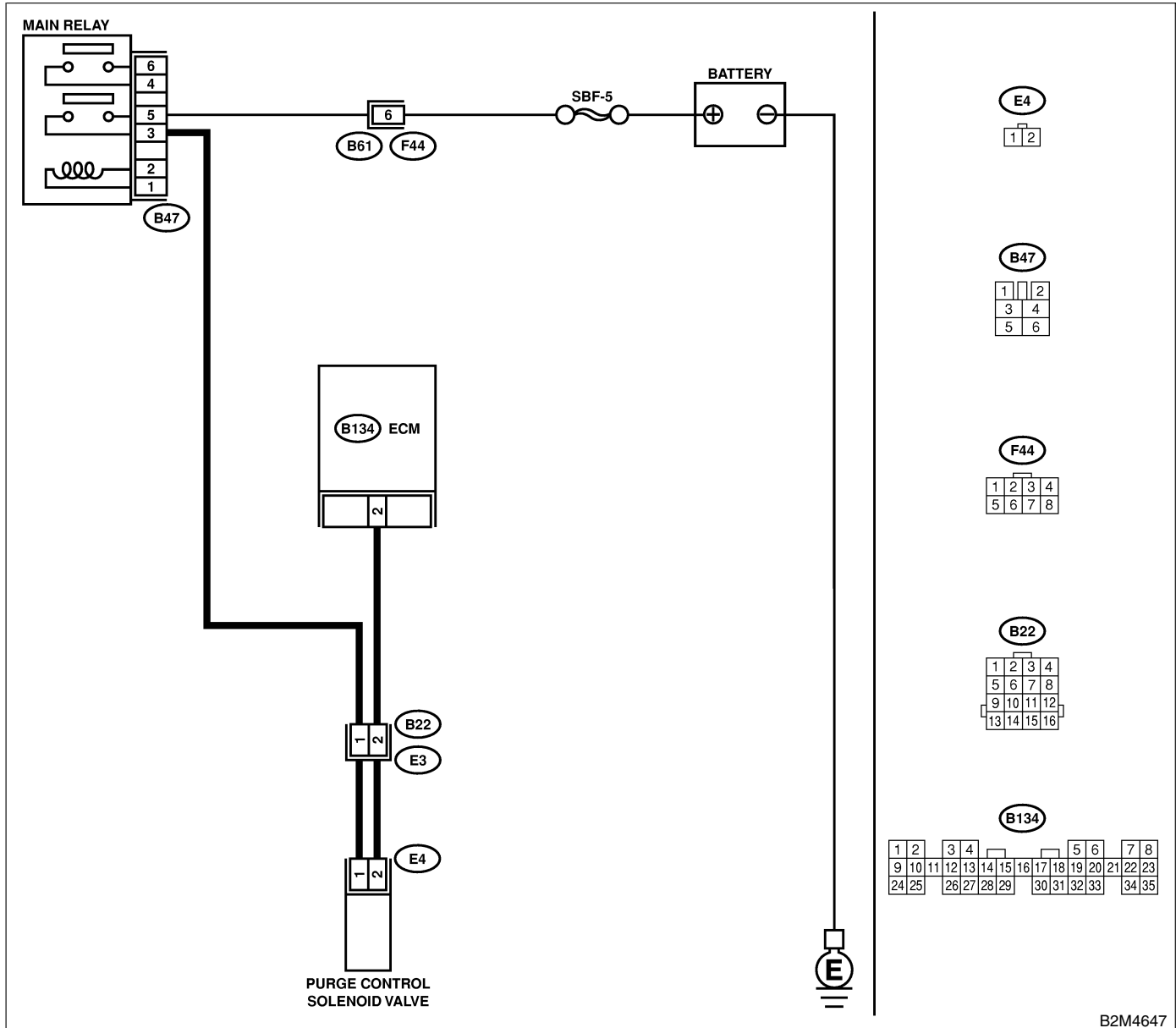

B2M4647

DIAGNOSTIC PROCEDURE WITH DIAGNOSTIC TROUBLE CODE (DTC)

Engine (Diagnostics)

No.	Step	Check	Yes	No
1	<p>CHECK OUTPUT SIGNAL FROM ECM. 1) Turn ignition switch to ON. 2) Measure voltage between ECM and chassis ground. Connector & terminal <i>(B134) No. 2 (+) — Chassis ground (-):</i></p>	Is the voltage more than 10 V?	Even if MIL lights up, the circuit has returned to a normal condition at this time. Contact with SOA (distributor) service. NOTE: Inspection by DTM is required, because probable cause is deterioration of multiple parts.	Go to step 2.
2	<p>CHECK HARNESS BETWEEN PURGE CONTROL SOLENOID VALVE AND ECM CONNECTOR. 1) Turn ignition switch to OFF. 2) Disconnect connectors from purge control solenoid valve and ECM. 3) Measure resistance of harness between purge control solenoid valve connector and engine ground. Connector & terminal <i>(E4) No. 2 — Engine ground:</i></p>	Is the resistance less than 10 Ω?	Repair ground short circuit in harness between ECM and purge control solenoid valve connector.	Go to step 3.
3	<p>CHECK HARNESS BETWEEN PURGE CONTROL SOLENOID VALVE AND ECM CONNECTOR. Measure resistance of harness between ECM and purge control solenoid valve of harness connector. Connector & terminal <i>(B134) No. 2 — (E4) No. 2:</i></p>	Is the resistance less than 1 Ω?	Go to step 4.	Repair open circuit in harness between ECM and purge control solenoid valve connector. NOTE: In this case, repair the following: <ul style="list-style-type: none"> ● Open circuit in harness between ECM and purge control solenoid valve connector ● Poor contact in coupling connector
4	<p>CHECK PURGE CONTROL SOLENOID VALVE. 1) Remove purge control solenoid valve. 2) Measure resistance between purge control solenoid valve terminals. Terminals <i>No. 1 — No. 2:</i></p>	Is the resistance between 10 and 100 Ω?	Go to step 5.	Replace purge control solenoid valve. <Ref. to EC-6, Purge Control Solenoid Valve.>
5	<p>CHECK POWER SUPPLY TO PURGE CONTROL SOLENOID VALVE. 1) Turn ignition switch to ON. 2) Measure voltage between purge control solenoid valve and engine ground. Connector & terminal <i>(E4) No. 1 (+) — Engine ground (-):</i></p>	Is the voltage more than 10 V?	Go to step 6.	Repair open circuit in harness between main relay and purge control solenoid valve connector.

DIAGNOSTIC PROCEDURE WITH DIAGNOSTIC TROUBLE CODE (DTC)

Engine (Diagnostics)

No.	Step	Check	Yes	No
6	CHECK POOR CONTACT. Check poor contact in purge control solenoid valve connector.	Is there poor contact in purge control solenoid valve connector?	Repair poor contact in purge control solenoid valve connector.	Contact with SOA (distributor) service. NOTE: Inspection by DTM is required, because probable cause is deterioration of multiple parts.

MEMO:

DIAGNOSTIC PROCEDURE WITH DIAGNOSTIC TROUBLE CODE (DTC)

Engine (Diagnostics)

BA: DTC P0459 — EVAPORATIVE EMISSION CONTROL SYSTEM PURGE CONTROL VALVE CIRCUIT HIGH INPUT — S078521K07

- **DTC DETECTING CONDITION:**
 - Two consecutive driving cycles with fault
- **TROUBLE SYMPTOM:**
 - Erroneous idling

CAUTION:

After repair or replacement of faulty parts, conduct Clear Memory Mode <Ref. to EN-55, OPERATION, Clear Memory Mode.> and Inspection Mode <Ref. to EN-48, OPERATION, Inspection Mode.>.

● WIRING DIAGRAM:

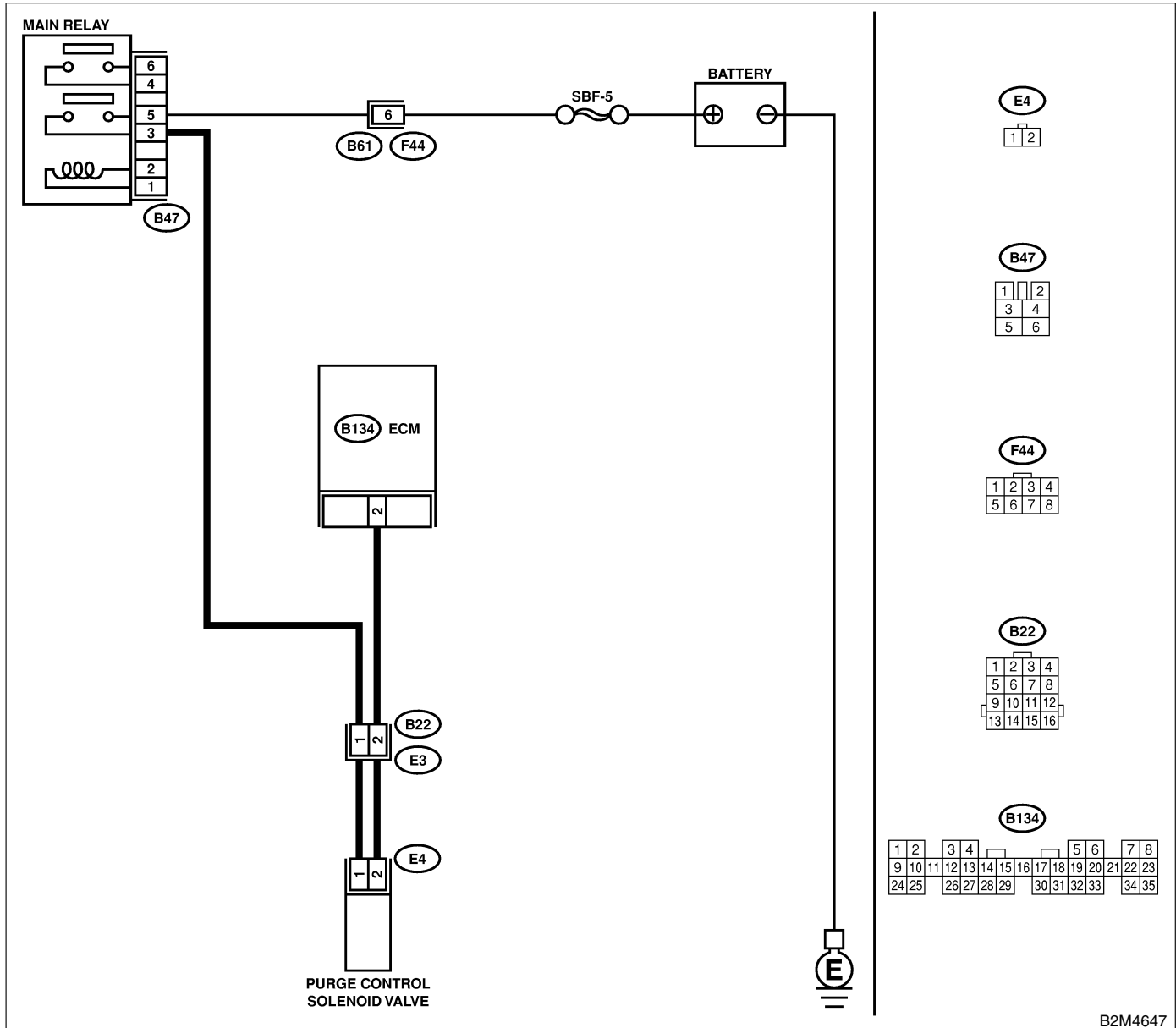

B2M4647

DIAGNOSTIC PROCEDURE WITH DIAGNOSTIC TROUBLE CODE (DTC)

Engine (Diagnostics)

No.	Step	Check	Yes	No
1	<p>CHECK OUTPUT SIGNAL FROM ECM.</p> <p>1) Turn ignition switch to OFF. 2) Connect test mode connector at the lower portion of instrument panel (on the driver's side), to the side of the center console box. 3) Turn ignition switch to ON. 4) While operating purge control solenoid valve, measure voltage between ECM and chassis ground.</p> <p>NOTE: Purge control solenoid valve operation can be executed using Subaru Select Monitor. For procedure, refer to "Compulsory Valve Operation Check Mode". <Ref. to EN-56, Compulsory Valve Operation Check Mode.></p> <p>Connector & terminal (B134) No. 2 (+) — Chassis ground (-):</p>	Does voltage change between 0 and 10 V?	Go to step 2.	Even if MIL light up, the circuit has returned to a normal condition at this time. In this case, repair poor contact in ECM connector.
2	<p>CHECK OUTPUT SIGNAL FROM ECM.</p> <p>1) Turn ignition switch to ON. 2) Measure voltage between ECM and chassis ground.</p> <p>Connector & terminal (B134) No. 2 (+) — Chassis ground (-):</p>	Is the voltage more than 10 V?	Go to step 4.	Go to step 3.
3	<p>CHECK POOR CONTACT.</p> <p>Check poor contact in ECM connector.</p>	Is there poor contact in ECM connector?	Repair poor contact in ECM connector.	Replace ECM. <Ref. to FU-51, Engine Control Module.>
4	<p>CHECK HARNESS BETWEEN PURGE CONTROL SOLENOID VALVE AND ECM CONNECTOR.</p> <p>1) Turn ignition switch to OFF. 2) Disconnect connector from purge control solenoid valve. 3) Turn ignition switch to ON. 4) Measure voltage between ECM and chassis ground.</p> <p>Connector & terminal (B134) No. 2 (+) — Chassis ground (-):</p>	Is the voltage more than 10 V?	Repair battery short circuit in harness between ECM and purge control solenoid valve connector. After repair, replace ECM. <Ref. to FU-51, Engine Control Module.>	Go to step 5.
5	<p>CHECK PURGE CONTROL SOLENOID VALVE.</p> <p>1) Turn ignition switch to OFF. 2) Measure resistance between purge control solenoid valve terminals.</p> <p>Terminals No. 1 — No. 2:</p>	Is the resistance less than 1 Ω ?	Replace purge control solenoid valve <Ref. to EC-6, Purge Control Solenoid Valve.> and ECM <Ref. to FU-51, Engine Control Module.>	Go to step 6.
6	<p>CHECK POOR CONTACT.</p> <p>Check poor contact in ECM connector.</p>	Is there poor contact in ECM connector?	Repair poor contact in ECM connector.	Replace ECM. <Ref. to FU-51, Engine Control Module.>

DIAGNOSTIC PROCEDURE WITH DIAGNOSTIC TROUBLE CODE (DTC)

Engine (Diagnostics)

BB: DTC P0462 — FUEL LEVEL SENSOR CIRCUIT LOW INPUT —

S078521B55

• DTC DETECTING CONDITION:

- Two consecutive driving cycles with fault

CAUTION:

After repair or replacement of faulty parts, conduct Clear Memory Mode <Ref. to EN-55, OPERATION, Clear Memory Mode.> and Inspection Mode <Ref. to EN-48, OPERATION, Inspection Mode.>.

• WIRING DIAGRAM:

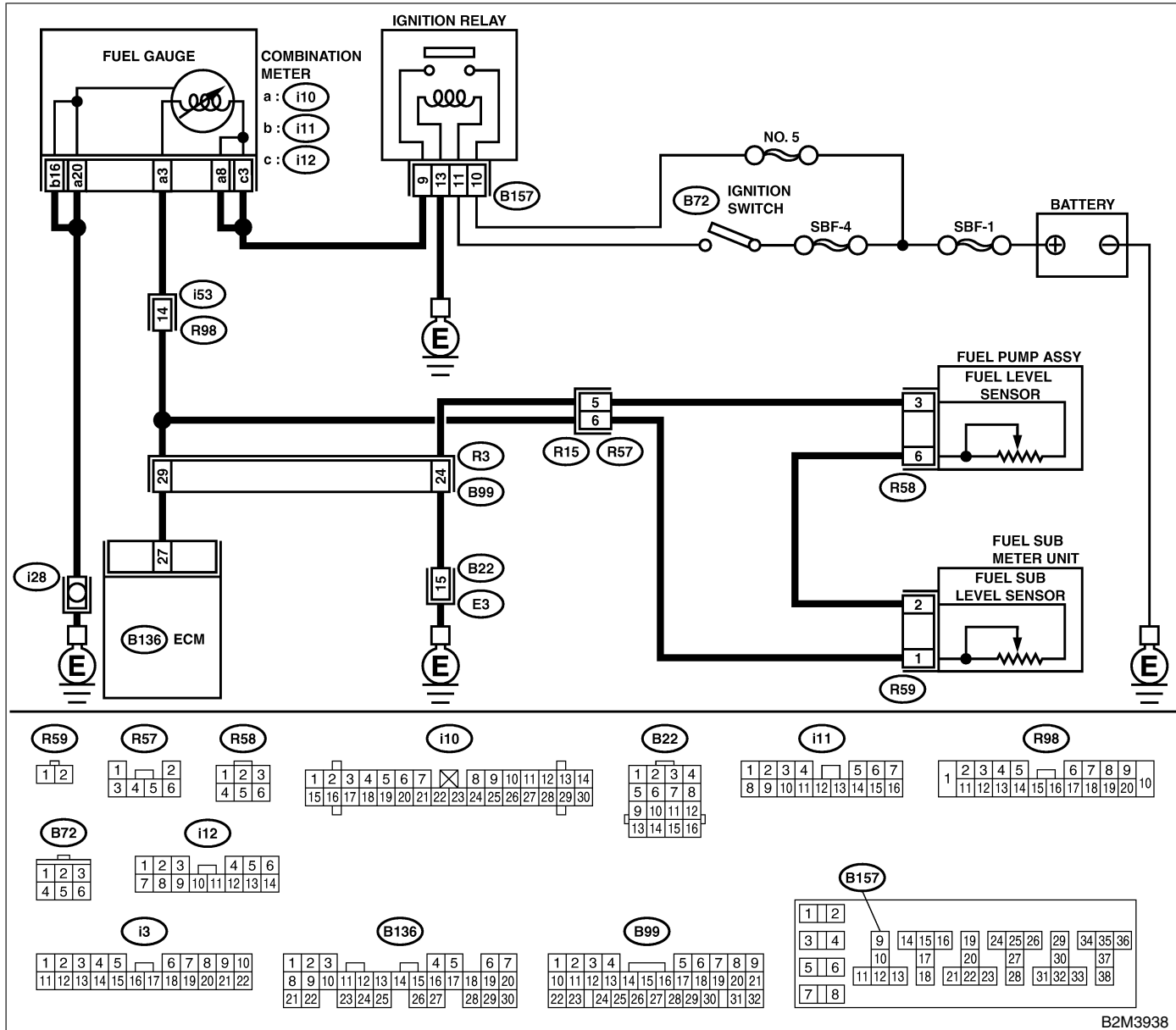

B2M3938

No.	Step	Check	Yes	No
1	CHECK SPEEDOMETER AND TACHOMETER OPERATION IN COMBINATION METER.	Does speedometer and tachometer operate normally?	Go to step 2.	Repair or replace combination meter. <Ref. to IDI-4, Combination Meter System.>

DIAGNOSTIC PROCEDURE WITH DIAGNOSTIC TROUBLE CODE (DTC)

Engine (Diagnostics)

No.	Step	Check	Yes	No
2	<p>CHECK INPUT SIGNAL FOR ECM. 1) Turn ignition switch to ON. (Engine OFF) 2) Measure voltage between ECM connector and chassis ground.</p> <p>Connector & terminal <i>(B136) No. 27 (+) — Chassis ground (-):</i></p>	Is the voltage less than 0.12 V?	Go to step 6.	Go to step 3.
3	<p>CHECK INPUT SIGNAL FOR ECM. (USING SUBARU SELECT MONITOR.) Read data of fuel level sensor signal using Subaru Select Monitor. NOTE: ● Subaru Select Monitor For detailed operation procedure, refer to the "READ CURRENT DATA FOR ENGINE". <Ref. to EN-36, Subaru Select Monitor.></p>	Does the value change less than 0.12 V by shaking harness and connector of ECM while monitoring the value with Subaru Select Monitor?	Repair poor contact in ECM connector.	Even if MIL lights up, the circuit has returned to a normal condition at this time. A temporary poor contact of the connector may be the cause. NOTE: In this case, repair the following: ● Poor contact in combination meter connector ● Poor contact in ECM connector ● Poor contact in coupling connectors
4	<p>CHECK INPUT VOLTAGE OF ECM. 1) Turn ignition switch to OFF. 2) Separate fuel tank cord connector (R57) and rear wiring harness connector (R15). 3) Turn ignition switch to ON. 4) Measure voltage of harness between ECM connector and chassis ground.</p> <p>Connector & terminal <i>(B136) No. 27 (+) — Chassis ground (-):</i></p>	Is the voltage more than 0.12 V?	Go to step 4.	Go to step 7.
5	<p>CHECK HARNESS BETWEEN ECM AND COMBINATION METER. 1) Turn ignition switch to OFF. 2) Disconnect connector from connector (i10) and ECM connector. 3) Measure resistance between ECM and chassis ground.</p> <p>Connector & terminal <i>(B136) No. 27 — Chassis ground:</i></p>	Is the resistance more than 1 MΩ?	Go to step 6.	Repair ground short circuit in harness between ECM and combination meter connector.
6	<p>CHECK HARNESS BETWEEN ECM AND COMBINATION METER. Measure resistance between ECM and combination meter connector.</p> <p>Connector & terminal <i>(B136) No. 27 — (i10) No. 3:</i></p>	Is the resistance less than 10 Ω?	Repair or replace combination meter. <Ref. to IDI-4, Combination Meter System.>	Repair open circuit between ECM and combination meter connector. NOTE: In this case, repair the following: Poor contact in coupling connector

DIAGNOSTIC PROCEDURE WITH DIAGNOSTIC TROUBLE CODE (DTC)

Engine (Diagnostics)

No.	Step	Check	Yes	No
7	CHECK FUEL TANK CORD. 1) Turn ignition switch to OFF. 2) Disconnect connector from fuel sub level sensor. 3) Measure resistance between fuel sub level sensor and chassis ground. Connector & terminal (R59) No. 1 — Chassis ground:	Is the resistance more than 1 M Ω ?	Go to step 8.	Repair ground short circuit in fuel tank cord.
8	CHECK FUEL TANK CORD. 1) Disconnect connector from fuel pump assembly. 2) Measure resistance between fuel pump assembly and chassis ground. Connector & terminal (R59) No. 2 — Chassis ground:	Is the resistance more than 1 M Ω ?	Go to step 9.	Repair ground short circuit in fuel tank cord.
9	CHECK FUEL LEVEL SENSOR. WARNING: During work procedures, if fuel tank is more than 3/4 full, be careful because fuel may spill. 1) Remove fuel pump assembly. <Ref. to FU-73, Fuel Pump.> 2) Measure resistance between fuel level sensor and terminals with its float set to the full position. Terminals No. 3 — No. 6:	Is the resistance between 0.5 and 2.5 Ω ?	Go to step 10.	Replace fuel level sensor.
10	CHECK FUEL SUB LEVEL SENSOR. WARNING: During work procedures, if fuel tank is more than 3/4 full, be careful because fuel may spill. 1) Remove fuel sub level sensor. <Ref. to FU-77, Fuel Sub Level Sensor.> 2) Measure resistance between fuel sub level sensor and terminals with its float set to the full position. Terminals No. 1 — No. 2:	Is the resistance between 0.5 and 2.5 Ω ?	Repair poor contact in harness between ECM and combination meter connector.	Replace fuel sub level sensor.

MEMO:

DIAGNOSTIC PROCEDURE WITH DIAGNOSTIC TROUBLE CODE (DTC)

Engine (Diagnostics)

BC: DTC P0463 — FUEL LEVEL SENSOR CIRCUIT HIGH INPUT — S078521B56

• DTC DETECTING CONDITION:

- Two consecutive driving cycles with fault

CAUTION:

After repair or replacement of faulty parts, conduct Clear Memory Mode <Ref. to EN-55, OPERATION, Clear Memory Mode.> and Inspection Mode <Ref. to EN-48, OPERATION, Inspection Mode.>.

• WIRING DIAGRAM:

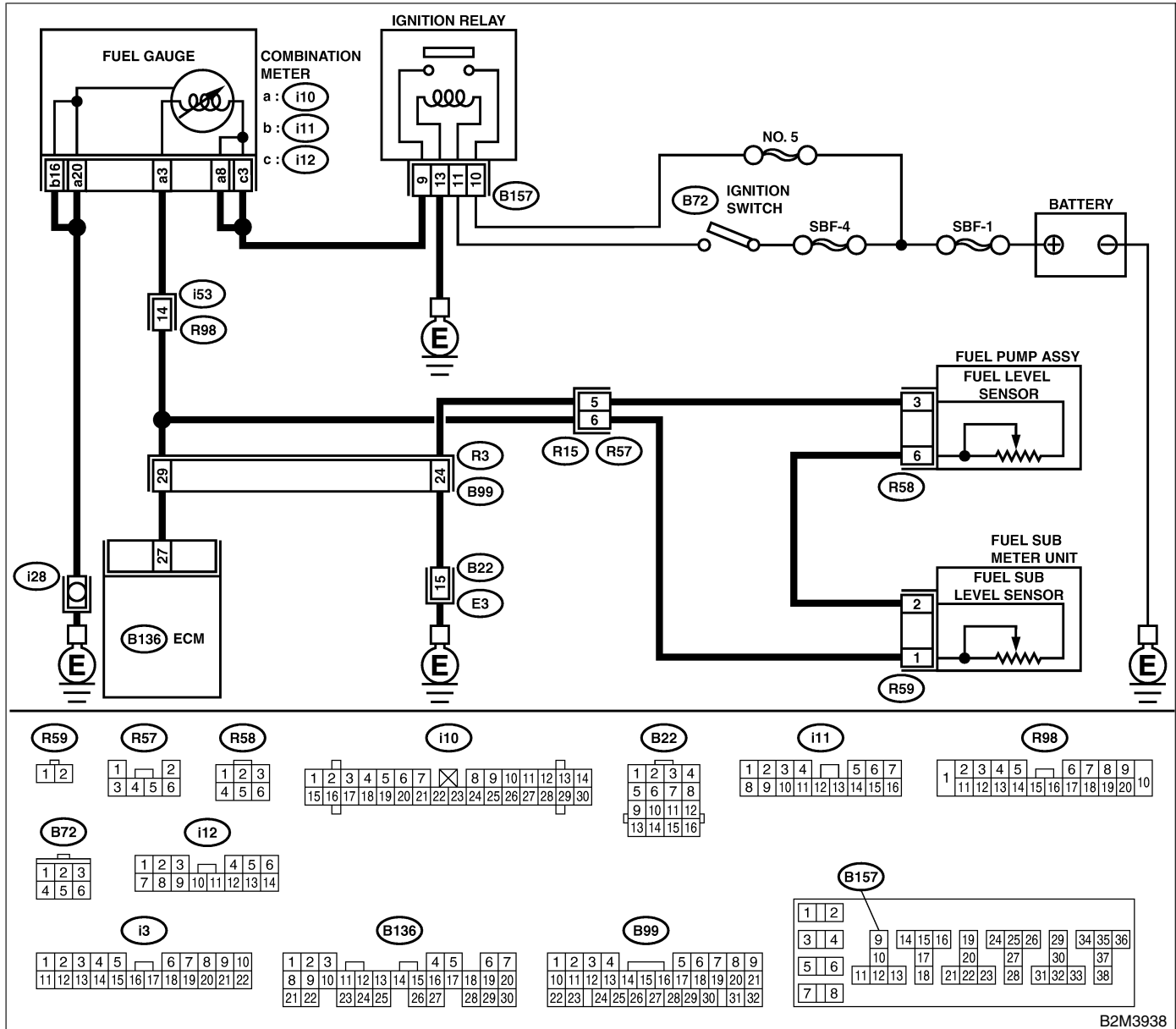

B2M3938

No.	Step	Check	Yes	No
1	CHECK SPEEDOMETER AND TACHOMETER OPERATION IN COMBINATION METER.	Does speedometer and tachometer operate normally?	Go to step 2.	Repair or replace combination meter. <Ref. to IDI-4, Combination Meter System.>

DIAGNOSTIC PROCEDURE WITH DIAGNOSTIC TROUBLE CODE (DTC)

Engine (Diagnostics)

No.	Step	Check	Yes	No
2	<p>CHECK INPUT SIGNAL FOR ECM. 1) Turn ignition switch to ON. (Engine OFF) 2) Measure voltage between ECM connector and chassis ground. Connector & terminal (B136) No. 27 (+) — Chassis ground (-):</p>	Is the voltage more than 4.75 V?	Go to step 3.	Even if MIL lights up, the circuit has returned to a normal condition at this time. A temporary poor contact of the connector may be the cause. NOTE: In this case, repair the following: <ul style="list-style-type: none"> ● Poor contact in fuel pump connector ● Poor contact in coupling connector
3	<p>CHECK INPUT VOLTAGE OF ECM. 1) Turn ignition switch to OFF. 2) Disconnect combination meter connector (i10) and ECM connector. 3) Turn ignition switch to ON. 4) Measure voltage of harness between ECM and chassis ground. Connector & terminal (B136) No. 27 (+) — Chassis ground (-):</p>	Is the voltage more than 4.75 V?	Go to step 4.	Repair battery short circuit between ECM and combination meter connector.
4	<p>CHECK HARNESS BETWEEN ECM AND FUEL TANK CORD. 1) Turn ignition switch to OFF. 2) Separate fuel tank cord connector (R57) and rear wiring harness connector (R15). 3) Measure resistance between ECM and fuel tank cord. Connector & terminal (B136) No. 27 — (R15) No. 6:</p>	Is the resistance less than 5 Ω?	Go to step 5.	Repair open circuit between ECM and fuel tank cord.
5	<p>CHECK HARNESS BETWEEN FUEL TANK CORD AND CHASSIS GROUND. Measure resistance between fuel tank cord and chassis ground. Connector & terminal (R15) No. 5 — Chassis ground:</p>	Is the resistance less than 5 Ω?	Go to step 6.	Repair open circuit between fuel tank cord and chassis ground. NOTE: In this case, repair the following: Poor contact in coupling connectors
6	<p>CHECK FUEL TANK CORD. 1) Disconnect connector from fuel level sensor. 2) Measure resistance between fuel level sensor and coupling connector. Connector & terminal (R57) No. 5 — (R58) No. 3:</p>	Is the resistance less than 10 Ω?	Go to step 7.	Repair open circuit between coupling connector and fuel level sensor.

DIAGNOSTIC PROCEDURE WITH DIAGNOSTIC TROUBLE CODE (DTC)

Engine (Diagnostics)

No.	Step	Check	Yes	No
7	<p>CHECK FUEL TANK CORD.</p> <p>1) Disconnect connector from fuel sub level sensor.</p> <p>2) Measure resistance between fuel level sensor and fuel sub level sensor.</p> <p>Connector & terminal (R58) No. 6 — (R59) No. 2:</p>	Is the resistance less than 10 Ω?	Go to step 8.	Repair open circuit between fuel level sensor and fuel sub level sensor.
8	<p>CHECK FUEL TANK CORD.</p> <p>Measure resistance between fuel sub level sensor and coupling connector.</p> <p>Connector & terminal (R57) No. 6 — (R59) No. 1:</p>	Is the resistance less than 10 Ω?	Go to step 9.	Repair open circuit between coupling connector and fuel sub level sensor.
9	<p>CHECK FUEL LEVEL SENSOR.</p> <p>WARNING: During work procedures, if fuel tank is more than 3/4 full, be careful because fuel may spill.</p> <p>1) Remove fuel pump assembly. <Ref. to FU-73, Fuel Pump.></p> <p>2) While moving fuel level sensor float up and down, measure resistance between fuel level sensor terminals.</p> <p>Terminals No. 3 — No. 6:</p>	Is the resistance more than 54.5 Ω?	Replace fuel level sensor. <Ref. to FU-76, Fuel Level Sensor.>	Go to step 10.
10	<p>CHECK FUEL SUB LEVEL SENSOR.</p> <p>WARNING: During work procedures, if fuel tank is more than 3/4 full, be careful because fuel may spill.</p> <p>1) Remove fuel sub level sensor. <Ref. to FU-77, Fuel Sub Level Sensor.></p> <p>2) While moving fuel sub level sensor float up and down, measure resistance between fuel sub level sensor terminals.</p> <p>Terminals No. 1 — No. 2:</p>	Is the resistance more than 41.5 Ω?	Replace fuel sub level sensor. <Ref. to FU-77, Fuel Sub Level Sensor.>	Replace combination meter. <Ref. to IDI-11, Combination Meter Assembly.>

MEMO:

DIAGNOSTIC PROCEDURE WITH DIAGNOSTIC TROUBLE CODE (DTC)

Engine (Diagnostics)

BD: DTC P0464 — FUEL LEVEL SENSOR INTERMITTENT INPUT— S078521G01

• DTC DETECTING CONDITION:

- Two consecutive driving cycles with fault

CAUTION:

After repair or replacement of faulty parts, conduct Clear Memory Mode <Ref. to EN-55, OPERATION, Clear Memory Mode.> and Inspection Mode <Ref. to EN-48, OPERATION, Inspection Mode.>.

• WIRING DIAGRAM:

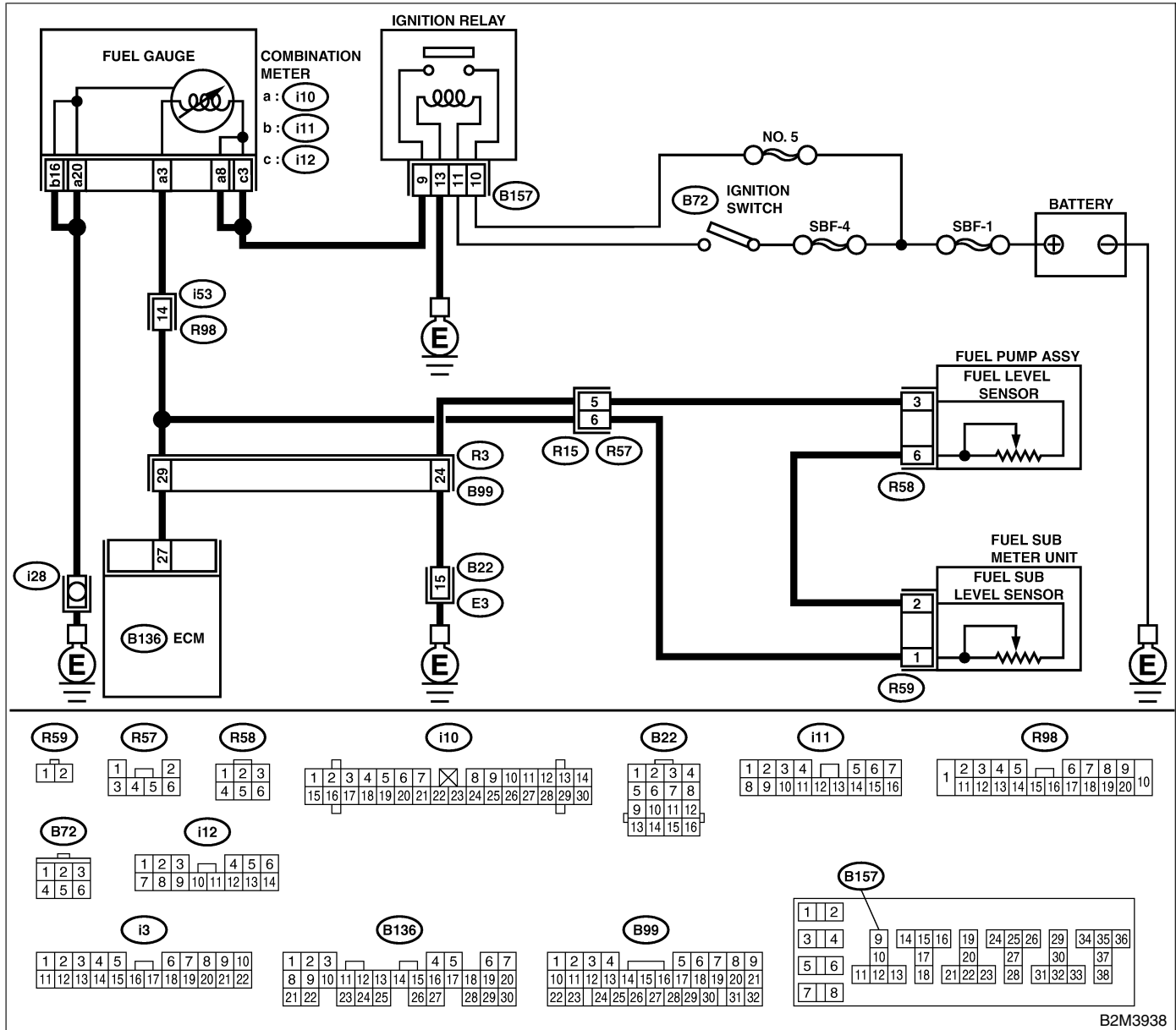

B2M3938

No.	Step	Check	Yes	No
1	CHECK ANY OTHER DTC ON DISPLAY.	Is any other DTC displayed?	Inspect the relevant DTC using "List of Diagnostic Trouble Code (DTC)". <Ref. to EN-88, List of Diagnostic Trouble Code (DTC).>	Go to step 2.

DIAGNOSTIC PROCEDURE WITH DIAGNOSTIC TROUBLE CODE (DTC)

Engine (Diagnostics)

No.	Step	Check	Yes	No
2	<p>CHECK FUEL LEVEL SENSOR. WARNING: During work procedures, if fuel tank is more than 3/4 full, be careful because fuel may spill. 1) Remove fuel pump assembly. <Ref. to FU-73, Fuel Pump.> 2) While moving fuel level sensor float up and down, make sure that the resistance between fuel level sensor terminals changes smoothly. Terminals No. 3 — No. 6:</p>	Does the resistance change smoothly?	Go to step 3.	Replace fuel level sensor. <Ref. to FU-76, Fuel Level Sensor.>
3	<p>CHECK FUEL SUB LEVEL SENSOR. WARNING: During work procedures, if fuel tank is more than 3/4 full, be careful because fuel may spill. 1) Remove fuel sub level sensor. <Ref. to FU-77, Fuel Sub Level Sensor.> 2) While moving fuel sub level sensor float up and down, make sure that the resistance between fuel level sensor terminals changes smoothly. Terminals No. 1 — No. 2:</p>	Does the resistance change smoothly?	Repair poor contact in ECM, combination meter and coupling connectors.	Replace fuel sub level sensor. <Ref. to FU-77, Fuel Sub Level Sensor.>

DIAGNOSTIC PROCEDURE WITH DIAGNOSTIC TROUBLE CODE (DTC)

Engine (Diagnostics)

BE: DTC P0483 — COOLING FAN FUNCTION PROBLEM — S078521B58

- **DTC DETECTING CONDITION:**
 - Two consecutive driving cycles with fault
- **TROUBLE SYMPTOM:**
 - Occurrence of noise
 - Overheating

CAUTION:

After repair or replacement of faulty parts, conduct Clear Memory Mode <Ref. to EN-55, OPERATION, Clear Memory Mode.> and Inspection Mode <Ref. to EN-48, OPERATION, Inspection Mode.>.

NOTE:

If the vehicle, with the engine idling, is placed very close to a wall or another vehicle, preventing normal cooling function, the OBD system may detect malfunction.

DIAGNOSTIC PROCEDURE WITH DIAGNOSTIC TROUBLE CODE (DTC) Engine (Diagnostics)

● WIRING DIAGRAM:

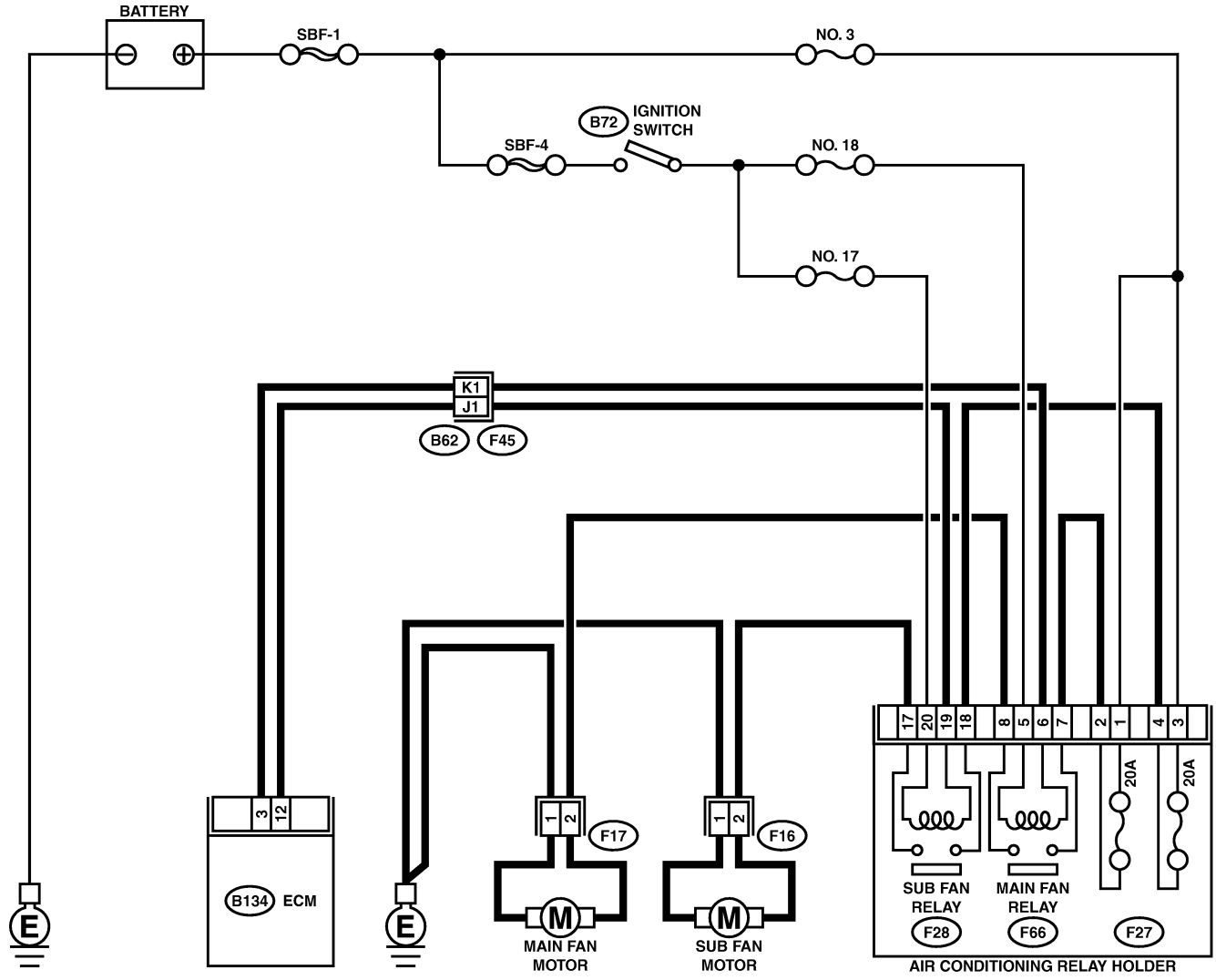

B72 (BLUE)



F27 F66

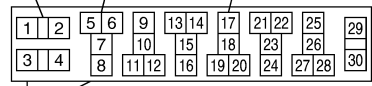

F28

B134

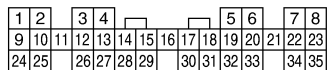

B62

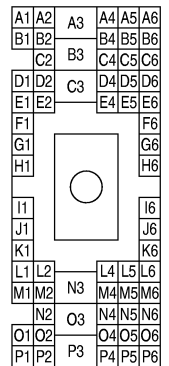

B2M3939

DIAGNOSTIC PROCEDURE WITH DIAGNOSTIC TROUBLE CODE (DTC)

Engine (Diagnostics)

No.	Step	Check	Yes	No
1	CHECK ANY OTHER DTC ON DISPLAY.	Is any other DTC displayed?	Inspect the relevant DTC using "List of Diagnostic Trouble Code (DTC)". <Ref. to EN-88, List of Diagnostic Trouble Code (DTC).>	Check radiator fan and fan motor. <Ref. to CO-26, INSPECTION, Radiator Main Fan and Fan Motor.> and <Ref. to CO-29, INSPECTION, Radiator Sub Fan and Fan Motor.>

MEMO:

DIAGNOSTIC PROCEDURE WITH DIAGNOSTIC TROUBLE CODE (DTC)

Engine (Diagnostics)

No.	Step	Check	Yes	No
2	CHECK DTC P0720 ON DISPLAY.	Does the Subaru Select Monitor or OBD-II general scan tool indicate DTC P0720?	Check front vehicle speed sensor signal circuit. <Ref. to AT-60, DTC 33 FRONT VEHICLE SPEED SENSOR, Diagnostic Procedure with Trouble Code (DTC).>	Go to step 3.
3	CHECK SPEEDOMETER OPERATION IN COMBINATION METER.	Does speedometer operate normally?	Go to step 4.	Check speedometer and vehicle speed sensor. <Ref. to IDI-13, Speedometer.> and <Ref. to AT-33, Front Vehicle Speed Sensor.> and <Ref. to AT-37, Rear Vehicle Speed Sensor.> and <Ref. to AT-38, Torque Converter Turbine Speed Sensor.>
4	CHECK HARNESS BETWEEN ECM AND COMBINATION METER CONNECTOR. 1) Turn ignition switch to OFF. 2) Disconnect connector from combination meter. 3) Measure resistance between ECM and combination meter. Connector & terminal (B135) No. 24 — (i10) No. 7:	Is the resistance less than 10 Ω?	Repair poor contact in ECM connector.	Repair harness and connector. NOTE: In this case, repair the following: ● Open circuit in harness between ECM and combination meter connector ● Poor contact in ECM connector ● Poor contact in combination meter connector ● Poor contact in coupling connector

DIAGNOSTIC PROCEDURE WITH DIAGNOSTIC TROUBLE CODE (DTC)

Engine (Diagnostics)

BG: DTC P0506 — IDLE CONTROL SYSTEM RPM LOWER THAN EXPECTED

S078521B61

- **DTC DETECTING CONDITION:**

- Two consecutive driving cycles with fault

- **TROUBLE SYMPTOM:**

- Engine is difficult to start.
- Engine does not start.
- Erroneous idling
- Engine stalls.

CAUTION:

After repair or replacement of faulty parts, conduct Clear Memory Mode <Ref. to EN-55, OPERATION, Clear Memory Mode.> and Inspection Mode <Ref. to EN-48, OPERATION, Inspection Mode.>.

- **WIRING DIAGRAM:**

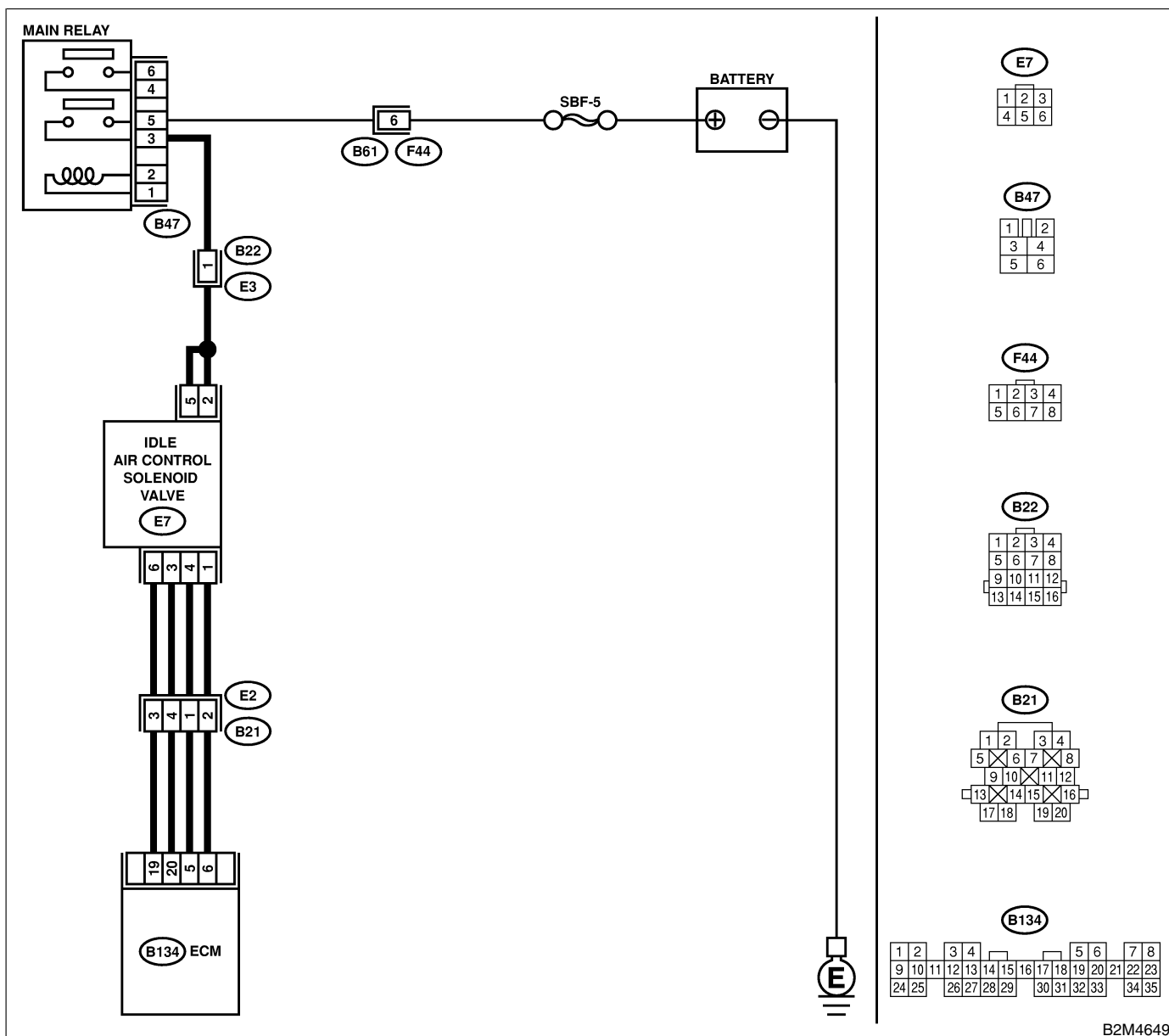

B2M4649

DIAGNOSTIC PROCEDURE WITH DIAGNOSTIC TROUBLE CODE (DTC)

Engine (Diagnostics)

No.	Step	Check	Yes	No
1	CHECK ANY OTHER DTC ON DISPLAY.	Is any other DTC displayed?	Inspect the relevant DTC using "List of Diagnostic Trouble Code (DTC)". <Ref. to EN-88, List of Diagnostic Trouble Code (DTC).> NOTE: In this case, it is not necessary to inspect DTC P0506.	Go to step 2.
2	CHECK AIR BY-PASS LINE. 1) Turn ignition switch to OFF. 2) Remove idle air control solenoid valve from throttle body. <Ref. to FU-39, REMOVAL, Idle Air Control Solenoid Valve.> 3) Remove throttle body from intake manifold. <Ref. to FU-14, REMOVAL, Throttle Body.> 4) Using an air gun, force air into idle air control solenoid valve installation area. Confirm that forced air subsequently escapes from throttle body interior.	Does air flow out?	Replace idle air control solenoid valve. <Ref. to FU-39, INSTALLATION, Idle Air Control Solenoid Valve.>	Replace throttle body. <Ref. to FU-14, INSTALLATION, Throttle Body.>

DIAGNOSTIC PROCEDURE WITH DIAGNOSTIC TROUBLE CODE (DTC)

Engine (Diagnostics)

BH: DTC P0507 — IDLE CONTROL SYSTEM RPM HIGHER THAN EXPECTED

S078521B62

● DTC DETECTING CONDITION:

- Two consecutive driving cycles with fault

● TROUBLE SYMPTOM:

- Engine keeps running at higher revolution than specified idling revolution.

CAUTION:

After repair or replacement of faulty parts, conduct Clear Memory Mode <Ref. to EN-55, OPERATION, Clear Memory Mode.> and Inspection Mode <Ref. to EN-48, OPERATION, Inspection Mode.>.

● WIRING DIAGRAM:

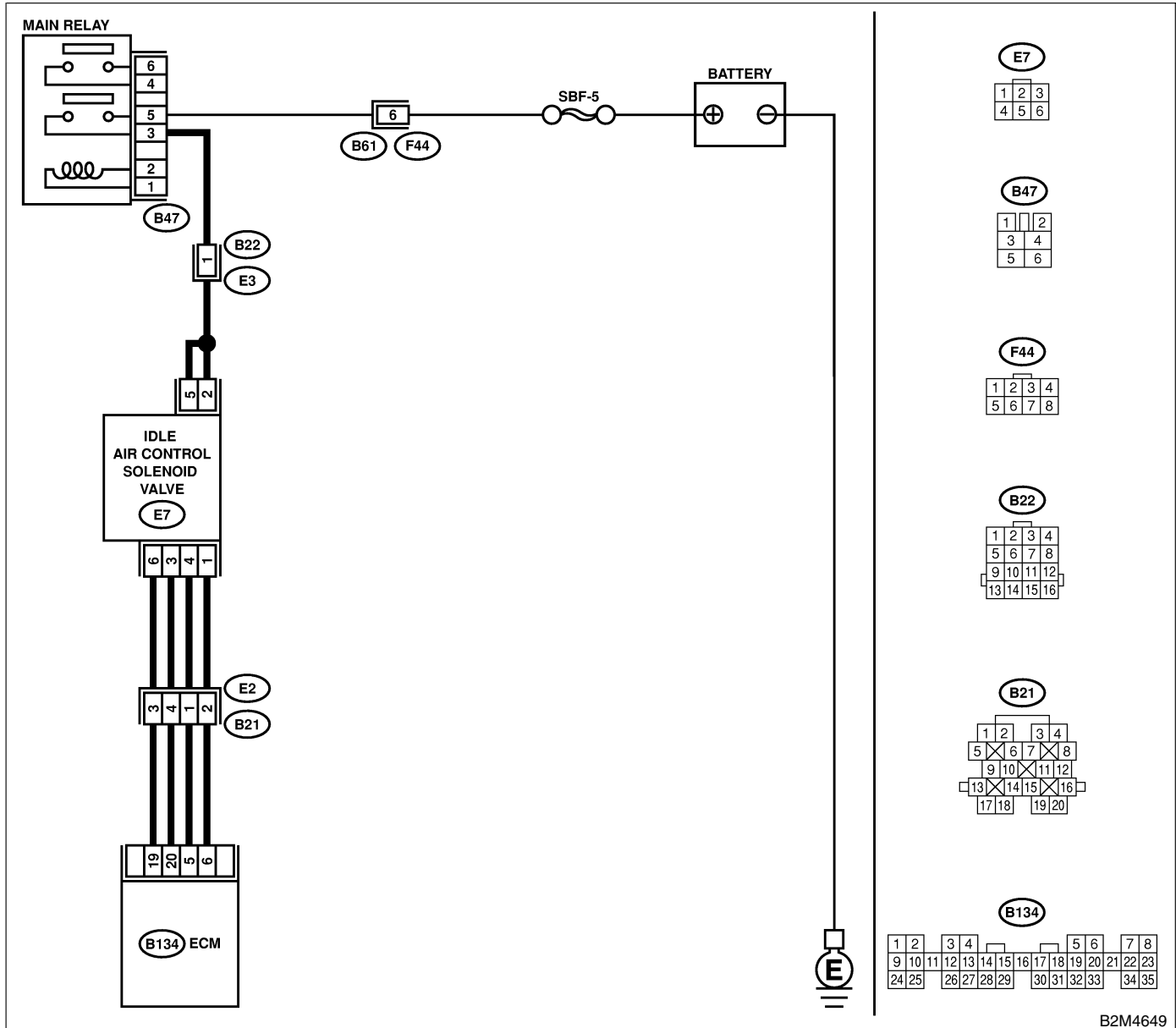

B2M4649

DIAGNOSTIC PROCEDURE WITH DIAGNOSTIC TROUBLE CODE (DTC)

Engine (Diagnostics)

No.	Step	Check	Yes	No
1	CHECK ANY OTHER DTC ON DISPLAY.	Is any other DTC displayed?	Inspect the relevant DTC using "List of Diagnostic Trouble Code (DTC)". <Ref. to EN-88, List of Diagnostic Trouble Code (DTC).> NOTE: In this case, it is not necessary to inspect DTC P0507.	Go to step 2.
2	CHECK AIR INTAKE SYSTEM. 1) Turn ignition switch to ON. 2) Start engine, and idle it. 3) Check the following items. ● Loose installation of intake manifold, idle air control solenoid valve and throttle body ● Cracks of intake manifold gasket, idle air control solenoid valve gasket and throttle body gasket ● Disconnections of vacuum hoses	Is there a fault in air intake system?	Repair air suction and leaks.	Go to step 3.
3	CHECK THROTTLE CABLE.	Does throttle cable have play for adjustment?	Go to step 4.	Adjust throttle cable. <Ref. to SP-6, INSTALLATION, Accelerator Control Cable.>
4	CHECK AIR BY-PASS LINE. 1) Turn ignition switch to OFF. 2) Remove idle air control solenoid valve from throttle body. <Ref. to FU-39, REMOVAL, Idle Air Control Solenoid Valve.> 3) Confirm that there are no foreign particles in by-pass air line.	Are foreign particles in by-pass air line?	Remove foreign particles from by-pass air line.	Replace idle air control solenoid valve. <Ref. to FU-39, Idle Air Control Solenoid Valve.>

DIAGNOSTIC PROCEDURE WITH DIAGNOSTIC TROUBLE CODE (DTC)

Engine (Diagnostics)

BI: DTC P0512 — STARTER SWITCH CIRCUIT HIGH INPUT — S078521G02

- **DTC DETECTING CONDITION:**
 - Two consecutive driving cycles with fault
- **TROUBLE SYMPTOM:**
 - Failure of engine to start

CAUTION:

After repair or replacement of faulty parts, conduct Clear Memory Mode <Ref. to EN-55, OPERATION, Clear Memory Mode.> and Inspection Mode <Ref. to EN-48, OPERATION, Inspection Mode.>.

DIAGNOSTIC PROCEDURE WITH DIAGNOSTIC TROUBLE CODE (DTC)

Engine (Diagnostics)

● WIRING DIAGRAM:

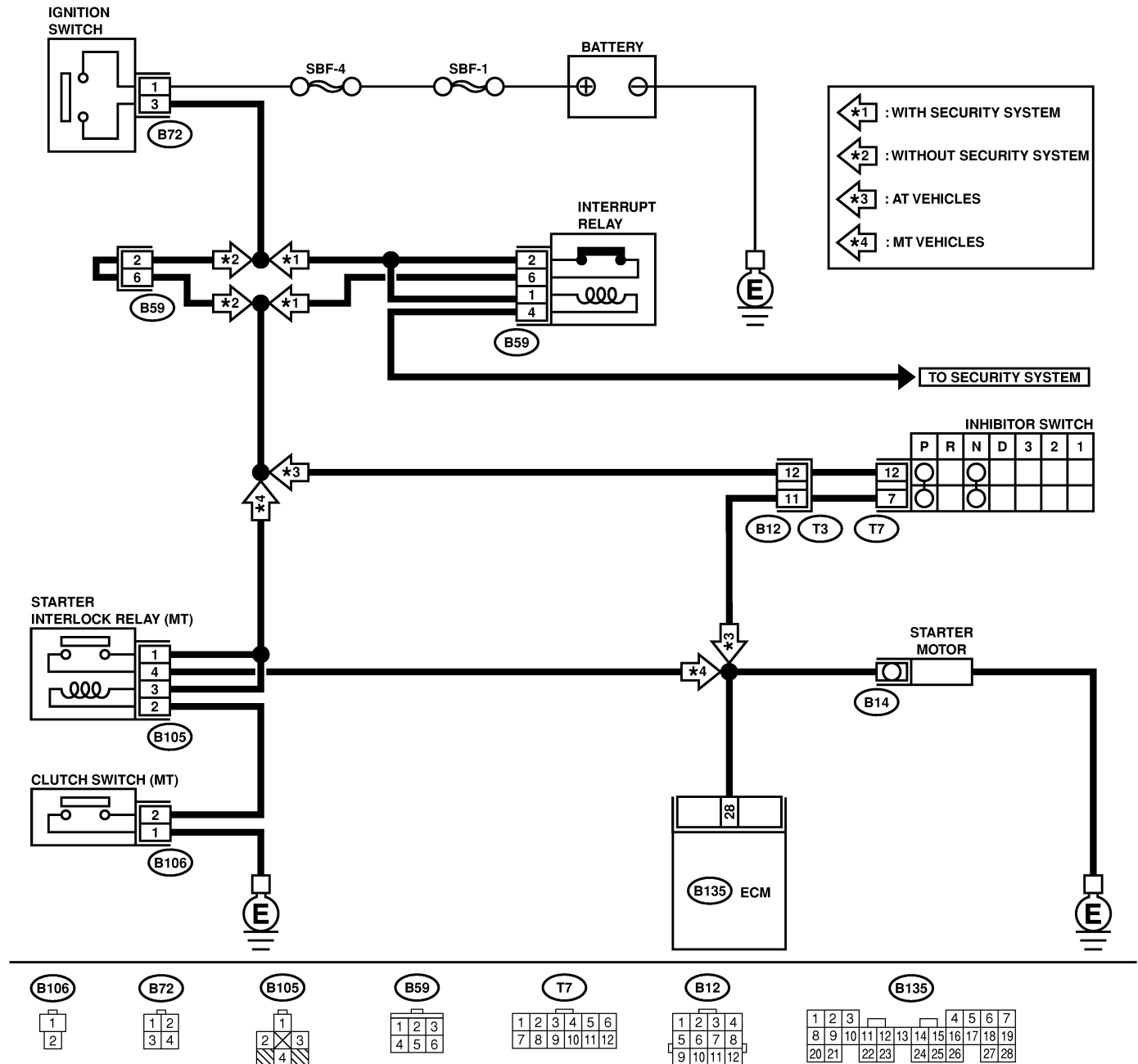

B2M4635

DIAGNOSTIC PROCEDURE WITH DIAGNOSTIC TROUBLE CODE (DTC)

Engine (Diagnostics)

No.	Step	Check	Yes	No
1	CHECK OPERATION OF STARTER MOTOR. NOTE: Place the inhibitor switch in each position.	Does starter motor operate when ignition switch to "ON"?	Repair battery short circuit in starter motor circuit.	Check starter motor circuit. <Ref. to EC-69, Diagnostics for Engine Starting Failure.>

BJ: DTC P0604 — INTERNAL CONTROL MODULE MEMORY CHECK SUM ERROR — S078521G03

- **DTC DETECTING CONDITION:**
 - Immediately at fault recognition
- **TROUBLE SYMPTOM:**
 - Engine does not start.
 - Engine stalls.

CAUTION:

After repair or replacement of faulty parts, conduct Clear Memory Mode <Ref. to EN-55, OPERATION, Clear Memory Mode.> and Inspection Mode <Ref. to EN-48, OPERATION, Inspection Mode.>.

● **WIRING DIAGRAM:**

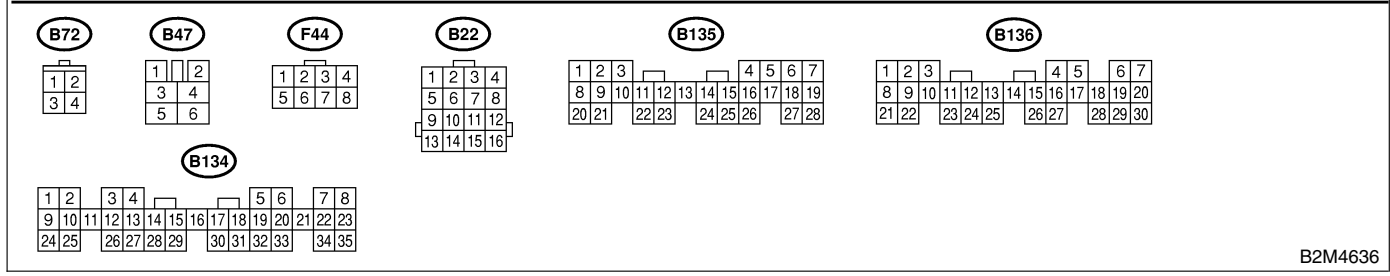
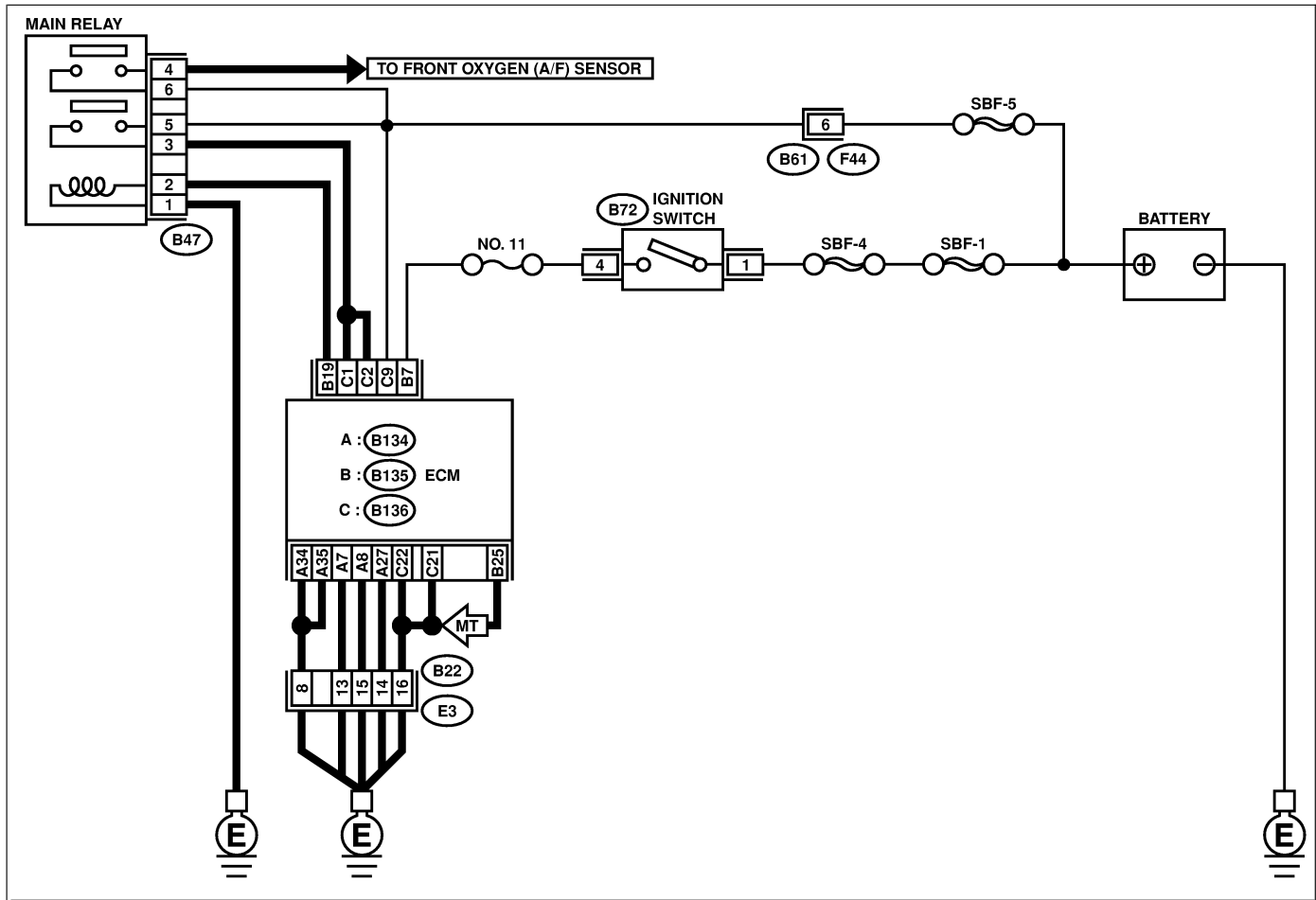

B2M4636

No.	Step	Check	Yes	No
1	CHECK ANY OTHER DTC ON DISPLAY.	Does the Subaru Select Monitor or OBD-II general scan tool indicate DTC P0601?	Replace ECM. <Ref. to FU-51, Engine Control Module.>	It is not necessary to inspect DTC P0601.

DIAGNOSTIC PROCEDURE WITH DIAGNOSTIC TROUBLE CODE (DTC)

Engine (Diagnostics)

BK: DTC P0691 — COOLING FAN RELAY 1 CIRCUIT LOW INPUT — S078521K19

- **DTC DETECTING CONDITION:**
 - Two consecutive driving cycles with fault
- **TROUBLE SYMPTOM:**
 - Radiator fan does not operate properly.
 - Overheating

CAUTION:

After repair or replacement of faulty parts, conduct Clear Memory Mode <Ref. to EN-55, OPERATION, Clear Memory Mode.> and Inspection Mode <Ref. to EN-48, OPERATION, Inspection Mode.>.

DIAGNOSTIC PROCEDURE WITH DIAGNOSTIC TROUBLE CODE (DTC)

Engine (Diagnostics)

● WIRING DIAGRAM:

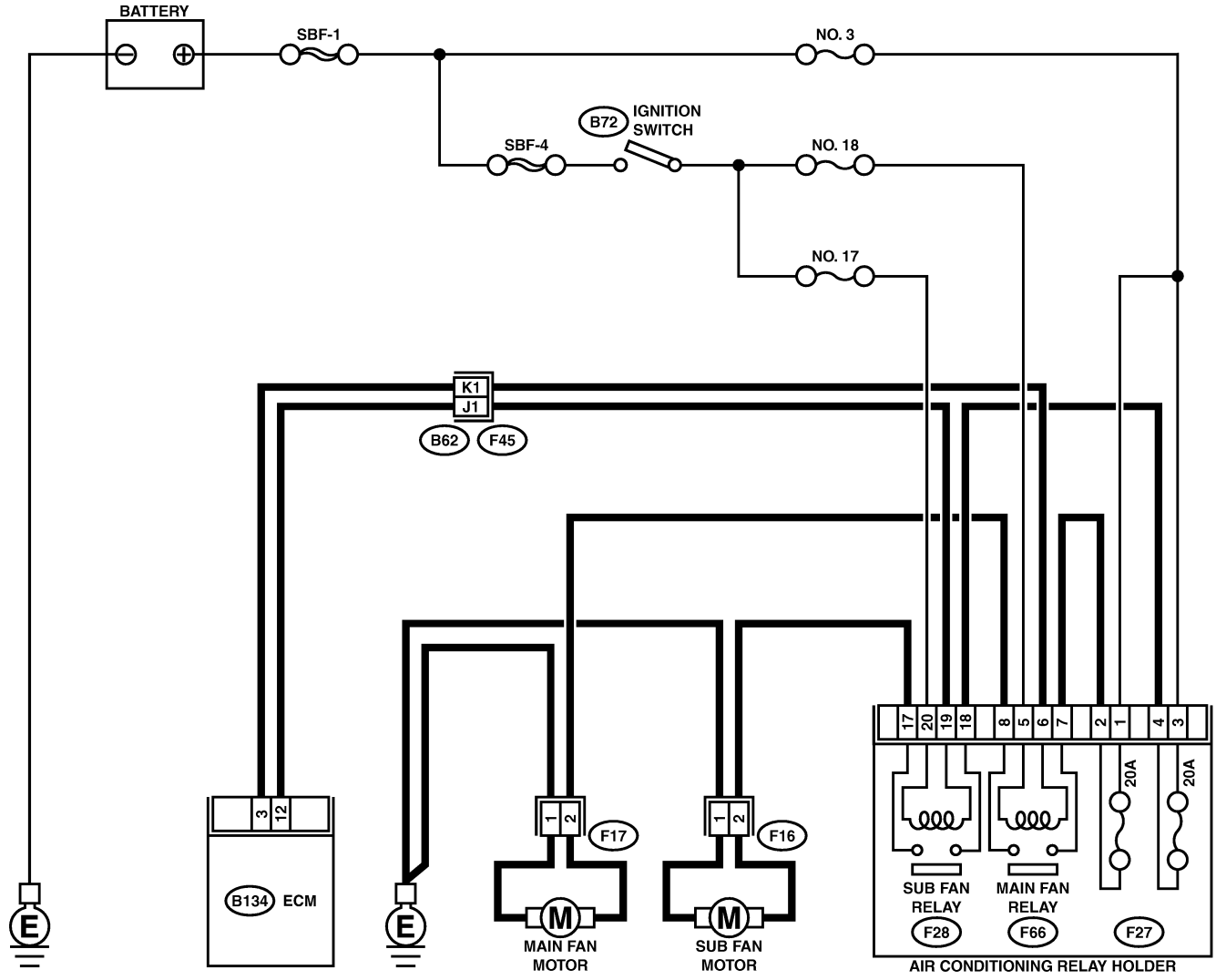

B72 (BLUE)



F27 **F66**

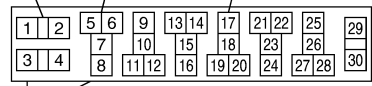

F28

B134

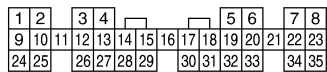

B62

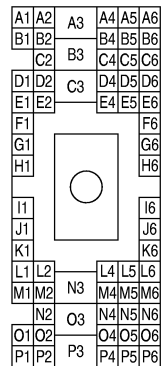

B2M3939

DIAGNOSTIC PROCEDURE WITH DIAGNOSTIC TROUBLE CODE (DTC)

Engine (Diagnostics)

No.	Step	Check	Yes	No
1	<p>CHECK OUTPUT SIGNAL FROM ECM.</p> <p>1) Turn ignition switch to OFF. 2) Connect test mode connector at the lower portion of instrument panel (on the driver's side), to the side of the center console box. 3) Turn ignition switch to ON. 4) While operating radiator fan relay, measure voltage between ECM terminal and ground.</p> <p>NOTE: Radiator fan relay operation can be executed using Subaru Select Monitor. For procedure, refer to "Compulsory Valve Operation Check Mode". <Ref. to EN-36, Subaru Select Monitor.></p> <p>Connector & terminal (B134) No. 3 (+) — Chassis ground (-):</p>	Does voltage change between 0 and 10 V?	Repair poor contact in ECM connector.	Go to step 2.
2	<p>CHECK GROUND SHORT CIRCUIT IN RADIATOR FAN RELAY 1 CONTROL CIRCUIT.</p> <p>1) Turn ignition switch to OFF. 2) Disconnect connectors from ECM. 3) Measure resistance of harness between ECM connector and chassis ground.</p> <p>Connector & terminal (B134) No. 3 — Chassis ground:</p>	Is the resistance less than 10 Ω?	Repair ground short circuit in radiator fan relay 1 control circuit.	Go to step 3.
3	<p>CHECK POWER SUPPLY FOR RELAY.</p> <p>1) Remove main fan relay from A/C relay holder. 2) Turn ignition switch to ON. 3) Measure voltage between fuse and relay box (F/B) connector and chassis ground.</p> <p>Connector & terminal (F66) No. 5 (+) — Chassis ground (-):</p>	Is the voltage more than 10 V?	Go to step 4.	Repair open circuit in harness between ignition switch and fuse and relay box (F/B) connector.
4	<p>CHECK MAIN FAN RELAY.</p> <p>1) Turn ignition switch to OFF. 2) Measure resistance between main fan relay terminals.</p> <p>Terminal No. 5 — No. 6:</p>	Is the resistance between 87 and 107 Ω?	Go to step 5.	Replace main fan relay.
5	<p>CHECK OPEN CIRCUIT IN MAIN FAN RELAY CONTROL CIRCUIT.</p> <p>Measure resistance of harness between ECM and main fan relay connector.</p> <p>Connector & terminal (B134) No. 3 — (F66) No. 6:</p>	Is the resistance less than 1 Ω?	Go to step 6.	Repair harness and connector. NOTE: In this case, repair the following: <ul style="list-style-type: none"> ● Open circuit in harness between ECM and main fan relay connector ● Poor contact in coupling connector
6	<p>CHECK POOR CONTACT.</p> <p>Check poor contact in ECM or main fan relay connector.</p>	Is there poor contact in ECM or main fan relay connector?	Repair poor contact in ECM or main fan relay connector.	Contact with SOA (distributor) service.

MEMO:

DIAGNOSTIC PROCEDURE WITH DIAGNOSTIC TROUBLE CODE (DTC)

Engine (Diagnostics)

BL: DTC P0692 — COOLING FAN RELAY 1 CIRCUIT HIGH INPUT — S078521K20

- **DTC DETECTING CONDITION:**
 - Two consecutive driving cycles with fault
- **TROUBLE SYMPTOM:**
 - Radiator fan does not operate properly.
 - Overheating

CAUTION:

After repair or replacement of faulty parts, conduct Clear Memory Mode <Ref. to EN-55, OPERATION, Clear Memory Mode.> and Inspection Mode <Ref. to EN-48, OPERATION, Inspection Mode.>.

DIAGNOSTIC PROCEDURE WITH DIAGNOSTIC TROUBLE CODE (DTC)

Engine (Diagnostics)

● WIRING DIAGRAM:

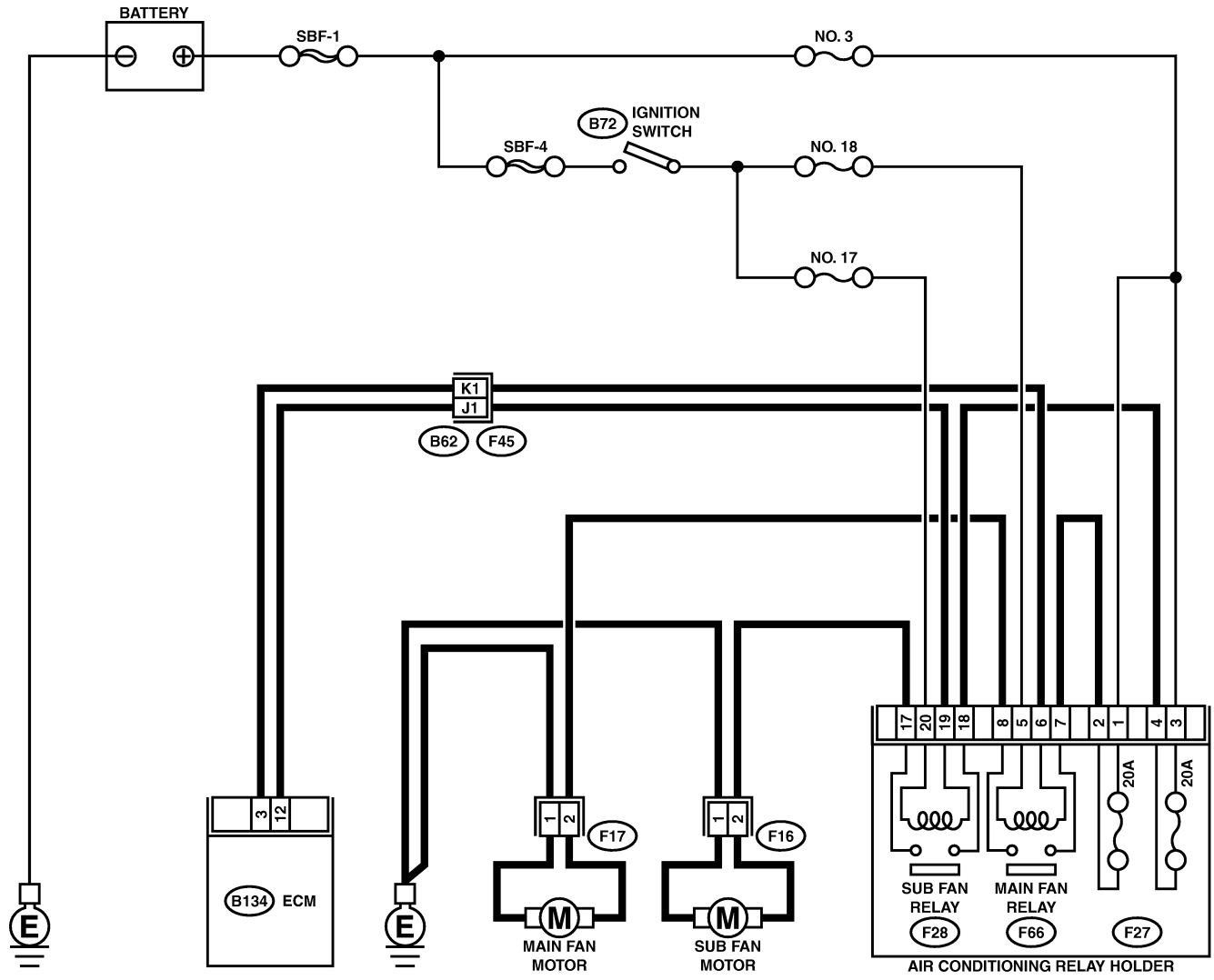

B72 (BLUE)



F27 F66

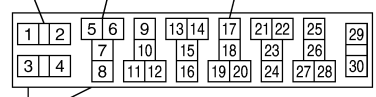

B134

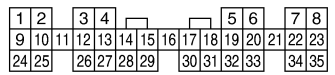

B62

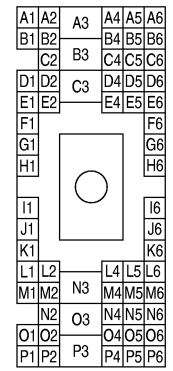

B2M3939

DIAGNOSTIC PROCEDURE WITH DIAGNOSTIC TROUBLE CODE (DTC)

Engine (Diagnostics)

No.	Step	Check	Yes	No
1	<p>CHECK OUTPUT SIGNAL FROM ECM.</p> <p>1) Turn ignition switch to OFF. 2) Connect test mode connector at the lower portion of instrument panel (on the driver's side), to the side of the center console box. 3) Turn ignition switch to ON. 4) While operating radiator fan relay, measure voltage between ECM and chassis ground.</p> <p>NOTE: Radiator fan relay operation can be executed using Subaru Select Monitor. For procedure, refer to "Compulsory Valve Operation Check Mode". <Ref. to EN-56, Compulsory Valve Operation Check Mode.></p> <p>Connector & terminal (B134) No. 3 (+) — Chassis ground (-):</p>	Does voltage change between 0 and 10 V?	Even if MIL lights up, the circuit has returned to a normal condition at this time. In this case, repair poor contact in ECM connector.	Go to step 2.
2	<p>CHECK SHORT CIRCUIT IN RADIATOR FAN RELAY CONTROL CIRCUIT.</p> <p>1) Turn ignition switch to OFF. 2) Remove main fan relay and sub fan relay. (with A/C models) 3) Disconnect test mode connector. 4) Turn ignition switch to ON. 5) Measure voltage between ECM and chassis ground.</p> <p>Connector & terminal (B134) No. 3 (+) — Chassis ground (-):</p>	Is the voltage more than 10 V?	Repair battery short circuit in radiator fan relay control circuit.	Go to step 3.
3	<p>CHECK MAIN FAN RELAY.</p> <p>1) Turn ignition switch to OFF. 2) Remove main fan relay. 3) Measure resistance between main fan relay terminals.</p> <p>Terminal No. 1 — No. 3:</p>	Is the resistance less than 1 Ω ?	Replace main fan relay.	Go to step 4.
4	<p>CHECK SUB FAN RELAY.</p> <p>1) Remove sub fan relay. 2) Measure resistance between sub fan relay terminals.</p> <p>Terminal No. 1 — No. 3</p>	Is the resistance less than 1 Ω ?	Replace sub fan relay.	Go to step 5.
5	<p>CHECK POOR CONTACT.</p> <p>Check poor contact in ECM connector.</p>	Is there poor contact in ECM connector?	Repair poor contact in ECM connector.	Replace ECM. <Ref. to FU-51, Engine Control Module.>

MEMO:

DIAGNOSTIC PROCEDURE WITH DIAGNOSTIC TROUBLE CODE (DTC)

Engine (Diagnostics)

BM: DTC P0703 — BRAKE SWITCH INPUT MALFUNCTION — S078521B64

● **DTC DETECTING CONDITION:**

- Two consecutive driving cycles with fault

CAUTION:

After repair or replacement of faulty parts, conduct Clear Memory Mode <Ref. to EN-55, OPERATION, Clear Memory Mode.> and Inspection Mode <Ref. to EN-48, OPERATION, Inspection Mode.>.

● **WIRING DIAGRAM:**

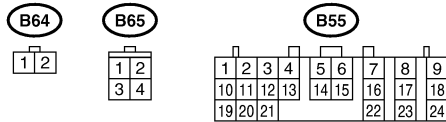
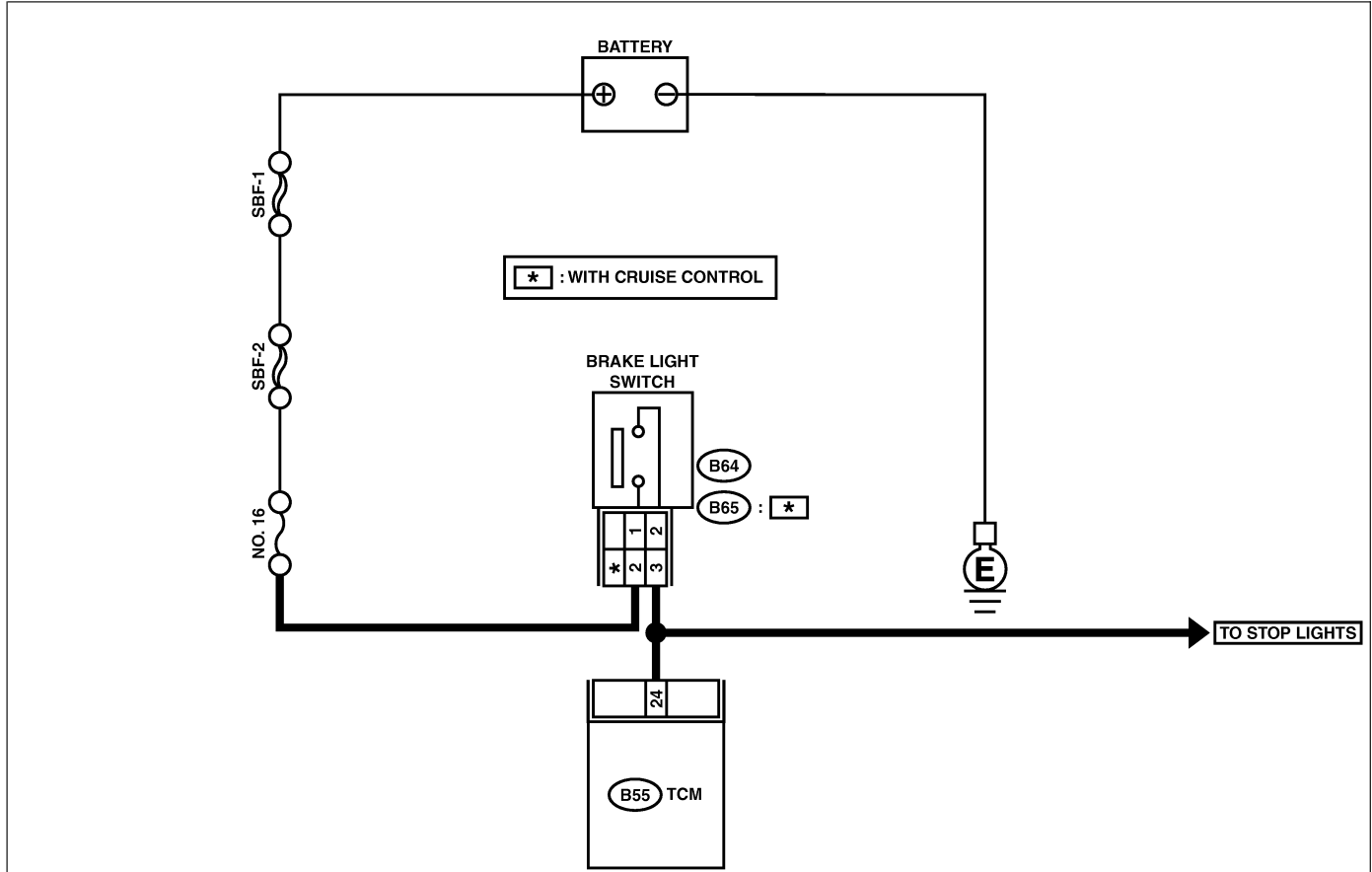

B2M3954

No.	Step	Check	Yes	No
1	CHECK OPERATION OF BRAKE LIGHT.	Does brake light come on when depressing the brake pedal?	Go to step 2.	Repair or replace brake light circuit.

DIAGNOSTIC PROCEDURE WITH DIAGNOSTIC TROUBLE CODE (DTC)

Engine (Diagnostics)

No.	Step	Check	Yes	No
2	<p>CHECK HARNESS BETWEEN TCM AND BRAKE LIGHT SWITCH CONNECTOR.</p> <p>1) Disconnect connectors from TCM and brake light switch.</p> <p>2) Measure resistance of harness between TCM and brake light switch connector.</p> <p>Connector & terminal (B55) No. 24 — (B64) No. 2: (B55) No. 24 — (B65) No. 3 (With cruise control):</p>	Is the resistance less than 1 Ω?	Go to step 3.	<p>Repair or replace harness and connector.</p> <p>NOTE: In this case, repair the following:</p> <ul style="list-style-type: none"> ● Open circuit in harness between TCM and brake light switch connector ● Poor contact in TCM connector ● Poor contact in brake light switch connector
3	<p>CHECK HARNESS BETWEEN TCM AND BRAKE LIGHT SWITCH CONNECTOR.</p> <p>Measure resistance of harness between TCM and chassis ground.</p> <p>Connector & terminal (B55) No. 24 — Chassis ground:</p>	Is the resistance more than 1 MΩ?	Go to step 4.	Repair ground short circuit in harness between TCM and brake light switch connector.
4	<p>CHECK INPUT SIGNAL FOR TCM.</p> <p>1) Connect connectors to TCM and brake light switch.</p> <p>2) Measure voltage between TCM and chassis ground.</p> <p>Connector & terminal (B55) No. 24 (+) — Chassis ground (-):</p>	Is the voltage less than 1 V when releasing the brake pedal?	Go to step 5.	Adjust or replace brake light switch. <Ref. to LI-7, STOP LIGHT SWITCH, INSPECTION, Stop Light System.>
5	<p>CHECK INPUT SIGNAL FOR TCM.</p> <p>Measure voltage between TCM and chassis ground.</p> <p>Connector & terminal (B55) No. 24 (+) — Chassis ground (-):</p>	Is the voltage more than 10 V when depressing the brake pedal?	Go to step 6.	Adjust or replace brake light switch. <Ref. to LI-7, STOP LIGHT SWITCH, INSPECTION, Stop Light System.>
6	<p>CHECK POOR CONTACT.</p> <p>Check poor contact in TCM connector.</p>	Is there poor contact in TCM connector?	Repair poor contact in TCM connector.	Replace TCM. <Ref. to AT-49, Transmission Control Module (TCM).>

DIAGNOSTIC PROCEDURE WITH DIAGNOSTIC TROUBLE CODE (DTC)

Engine (Diagnostics)

BN: DTC P0731 — GEAR 1 INCORRECT RATIO — S078521B70

NOTE:

For the diagnostic procedure, refer to DTC P0734. <Ref. to EN-273, DTC P0734 — GEAR 4 INCORRECT RATIO —, Diagnostic Procedure with Diagnostic Trouble Code (DTC).>

BO: DTC P0732 — GEAR 2 INCORRECT RATIO — S078521B71

NOTE:

For the diagnostic procedure, refer to DTC P0734. <Ref. to EN-273, DTC P0734 — GEAR 4 INCORRECT RATIO —, Diagnostic Procedure with Diagnostic Trouble Code (DTC).>

BP: DTC P0733 — GEAR 3 INCORRECT RATIO — S078521B72

NOTE:

For the diagnostic procedure, refer to DTC P0734. <Ref. to EN-273, DTC P0734 — GEAR 4 INCORRECT RATIO —, Diagnostic Procedure with Diagnostic Trouble Code (DTC).>

BQ: DTC P0734 — GEAR 4 INCORRECT RATIO — S078521B73

● **DTC DETECTING CONDITION:**

- Two consecutive driving cycles with fault

● **TROUBLE SYMPTOM:**

- Shift point too high or too low; engine brake not effected in “3” range; excessive shift shock; excessive tight corner “braking”

CAUTION:

After repair or replacement of faulty parts, conduct Clear Memory Mode <Ref. to EN-55, OPERATION, Clear Memory Mode.> and Inspection Mode <Ref. to EN-48, OPERATION, Inspection Mode.>.

● **WIRING DIAGRAM:**

No.	Step	Check	Yes	No
1	CHECK ANY OTHER DTC ON DISPLAY.	Is any other DTC displayed?	Inspect relevant DTC using “List of Diagnostic Trouble Code (DTC)”. <Ref. to EN-88, List of Diagnostic Trouble Code (DTC).>	Go to step 2.
2	CHECK THROTTLE POSITION SENSOR CIRCUIT. Check throttle position sensor circuit. <Ref. to AT-52, DTC 31 THROTTLE POSITION SENSOR, Diagnostic Procedure with Trouble Code (DTC).>	Is there any trouble in throttle position sensor circuit?	Repair or replace throttle position sensor circuit.	Go to step 3.
3	CHECK FRONT VEHICLE SPEED SENSOR CIRCUIT. Check front vehicle speed sensor circuit. <Ref. to AT-60, DTC 33 FRONT VEHICLE SPEED SENSOR, Diagnostic Procedure with Trouble Code (DTC).>	Is there any trouble in vehicle speed sensor 2 circuit?	Repair or replace vehicle speed sensor 2 circuit.	Go to step 4.
4	CHECK TORQUE CONVERTER TURBINE SPEED SENSOR CIRCUIT. Check torque converter turbine speed sensor circuit. <Ref. to AT-66, DTC 36 TORQUE CONVERTER TURBINE SPEED SENSOR, Diagnostic Procedure with Trouble Code (DTC).>	Is there any trouble in torque converter turbine speed sensor circuit?	Repair or replace torque converter turbine speed sensor circuit.	Go to step 5.
5	CHECK POOR CONTACT. Check poor contact in TCM connector.	Is there poor contact in TCM connector?	Repair poor contact in TCM connector.	Go to step 6.
6	CHECK MECHANICAL TROUBLE. Check mechanical trouble in automatic transmission.	Is there any mechanical trouble in automatic transmission?	Repair or replace automatic transmission. <Ref. to AT-12, INSPECTION, Road Test.>	Replace TCM. <Ref. to AT-49, Transmission Control Module (TCM).>

DIAGNOSTIC PROCEDURE WITH DIAGNOSTIC TROUBLE CODE (DTC)

Engine (Diagnostics)

BR: DTC P0741 — TORQUE CONVERTER CLUTCH SYSTEM MALFUNCTION

S078521G04

● DTC DETECTING CONDITION:

- Two consecutive driving cycles with fault

● TROUBLE SYMPTOM:

- No lock-up (after engine warm-up)
- No shift or excessive tight corner “braking”

CAUTION:

After repair or replacement of faulty parts, conduct Clear Memory Mode <Ref. to EN-55, OPERATION, Clear Memory Mode.> and Inspection Mode <Ref. to EN-48, OPERATION, Inspection Mode.>.

No.	Step	Check	Yes	No
1	CHECK ANY OTHER DTC ON DISPLAY.	Is any other DTC displayed?	Inspect the relevant DTC using “List of Diagnostic Trouble Code (DTC)”. <Ref. to EN-88, List of Diagnostic Trouble Code (DTC).>	Go to step 2.
2	CHECK LOCK-UP DUTY SOLENOID CIRCUIT. Check lock-up duty solenoid circuit. <Ref. to AT-100, DTC 77 LOCK-UP DUTY SOLENOID, Diagnostic Procedure with Trouble Code (DTC).>	Is there any trouble in lock-up duty solenoid circuit?	Repair or replace lock-up duty solenoid circuit.	Go to step 3.
3	CHECK THROTTLE POSITION SENSOR CIRCUIT. Check throttle position sensor circuit. <Ref. to AT-52, DTC 31 THROTTLE POSITION SENSOR, Diagnostic Procedure with Trouble Code (DTC).>	Is there any trouble in throttle position sensor circuit?	Repair or replace throttle position sensor circuit.	Go to step 4.
4	CHECK TORQUE CONVERTER TURBINE SPEED SENSOR CIRCUIT. Check torque converter turbine speed sensor circuit. <Ref. to AT-66, DTC 36 TORQUE CONVERTER TURBINE SPEED SENSOR, Diagnostic Procedure with Trouble Code (DTC).>	Is there any trouble in torque converter turbine speed sensor circuit?	Repair or replace torque converter turbine speed sensor circuit.	Go to step 5.
5	CHECK ENGINE SPEED INPUT CIRCUIT. Check engine speed input circuit. <Ref. to AT-44, DTC 11 ENGINE SPEED SIGNAL, Diagnostic Procedure with Trouble Code (DTC).>	Is there any trouble in engine speed input circuit?	Repair or replace engine speed input circuit.	Go to step 6.
6	CHECK INHIBITOR SWITCH CIRCUIT. Check inhibitor switch circuit. <Ref. to AT-122, CHECK INHIBITOR SWITCH., Diagnostic Procedure for No-diagnostic Trouble Code (DTC).>	Is there any trouble in inhibitor switch circuit?	Repair or replace inhibitor switch circuit.	Go to step 7.
7	CHECK BRAKE LIGHT SWITCH CIRCUIT. Check brake light switch circuit. <Ref. to AT-120, CHECK BRAKE SWITCH., Diagnostic Procedure for No-diagnostic Trouble Code (DTC).>	Is there any trouble in brake light switch circuit?	Repair or replace brake light switch circuit.	Go to step 8.

DIAGNOSTIC PROCEDURE WITH DIAGNOSTIC TROUBLE CODE (DTC)

Engine (Diagnostics)

No.	Step	Check	Yes	No
8	CHECK ATF TEMPERATURE SENSOR CIRCUIT. Check ATF temperature sensor circuit. <Ref. to AT-48, DTC 27 ATF TEMPERATURE SENSOR, Diagnostic Procedure with Trouble Code (DTC).>	Is there any trouble in ATF temperature sensor circuit?	Repair or replace ATF temperature sensor circuit.	Go to step 9.
9	CHECK POOR CONTACT. Check poor contact in TCM connector.	Is there poor contact in TCM connector?	Repair poor contact in TCM connector.	Go to step 10.
10	CHECK MECHANICAL TROUBLE. Check mechanical trouble in automatic transmission.	Is there any mechanical trouble in automatic transmission?	Repair or replace automatic transmission. <Ref. to AT-12, INSPECTION, Road Test.>	Replace TCM. <Ref. to AT-49, Transmission Control Module (TCM).>

DIAGNOSTIC PROCEDURE WITH DIAGNOSTIC TROUBLE CODE (DTC)

Engine (Diagnostics)

BS: DTC P0851 — NEUTRAL POSITION SWITCH CIRCUIT LOW INPUT (AT MODEL) — S078521K43

- **DTC DETECTING CONDITION:**
 - Two consecutive driving cycles with fault
- **TROUBLE SYMPTOM:**
 - Erroneous idling

CAUTION:

After repair or replacement of faulty parts, conduct Clear Memory Mode <Ref. to EN-55, OPERATION, Clear Memory Mode.> and Inspection Mode <Ref. to EN-48, OPERATION, Inspection Mode.>.

- **WIRING DIAGRAM:**

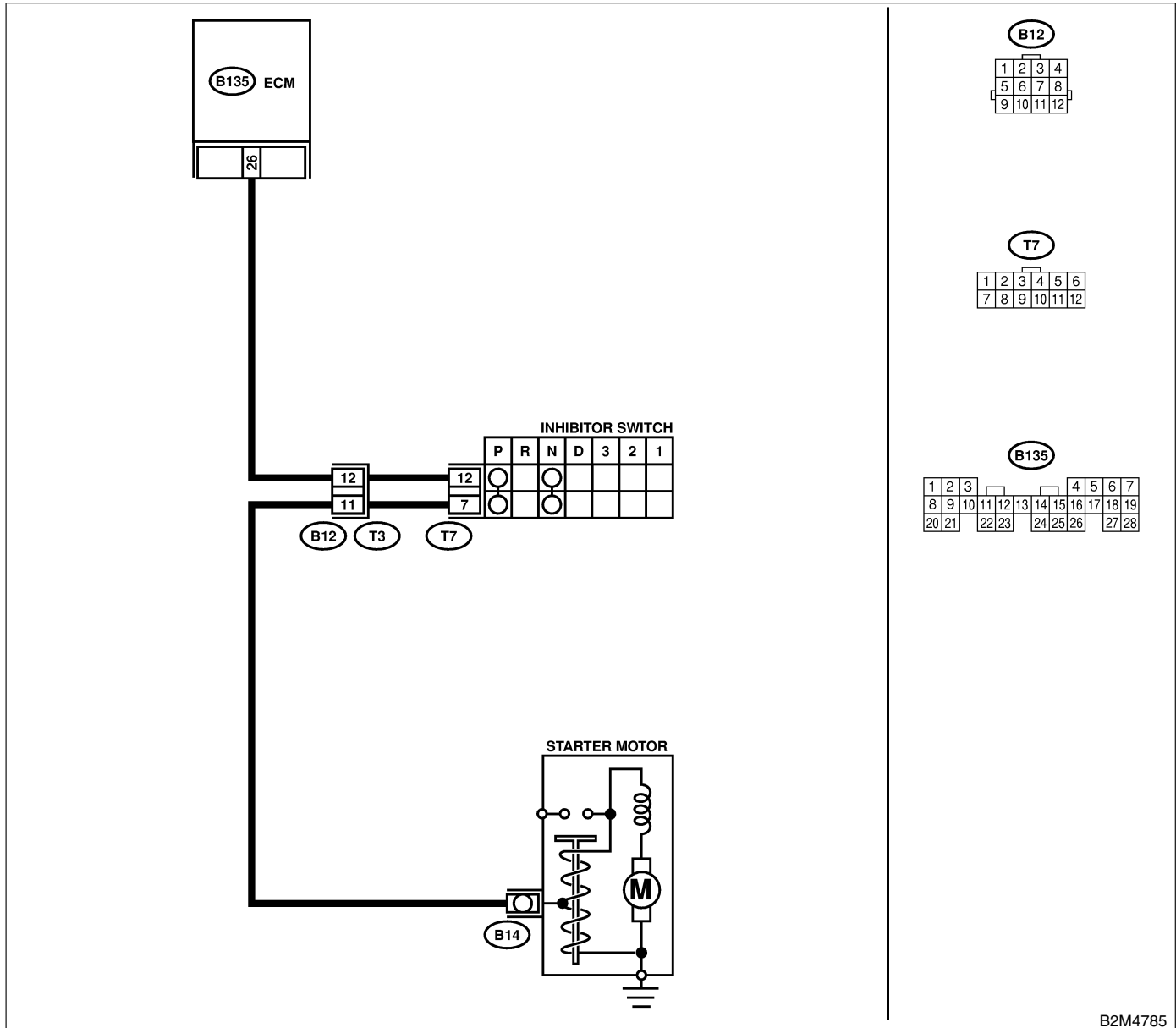

DIAGNOSTIC PROCEDURE WITH DIAGNOSTIC TROUBLE CODE (DTC)

Engine (Diagnostics)

No.	Step	Check	Yes	No
1	CHECK ANY OTHER DTC ON DISPLAY.	Is any other DTC displayed?	Inspect the relevant DTC using "List of Diagnostics Trouble Code (DTC)". <Ref. to EN-88, List of Diagnostic Trouble Code (DTC).>	Go to step 2.
2	CHECK INPUT SIGNAL FOR ECM. 1) Turn ignition switch to ON. 2) Measure voltage between ECM and chassis ground. Connector & terminal (B135) No. 26 (+) — Chassis ground (-):	Is the voltage between 4.5 and 5.5 V at except "N" and "P" positions?	Even if MIL lights up, the circuit has returned to a normal condition at this time.	Go to step 3.
3	CHECK HARNESS BETWEEN ECM AND TRANSMISSION HARNESS CONNECTOR. 1) Turn ignition switch to OFF. 2) Disconnect connectors from ECM and transmission harness connector (T3). 3) Measure resistance of harness between ECM connector and chassis ground. Connector & terminal (B135) No. 26 — Chassis ground:	Is the resistance less than 10 Ω?	Repair ground short circuit in harness between ECM and transmission harness connector.	Go to step 4.
4	CHECK TRANSMISSION HARNESS CONNECTOR. 1) Disconnect connector from inhibitor switch. 2) Measure resistance of harness between transmission harness connector and engine ground. Connector & terminal (T3) No. 12 — Engine ground:	Is the resistance less than 10 Ω?	Repair ground short circuit in harness between transmission harness and inhibitor switch connector.	Go to step 5.
5	CHECK INHIBITOR SWITCH. Measure resistance between inhibitor switch connector receptacle's terminals in select lever except for "N" position. Terminals No. 7 — No. 12:	Is the resistance more than 1 MΩ at except "N" and "P" positions?	Go to step 6.	Replace inhibitor switch. <Ref. to AT-29, Inhibitor switch.>
6	CHECK SELECTOR CABLE CONNECTION.	Is there any fault in selector cable connection to inhibitor switch?	Repair selector cable connection. <Ref. to CS-26, Select Cable.>	Contact with SOA (distributor) service. NOTE: Inspection by DTM is required, because probable cause is deterioration of multiple parts.

DIAGNOSTIC PROCEDURE WITH DIAGNOSTIC TROUBLE CODE (DTC)

Engine (Diagnostics)

BT: DTC P0851 — NEUTRAL POSITION SWITCH CIRCUIT LOW INPUT (MT MODEL) — S078521K44

- **DTC DETECTING CONDITION:**
 - Two consecutive driving cycles with fault
- **TROUBLE SYMPTOM:**
 - Erroneous idling

CAUTION:

After repair or replacement of faulty parts, conduct Clear Memory Mode <Ref. to EN-55, OPERATION, Clear Memory Mode.> and Inspection Mode <Ref. to EN-48, OPERATION, Inspection Mode.>.

● WIRING DIAGRAM:

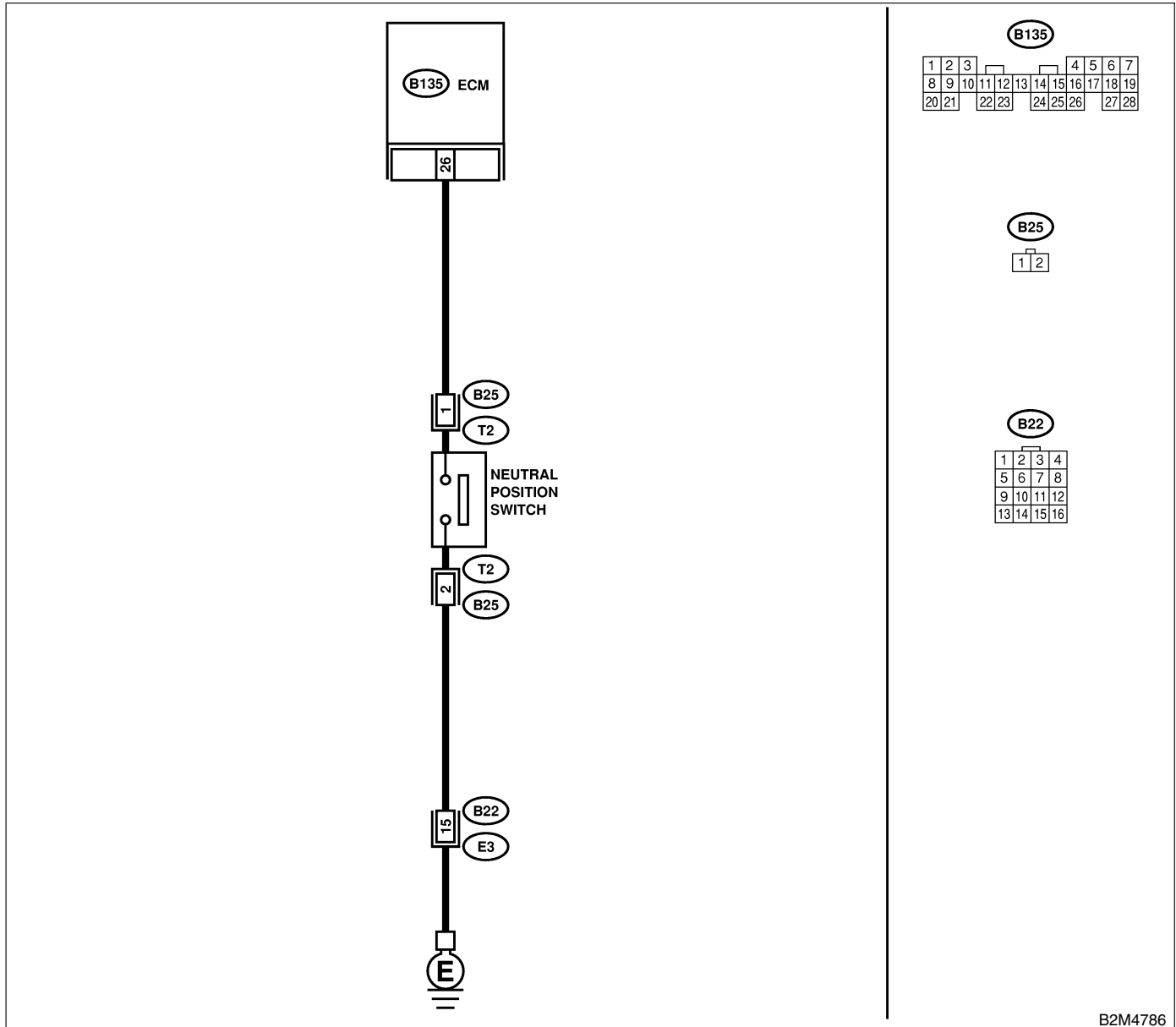

B2M4786

DIAGNOSTIC PROCEDURE WITH DIAGNOSTIC TROUBLE CODE (DTC)

Engine (Diagnostics)

No.	Step	Check	Yes	No
1	CHECK INPUT SIGNAL FOR ECM. 1) Turn ignition switch to ON. 2) Measure voltage between ECM and chassis ground. <i>Connector & terminal</i> <i>(B135) No. 26 (+) — Chassis ground (-):</i>	Is the voltage more than 10 V in neutral position?	Go to step 2.	Go to step 4.
2	CHECK INPUT SIGNAL FOR ECM. Measure voltage between ECM and chassis ground. <i>Connector & terminal</i> <i>(B135) No. 26 (+) — Chassis ground (-):</i>	Is the voltage less than 1 V in other positions?	Go to step 3.	Go to step 4.
3	CHECK POOR CONTACT. Check poor contact in ECM connector.	Is there poor contact in ECM connector?	Repair poor contact in ECM connector.	Contact with SOA (distributor) service. NOTE: Inspection by DTM is required, because probable cause is deterioration of multiple parts.
4	CHECK NEUTRAL POSITION SWITCH. 1) Turn ignition switch to OFF. 2) Disconnect connector from transmission harness. 3) Measure resistance between transmission harness and connector terminals. <i>Connector & terminal</i> <i>(T2) No. 1 — No. 2:</i>	Is the resistance more than 1 M Ω in neutral position?	Go to step 5.	Repair short circuit in transmission harness or replace neutral position switch.
5	CHECK HARNESS BETWEEN ECM AND NEUTRAL POSITION SWITCH CONNECTOR. Measure resistance between ECM and chassis ground. <i>Connector & terminal</i> <i>(B135) No. 26 — Chassis ground:</i>	Is the resistance less than 10 Ω ?	Repair ground short circuit in harness between ECM and transmission harness connector.	Go to step 6.
6	CHECK POOR CONTACT. Check poor contact in transmission harness connector.	Is there poor contact in transmission harness connector?	Repair poor contact in transmission harness connector.	Contact with SOA (distributor) service. NOTE: Inspection by DTM is required, because probable cause is deterioration of multiple parts.

DIAGNOSTIC PROCEDURE WITH DIAGNOSTIC TROUBLE CODE (DTC)

Engine (Diagnostics)

BU: DTC P0852 — NEUTRAL POSITION SWITCH CIRCUIT HIGH INPUT (AT MODEL) — S078521K45

- **DTC DETECTING CONDITION:**
 - Two consecutive driving cycles with fault
- **TROUBLE SYMPTOM:**
 - Erroneous idling

CAUTION:

After repair or replacement of faulty parts, conduct Clear Memory Mode <Ref. to EN-55, OPERATION, Clear Memory Mode.> and Inspection Mode <Ref. to EN-48, OPERATION, Inspection Mode.>.

● WIRING DIAGRAM:

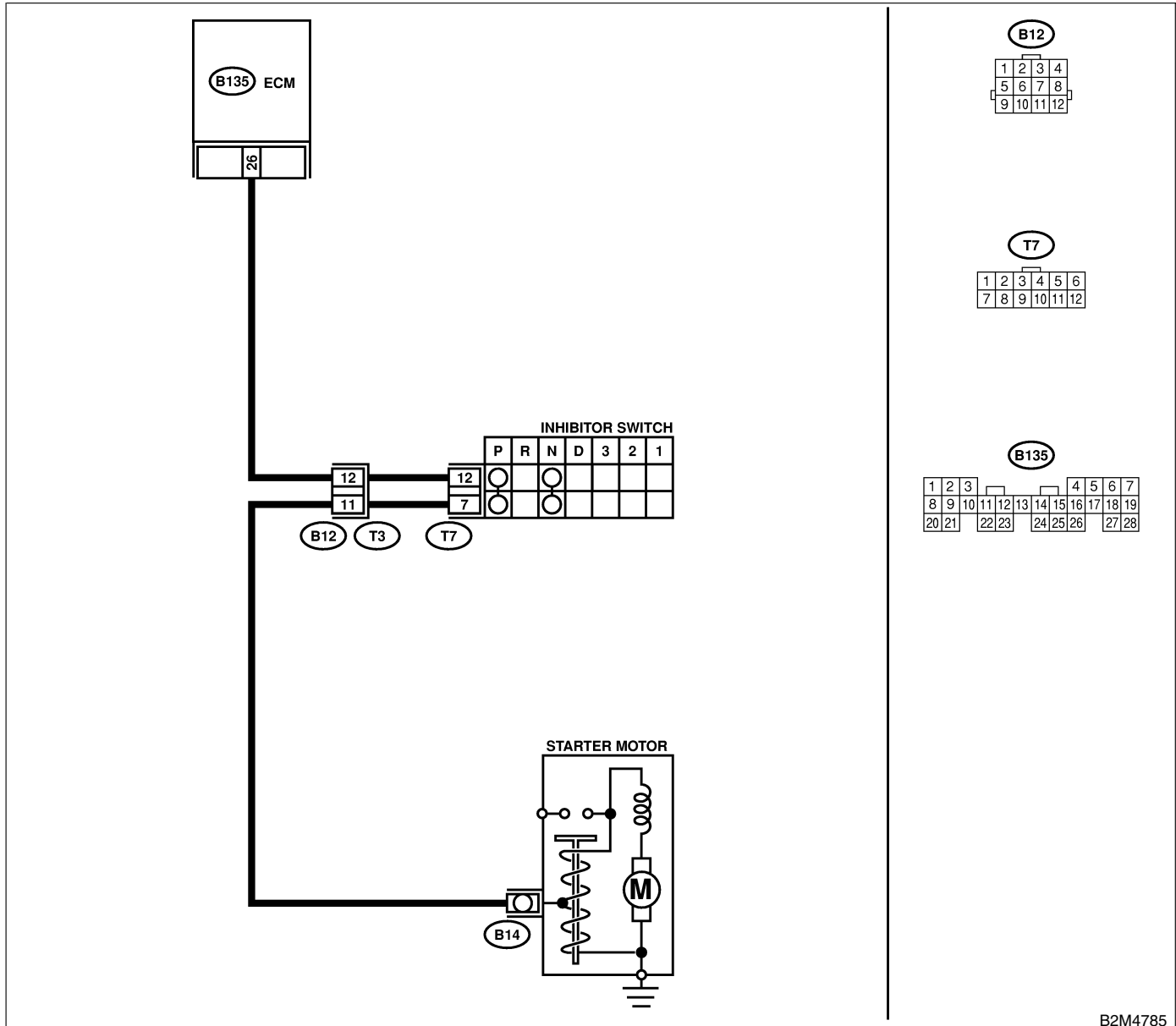

B2M4785

DIAGNOSTIC PROCEDURE WITH DIAGNOSTIC TROUBLE CODE (DTC)

Engine (Diagnostics)

No.	Step	Check	Yes	No
1	CHECK ANY OTHER DTC ON DISPLAY.	Is any other DTC displayed?	Inspect the relevant DTC using "List of Diagnostics Trouble Code (DTC)". <Ref. to EN-88, List of Diagnostic Trouble Code (DTC).	Go to step 2.
2	CHECK INPUT SIGNAL FOR ECM. 1) Turn ignition switch to ON. 2) Measure voltage between ECM and chassis ground in select lever "N" and "P" positions. Connector & terminal (B135) No. 26 (+) — Chassis ground (-):	Is the voltage less than 1 V?	Go to step 3.	Go to step 5.
3	CHECK INPUT SIGNAL FOR ECM. Measure voltage between ECM and chassis ground in select lever except for "N" and "P" positions. Connector & terminal (B135) No. 26 (+) — Chassis ground (-):	Is the voltage between 4.5 and 5.5 V?	Go to step 4.	Go to step 5.
4	CHECK POOR CONTACT. Check poor contact in ECM connector.	Is there poor contact in ECM connector?	Repair poor contact in ECM connector.	Contact with SOA (distributor) service. NOTE: Inspection by DTM is required, because probable cause is deterioration of multiple parts.
5	CHECK INPUT SIGNAL FOR ECM. Measure voltage between ECM and chassis ground. Connector & terminal (B135) No. 26 (+) — Chassis ground (-):	Is the voltage more than 10 V?	Repair battery short circuit in harness between ECM and inhibitor switch connector.	Go to step 6.
6	CHECK HARNESS BETWEEN ECM AND INHIBITOR SWITCH CONNECTOR. 1) Turn ignition switch to OFF. 2) Disconnect connectors from ECM and inhibitor switch. 3) Measure resistance of harness between ECM and inhibitor switch connector. Connector & terminal (B135) No. 26 — (T7) No. 12:	Is the resistance less than 1 Ω?	Go to step 7.	Repair harness and connector. NOTE: In this case, repair the following: ● Open circuit in harness between ECM and inhibitor switch connector ● Poor contact in coupling connector ● Poor contact in inhibitor switch connector ● Poor contact in ECM connector

DIAGNOSTIC PROCEDURE WITH DIAGNOSTIC TROUBLE CODE (DTC)

Engine (Diagnostics)

No.	Step	Check	Yes	No
7	<p>CHECK INHIBITOR SWITCH GROUND LINE. Measure resistance of harness between inhibitor switch connector and engine ground. Connector & terminal <i>(T7) No. 7 — Engine ground:</i></p>	Is the resistance less than 5 Ω ?	Go to step 8.	Repair open circuit in harness between inhibitor switch connector and starter motor ground line. NOTE: In this case, repair the following: <ul style="list-style-type: none"> ● Open circuit in harness between inhibitor switch connector and starter motor ground line ● Poor contact in starter motor connector ● Poor contact in starter motor ground ● Starter motor
8	<p>CHECK INHIBITOR SWITCH. Measure resistance between inhibitor switch connector receptacle's terminals in select lever "N" and "P" positions. Terminals <i>No. 7 — No. 12:</i></p>	Is the resistance less than 1 Ω ?	Go to step 9.	Replace inhibitor switch. <Ref. to AT-29, Inhibitor Switch.>
9	<p>CHECK SELECTOR CABLE CONNECTION.</p>	Is there any fault in selector cable connection to inhibitor switch?	Repair selector cable connection. <Ref. to CS-26, Select Cable.>	Contact with SOA (distributor) service. NOTE: Inspection by DTM is required, because probable cause is deterioration of multiple parts.

MEMO:

DIAGNOSTIC PROCEDURE WITH DIAGNOSTIC TROUBLE CODE (DTC)

Engine (Diagnostics)

BV: DTC P0852 — NEUTRAL POSITION SWITCH CIRCUIT HIGH INPUT (MT MODEL) — S078521K46

- **DTC DETECTING CONDITION:**
 - Two consecutive driving cycles with fault
- **TROUBLE SYMPTOM:**
 - Erroneous idling

CAUTION:

After repair or replacement of faulty parts, conduct Clear Memory Mode <Ref. to EN-55, OPERATION, Clear Memory Mode.> and Inspection Mode <Ref. to EN-48, OPERATION, Inspection Mode.>.

● WIRING DIAGRAM:

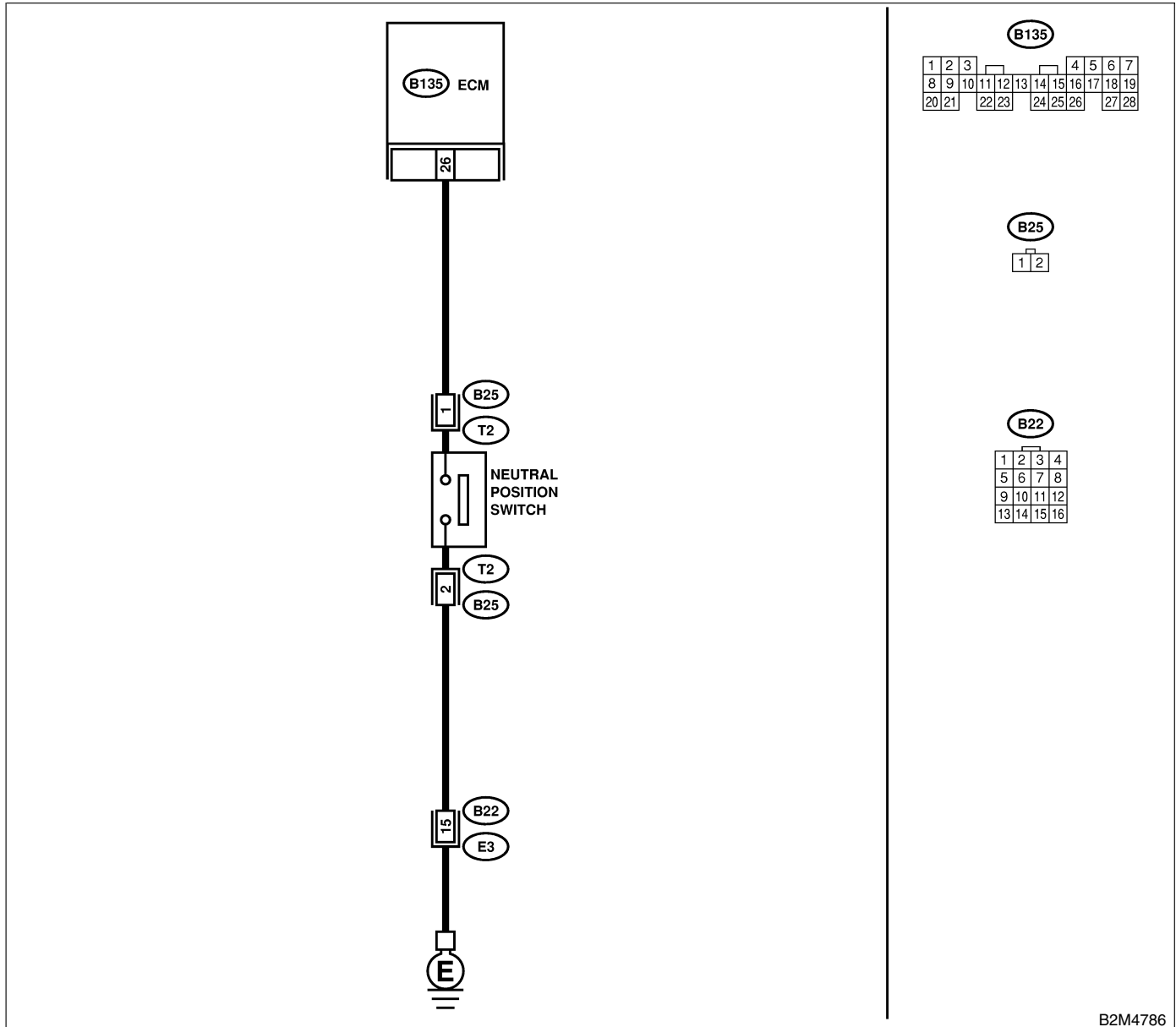

B2M4786

DIAGNOSTIC PROCEDURE WITH DIAGNOSTIC TROUBLE CODE (DTC)

Engine (Diagnostics)

No.	Step	Check	Yes	No
1	CHECK INPUT SIGNAL FOR ECM. 1) Turn ignition switch to ON. 2) Measure voltage between ECM and chassis ground. <i>Connector & terminal</i> <i>(B135) No. 26 (+) — Chassis ground (-):</i>	Is the voltage more than 10 V in neutral position?	Go to step 2.	Go to step 4.
2	CHECK INPUT SIGNAL FOR ECM. Measure voltage between ECM and chassis ground. <i>Connector & terminal</i> <i>(B135) No. 26 (+) — Chassis ground (-):</i>	Is the voltage less than 1 V in other positions?	Go to step 3.	Go to step 5.
3	CHECK POOR CONTACT. Check poor contact in ECM connector.	Is there poor contact in ECM connector?	Repair poor contact in ECM connector.	Contact with SOA (distributor) service. NOTE: Inspection by DTM is required, because probable cause is deterioration of multiple parts.
4	CHECK NEUTRAL POSITION SWITCH. Measure resistance between transmission harness connector terminals. <i>Connector & terminal</i> <i>(T2) No. 1 — No. 2:</i>	Is the resistance less than 1 Ω in other positions?	Go to step 5.	Repair open circuit in transmission harness or replace neutral position switch.
5	CHECK HARNESS BETWEEN ECM AND NEUTRAL POSITION SWITCH CONNECTOR. 1) Disconnect connector from ECM. 2) Measure resistance of harness between ECM and transmission harness connector. <i>Connector & terminal</i> <i>(B135) No. 26 — (B25) No. 1:</i>	Is the resistance less than 1 Ω ?	Go to step 6.	Repair open circuit in harness between ECM and transmission harness connector.
6	CHECK HARNESS BETWEEN ECM AND NEUTRAL POSITION SWITCH CONNECTOR. Measure resistance of harness between transmission harness connector and engine ground. <i>Connector & terminal</i> <i>(B25) No. 2 — Engine ground:</i>	Is the resistance less than 5 Ω ?	Go to step 7.	Repair harness and connector. NOTE: In this case, repair the following: <ul style="list-style-type: none"> ● Open circuit in harness between transmission harness connector and engine grounding terminal ● Poor contact in coupling connector

DIAGNOSTIC PROCEDURE WITH DIAGNOSTIC TROUBLE CODE (DTC)

Engine (Diagnostics)

No.	Step	Check	Yes	No
7	CHECK POOR CONTACT. Check poor contact in transmission harness connector.	Is there poor contact in transmission harness connector?	Repair poor contact in transmission harness connector.	Contact with SOA (distributor) service. NOTE: Inspection by DTM is required, because probable cause is deterioration of multiple parts.

MEMO:

DIAGNOSTIC PROCEDURE WITH DIAGNOSTIC TROUBLE CODE (DTC)

Engine (Diagnostics)

BW: DTC P0864 — AUTOMATIC TRANSMISSION DIAGNOSIS INPUT SIGNAL CIRCUIT MALFUNCTION — S078521K10

● **DTC DETECTING CONDITION:**

- Two consecutive driving cycles with fault

CAUTION:

After repair or replacement of faulty parts, conduct Clear Memory Mode <Ref. to EN-55, OPERATION, Clear Memory Mode.> and Inspection Mode <Ref. to EN-48, OPERATION, Inspection Mode.>.

● **WIRING DIAGRAM:**

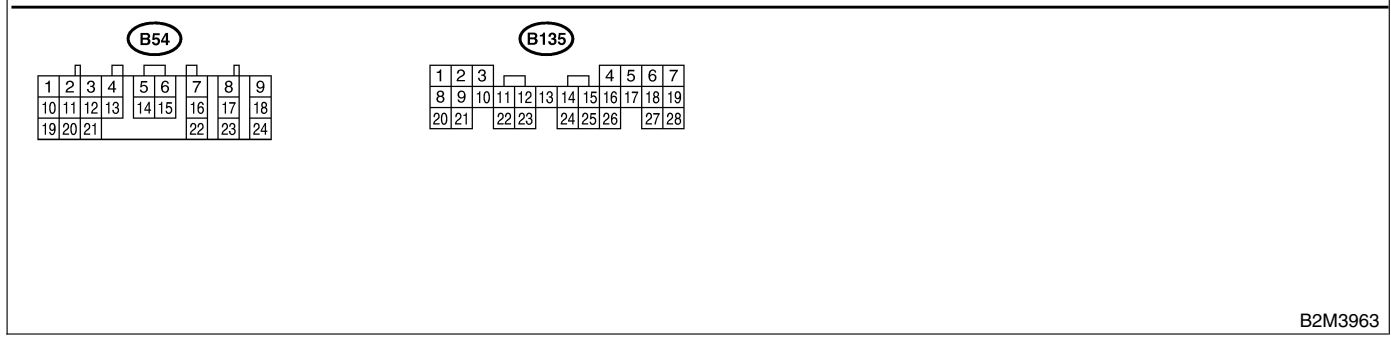
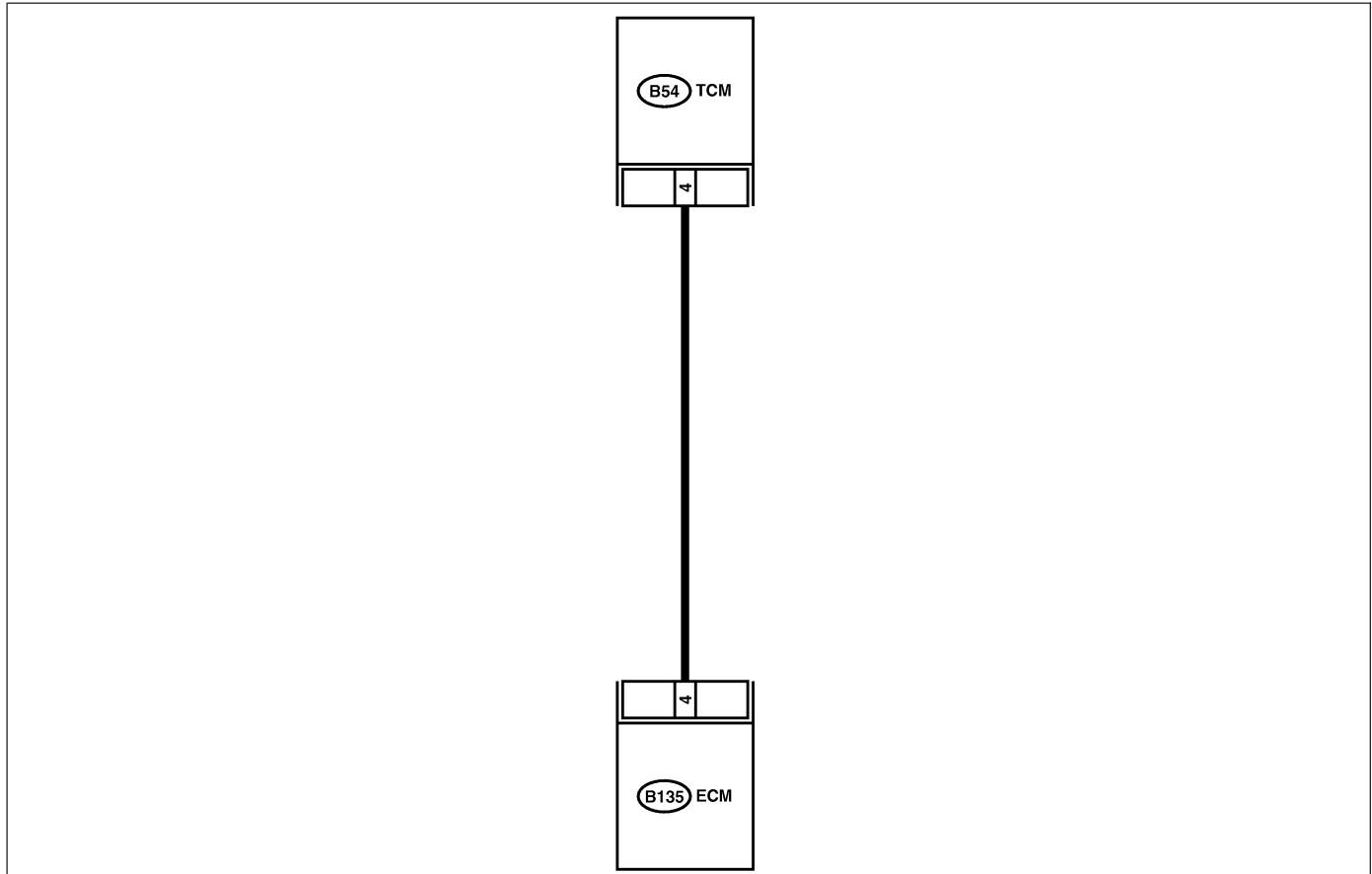

B2M3963

No.	Step	Check	Yes	No
1	CHECK DRIVING CONDITION. 1) Start and warm-up the engine until the radiator fan makes one complete rotation. 2) Drive the vehicle.	Is AT shift control functioning properly?	Go to step 2.	Replace TCM. <Ref. to AT-49, Transmission Control Module (TCM).>

DIAGNOSTIC PROCEDURE WITH DIAGNOSTIC TROUBLE CODE (DTC)

Engine (Diagnostics)

No.	Step	Check	Yes	No
2	CHECK ACCESSORY.	Are car phone and/or CB installed on vehicle?	Repair grounding line of car phone or CB system.	Replace TCM. <Ref. to AT-49, Transmission Control Module (TCM).>

DIAGNOSTIC PROCEDURE WITH DIAGNOSTIC TROUBLE CODE (DTC)

Engine (Diagnostics)

BX: DTC P0865 — AUTOMATIC TRANSMISSION DIAGNOSIS INPUT SIGNAL CIRCUIT LOW INPUT — S078521K11

● DTC DETECTING CONDITION:

- Two consecutive driving cycles with fault

CAUTION:

After repair or replacement of faulty parts, conduct Clear Memory Mode <Ref. to EN-55, OPERATION, Clear Memory Mode.> and Inspection Mode <Ref. to EN-48, OPERATION, Inspection Mode.>.

● WIRING DIAGRAM:

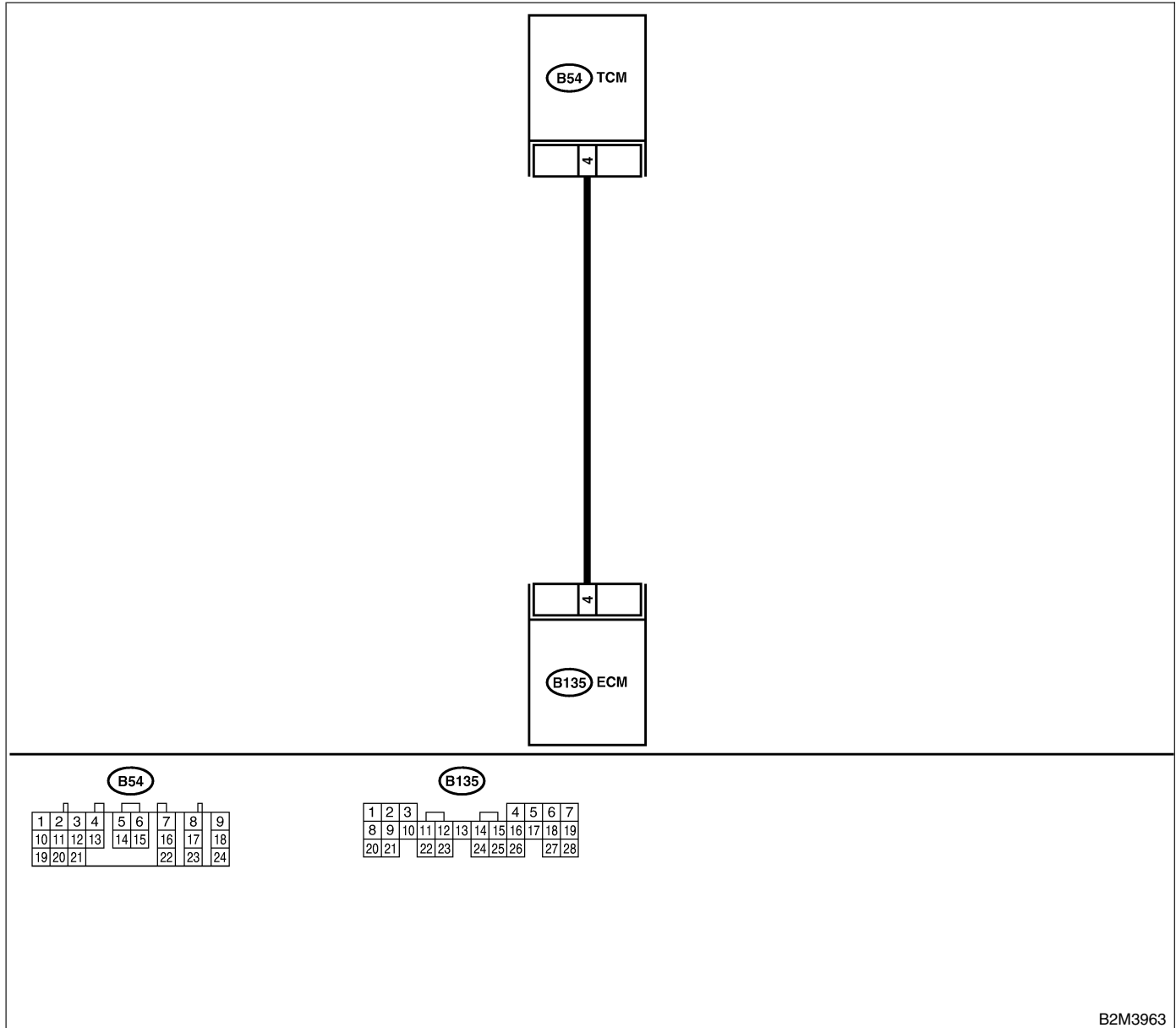

B2M3963

DIAGNOSTIC PROCEDURE WITH DIAGNOSTIC TROUBLE CODE (DTC)

Engine (Diagnostics)

No.	Step	Check	Yes	No
1	CHECK HARNESS BETWEEN ECM AND TCM CONNECTOR. 1) Turn ignition switch to ON. 2) Measure voltage between ECM and chassis ground. Connector & terminal (B135) No. 4 (+) — Chassis ground (-):	Is the voltage less than 1 V?	Go to step 2.	Even if MIL lights up, the circuit has returned to a normal condition at this time. NOTE: In this case, repair the following: ● Poor contact in ECM connector ● Poor contact in TCM connector
2	CHECK HARNESS BETWEEN ECM AND TCM CONNECTOR. 1) Turn ignition switch to OFF. 2) Disconnect connector from ECM and TCM. 3) Measure resistance of harness between ECM and chassis ground. Connector & terminal (B135) No. 4 — Chassis ground:	Is the resistance less than 10 Ω?	Repair ground short circuit in harness between ECM and TCM connector.	Go to step 3.
3	CHECK OUTPUT SIGNAL FOR ECM. 1) Connect connector to ECM. 2) Turn ignition switch to ON. 3) Measure voltage between ECM and chassis ground. Connector & terminal (B135) No. 4 (+) — Chassis ground (-):	Is the voltage more than 5 V?	Go to step 4.	Repair poor contact in ECM connector.
4	CHECK TROUBLE CODE FOR AUTOMATIC TRANSMISSION. Read trouble code for automatic transmission. <Ref. to AT-25, Read Diagnostic Trouble Code (DTC).>	Does trouble code appear for automatic transmission?	Inspect trouble code for automatic transmission. <Ref. to AT-44, Diagnostic Procedure with Diagnostic Trouble Code (DTC).>	Replace TCM. <Ref. to AT-49, Transmission Control Module (TCM).>

DIAGNOSTIC PROCEDURE WITH DIAGNOSTIC TROUBLE CODE (DTC)

Engine (Diagnostics)

BY: DTC P0866 — AUTOMATIC TRANSMISSION DIAGNOSIS INPUT SIGNAL CIRCUIT HIGH INPUT — S078521K12

● DTC DETECTING CONDITION:

- Two consecutive driving cycles with fault

CAUTION:

After repair or replacement of faulty parts, conduct Clear Memory Mode <Ref. to EN-55, OPERATION, Clear Memory Mode.> and Inspection Mode <Ref. to EN-48, OPERATION, Inspection Mode.>.

● WIRING DIAGRAM:

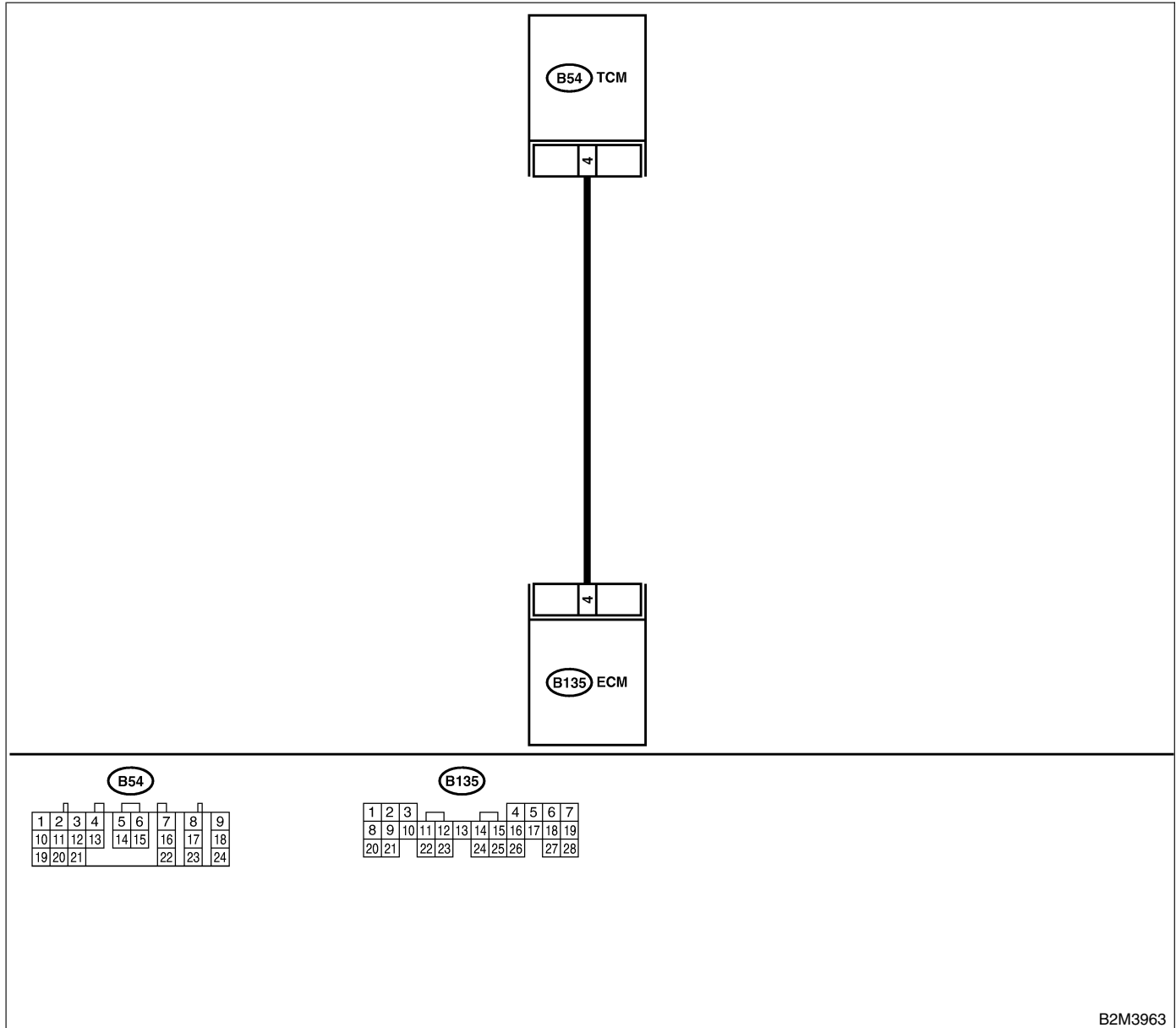

B2M3963

DIAGNOSTIC PROCEDURE WITH DIAGNOSTIC TROUBLE CODE (DTC)

Engine (Diagnostics)

No.	Step	Check	Yes	No
1	CHECK HARNESS BETWEEN ECM AND TCM CONNECTOR. 1) Turn ignition switch to ON. 2) Measure voltage between ECM and chassis ground. <i>Connector & terminal</i> <i>(B135) No. 4 (+) — Chassis ground (-):</i>	Is the voltage more than 10 V?	Repair battery short circuit in harness between ECM and TCM connector. After repair, replace ECM. <Ref. to FU-51, Control Module.>	Go to step 2.
2	CHECK HARNESS BETWEEN ECM AND TCM CONNECTOR. Measure voltage between ECM connector and chassis ground. <i>Connector & terminal</i> <i>(B135) No. 4 (+) — Chassis ground (-):</i>	Is the voltage more than 4 V?	Go to step 5.	Go to step 3.
3	CHECK HARNESS BETWEEN ECM AND TCM CONNECTOR. Measure voltage between ECM connector and chassis ground. <i>Connector & terminal</i> <i>(B135) No. 4 (+) — Chassis ground (-):</i>	Is the voltage less than 1 V?	Repair poor contact in ECM connector.	Go to step 4.
4	CHECK OUTPUT SIGNAL FROM ECM. Measure voltage between ECM and chassis ground. <i>Connector & terminal</i> <i>(B135) No. 4 (+) — Chassis ground (-):</i>	Does the voltage change from 1 V to 4 V while monitoring the value with voltage meter?	Even if MIL lights up, the circuit has returned to a normal condition at this time. NOTE: In this case, repair the following: <ul style="list-style-type: none"> ● Poor contact in ECM connector ● Poor contact in TCM connector 	Contact with SOA (distributor) service. NOTE: Inspection by DTM is required, because probable cause is deterioration of multiple parts.
5	CHECK HARNESS BETWEEN ECM AND TCM CONNECTOR. Measure voltage between TCM and chassis ground. <i>Connector & terminal</i> <i>(B54) No. 4 (+) — Chassis ground (-):</i>	Is the voltage more than 4 V?	Go to step 6.	Repair open circuit in harness between ECM and TCM connector.
6	CHECK POOR CONTACT. Check poor contact in TCM connector.	Is there poor contact in TCM connector?	Repair poor contact in TCM connector.	Check TCM power supply line and grounding line.

DIAGNOSTIC PROCEDURE WITH DIAGNOSTIC TROUBLE CODE (DTC)

Engine (Diagnostics)

BZ: DTC P1110 — ATMOSPHERIC PRESSURE SENSOR CIRCUIT LOW INPUT — S078521B84

● DTC DETECTING CONDITION:

- Two consecutive driving cycles with fault

CAUTION:

After repair or replacement of faulty parts, conduct Clear Memory Mode <Ref. to EN-55, OPERATION, Clear Memory Mode.> and Inspection Mode <Ref. to EN-48, OPERATION, Inspection Mode.>.

No.	Step	Check	Yes	No
1	CHECK ANY OTHER DTC ON DISPLAY.	Does the Subaru Select Monitor or OBD-II general scan tool indicate DTC P1110?	Replace ECM. <Ref. to FU-51, Engine Control Module.> NOTE: Atmospheric pressure sensor is built into ECM.	It is not necessary to inspect DTC P1110.

CA: DTC P1111 — ATMOSPHERIC PRESSURE SENSOR CIRCUIT HIGH INPUT — S078521B85

● DTC DETECTING CONDITION:

- Two consecutive driving cycles with fault

CAUTION:

After repair or replacement of faulty parts, conduct Clear Memory Mode <Ref. to EN-55, OPERATION, Clear Memory Mode.> and Inspection Mode <Ref. to EN-48, OPERATION, Inspection Mode.>.

No.	Step	Check	Yes	No
1	CHECK ANY OTHER DTC ON DISPLAY.	Does the Subaru Select Monitor or OBD-II general scan tool indicate DTC P1111?	Replace ECM. <Ref. to FU-51, Engine Control Module.> NOTE: Atmospheric pressure sensor is built into ECM.	It is not necessary to inspect DTC P1111.

CB: DTC P1112 — ATMOSPHERIC PRESSURE SENSOR CIRCUIT RANGE/ PERFORMANCE PROBLEM — S078521B86

● DTC DETECTING CONDITION:

- Two consecutive driving cycles with fault

CAUTION:

After repair or replacement of faulty parts, conduct Clear Memory Mode <Ref. to EN-55, OPERATION, Clear Memory Mode.> and Inspection Mode <Ref. to EN-48, OPERATION, Inspection Mode.>.

No.	Step	Check	Yes	No
1	CHECK ANY OTHER DTC ON DISPLAY.	Is any other DTC displayed?	Inspect the relevant DTC using "List of Diagnostic Trouble Code (DTC)". <Ref. to EN-88, List of Diagnostic Trouble Code (DTC).>	Replace ECM. <Ref. to FU-51, Engine Control Module.> NOTE: Atmospheric pressure sensor is built into ECM.

DIAGNOSTIC PROCEDURE WITH DIAGNOSTIC TROUBLE CODE (DTC)

Engine (Diagnostics)

CC: DTC P1137 — FRONT OXYGEN (A/F) SENSOR CIRCUIT RANGE/PERFORMANCE PROBLEM —

S078521G49

● DTC DETECTING CONDITION:

- Two consecutive driving cycles with fault

CAUTION:

After repair or replacement of faulty parts, conduct Clear Memory Mode <Ref. to EN-55, OPERATION, Clear Memory Mode.> and Inspection Mode <Ref. to EN-48, OPERATION, Inspection Mode.>.

● WIRING DIAGRAM:

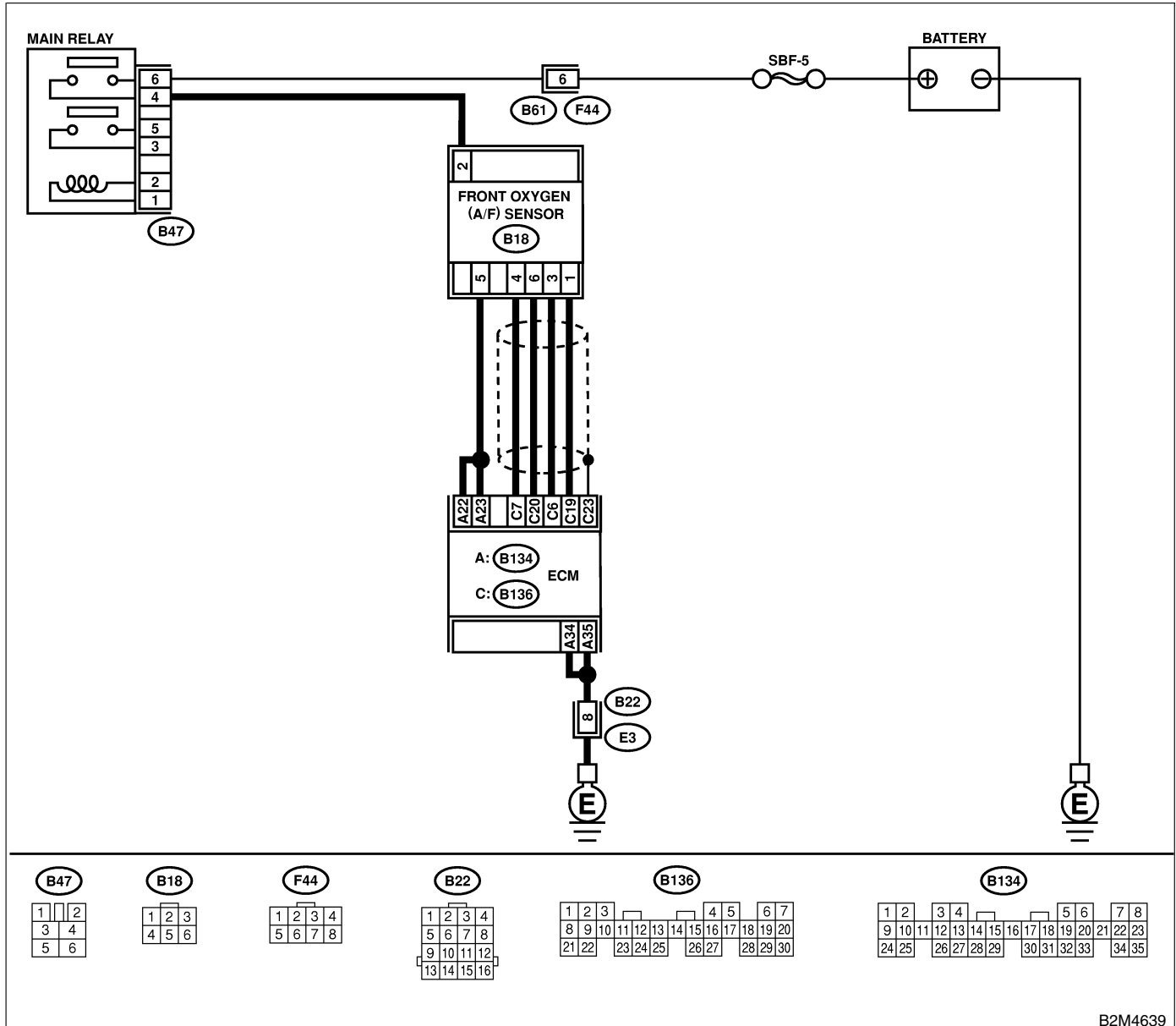

B2M4639

DIAGNOSTIC PROCEDURE WITH DIAGNOSTIC TROUBLE CODE (DTC)

Engine (Diagnostics)

No.	Step	Check	Yes	No
1	CHECK ANY OTHER DTC ON DISPLAY.	Is any other DTC displayed?	Inspect the relevant DTC using "List of Diagnostic Trouble Code (DTC)". <Ref. to EN-88, List of Diagnostic Trouble Code (DTC).>	Go to step 2.
2	CHECK FRONT OXYGEN (A/F) SENSOR DATA. 1) Start engine. 2) While observing the Subaru Select Monitor or OBD-II general scan tool screen, warm-up the engine until coolant temperature is above 70°C (158°F). If the engine is already warmed-up, operate at idle speed for at least 1 minute. 3) Read data of front oxygen (A/F) sensor signal using Subaru Select Monitor or OBD-II general scan tool. NOTE: ● Subaru Select Monitor For detailed operation procedure, refer to the "READ CURRENT DATA FOR ENGINE". <Ref. to EN-36, Subaru Select Monitor.> ● OBD-II general scan tool For detailed operation procedures, refer to the OBD-II General Scan Tool Instruction Manual.	Is the value equal to or more than 0.85 and equal to less than 1.15 in idling?	Go to step 3.	Go to step 4.
3	CHECK FRONT OXYGEN (A/F) SENSOR DATA. Race engine at speeds from idling to 5,000 rpm for a total of 5 cycles. NOTE: To increase engine speed to 5,000 rpm, slowly depress accelerator pedal, taking approximately 5 seconds, and quickly release accelerator pedal to decrease engine speed.	Is the value more than 1.1 for a moment?	Go to step 6.	Go to step 4.
4	CHECK HARNESS BETWEEN ECM AND FRONT OXYGEN (A/F) SENSOR. 1) Turn ignition switch to OFF. 2) Disconnect connector from ECM and front oxygen (A/F) sensor connector. 3) Measure resistance between ECM and front oxygen (A/F) sensor. Connector & terminals (B136) No. 6 — (B18) No. 1: (B136) No. 7 — (B18) No. 6: (B136) No. 19 — (B18) No. 3: (B136) No. 20 — (B18) No. 4:	Is the resistance less than 5 Ω?	Go to step 5.	Repair open circuit between ECM and front oxygen (A/F) sensor.
5	CHECK HARNESS BETWEEN ECM AND FRONT OXYGEN (A/F) SENSOR. Measure resistance between ECM and chassis ground. Connector & terminals (B136) No. 6 — Chassis ground: (B136) No. 7 — Chassis ground: (B136) No. 19 — Chassis ground: (B136) No. 20 — Chassis ground:	Is the resistance more than 1 MΩ?	Go to step 6.	Repair ground short circuit between ECM and front oxygen (A/F) sensor.

DIAGNOSTIC PROCEDURE WITH DIAGNOSTIC TROUBLE CODE (DTC)

Engine (Diagnostics)

No.	Step	Check	Yes	No
6	CHECK EXHAUST SYSTEM. Check exhaust system parts. NOTE: Check the following items. <ul style="list-style-type: none">● Loose installation of portions● Damage (crack, hole etc.) of parts● Looseness of front oxygen (A/F) sensor● Looseness and ill fitting of parts between front oxygen (A/F) sensor and rear oxygen sensor	Is there a fault in exhaust system?	Repair or replace faulty parts.	Replace front oxygen (A/F) sensor. <Ref. to FU-47, Front Oxygen (A/F) Sensor.>

MEMO:

DIAGNOSTIC PROCEDURE WITH DIAGNOSTIC TROUBLE CODE (DTC)

Engine (Diagnostics)

CD: DTC P1142 — THROTTLE POSITION SENSOR CIRCUIT RANGE/PERFORMANCE PROBLEM (LOW INPUT) — S078521B99

● DTC DETECTING CONDITION:

- Two consecutive driving cycles with fault

● TROUBLE SYMPTOM:

- Erroneous idling
- Engine stalls.
- Poor driving performance

CAUTION:

After repair or replacement of faulty parts, conduct Clear Memory Mode <Ref. to EN-55, OPERATION, Clear Memory Mode.> and Inspection Mode <Ref. to EN-48, OPERATION, Inspection Mode.>.

● WIRING DIAGRAM:

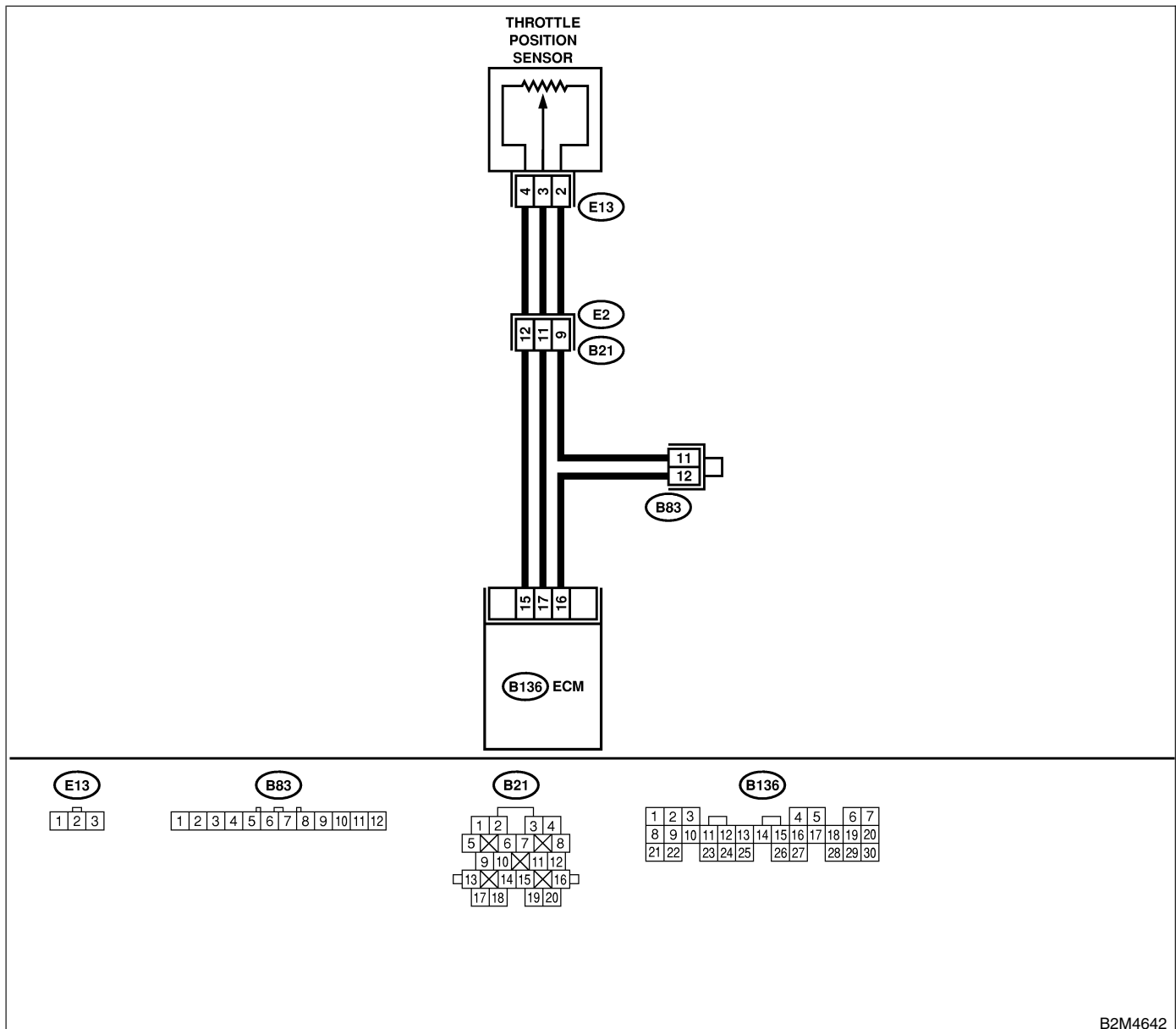

DIAGNOSTIC PROCEDURE WITH DIAGNOSTIC TROUBLE CODE (DTC)

Engine (Diagnostics)

No.	Step	Check	Yes	No
1	CHECK ANY OTHER DTC ON DISPLAY.	Is any other DTC displayed?	Inspect the relevant DTC using "List of Diagnostic Trouble Code (DTC)". <Ref. to EN-88, List of Diagnostic Trouble Code (DTC).> NOTE: In this case, it is not necessary to inspect DTC P1142.	Replace throttle position sensor. <Ref. to FU-35, INSTALLATION, Throttle Position Sensor.>

DIAGNOSTIC PROCEDURE WITH DIAGNOSTIC TROUBLE CODE (DTC)

Engine (Diagnostics)

CE: DTC P1146 — PRESSURE SENSOR CIRCUIT RANGE/PERFORMANCE PROBLEM (HIGH INPUT) — S078521G07

● DTC DETECTING CONDITION:

- Two consecutive driving cycles with fault

CAUTION:

After repair or replacement of faulty parts, conduct Clear Memory Mode <Ref. to EN-55, OPERATION, Clear Memory Mode.> and Inspection Mode <Ref. to EN-48, OPERATION, Inspection Mode.>.

● WIRING DIAGRAM:

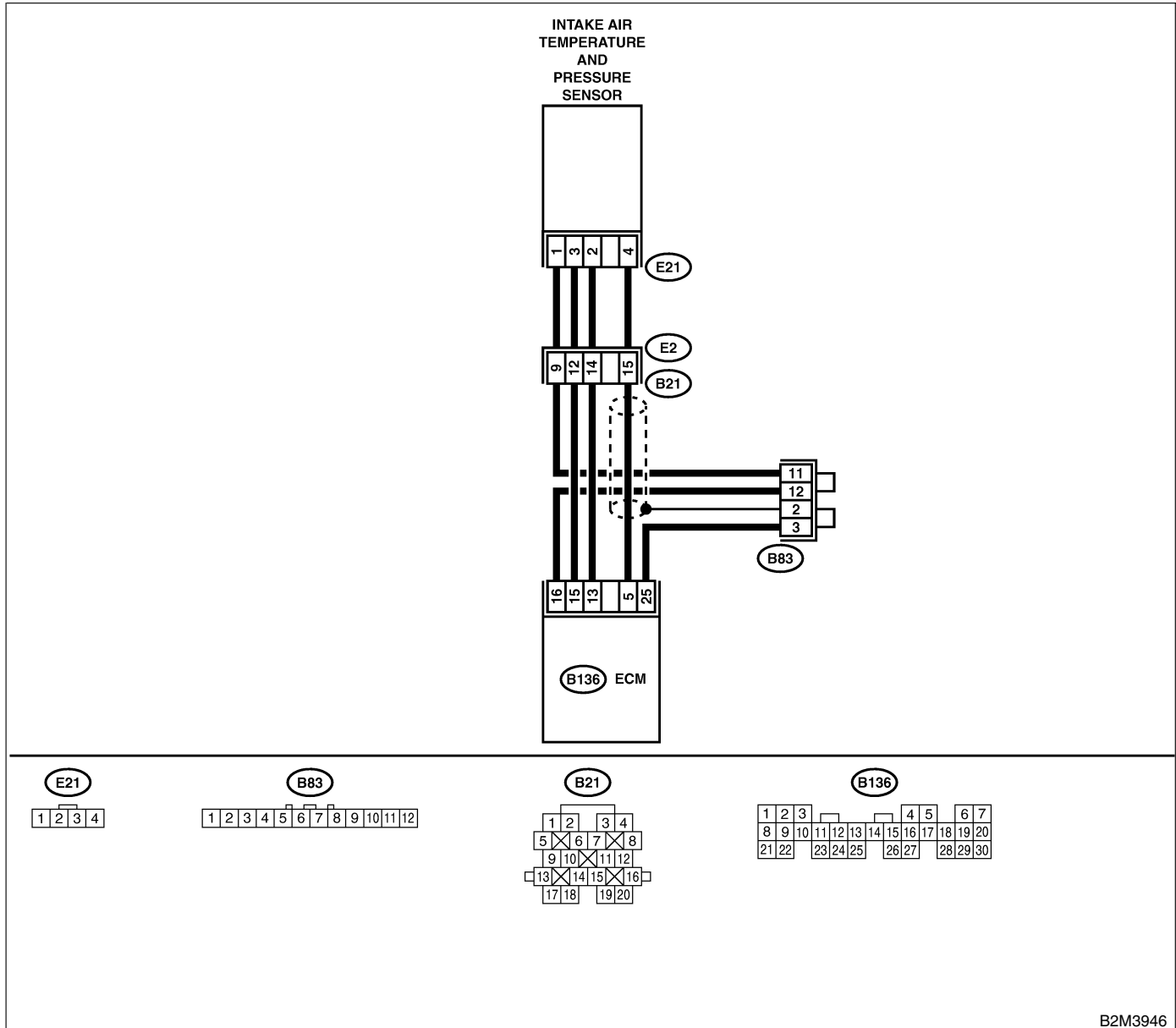

B2M3946

DIAGNOSTIC PROCEDURE WITH DIAGNOSTIC TROUBLE CODE (DTC)

Engine (Diagnostics)

No.	Step	Check	Yes	No
1	<p>CHECK ANY OTHER DTC ON DISPLAY.</p> <p>NOTE: In this case, it is not necessary to inspect DTC P0106.</p>	Is any other DTC displayed?	Inspect the relevant DTC using "List of Diagnostic Trouble Code (DTC)". <Ref. to EN-88, List of Diagnostic Trouble Code (DTC).>	Go to step 2.
2	<p>CHECK AIR INTAKE SYSTEM.</p>	Are there holes, loose bolts or disconnection of hose on air intake system?	Repair air intake system.	Go to step 3.
3	<p>CHECK PRESSURE SENSOR.</p> <p>1) Start the engine and warm-up engine until coolant temperature is greater than 60°C (140°F). 2) Place the shift lever in the selector lever in "N" or "P" position. 3) Turn A/C switch to OFF. 4) Turn all accessory switches to OFF. 5) Read data of intake manifold pressure sensor signal using Subaru Select Monitor or OBD-II general scan tool.</p> <p>NOTE:</p> <ul style="list-style-type: none"> ● Subaru Select Monitor For detailed operation procedure, refer to the "READ CURRENT DATA FOR ENGINE". <Ref. to EN-36, Subaru Select Monitor.> ● OBD-II general scan tool For detailed operation procedure, refer to the OBD-II General Scan Tool Instruction Manual. <p>Specification:</p> <ul style="list-style-type: none"> ● Intake manifold absolute pressure <p>Ignition ON 73.3 — 106.6 kPa (550 — 800 mmHg, 21.65 — 31.50 inHg)</p> <p>Idling 20.0 — 46.7 kPa (150 — 350 mmHg, 5.91 — 13.78 inHg)</p>	Is the value within the specifications?	Go to step 4.	Replace intake air temperature sensor and pressure sensor. <Ref. to FU-38, Intake Air Temperature and Pressure Sensor.>
4	<p>CHECK THROTTLE POSITION.</p> <p>Read data of throttle position signal using Subaru Select Monitor or OBD-II general scan tool.</p> <p>NOTE:</p> <ul style="list-style-type: none"> ● Subaru Select Monitor For detailed operation procedure, refer to the "READ CURRENT DATA FOR ENGINE". <Ref. to EN-36, Subaru Select Monitor.> ● OBD-II general scan tool For detailed operation procedure, refer to the OBD-II General Scan Tool Instruction Manual. 	Is throttle positioning ratio equal to or less than 5% when throttle is fully closed?	Go to step 5.	Adjust or replace throttle position sensor. <Ref. to FU-35, Throttle Position Sensor.>
5	<p>CHECK THROTTLE POSITION.</p>	Is throttle positioning ratio equal to or more than 85% when throttle is fully open?	Replace intake air temperature and pressure sensor. <Ref. to FU-38, Intake Air Temperature and Pressure Sensor.>	Replace throttle position sensor. <Ref. to FU-35, Throttle Position Sensor.>

DIAGNOSTIC PROCEDURE WITH DIAGNOSTIC TROUBLE CODE (DTC)

Engine (Diagnostics)

CF: DTC P1400 — FUEL TANK PRESSURE CONTROL SOLENOID VALVE CIRCUIT LOW INPUT — S078521C07

● DTC DETECTING CONDITION:

- Two consecutive driving cycles with fault

CAUTION:

After repair or replacement of faulty parts, conduct Clear Memory Mode <Ref. to EN-55, OPERATION, Clear Memory Mode.> and Inspection Mode <Ref. to EN-48, OPERATION, Inspection Mode.>.

● WIRING DIAGRAM:

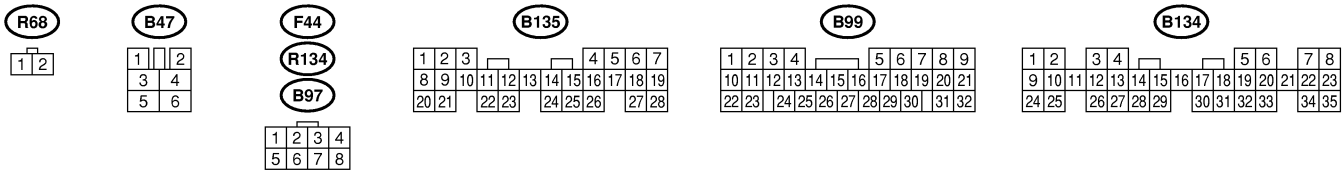
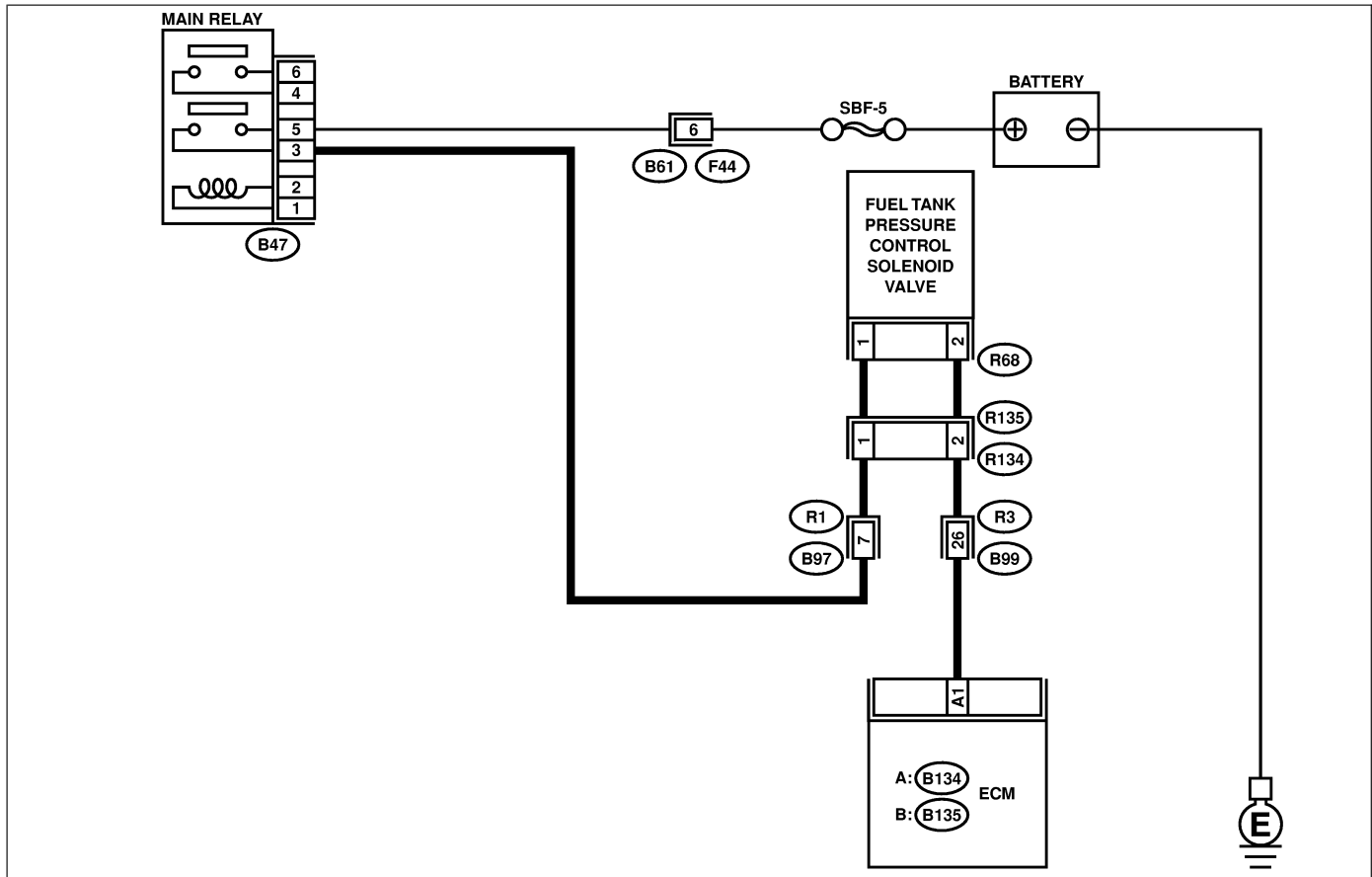

B2M4650

No.	Step	Check	Yes	No
1	CHECK OUTPUT SIGNAL FROM ECM. 1) Turn ignition switch to ON. 2) Measure voltage between ECM and chassis ground. Connector & terminal (B134) No. 1 (+) — Chassis ground (-):	Is the voltage more than 10 V?	Go to step 2.	Go to step 3.

DIAGNOSTIC PROCEDURE WITH DIAGNOSTIC TROUBLE CODE (DTC)

Engine (Diagnostics)

No.	Step	Check	Yes	No
2	<p>CHECK POOR CONTACT. Check poor contact in ECM connector.</p>	Is there poor contact in ECM connector?	Repair poor contact in ECM connector.	Contact with SOA (distributor) service. NOTE: Inspection by DTM is required, because probable cause is deterioration of multiple parts.
3	<p>CHECK HARNESS BETWEEN FUEL TANK PRESSURE CONTROL SOLENOID VALVE AND ECM CONNECTOR. 1) Turn ignition switch to OFF. 2) Disconnect connectors from fuel tank pressure control solenoid valve and ECM. 3) Measure resistance of harness between fuel tank pressure control solenoid valve connector and chassis ground. <i>Connector & terminal</i> <i>(R68) No. 2 — Chassis ground:</i></p>	Is the resistance less than 10 Ω?	Repair ground short circuit in harness between ECM and fuel tank pressure control solenoid valve connector.	Go to step 4.
4	<p>CHECK HARNESS BETWEEN FUEL TANK PRESSURE CONTROL SOLENOID VALVE AND ECM CONNECTOR. Measure resistance of harness between ECM and fuel tank pressure control solenoid valve connector. <i>Connector & terminal</i> <i>(B134) No. 1 — (R68) No. 2:</i></p>	Is the voltage less than 1 Ω?	Go to step 5.	Repair harness and connector. NOTE: In this case, repair the following: ● Open circuit in harness between ECM and fuel tank pressure control solenoid valve connector ● Poor contact in coupling connectors
5	<p>CHECK FUEL TANK PRESSURE CONTROL SOLENOID VALVE. Measure resistance between fuel tank pressure control solenoid valve terminals. <i>Terminals</i> <i>No. 1 — No. 2:</i></p>	Is the resistance between 10 and 100 Ω?	Go to step 6.	Replace fuel tank pressure control solenoid valve. <Ref. to EC-12, Pressure Control Solenoid Valve.>
6	<p>CHECK POWER SUPPLY TO FUEL TANK PRESSURE CONTROL SOLENOID VALVE. 1) Turn ignition switch to ON. 2) Measure voltage between fuel tank pressure control solenoid valve and chassis ground. <i>Connector & terminal</i> <i>(R68) No. 1 (+) — Chassis ground (-):</i></p>	Is the voltage more than 10 V?	Go to step 7.	Repair harness and connector. NOTE: In this case, repair the following: ● Open circuit in harness between main relay and fuel tank pressure control solenoid valve connector ● Poor contact in coupling connectors ● Poor contact in main relay connector

DIAGNOSTIC PROCEDURE WITH DIAGNOSTIC TROUBLE CODE (DTC)

Engine (Diagnostics)

No.	Step	Check	Yes	No
7	CHECK POOR CONTACT. Check poor contact in fuel tank pressure control solenoid valve connector.	Is there poor contact in fuel tank pressure control solenoid valve connector?	Repair poor contact in fuel tank pressure control solenoid valve connector.	Contact with SOA (distributor) service. NOTE: Inspection by DTM is required, because probable cause is deterioration of multiple parts.

MEMO:

DIAGNOSTIC PROCEDURE WITH DIAGNOSTIC TROUBLE CODE (DTC)

Engine (Diagnostics)

CG: P1420 — FUEL TANK PRESSURE CONTROL SOLENOID VALVE CIRCUIT HIGH INPUT — S078521C08

● DTC DETECTING CONDITION:

- Two consecutive driving cycles with fault

CAUTION:

After repair or replacement of faulty parts, conduct Clear Memory Mode <Ref. to EN-55, OPERATION, Clear Memory Mode.> and Inspection Mode <Ref. to EN-48, OPERATION, Inspection Mode.>.

● WIRING DIAGRAM:

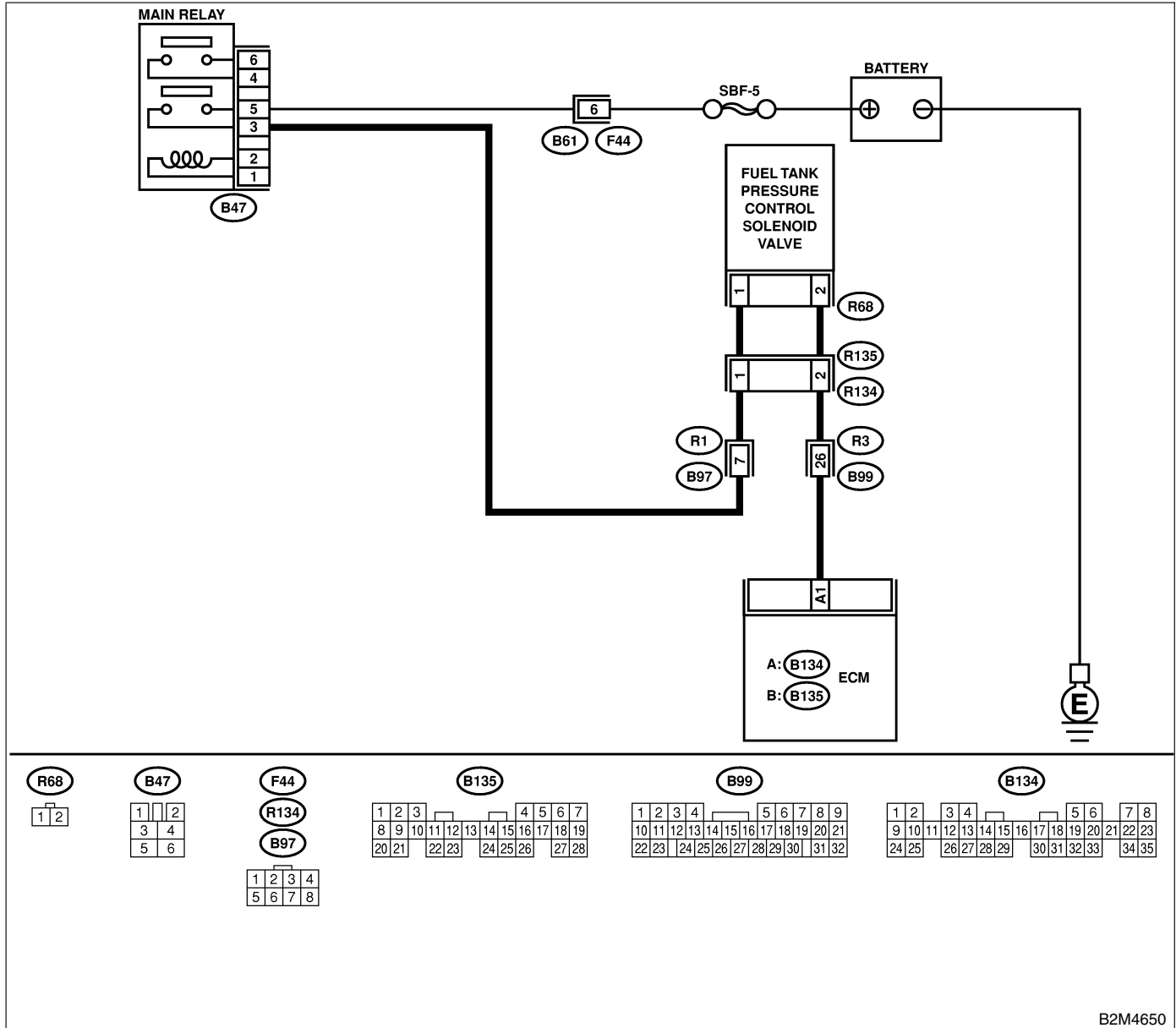

B2M4650

DIAGNOSTIC PROCEDURE WITH DIAGNOSTIC TROUBLE CODE (DTC)

Engine (Diagnostics)

No.	Step	Check	Yes	No
1	<p>CHECK OUTPUT SIGNAL FROM ECM. 1) Turn ignition switch to OFF. 2) Connect test mode connector at the lower portion of instrument panel (on the driver's side), to the side of the center console box. 3) Turn ignition switch to ON. 4) While operating fuel tank pressure control solenoid valve, measure voltage between ECM and chassis ground. NOTE: Fuel tank pressure control solenoid valve operation can be executed using Subaru Select Monitor. For procedure, refer to "Compulsory Valve Operation Check Mode". <Ref. to EN-56, Compulsory Valve Operation Check Mode.> Connector & terminal (B134) No. 1 (+) — Chassis ground (-):</p>	Does voltage change between 0 and 10 V?	Go to step 2.	Even if MIL light up, the circuit has returned to a normal condition at this time. In this case, repair poor contact in ECM connector.
2	<p>CHECK OUTPUT SIGNAL FROM ECM. 1) Turn ignition switch to ON. 2) Measure voltage between ECM and chassis ground. Connector & terminal (B134) No. 1 (+) — Chassis ground (-):</p>	Is the voltage more than 10 V?	Go to step 4.	Go to step 3.
3	<p>CHECK POOR CONTACT. Check poor contact in ECM connector.</p>	Is there poor contact in ECM connector?	Repair poor contact in ECM connector.	Replace ECM. <Ref. to FU-51, Engine Control Module.>
4	<p>CHECK HARNESS BETWEEN FUEL TANK PRESSURE CONTROL SOLENOID VALVE AND ECM CONNECTOR. 1) Turn ignition switch to OFF. 2) Disconnect connector from fuel tank pressure control solenoid valve. 3) Turn ignition switch to ON. 4) Measure voltage between ECM and chassis ground. Connector & terminal (B134) No. 1 (+) — Chassis ground (-):</p>	Is the voltage more than 10 V?	Repair battery short circuit in harness between ECM and fuel tank pressure control solenoid valve connector. After repair, replace ECM. <Ref. to FU-51, Engine Control Module.>	Go to step 5.
5	<p>CHECK FUEL TANK PRESSURE CONTROL SOLENOID VALVE. 1) Turn ignition switch to OFF. 2) Measure resistance between fuel tank pressure control solenoid valve terminals. Terminals No. 1 — No. 2:</p>	Is the resistance less than 1 Ω ?	Replace fuel tank pressure control solenoid valve <Ref. to EC-6, Pressure Control Solenoid Valve.> and ECM <Ref. to FU-51, Engine Control Module.>	Go to step 6.
6	<p>CHECK POOR CONTACT. Check poor contact in ECM connector.</p>	Is there poor contact in ECM connector?	Repair poor contact in ECM connector.	Replace ECM. <Ref. to FU-51, Engine Control Module.>

DIAGNOSTIC PROCEDURE WITH DIAGNOSTIC TROUBLE CODE (DTC)

Engine (Diagnostics)

CH: DTC P1442 — FUEL LEVEL SENSOR CIRCUIT RANGE/PERFORMANCE PROBLEM 2 — S078521C11

● DTC DETECTING CONDITION:

- Two consecutive driving cycles with fault

CAUTION:

After repair or replacement of faulty parts, conduct Clear Memory Mode <Ref. to EN-55, OPERATION, Clear Memory Mode.> and Inspection Mode <Ref. to EN-48, OPERATION, Inspection Mode.>.

● WIRING DIAGRAM:

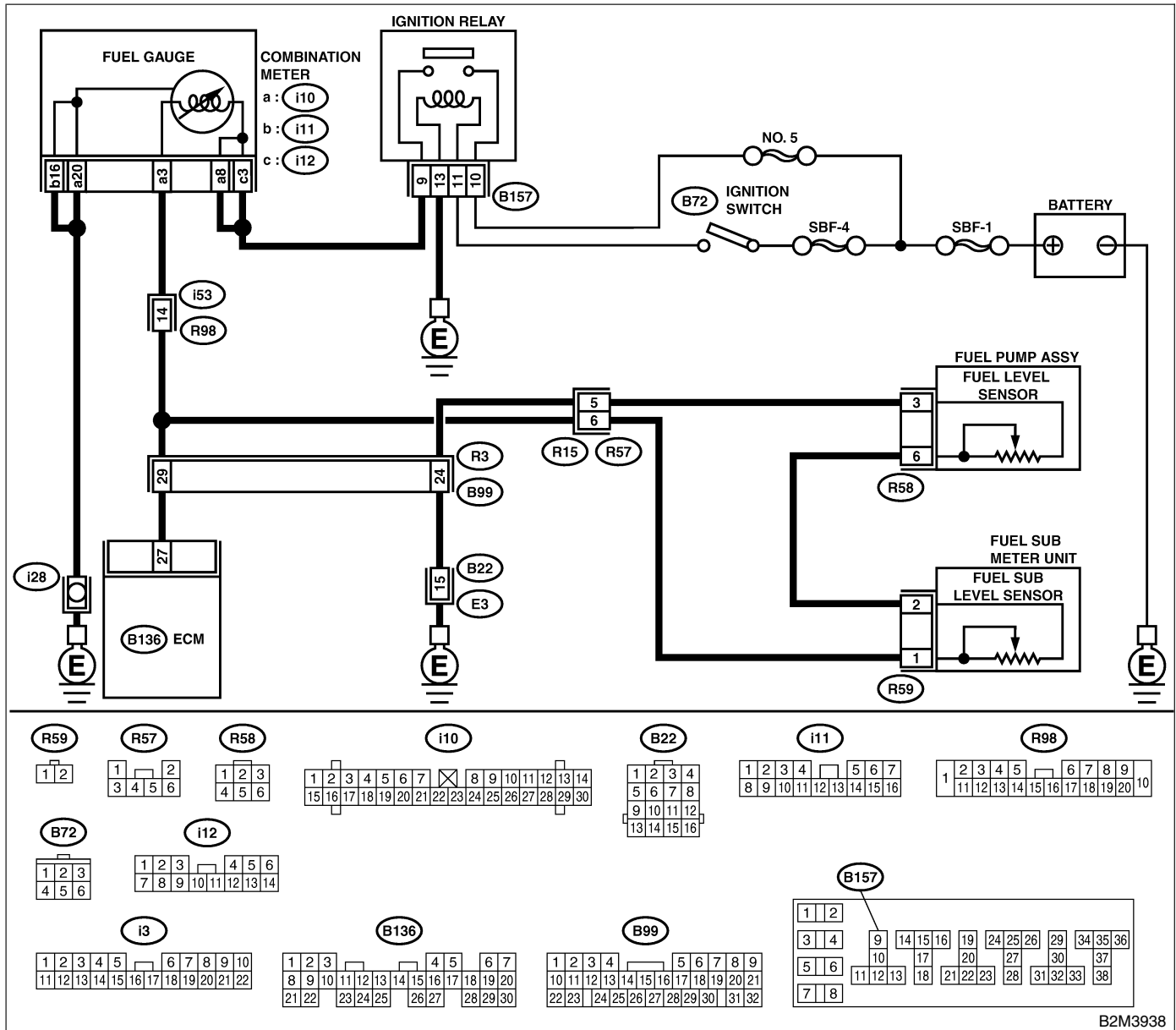

B2M3938

DIAGNOSTIC PROCEDURE WITH DIAGNOSTIC TROUBLE CODE (DTC)

Engine (Diagnostics)

No.	Step	Check	Yes	No
1	CHECK ANY OTHER DTC ON DISPLAY.	Is any other DTC displayed?	Inspect the relevant DTC using "List of Diagnostic Trouble Code (DTC)". <Ref. to EN-88, List of Diagnostic Trouble Code (DTC).> NOTE: In this case, it is not necessary to inspect this trouble.	Replace fuel level sensor <Ref. to FU-76, Fuel Level Sensor.> and fuel sub level sensor. <Ref. to FU-77, Fuel Sub Level Sensor.>

DIAGNOSTIC PROCEDURE WITH DIAGNOSTIC TROUBLE CODE (DTC)

Engine (Diagnostics)

CI: DTC P1443 — EVAPORATIVE EMISSION CONTROL SYSTEM VENT CONTROL FUNCTION PROBLEM — S078521C12

- **DTC DETECTING CONDITION:**
 - Immediately after fault occurrence
- **TROUBLE SYMPTOM:**
 - Improper fuel supply

CAUTION:

After repair or replacement of faulty parts, conduct Clear Memory Mode <Ref. to EN-55, OPERATION, Clear Memory Mode.> and Inspection Mode <Ref. to EN-48, OPERATION, Inspection Mode.>.

● WIRING DIAGRAM:

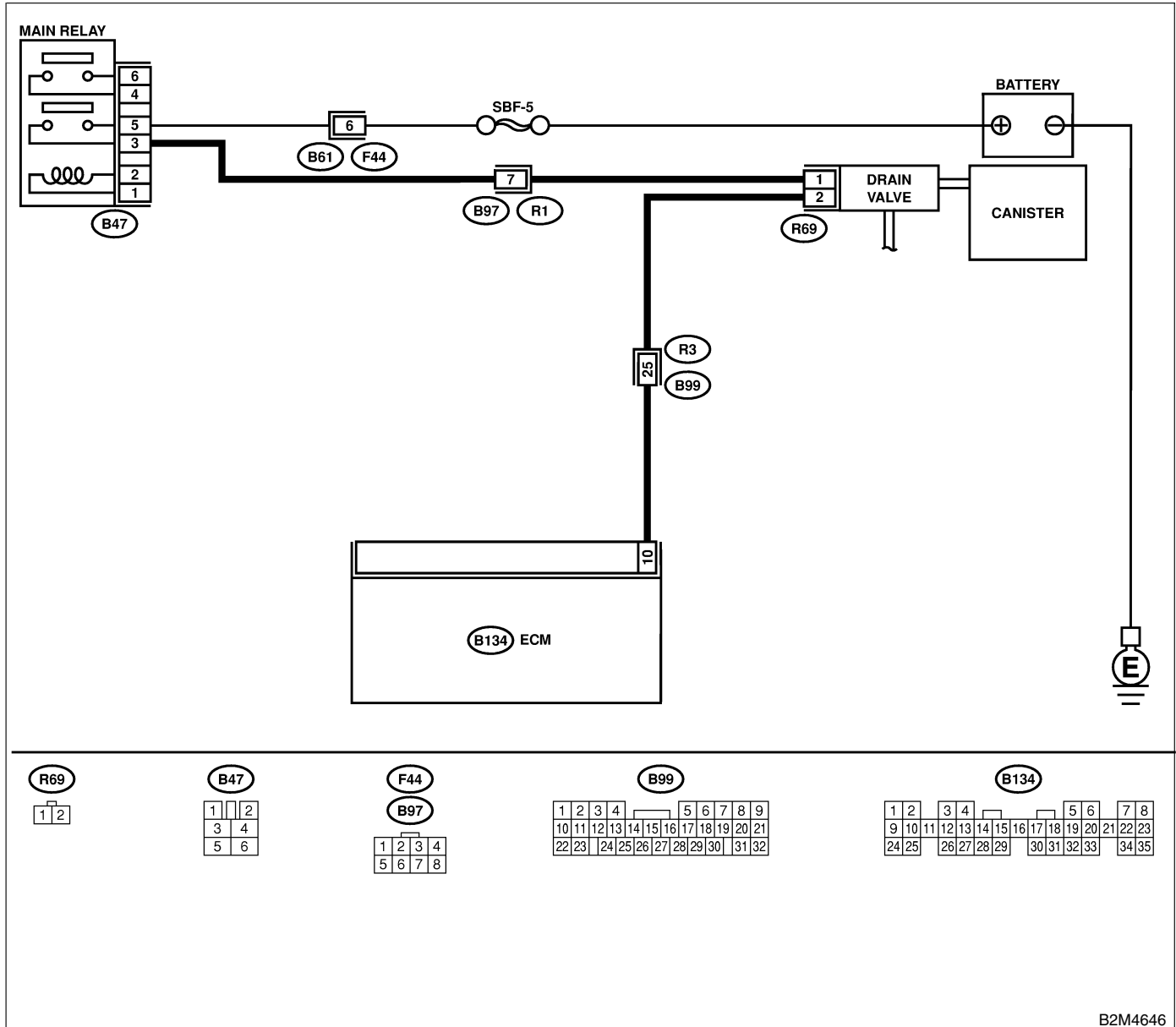

B2M4646

DIAGNOSTIC PROCEDURE WITH DIAGNOSTIC TROUBLE CODE (DTC)

Engine (Diagnostics)

No.	Step	Check	Yes	No
1	CHECK ANY OTHER DTC ON DISPLAY.	Is any other DTC displayed?	Inspect the relevant DTC using "List of Diagnostic Trouble Code (DTC)". <Ref. to EN-88, List of Diagnostic Trouble Code (DTC).>	Go to step 2.
2	CHECK VENT LINE HOSES. Check the following items. <ul style="list-style-type: none">● Clogging of vent hoses between canister and drain valve● Clogging of vent hose between drain valve and air filter● Clogging of drain filter	Is there a fault in vent line?	Repair or replace the faulty part.	Go to step 3.
3	CHECK DRAIN VALVE OPERATION. 1) Turn ignition switch to OFF. 2) Connect test mode connector at the lower portion of instrument panel (on the driver's side), to the side of the center console box. 3) Turn ignition switch to ON. 4) Operate drain valve. NOTE: Drain valve operation can also be executed using Subaru Select Monitor. For the procedure, refer to the "Compulsory Valve Operation Check Mode". <Ref. to EN-56, Compulsory Valve Operation Check Mode.>	Does drain valve produce operating sound?	Contact with SOA (distributor) service. NOTE: Inspection by DTM is required, because probable cause is deterioration of multiple parts.	Replace drain valve. <Ref. to EC-16, Drain Valve.>

DIAGNOSTIC PROCEDURE WITH DIAGNOSTIC TROUBLE CODE (DTC)

Engine (Diagnostics)

CJ: DTC P1446 — EVAPORATIVE EMISSION CONTROL SYSTEM ATMOSPHERIC PRESSURE SOLENOID VALVE LOW INPUT —

S078521K47

● DTC DETECTING CONDITION:

- Two consecutive driving cycles with fault

CAUTION:

After repair or replacement of faulty parts, conduct Clear Memory Mode <Ref. to EN-55, OPERATION, Clear Memory Mode.> and Inspection Mode <Ref. to EN-48, OPERATION, Inspection Mode.>.

● WIRING DIAGRAM:

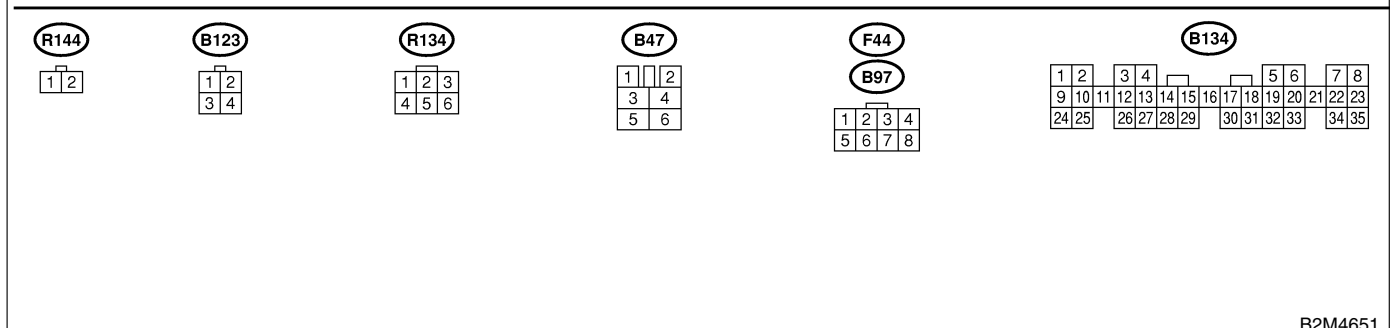
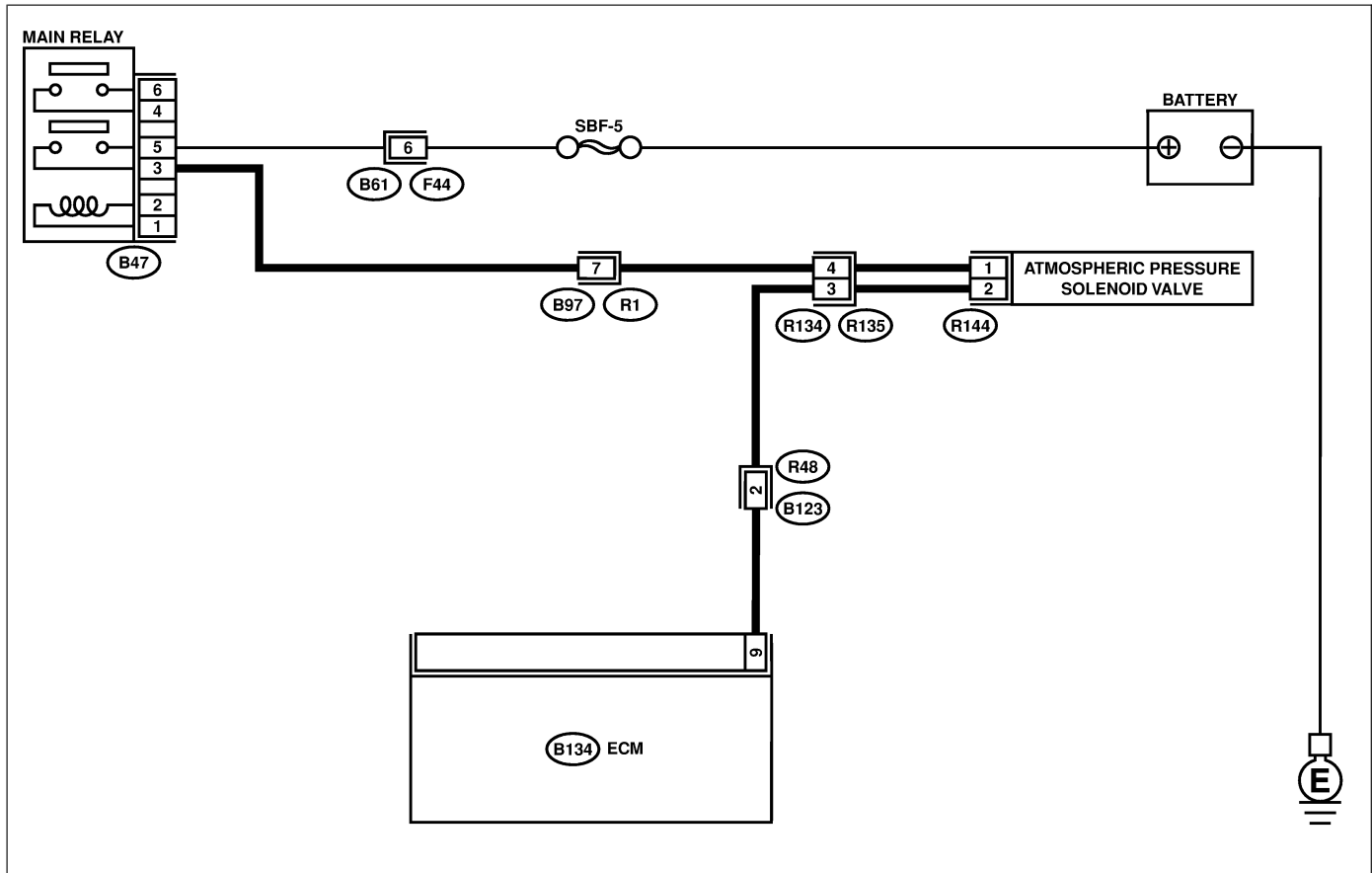

B2M4651

No.	Step	Check	Yes	No
1	CHECK INPUT SIGNAL FOR ECM. 1) Turn ignition switch to ON. 2) Measure voltage between ECM and chassis ground. Connector & terminal (B134) No. 9 (+) — Chassis ground (-):	Is the voltage more than 10 V?	Go to step 2.	Go to step 3.

DIAGNOSTIC PROCEDURE WITH DIAGNOSTIC TROUBLE CODE (DTC)

Engine (Diagnostics)

No.	Step	Check	Yes	No
2	<p>CHECK POOR CONTACT. Check poor contact in ECM connector.</p>	Is there poor contact in ECM connector?	Repair poor contact in ECM connector.	<p>Even if MIL lights up, the circuit has returned to a normal condition at this time. (However, the possibility of poor contact still remains.) NOTE: In this case, repair the following:</p> <ul style="list-style-type: none"> ● Poor contact in drain valve connector ● Poor contact in ECM connector ● Poor contact in coupling connectors
3	<p>CHECK HARNESS BETWEEN ATMOSPHERIC PRESSURE SOLENOID VALVE AND ECM CONNECTOR. 1) Turn ignition switch to OFF. 2) Disconnect connectors from atmospheric pressure solenoid valve and ECM. 3) Measure resistance of harness between drain valve connector and chassis ground. <i>Connector & terminal</i> <i>(R144) No. 2 — Chassis ground:</i></p>	Is the resistance more than 1 MΩ?	Go to step 4.	Repair ground short circuit in harness between ECM and atmospheric pressure solenoid valve connector.
4	<p>CHECK HARNESS BETWEEN ATMOSPHERIC PRESSURE SOLENOID VALVE AND ECM CONNECTOR. Measure resistance of harness between ECM and atmospheric pressure solenoid valve connector. <i>Connector & terminal</i> <i>(B134) No. 9 — (R144) No. 2:</i></p>	Is the voltage less than 1 Ω?	Go to step 5.	<p>Repair harness and connector. NOTE: In this case, repair the following:</p> <ul style="list-style-type: none"> ● Open circuit in harness between ECM and drain valve connector ● Poor contact in coupling connectors
5	<p>CHECK ATMOSPHERIC PRESSURE SOLENOID VALVE. Measure resistance between atmospheric pressure solenoid valve terminals. <i>Terminals</i> <i>No. 1 — No. 2:</i></p>	Is the resistance between 10 and 100 Ω?	Go to step 6.	Replace atmospheric pressure solenoid valve. <Ref. to EC-11, Atmospheric Pressure Solenoid Valve.>

DIAGNOSTIC PROCEDURE WITH DIAGNOSTIC TROUBLE CODE (DTC)

Engine (Diagnostics)

No.	Step	Check	Yes	No
6	<p>CHECK POWER SUPPLY TO ATMOSPHERIC PRESSURE SOLENOID VALVE. 1) Turn ignition switch to ON. 2) Measure voltage between atmospheric pressure solenoid valve and chassis ground. Connector & terminal <i>(R144) No. 1 (+) — Chassis ground (-):</i></p>	Is the voltage more than 10 V?	Go to step 7.	Repair harness and connector. NOTE: In this case, repair the following: <ul style="list-style-type: none"> ● Open circuit in harness between main relay and atmospheric pressure solenoid valve ● Poor contact in coupling connectors ● Poor contact in main relay connector
7	<p>CHECK POOR CONTACT. Check poor contact in atmospheric pressure solenoid valve connector.</p>	Is there poor contact in atmospheric pressure solenoid valve connector?	Repair poor contact in atmospheric pressure solenoid valve connector.	Contact with SOA (distributor) service. NOTE: Inspection by DTM is required, because probable cause is deterioration of multiple parts.

MEMO:

DIAGNOSTIC PROCEDURE WITH DIAGNOSTIC TROUBLE CODE (DTC)

Engine (Diagnostics)

CK: DTC P1447 — EVAPORATIVE EMISSION CONTROL SYSTEM ATMOSPHERIC PRESSURE SOLENOID VALVE HIGH INPUT —

S078521K48

● DTC DETECTING CONDITION:

- Two consecutive driving cycles with fault

CAUTION:

After repair or replacement of faulty parts, conduct Clear Memory Mode <Ref. to EN-55, OPERATION, Clear Memory Mode.> and Inspection Mode <Ref. to EN-48, OPERATION, Inspection Mode.>.

● WIRING DIAGRAM:

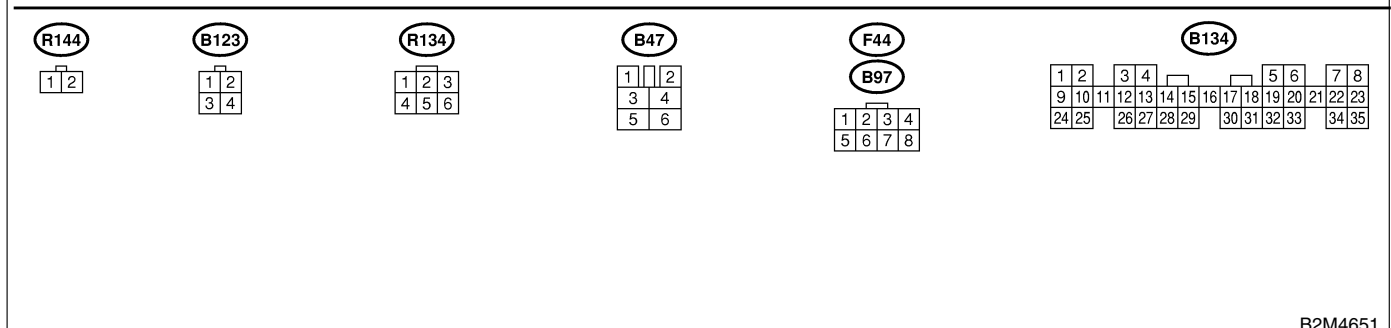
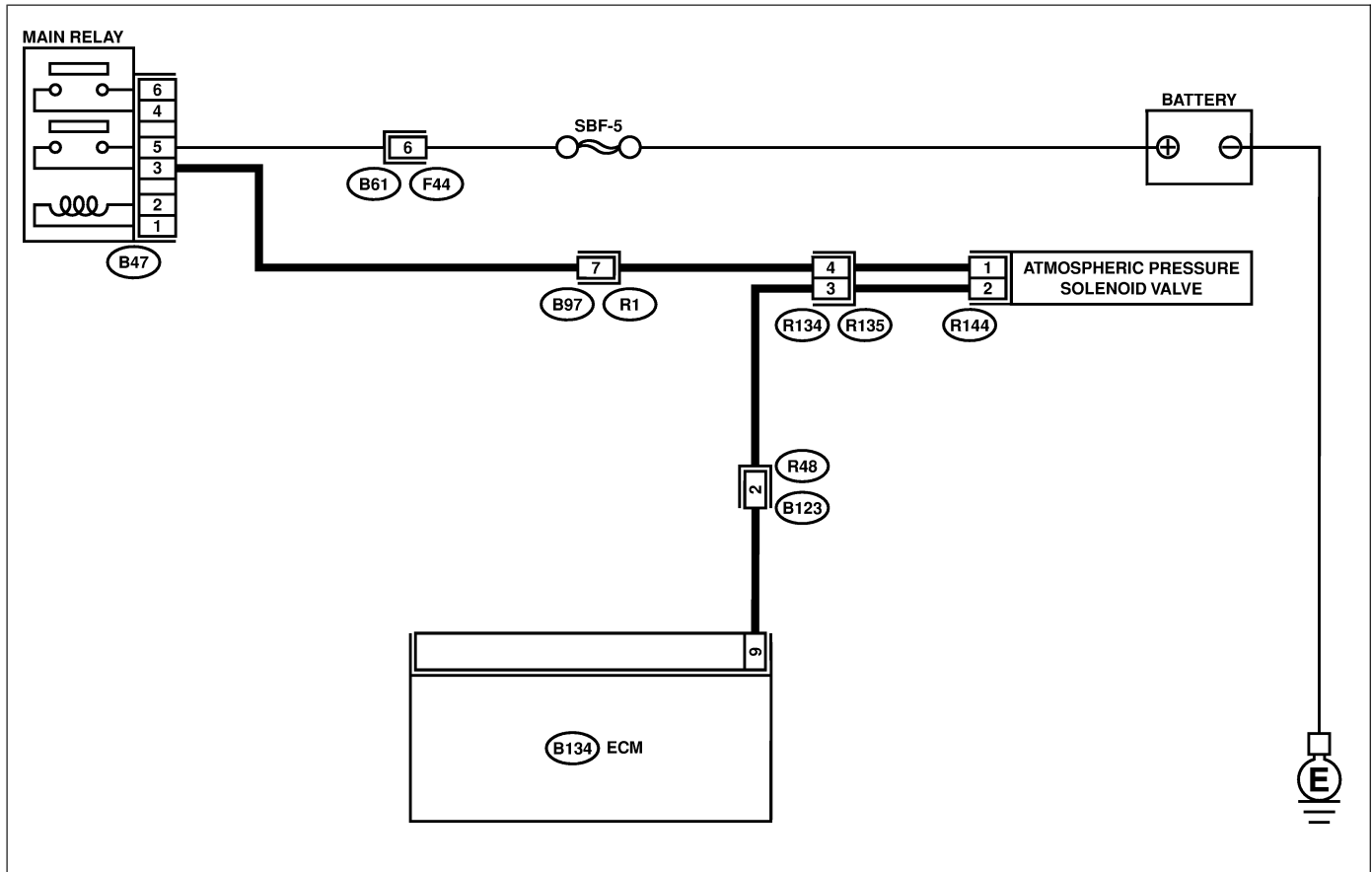

B2M4651

No.	Step	Check	Yes	No
1	CHECK INPUT SIGNAL FOR ECM. 1) Turn ignition switch to ON. 2) Measure voltage between ECM and chassis ground. Connector & terminal (B134) No. 9 (+) — Chassis ground (-):	Is the voltage more than 10 V?	Go to step 3.	Go to step 2.

DIAGNOSTIC PROCEDURE WITH DIAGNOSTIC TROUBLE CODE (DTC)

Engine (Diagnostics)

No.	Step	Check	Yes	No
2	CHECK POOR CONTACT. Check poor contact in ECM connector.	Is there poor contact in ECM connector?	Repair poor contact in ECM connector.	Replace ECM. <Ref. to FU-51, Engine Control Module.>
3	CHECK HARNESS BETWEEN ATMOSPHERIC PRESSURE SOLENOID VALVE AND ECM CONNECTOR. 1) Turn ignition switch to OFF. 2) Disconnect connector from atmospheric pressure solenoid valve. 3) Turn ignition switch to ON. 4) Measure voltage between ECM and chassis ground. <i>Connector & terminal</i> <i>(B134) No. 9 (+) — Chassis ground (-):</i>	Is the voltage more than 10 V?	Repair battery short circuit in harness between ECM and atmospheric pressure solenoid valve connector. After repair, replace ECM. <Ref. to FU-51, Engine Control Module.>	Go to step 4.
4	CHECK DRAIN VALVE. 1) Turn ignition switch to OFF. 2) Measure resistance between atmospheric pressure solenoid valve terminals. <i>Terminals</i> <i>No. 1 — No. 2:</i>	Is the resistance less than 1 Ω ?	Replace atmospheric pressure solenoid valve <Ref. to EC-11, Atmospheric Pressure Solenoid Valve.> and ECM <Ref. to FU-51, Engine Control Module.>	Go to step 5.
5	CHECK POOR CONTACT. Check poor contact in ECM connector.	Is there poor contact in ECM connector?	Repair poor contact in ECM connector.	Replace ECM. <Ref. to FU-51, Engine Control Module.>

DIAGNOSTIC PROCEDURE WITH DIAGNOSTIC TROUBLE CODE (DTC)

Engine (Diagnostics)

CL: DTC P1448 — EVAPORATIVE EMISSION CONTROL SYSTEM ATMOSPHERIC PRESSURE SOLENOID VALVE RANGE/PERFORMANCE PROBLEM — S078521K49

● **DTC DETECTING CONDITION:**

- Two consecutive driving cycles with fault

CAUTION:

After repair or replacement of faulty parts, conduct Clear Memory Mode <Ref. to EN-55, OPERATION, Clear Memory Mode.> and Inspection Mode <Ref. to EN-48, OPERATION, Inspection Mode.>.

● **WIRING DIAGRAM:**

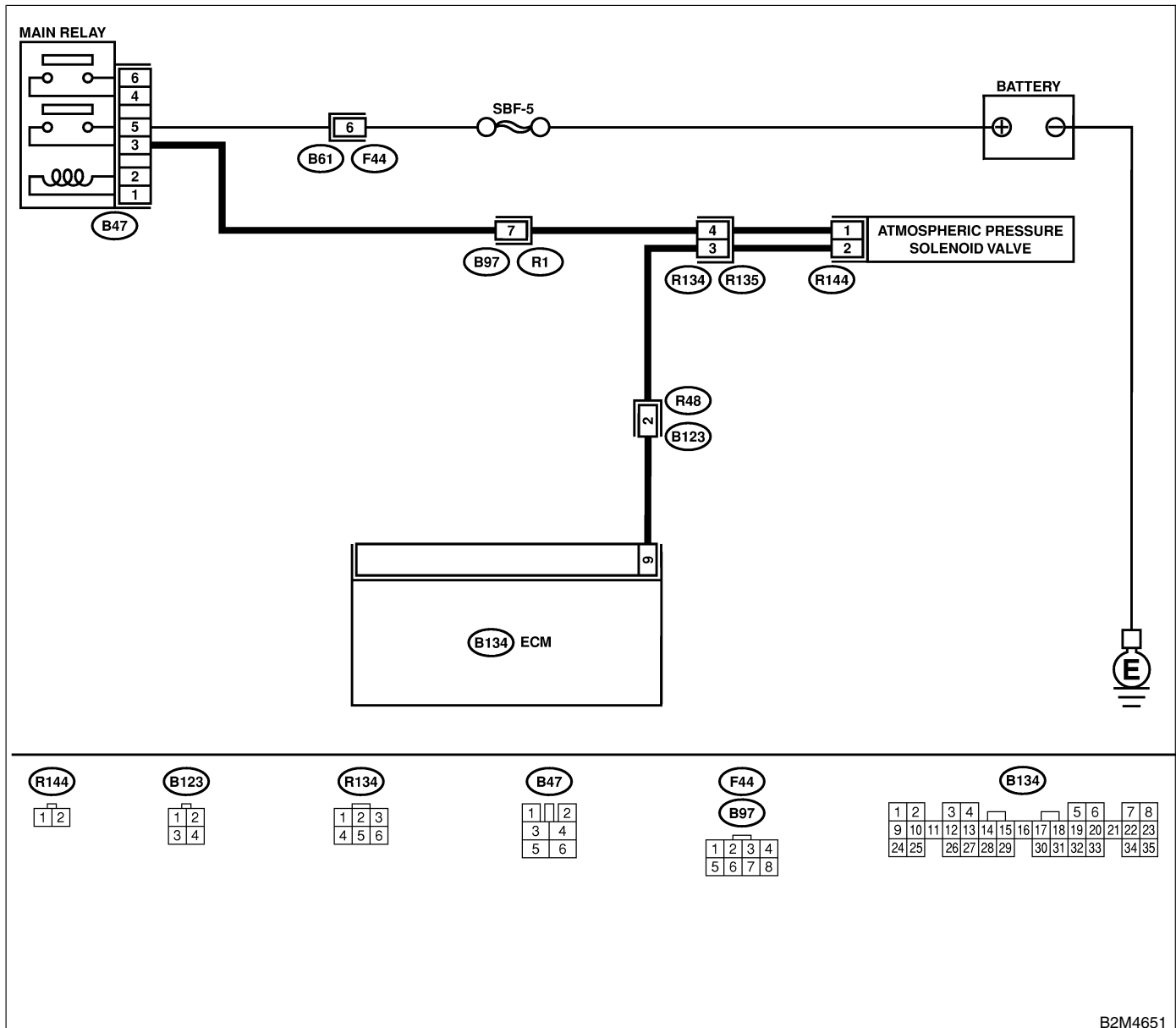

DIAGNOSTIC PROCEDURE WITH DIAGNOSTIC TROUBLE CODE (DTC)

Engine (Diagnostics)

No.	Step	Check	Yes	No
1	CHECK ANY OTHER DTC ON DISPLAY.	Is there any DTC on display?	Inspect the relevant DTC using "List of Diagnostic Trouble Code (DTC)". <Ref. to EN-88, List of Diagnostic Trouble Code (DTC).>	Go to step 2.
2	CHECK FUEL FILLER CAP. 1) Turn ignition switch to OFF. 2) Open the fuel flap.	Is the fuel filler cap tightened securely?	Go to step 3.	Tighten fuel filler cap securely.
3	CHECK PRESSURE/VACUUM LINE. NOTE: Check the following items. <ul style="list-style-type: none">● Disconnection, leakage and clogging of the vacuum hoses and pipes between fuel tank pressure sensor and fuel tank● Disconnection, leakage and clogging of air ventilation hoses and pipes between fuel filler pipe and fuel tank	Is there a fault in pressure/vacuum line?	Repair or replace hoses and pipes.	Replace fuel tank pressure sensor. <Ref. to EC-10, Fuel Tank Pressure Sensor.>

DIAGNOSTIC PROCEDURE WITH DIAGNOSTIC TROUBLE CODE (DTC)

Engine (Diagnostics)

CM: DTC P1507 — IDLE CONTROL SYSTEM MALFUNCTION (FAIL-SAFE) —

S078521C16

- **DTC DETECTING CONDITION:**

- Immediately at fault recognition

- **TROUBLE SYMPTOM:**

- Engine keeps running at higher revolution than specified idling revolution.

CAUTION:

After repair or replacement of faulty parts, conduct Clear Memory Mode <Ref. to EN-55, OPERATION, Clear Memory Mode.> and Inspection Mode <Ref. to EN-48, OPERATION, Inspection Mode.>

- **WIRING DIAGRAM:**

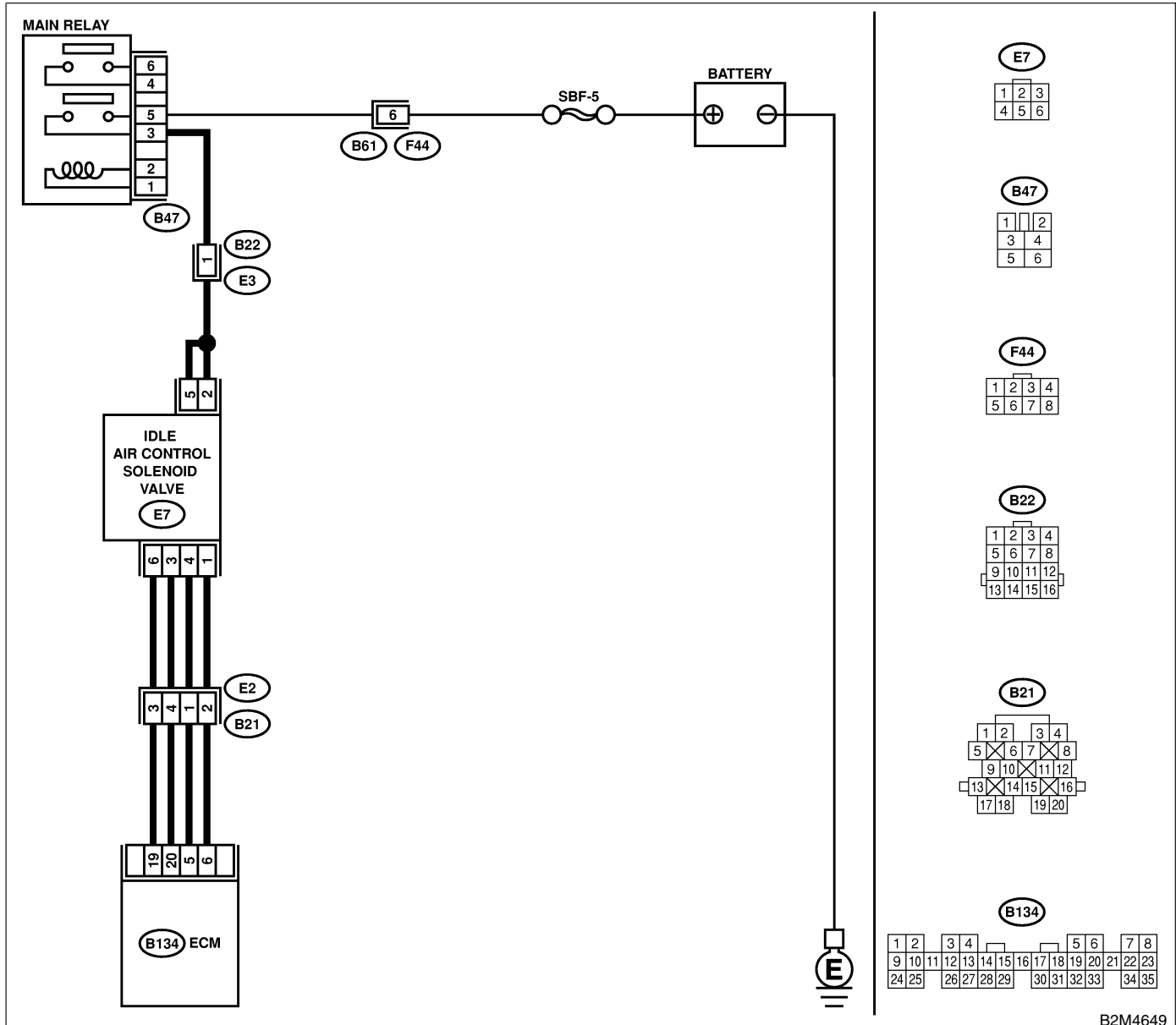

B2M4649

DIAGNOSTIC PROCEDURE WITH DIAGNOSTIC TROUBLE CODE (DTC)

Engine (Diagnostics)

No.	Step	Check	Yes	No
1	CHECK ANY OTHER DTC ON DISPLAY.	Is any other DTC displayed?	Inspect the relevant DTC using "List of Diagnostic Trouble Code (DTC)". <Ref. to EN-88, List of Diagnostic Trouble Code (DTC).> NOTE: In this case, it is not necessary to inspect DTC P0507.	Go to step 2.
2	CHECK AIR INTAKE SYSTEM. 1) Turn ignition switch to ON. 2) Start engine, and idle it. 3) Check the following items. <ul style="list-style-type: none">● Loose installation of intake manifold, idle air control solenoid valve and throttle body● Cracks of intake manifold gasket, idle air control solenoid valve gasket and throttle body gasket● Disconnections of vacuum hoses	Is there a fault in air intake system?	Repair air suction and leaks.	Go to step 3.
3	CHECK THROTTLE CABLE.	Does throttle cable have play for adjustment?	Go to step 4.	Adjust throttle cable. <Ref. to SP-6, INSTALLATION, Accelerator Control Cable.>
4	CHECK AIR BY-PASS LINE. 1) Turn ignition switch to OFF. 2) Remove idle air control solenoid valve from throttle body. <Ref. to FU-39, Idle Air Control Solenoid Valve.> 3) Confirm that there are no foreign particles in by-pass air line.	Are foreign particles in by-pass air line?	Remove foreign particles from by-pass air line.	Replace idle air control solenoid valve. <Ref. to FU-39, Idle Air Control Solenoid Valve.>

DIAGNOSTIC PROCEDURE WITH DIAGNOSTIC TROUBLE CODE (DTC)

Engine (Diagnostics)

CN: DTC P1510 — IDLE AIR CONTROL SOLENOID VALVE SIGNAL 1 CIRCUIT LOW INPUT — S078521C17

NOTE:

For the diagnostic procedure, refer to DTC P1516. <Ref. to EN-326, DTC 1516 — IDLE AIR CONTROL SOLENOID VALVE SIGNAL 4 CIRCUIT LOW INPUT —, Diagnostic Procedure with Diagnostic Trouble Code (DTC).>

CO: DTC P1511 — IDLE AIR CONTROL SOLENOID VALVE SIGNAL 1 CIRCUIT HIGH INPUT — S078521C18

NOTE:

For the diagnostic procedure, refer to DTC P1517. <Ref. to EN-330, DTC 1517 — IDLE AIR CONTROL SOLENOID VALVE SIGNAL 4 CIRCUIT HIGH INPUT —, Diagnostic Procedure with Diagnostic Trouble Code (DTC).>

CP: DTC P1512 — IDLE AIR CONTROL SOLENOID VALVE SIGNAL 2 CIRCUIT LOW INPUT — S078521C19

NOTE:

For the diagnostic procedure, refer to DTC P1516. <Ref. to EN-326, DTC 1516 — IDLE AIR CONTROL SOLENOID VALVE SIGNAL 4 CIRCUIT LOW INPUT —, Diagnostic Procedure with Diagnostic Trouble Code (DTC).>

CQ: DTC P1513 — IDLE AIR CONTROL SOLENOID VALVE SIGNAL 2 CIRCUIT HIGH INPUT — S078521C20

NOTE:

For the diagnostic procedure, refer to DTC P1517. <Ref. to EN-330, DTC 1517 — IDLE AIR CONTROL SOLENOID VALVE SIGNAL 4 CIRCUIT HIGH INPUT —, Diagnostic Procedure with Diagnostic Trouble Code (DTC).>

CR: DTC P1514 — IDLE AIR CONTROL SOLENOID VALVE SIGNAL 3 CIRCUIT LOW INPUT — S078521C21

NOTE:

For the diagnostic procedure, refer to DTC P1516. <Ref. to EN-326, DTC 1516 — IDLE AIR CONTROL SOLENOID VALVE SIGNAL 4 CIRCUIT LOW INPUT —, Diagnostic Procedure with Diagnostic Trouble Code (DTC).>

CS: DTC P1515 — IDLE AIR CONTROL SOLENOID VALVE SIGNAL 3 CIRCUIT HIGH INPUT — S078521C22

NOTE:

For the diagnostic procedure, refer to DTC P1517. <Ref. to EN-330, DTC 1517 — IDLE AIR CONTROL SOLENOID VALVE SIGNAL 4 CIRCUIT HIGH INPUT —, Diagnostic Procedure with Diagnostic Trouble Code (DTC).>

MEMO:

DIAGNOSTIC PROCEDURE WITH DIAGNOSTIC TROUBLE CODE (DTC)

Engine (Diagnostics)

CT: DTC P1516 — IDLE AIR CONTROL SOLENOID VALVE SIGNAL 4 CIRCUIT LOW INPUT — S078521C23

- **DTC DETECTING CONDITION:**
 - Immediately at fault recognition
- **TROUBLE SYMPTOM:**
 - Erroneous idling
 - Engine stalls.
 - Engine breathing

CAUTION:

After repair or replacement of faulty parts, conduct Clear Memory Mode <Ref. to EN-55, OPERATION, Clear Memory Mode.> and Inspection Mode <Ref. to EN-48, OPERATION, Inspection Mode.>.

● **WIRING DIAGRAM:**

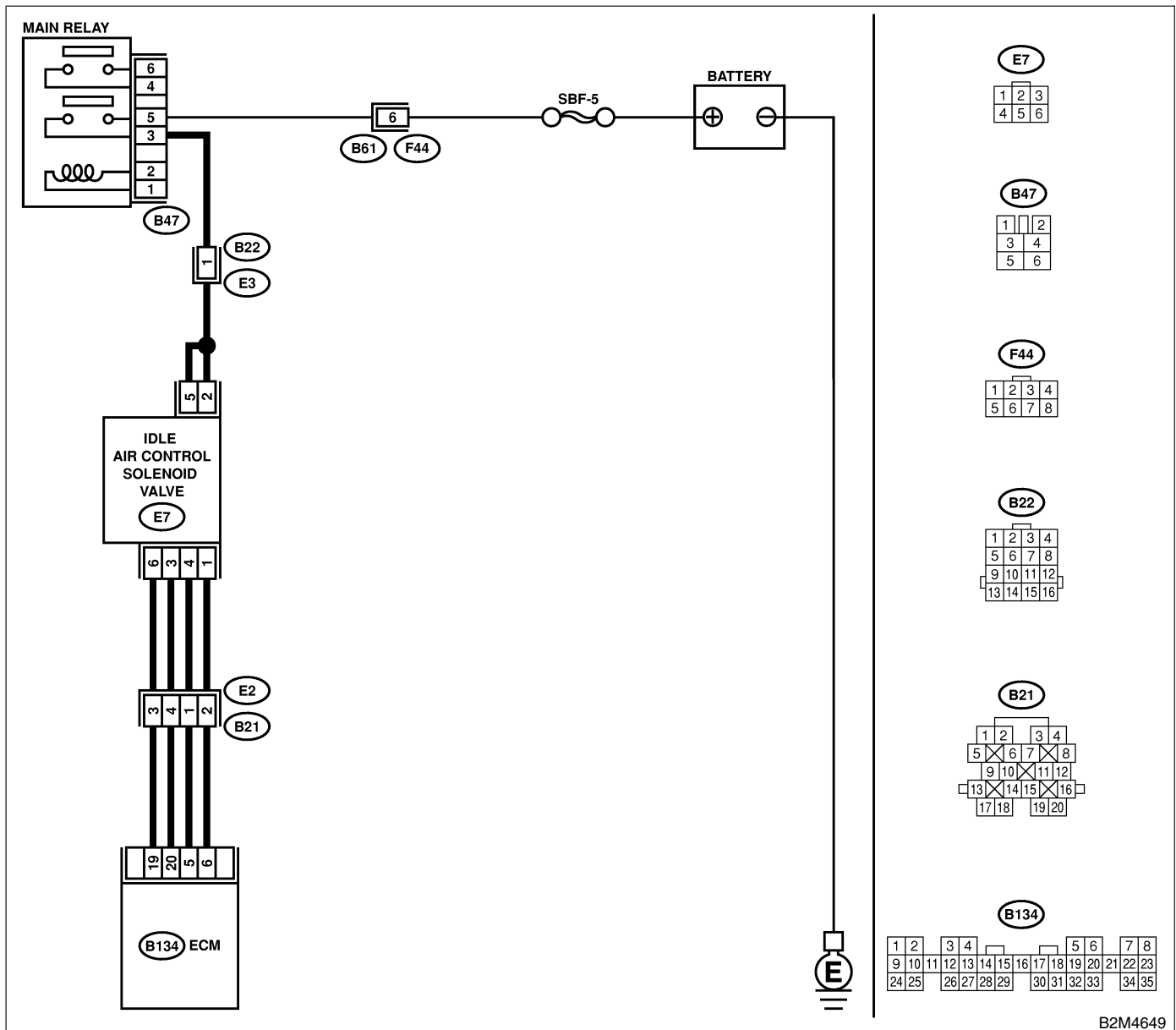

B2M4649

DIAGNOSTIC PROCEDURE WITH DIAGNOSTIC TROUBLE CODE (DTC)

Engine (Diagnostics)

No.	Step	Check	Yes	No
1	<p>CHECK POWER SUPPLY TO IDLE AIR CONTROL SOLENOID VALVE.</p> <p>1) Turn ignition switch to OFF. 2) Disconnect connector from idle air control solenoid valve. 3) Turn ignition switch to ON. 4) Measure voltage between idle air control solenoid valve connector and engine ground.</p> <p>Connector & terminal (E7) No. 2 (+) — Engine ground (-):</p>	Is the voltage more than 10 V?	Go to step 2.	Repair harness and connector. NOTE: In this case, repair the following: ● Open circuit in harness between idle air control solenoid valve and main relay connector ● Poor contact in coupling connector
2	<p>CHECK POWER SUPPLY TO IDLE AIR CONTROL SOLENOID VALVE.</p> <p>Measure voltage between idle air control solenoid valve connector and engine ground.</p> <p>Connector & terminal (E7) No. 5 (+) — Engine ground (-):</p>	Is the voltage more than 10 V?	Go to step 3.	Repair harness and connector. NOTE: In this case, repair the following: ● Open circuit in harness between idle air control solenoid valve and main relay connector ● Poor contact in coupling connector
3	<p>CHECK HARNESS BETWEEN ECM AND IDLE AIR CONTROL SOLENOID VALVE CONNECTOR.</p> <p>1) Turn ignition switch to OFF. 2) Measure resistance between ECM and idle air control solenoid valve connector.</p> <p>Connector & terminal DTC P1510; (B134) No. 5 — (E7) No. 3: DTC P1512; (B134) No. 6 — (E7) No. 1: DTC P1514; (B134) No. 19 — (E7) No. 6: DTC P1516; (B134) No. 20 — (E7) No. 4:</p>	Is the resistance less than 1 Ω?	Go to step 4.	Repair harness and connector. NOTE: In this case, repair the following: ● Open circuit in harness between ECM and idle air control solenoid valve connector ● Poor contact in coupling connector
4	<p>CHECK HARNESS BETWEEN ECM AND IDLE AIR CONTROL SOLENOID VALVE CONNECTOR.</p> <p>1) Disconnect connector from ECM. 2) Measure resistance between ECM connector and chassis ground.</p> <p>Connector & terminal DTC P1510; (B134) No. 5 — Chassis ground: DTC P1512; (B134) No. 6 — Chassis ground: DTC P1514; (B134) No. 19 — Chassis ground: DTC P1516; (B134) No. 20 — Chassis ground:</p>	Is the resistance less than 10 Ω?	Repair ground short circuit in harness between ECM and idle air control solenoid valve connector.	Go to step 5.

DIAGNOSTIC PROCEDURE WITH DIAGNOSTIC TROUBLE CODE (DTC)

Engine (Diagnostics)

No.	Step	Check	Yes	No
5	CHECK POOR CONTACT. Check poor contact in ECM connector and idle air control solenoid valve connector.	Is there poor contact in ECM connector or idle air control solenoid valve connector?	Repair poor contact in ECM connector or idle air control solenoid valve connector.	Replace idle air control solenoid valve. <Ref. to FU-39, Idle Air Control Solenoid Valve.>

MEMO:

DIAGNOSTIC PROCEDURE WITH DIAGNOSTIC TROUBLE CODE (DTC)

Engine (Diagnostics)

CU: DTC P1517 — IDLE AIR CONTROL SOLENOID VALVE SIGNAL 4 CIRCUIT HIGH INPUT — S078521C24

- **DTC DETECTING CONDITION:**
 - Immediately at fault recognition
- **TROUBLE SYMPTOM:**
 - Erroneous idling
 - Engine stalls.
 - Engine breathing

CAUTION:

After repair or replacement of faulty parts, conduct Clear Memory Mode <Ref. to EN-55, OPERATION, Clear Memory Mode.> and Inspection Mode <Ref. to EN-48, OPERATION, Inspection Mode.>.

● **WIRING DIAGRAM:**

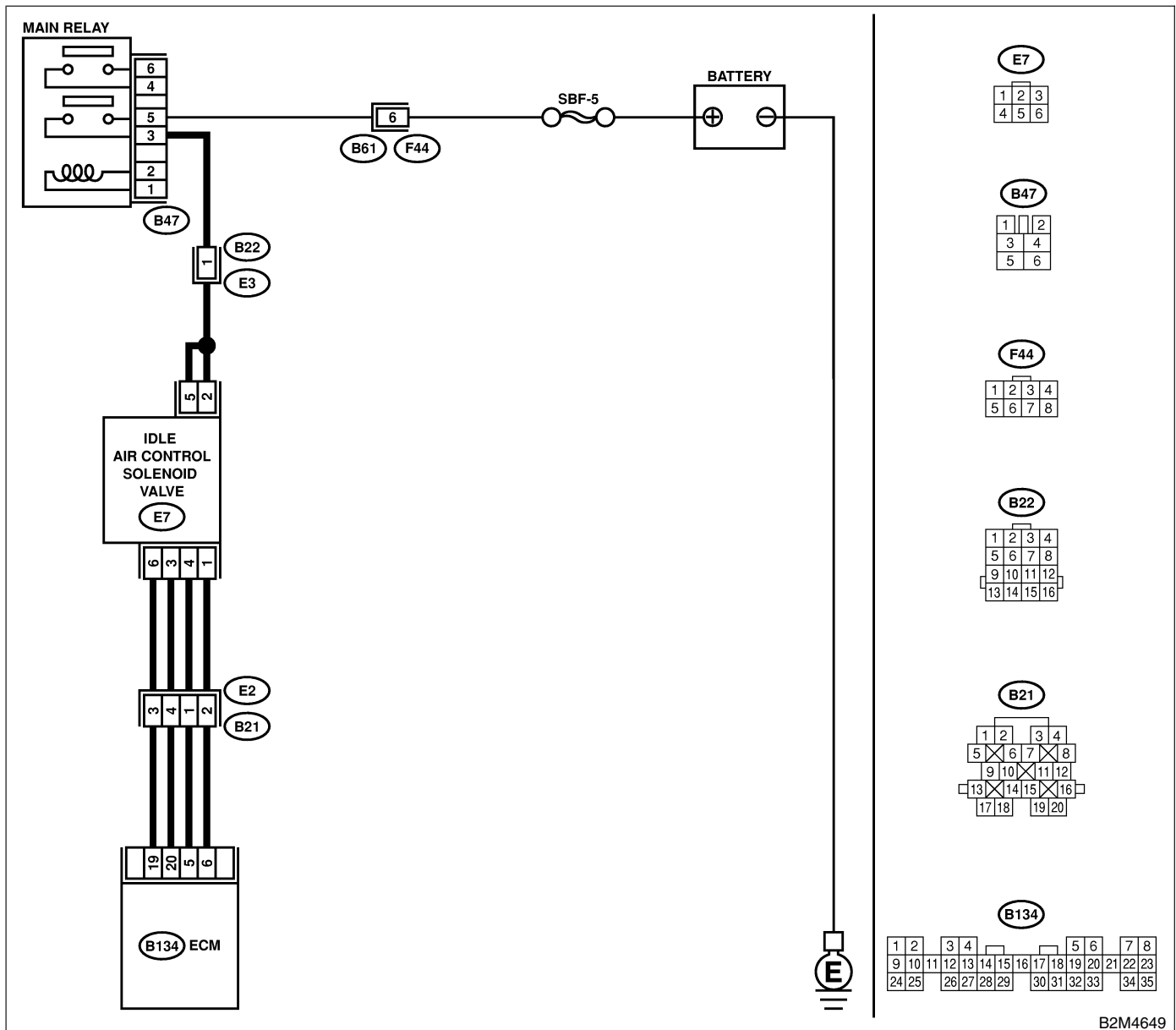

DIAGNOSTIC PROCEDURE WITH DIAGNOSTIC TROUBLE CODE (DTC)

Engine (Diagnostics)

No.	Step	Check	Yes	No
1	CHECK ANY OTHER DTC ON DISPLAY.	Does the Subaru Select Monitor or OBD-II general scan tool indicate DTC P1511, P1513, P1515 and P1517 at same time?	Go to step 2.	Go to step 3.
2	CHECK GROUND CIRCUIT FOR ECM. 1) Turn ignition switch to OFF. 2) Measure resistance between ECM connector and chassis ground. Connector & terminal (B134) No. 7 — Chassis ground:	Is the resistance less than 5 Ω?	Go to step 3.	Repair harness and connector. NOTE: In this case, repair the following: ● Open circuit in harness between ECM connector and engine ground terminal ● Poor contact in ECM connector ● Poor contact in coupling connector
3	CHECK HARNESS BETWEEN ECM AND IDLE AIR CONTROL SOLENOID VALVE CONNECTOR. 1) Turn ignition switch to OFF. 2) Disconnect connector from idle air control solenoid valve. 3) Turn ignition switch to ON. 4) Measure voltage between ECM connector and chassis ground. Connector & terminal DTC P1511; (B134) No. 5 (+) — Chassis ground (-): DTC P1513; (B134) No. 6 (+) — Chassis ground (-): DTC P1515; (B134) No. 19 (+) — Chassis ground (-): DTC P1517; (B134) No. 20 (+) — Chassis ground (-):	Is the voltage more than 10 V?	Repair battery short circuit in harness between ECM and idle air control solenoid valve connector. After repair, replace ECM. <Ref. to FU-51, Engine Control Module.>	Replace ECM. <Ref. to FU-51, Engine Control Module.>

DIAGNOSTIC PROCEDURE WITH DIAGNOSTIC TROUBLE CODE (DTC)

Engine (Diagnostics)

CV: DTC P1518 — STARTER SWITCH CIRCUIT LOW INPUT — S078521G09

- **DTC DETECTING CONDITION:**
 - Two consecutive driving cycles with fault
- **TROUBLE SYMPTOM:**
 - Failure of engine to start

CAUTION:

After repair or replacement of faulty parts, conduct Clear Memory Mode <Ref. to EN-55, OPERATION, Clear Memory Mode.> and Inspection Mode <Ref. to EN-48, OPERATION, Inspection Mode.>.

DIAGNOSTIC PROCEDURE WITH DIAGNOSTIC TROUBLE CODE (DTC)

Engine (Diagnostics)

● WIRING DIAGRAM:

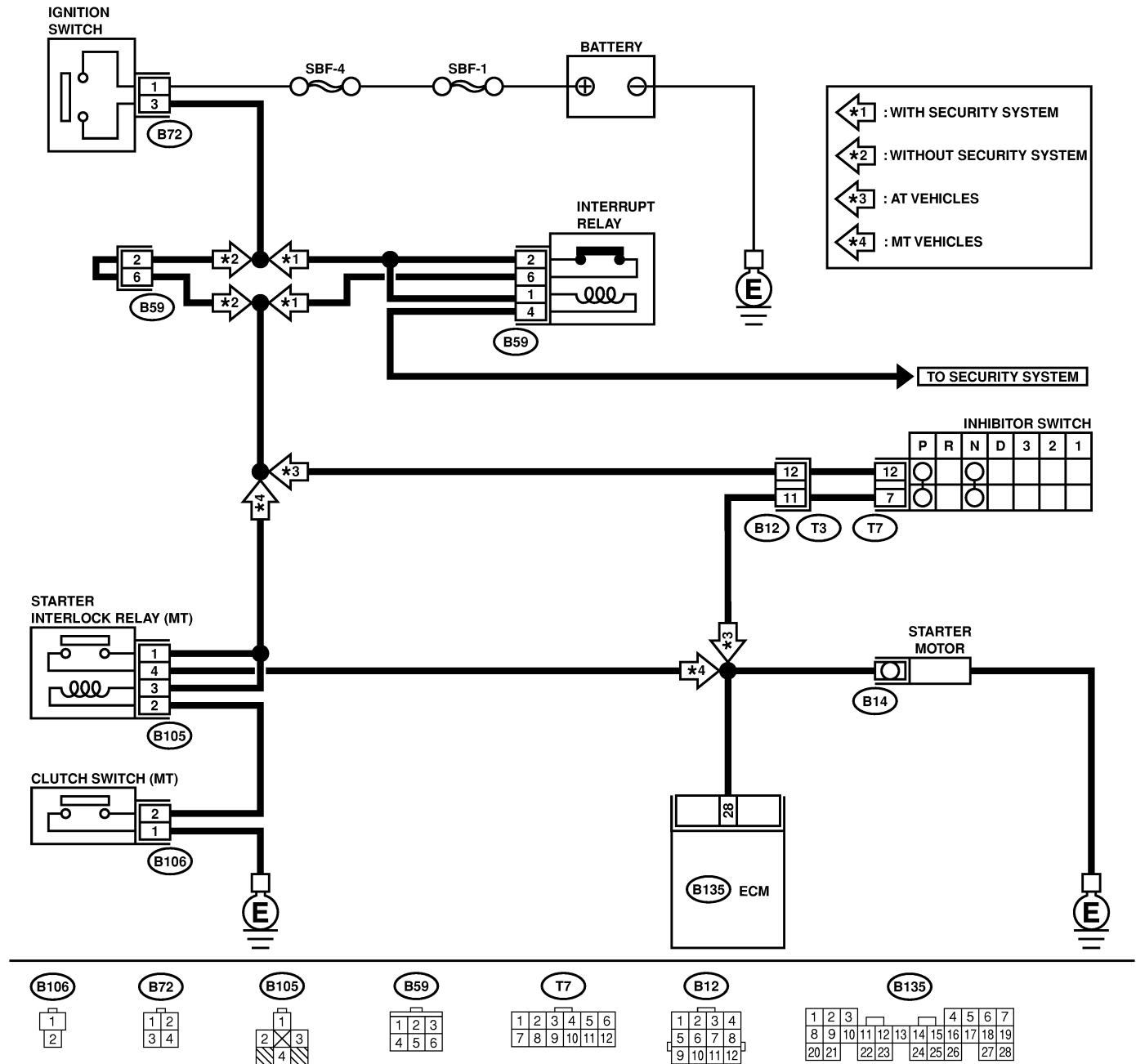

B2M4635

DIAGNOSTIC PROCEDURE WITH DIAGNOSTIC TROUBLE CODE (DTC)

Engine (Diagnostics)

No.	Step	Check	Yes	No
1	CHECK OPERATION OF STARTER MOTOR. NOTE: Place the inhibitor switch in the "P" or "N" position.	Does starter motor operate when ignition switch to "ST"?	Repair harness and connector. NOTE: In this case, repair the following: <ul style="list-style-type: none">● Open or ground short circuit in harness between ECM and starter motor connector.● Poor contact in ECM connector.	Check starter motor circuit. <Ref. to EN-70, STARTER MOTOR CIRCUIT, Diagnostic for Engine Starting Failure.>

MEMO:

DIAGNOSTIC PROCEDURE WITH DIAGNOSTIC TROUBLE CODE (DTC)

Engine (Diagnostics)

CW: DTC P1540 — VEHICLE SPEED SENSOR MALFUNCTION 2 — S078521C26

- **DTC DETECTING CONDITION:**
 - Immediately at fault recognition

CAUTION:

After repair or replacement of faulty parts, conduct Clear Memory Mode <Ref. to EN-55, OPERATION, Clear Memory Mode.> and Inspection Mode <Ref. to EN-48, OPERATION, Inspection Mode.>.

- **WIRING DIAGRAM:**

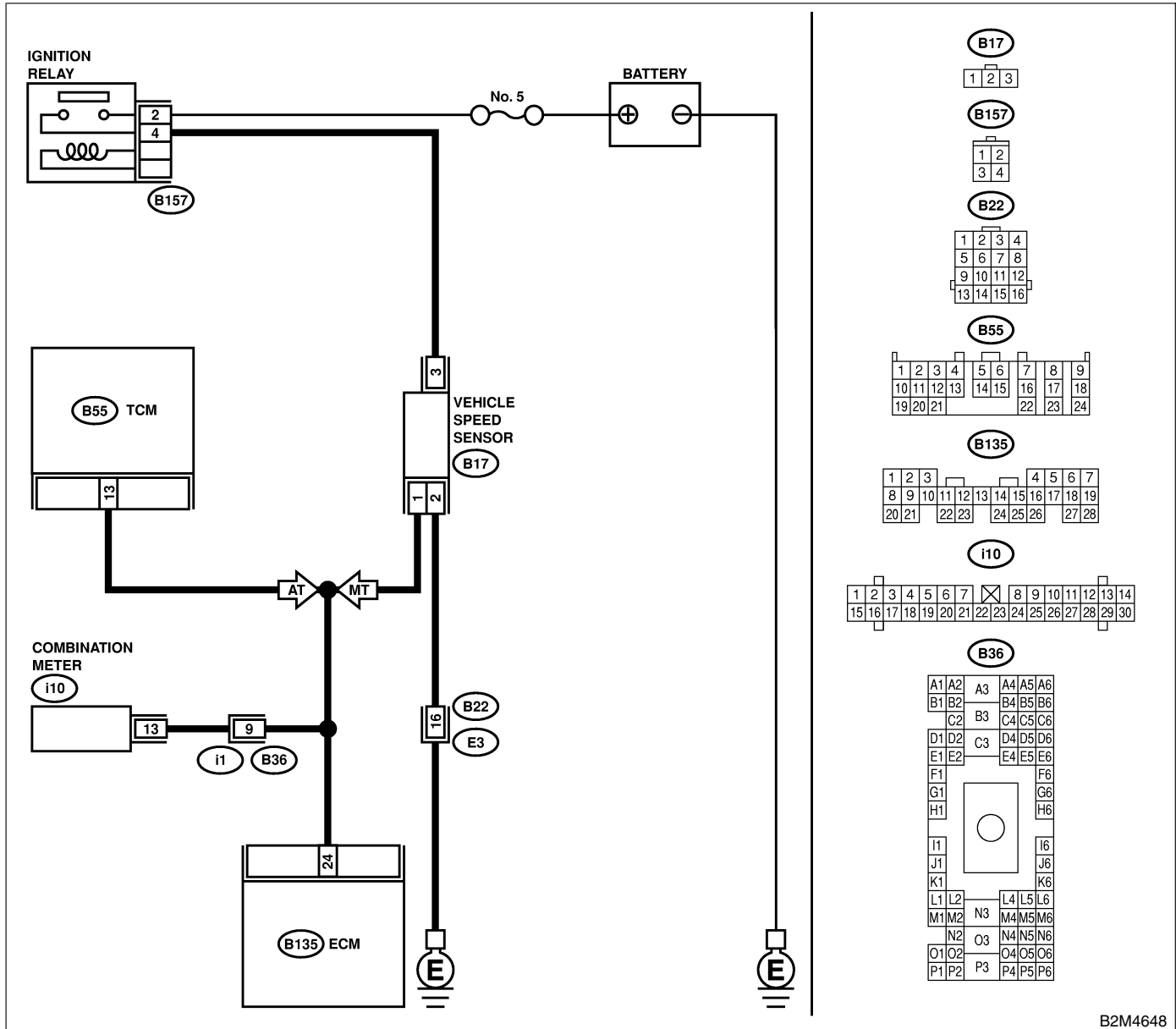

B2M4648

DIAGNOSTIC PROCEDURE WITH DIAGNOSTIC TROUBLE CODE (DTC)

Engine (Diagnostics)

No.	Step	Check	Yes	No
1	CHECK DTC P0720 ON DISPLAY.	Does the Subaru Select Monitor or OBD-II general scan tool indicate DTC P0720?	Check front vehicle speed sensor signal circuit. <Ref. to AT-60, DTC 33 FRONT VEHICLE SPEED SENSOR, Diagnostic Procedure with Trouble Code (DTC).>	Go to step 2.
2	CHECK SPEEDOMETER OPERATION IN COMBINATION METER.	Does speedometer operate normally?	Go to step 3.	Check speedometer and vehicle speed sensor. <Ref. to IDI-13, Speedometer.>
3	CHECK HARNESS BETWEEN ECM AND COMBINATION METER CONNECTOR. 1) Turn ignition switch to OFF. 2) Disconnect connector from combination meter. 3) Measure resistance between ECM and combination meter. Connector & terminal (B135) No. 24 — (I10) No. 13:	Is the resistance less than 10 Ω?	Repair poor contact in ECM connector.	Repair harness and connector. NOTE: In this case, repair the following: <ul style="list-style-type: none"> ● Open circuit in harness between ECM and combination meter connector ● Poor contact in ECM connector ● Poor contact in combination meter connector ● Poor contact in coupling connector

DIAGNOSTIC PROCEDURE WITH DIAGNOSTIC TROUBLE CODE (DTC)

Engine (Diagnostics)

CX: DTC P1560 — BACK-UP VOLTAGE CIRCUIT MALFUNCTION — S078521C27

- **DTC DETECTING CONDITION:**
 - Immediately at fault recognition

CAUTION:

After repair or replacement of faulty parts, conduct Clear Memory Mode <Ref. to EN-55, OPERATION, Clear Memory Mode.> and Inspection Mode <Ref. to EN-48, OPERATION, Inspection Mode.>.

- **WIRING DIAGRAM:**

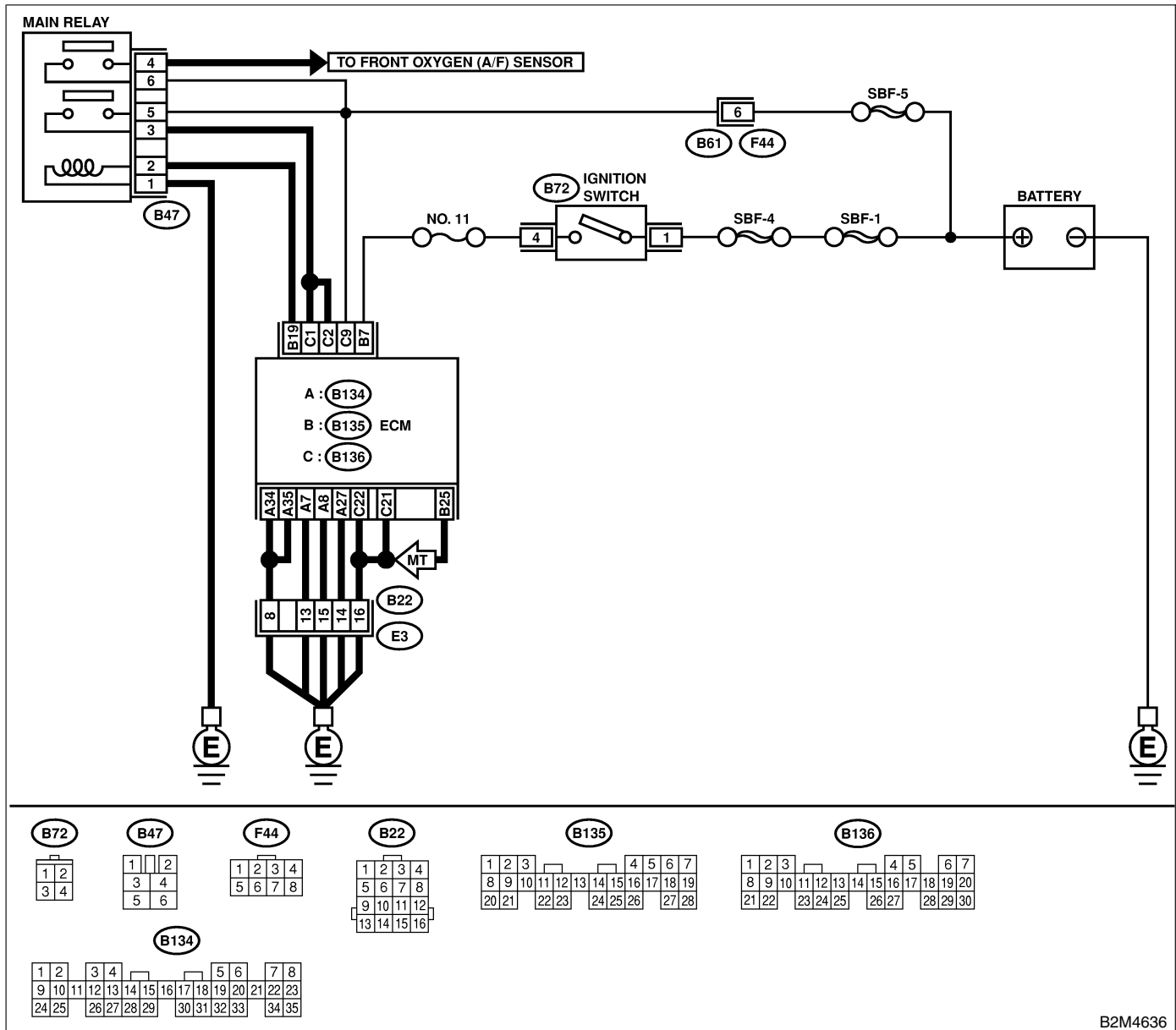

B2M4636

No.	Step	Check	Yes	No
1	CHECK INPUT SIGNAL FOR ECM. 1) Turn ignition switch to OFF. 2) Measure voltage between ECM and chassis ground. <i>Connector & terminal</i> <i>(B136) No. 9 (+) — Chassis ground (-):</i>	Is the voltage more than 10 V?	Repair poor contact in ECM connector.	Go to step 2.

DIAGNOSTIC PROCEDURE WITH DIAGNOSTIC TROUBLE CODE (DTC)

Engine (Diagnostics)

No.	Step	Check	Yes	No
2	CHECK HARNESS BETWEEN ECM AND MAIN FUSE BOX CONNECTOR. 1) Disconnect connector from ECM. 2) Measure resistance of harness between ECM and chassis ground. <i>Connector & terminal (B136) No. 9 — Chassis ground:</i>	Is the resistance less than 10 Ω ?	Repair ground short circuit in harness between ECM connector and battery terminal.	Go to step 3.
3	CHECK FUSE SBF-5.	Is fuse blown?	Replace fuse.	Repair harness and connector. NOTE: In this case, repair the following: ● Open circuit in harness between ECM and battery ● Poor contact in ECM connector ● Poor contact in battery terminal

DIAGNOSTIC PROCEDURE WITH DIAGNOSTIC TROUBLE CODE (DTC)

Engine (Diagnostics)

CY: DTC P1698 — ENGINE TORQUE CONTROL CUT SIGNAL CIRCUIT LOW INPUT — S078521G15

● DTC DETECTING CONDITION:

- Two consecutive driving cycles with fault

CAUTION:

After repair or replacement of faulty parts, conduct Clear Memory Mode <Ref. to EN-55, OPERATION, Clear Memory Mode.> and Inspection Mode <Ref. to EN-48, OPERATION, Inspection Mode.>.

● WIRING DIAGRAM:

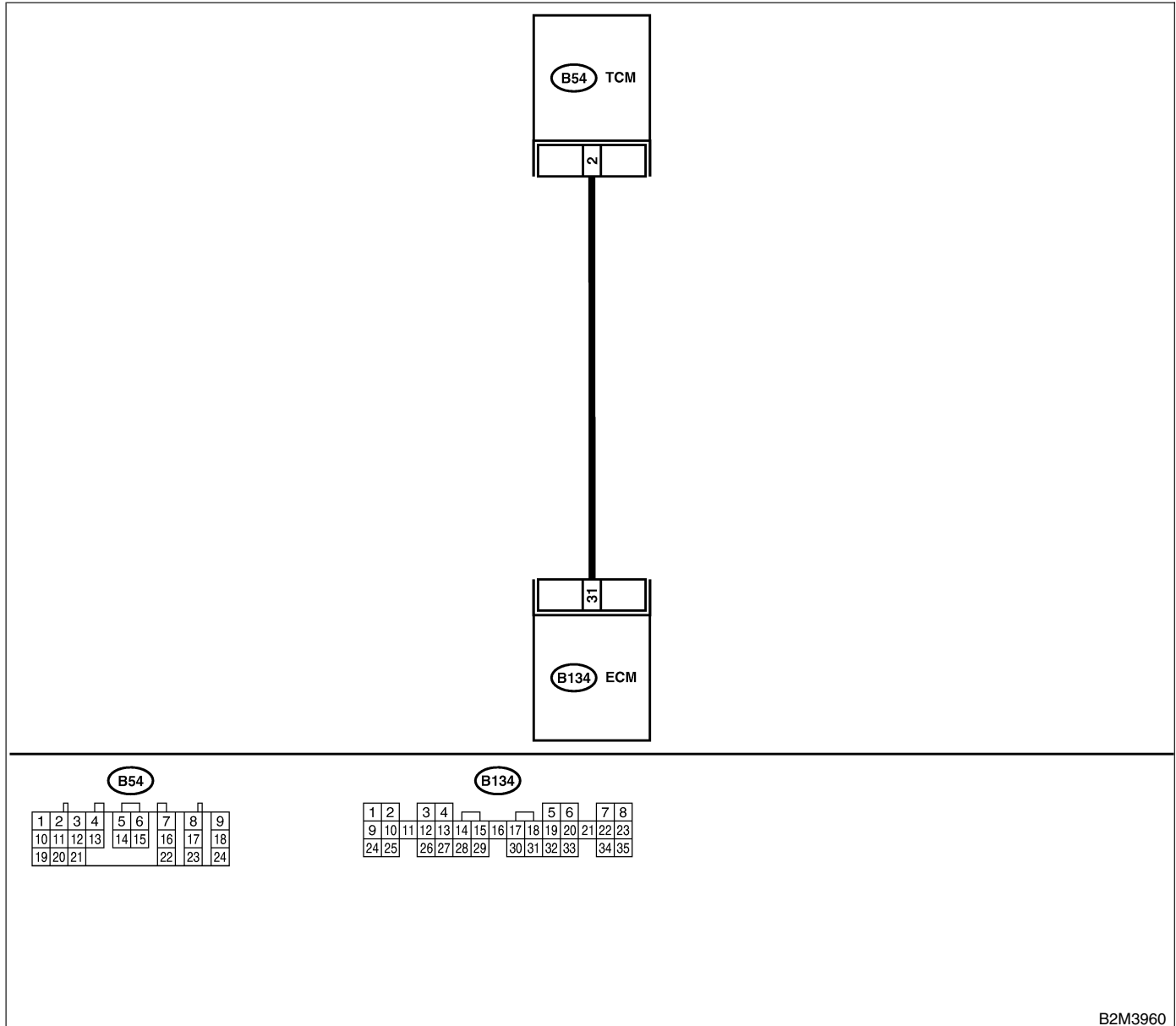

B2M3960

DIAGNOSTIC PROCEDURE WITH DIAGNOSTIC TROUBLE CODE (DTC)

Engine (Diagnostics)

No.	Step	Check	Yes	No
1	CHECK OUTPUT SIGNAL FROM ECM. 1) Start engine, and warm-up the engine. 2) Turn ignition switch to OFF. 3) Turn ignition switch to ON. 4) Measure voltage between ECM and chassis ground. Connector & terminal (B134) No. 31 (+) — Chassis ground (-):	Is the voltage more than 3 V?	Repair poor contact in ECM connector.	Go to step 2.
2	CHECK HARNESS BETWEEN ECM AND TCM CONNECTOR. 1) Turn ignition switch to OFF. 2) Disconnect connectors from ECM and TCM. 3) Measure resistance of harness between ECM and chassis ground. Connector & terminal (B134) No. 31 — Chassis ground:	Is the resistance less than 10 Ω ?	Repair ground short circuit in harness between ECM and TCM connector.	Go to step 3.
3	CHECK HARNESS BETWEEN ECM AND TCM CONNECTOR. Measure resistance of harness between ECM and TCM connector. Connector & terminal (B134) No. 31 — (B54) No. 2:	Is the resistance less than 1 Ω ?	Repair poor contact in ECM or TCM connector.	Repair open circuit in harness between ECM and TCM connector.

DIAGNOSTIC PROCEDURE WITH DIAGNOSTIC TROUBLE CODE (DTC)

Engine (Diagnostics)

CZ: DTC P1699 — ENGINE TORQUE CONTROL CUT SIGNAL CIRCUIT HIGH INPUT — S078521G16

● DTC DETECTING CONDITION:

- Two consecutive driving cycles with fault

CAUTION:

After repair or replacement of faulty parts, conduct Clear Memory Mode <Ref. to EN-55, OPERATION, Clear Memory Mode.> and Inspection Mode <Ref. to EN-48, OPERATION, Inspection Mode.>.

● WIRING DIAGRAM:

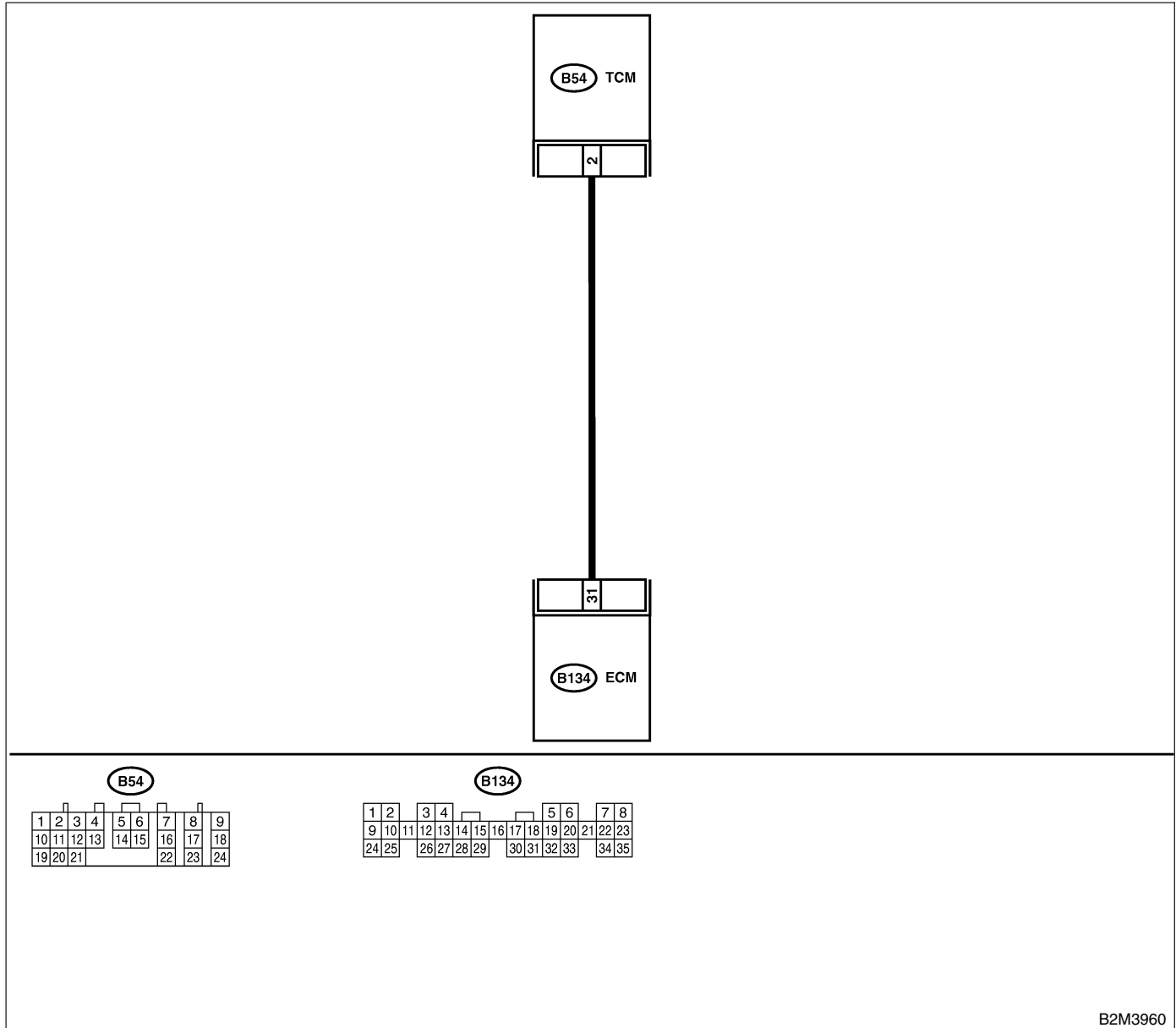

B2M3960

DIAGNOSTIC PROCEDURE WITH DIAGNOSTIC TROUBLE CODE (DTC)

Engine (Diagnostics)

No.	Step	Check	Yes	No
1	<p>CHECK OUTPUT SIGNAL FROM ECM.</p> <p>1) Start engine, and warm-up the engine. 2) Turn ignition switch to OFF. 3) Disconnect connector from TCM. 4) Turn ignition switch to ON. 5) Measure voltage between ECM and chassis ground.</p> <p>Connector & terminal (B134) No. 31 (+) — Chassis ground (-):</p>	Is the voltage less than 3 V?	Go to step 2.	Repair battery short circuit in harness between ECM and TCM connector. After repair, replace ECM. <Ref. to FU-51, Engine Control Module.>
2	<p>CHECK HARNESS BETWEEN ECM AND TCM CONNECTOR.</p> <p>1) Turn ignition switch to OFF. 2) Measure voltage between ECM and chassis ground.</p> <p>Connector & terminal (B134) No. 31 (+) — Chassis ground (-):</p>	Does the voltage change more than 10 V by shaking harness and connector of ECM while monitoring the value with voltage meter?	Repair battery short circuit in harness between ECM and TCM connector. After repair, replace ECM. <Ref. to FU-51, Engine Control Module.>	Contact with SOA (distributor) service. NOTE: Inspection by DTM is required, because probable cause is deterioration of multiple parts.

DIAGNOSTIC PROCEDURE WITH DIAGNOSTIC TROUBLE CODE (DTC)

Engine (Diagnostics)

DA: DTC P1701 — CRUISE CONTROL SET SIGNAL CIRCUIT MALFUNCTION FOR AUTOMATIC TRANSMISSION — S078521C29

● DTC DETECTING CONDITION:

- Two consecutive driving cycles with fault

CAUTION:

After repair or replacement of faulty parts, conduct Clear Memory Mode <Ref. to EN-55, OPERATION, Clear Memory Mode.> and Inspection Mode <Ref. to EN-48, OPERATION, Inspection Mode.>.

● WIRING DIAGRAM:

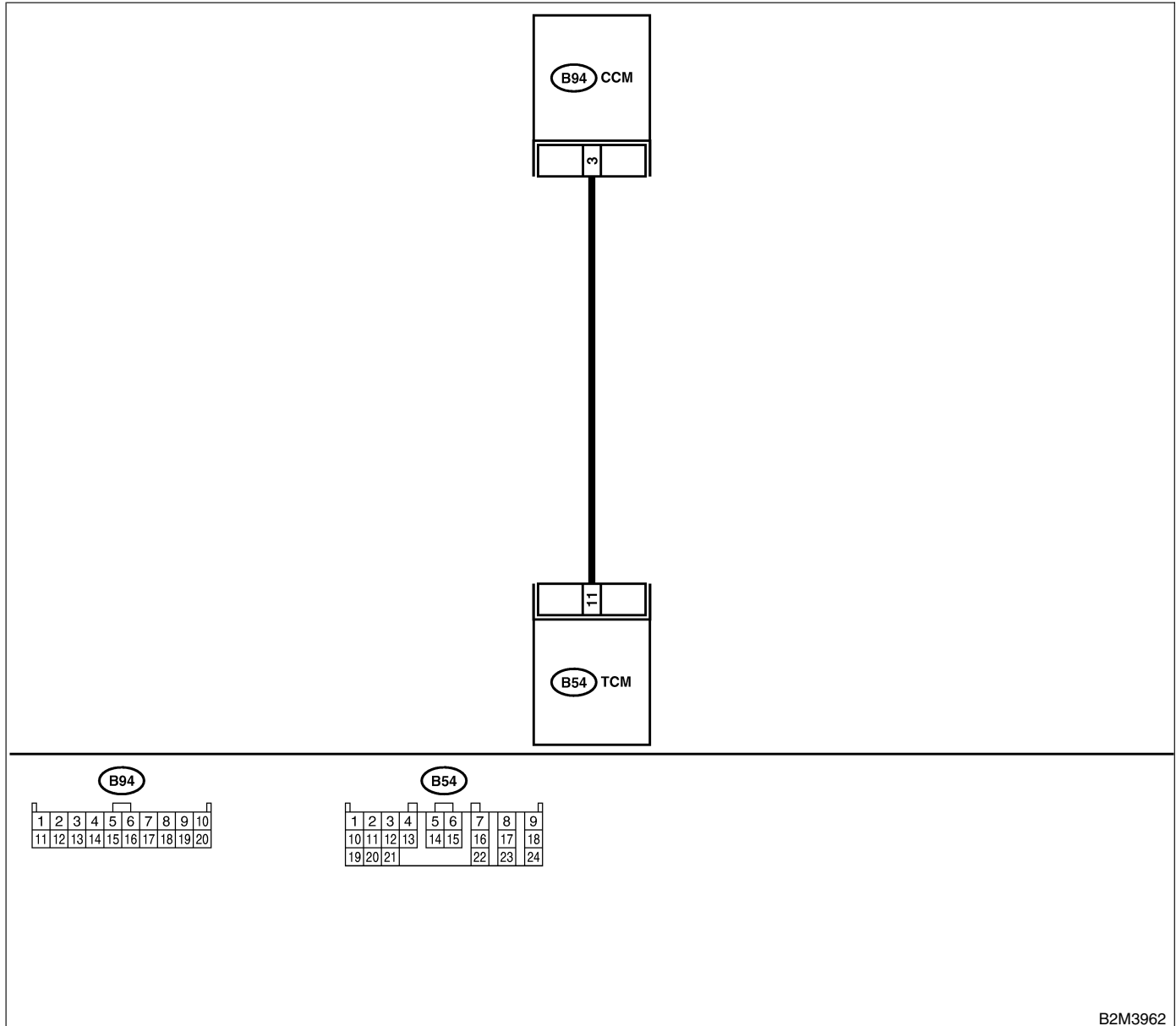

B2M3962

DIAGNOSTIC PROCEDURE WITH DIAGNOSTIC TROUBLE CODE (DTC)

Engine (Diagnostics)

No.	Step	Check	Yes	No
1	<p>CHECK HARNESS BETWEEN TCM AND CCM CONNECTOR.</p> <p>1) Turn ignition switch to OFF. 2) Disconnect connectors from TCM and CCM. 3) Measure resistance of harness between TCM and CCM connector.</p> <p>Connector & terminal (B54) No. 11 — (B94) No. 3:</p>	Is the resistance less than 1 Ω?	Go to step 2.	Repair open circuit in harness between TCM and CCM connector.
2	<p>CHECK HARNESS BETWEEN TCM AND CCM CONNECTOR.</p> <p>Measure resistance of harness between TCM and chassis ground.</p> <p>Connector & terminal (B54) No. 11 — Chassis ground:</p>	Is the resistance less than 10 Ω?	Repair short circuit in harness between TCM and CCM connector.	Go to step 3.
3	<p>CHECK INPUT SIGNAL FOR TCM.</p> <p>1) Connect connector to TCM and CCM. 2) Lift-up the vehicle or set the vehicle on free rollers.</p> <p>CAUTION: On AWD models, raise all wheels off ground.</p> <p>3) Start the engine. 4) Cruise control main switch to ON. 5) Move selector lever to “D” and slowly increase vehicle speed to 50 km/h (31 MPH). 6) Cruise control command switch to ON. 7) Measure voltage between TCM and chassis ground.</p> <p>Connector & terminal (B54) No. 11 (+) — Chassis ground (-):</p>	Is the resistance less than 1 V?	Go to step 4.	Check cruise control command switch circuit. <Ref. to CC-6, INSPECTION, Cruise Control Command Switch.>
4	<p>CHECK POOR CONTACT.</p> <p>Check poor contact in TCM connector.</p>	Is there poor contact in TCM connector?	Repair poor contact in TCM connector.	Replace TCM. <Ref. to AT-49, Transmission Control Module (TCM).>

DIAGNOSTIC PROCEDURE WITH DIAGNOSTIC TROUBLE CODE (DTC)

Engine (Diagnostics)

DB: DTC P1711 — ENGINE TORQUE CONTROL SIGNAL 1 CIRCUIT MALFUNCTION — S078521G17

● DTC DETECTING CONDITION:

- Two consecutive driving cycles with fault

● TROUBLE SYMPTOM:

- Excessive shift shock

CAUTION:

After repair or replacement of faulty parts, conduct Clear Memory Mode <Ref. to EN-55, OPERATION, Clear Memory Mode.> and Inspection Mode <Ref. to EN-48, OPERATION, Inspection Mode.>.

● WIRING DIAGRAM:

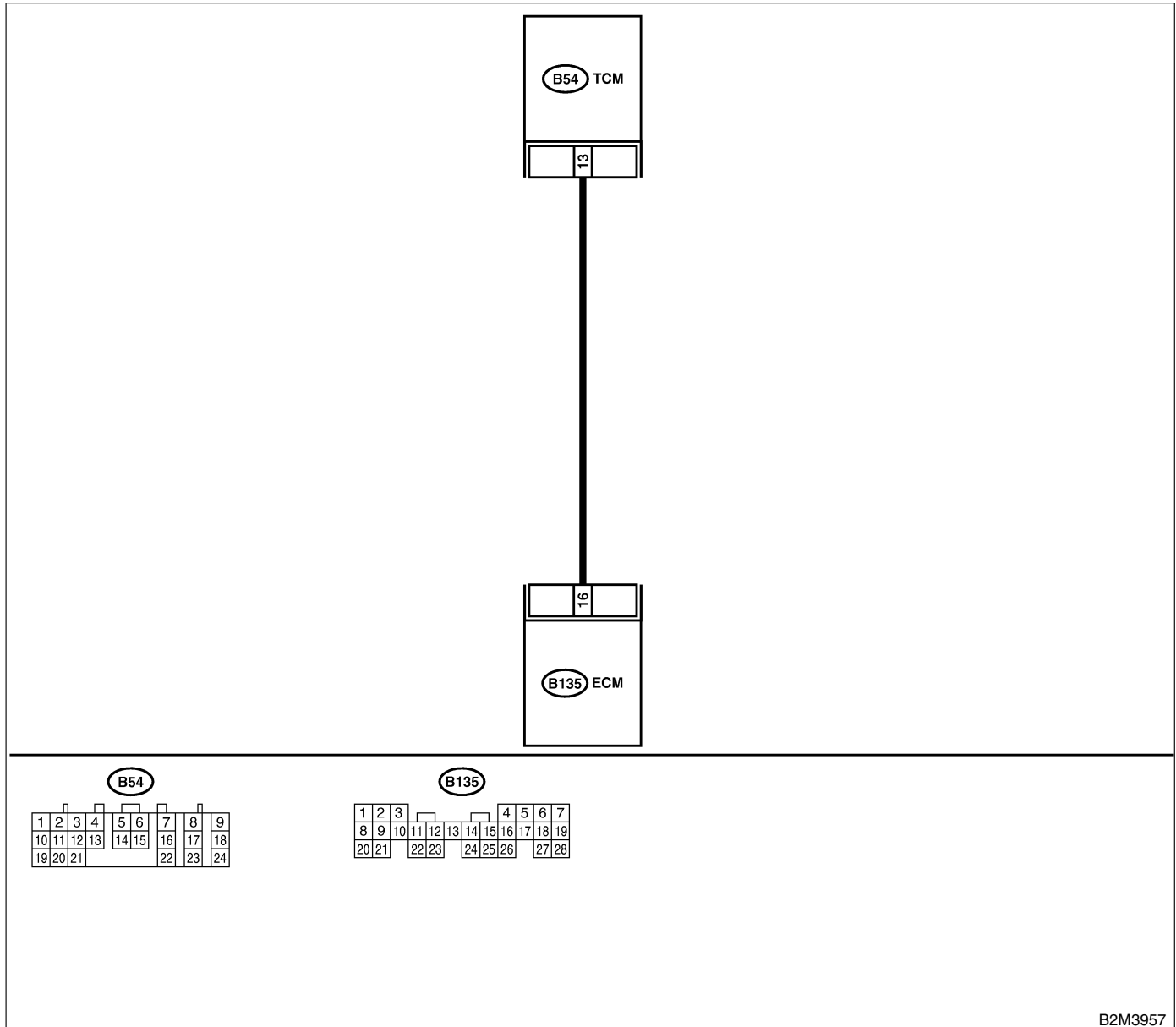

B2M3957

DIAGNOSTIC PROCEDURE WITH DIAGNOSTIC TROUBLE CODE (DTC)

Engine (Diagnostics)

No.	Step	Check	Yes	No
1	CHECK INPUT SIGNAL FOR ECM. 1) Turn ignition switch to ON. 2) Measure voltage between ECM and chassis ground. <i>Connector & terminal</i> <i>(B135) No. 16 (+) — Chassis ground (-):</i>	Is the voltage more than 4.5 V?	Go to step 2.	Go to step 4.
2	CHECK INPUT SIGNAL FOR ECM. Measure voltage between ECM and chassis ground. <i>Connector & terminal</i> <i>(B135) No. 16 (+) — Chassis ground (-):</i>	Is the voltage more than 10 V?	Repair battery short circuit in harness between ECM and TCM connector.	Go to step 3.
3	CHECK POOR CONTACT. Check poor contact in ECM connector.	Is there poor contact in ECM connector?	Repair poor contact in ECM connector.	Contact with SOA (distributor) service. NOTE: Inspection by DTM is required, because probable cause is deterioration of multiple parts.
4	CHECK HARNESS BETWEEN ECM AND TCM CONNECTOR. 1) Turn ignition switch to OFF. 2) Disconnect connectors from ECM and TCM. 3) Measure resistance of harness between ECM and TCM connector. <i>Connector & terminal</i> <i>(B135) No. 16 — (B54) No. 13:</i>	Is the resistance less than 1 Ω ?	Go to step 5.	Repair open circuit in harness between ECM and TCM connector.
5	CHECK HARNESS BETWEEN ECM AND TCM CONNECTOR. Measure resistance of harness between ECM and chassis ground. <i>Connector & terminal</i> <i>(B135) No. 16 — Chassis ground:</i>	Is the resistance less than 10 Ω ?	Repair ground short circuit in harness between ECM and TCM connector.	Go to step 6.
6	CHECK POOR CONTACT. Check poor contact in TCM connector.	Is there poor contact in TCM connector?	Repair poor contact in TCM connector.	Replace TCM. <Ref. to AT-49, Transmission Control Module (TCM).>

DIAGNOSTIC PROCEDURE WITH DIAGNOSTIC TROUBLE CODE (DTC)

Engine (Diagnostics)

DC: DTC P1712 — ENGINE TORQUE CONTROL SIGNAL 2 CIRCUIT MALFUNCTION — S078521G18

● DTC DETECTING CONDITION:

- Two consecutive driving cycles with fault

● TROUBLE SYMPTOM:

- Excessive shift shock

CAUTION:

After repair or replacement of faulty parts, conduct Clear Memory Mode <Ref. to EN-55, OPERATION, Clear Memory Mode.> and Inspection Mode <Ref. to EN-48, OPERATION, Inspection Mode.>.

● WIRING DIAGRAM:

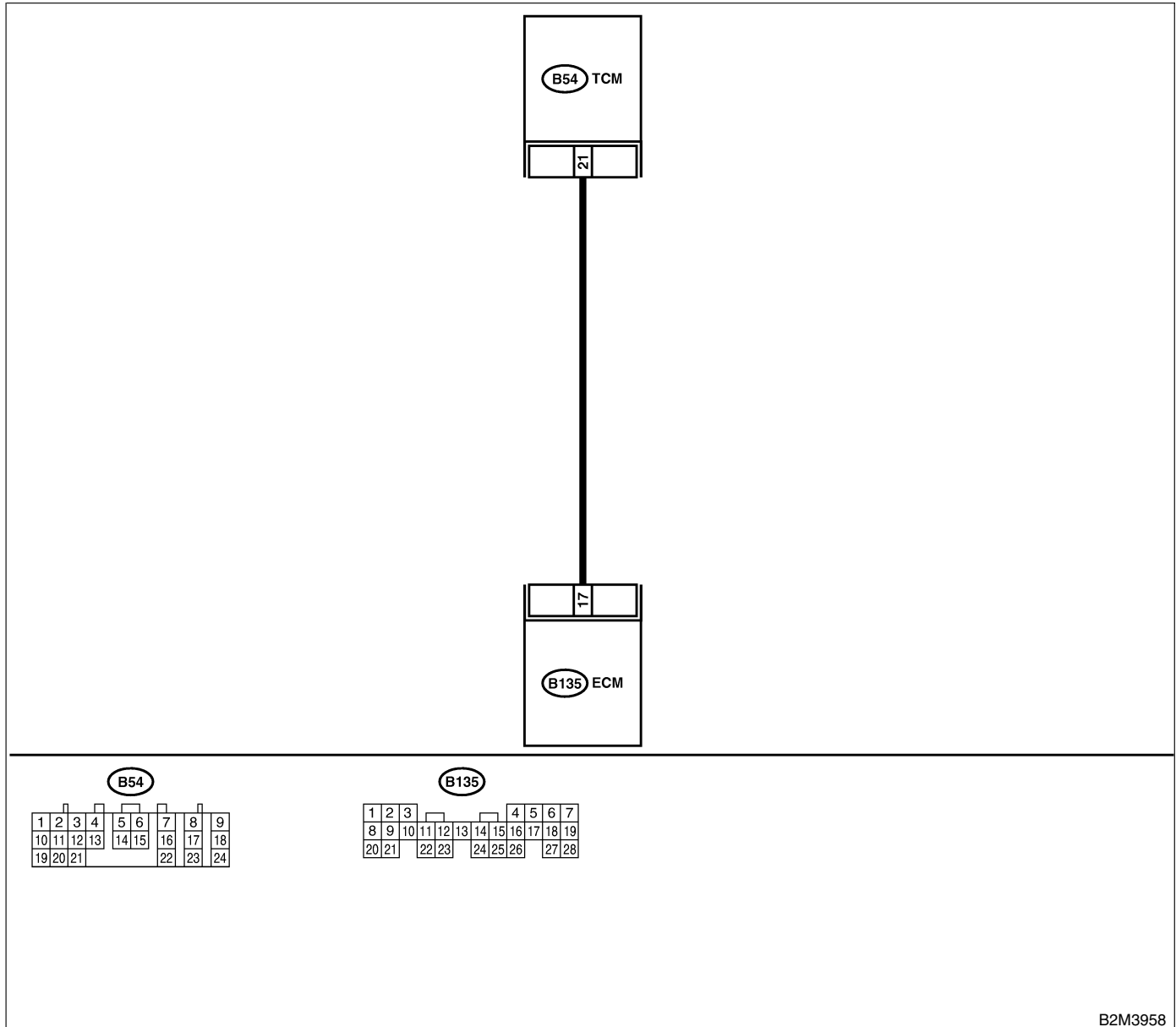

B2M3958

DIAGNOSTIC PROCEDURE WITH DIAGNOSTIC TROUBLE CODE (DTC)

Engine (Diagnostics)

No.	Step	Check	Yes	No
1	CHECK INPUT SIGNAL FOR ECM. 1) Turn ignition switch to ON. 2) Measure voltage between ECM and chassis ground. <i>Connector & terminal</i> <i>(B135) No. 17 (+) — Chassis ground (-):</i>	Is the voltage more than 4.5 V?	Go to step 2.	Go to step 4.
2	CHECK INPUT SIGNAL FOR ECM. Measure voltage between ECM and chassis ground. <i>Connector & terminal</i> <i>(B135) No. 17 (+) — Chassis ground (-):</i>	Is the voltage more than 10 V?	Repair battery short circuit in harness between ECM and TCM connector.	Go to step 3.
3	CHECK POOR CONTACT. Check poor contact in ECM connector.	Is there poor contact in ECM connector?	Repair poor contact in ECM connector.	Contact with SOA (distributor) service. NOTE: Inspection by DTM is required, because probable cause is deterioration of multiple parts.
4	CHECK HARNESS BETWEEN ECM AND TCM CONNECTOR. 1) Turn ignition switch to OFF. 2) Disconnect connectors from ECM and TCM. 3) Measure resistance of harness between ECM and TCM connector. <i>Connector & terminal</i> <i>(B135) No. 17 — (B54) No. 21:</i>	Is the resistance less than 1 Ω ?	Go to step 5.	Repair open circuit in harness between ECM and TCM connector.
5	CHECK HARNESS BETWEEN ECM AND TCM CONNECTOR. Measure resistance of harness between ECM and chassis ground. <i>Connector & terminal</i> <i>(B135) No. 17 — Chassis ground:</i>	Is the resistance less than 10 Ω ?	Repair ground short circuit in harness between ECM and TCM connector.	Go to step 6.
6	CHECK POOR CONTACT. Check poor contact in TCM connector.	Is there poor contact in TCM connector?	Repair poor contact in TCM connector.	Replace TCM. <Ref. to AT-49, Transmission Control Module (TCM).>