

3. Intake Manifold S175034

A: REMOVAL S175034A18

- 1) Release fuel pressure. <Ref. to FU-54, RELEASING OF FUEL PRESSURE, OPERATION, Fuel.>
- 2) Open fuel flap lid, and remove fuel filler cap.

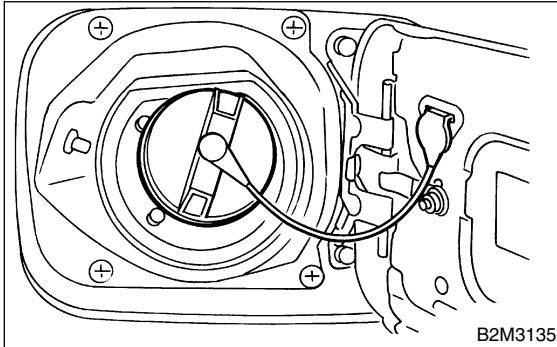

- 3) Disconnect battery ground cable.

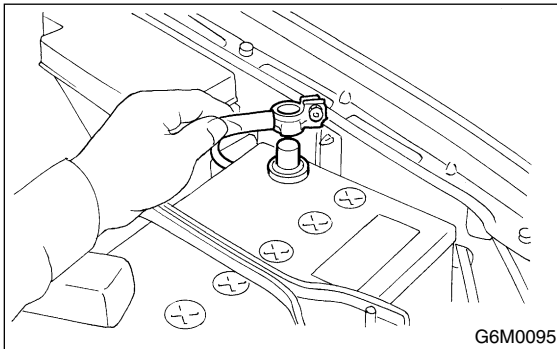

- 4) Remove air intake duct and air cleaner case. <Ref. to IN-7, REMOVAL, Air Intake Duct.> and <Ref. to IN-6, REMOVAL, Air Cleaner Case.>
- 5) Disconnect accelerator cable (A).
- 6) Disconnect cruise control cable (B). (With cruise control model)

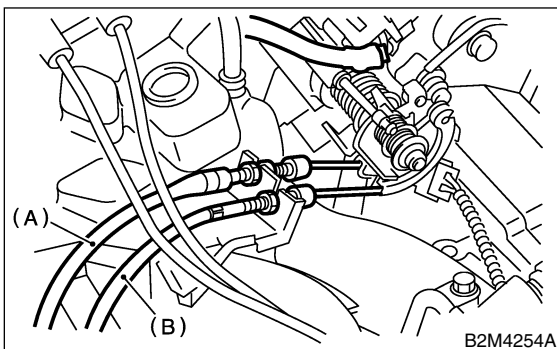

- 7) Remove power steering pump and tank from brackets.

- (1) Remove resonator chamber.

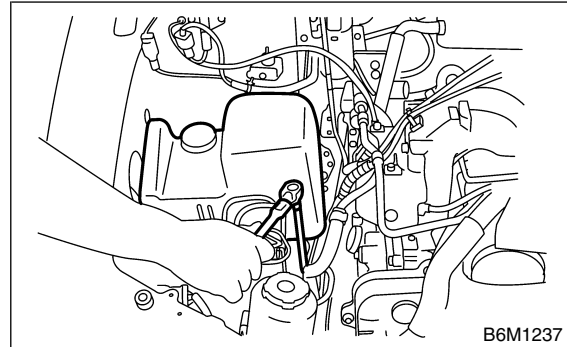

- (2) Remove V-belt covers.

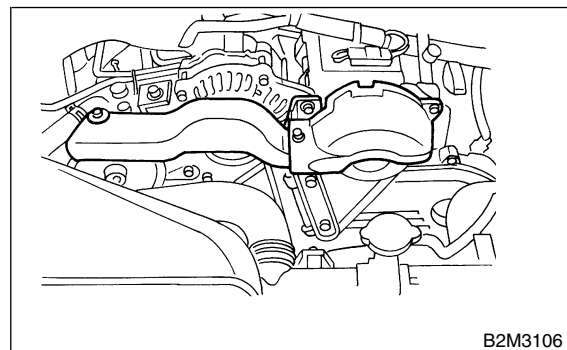

- (3) Loosen lock bolt and slider bolt, and remove power steering pump drive V-belt.

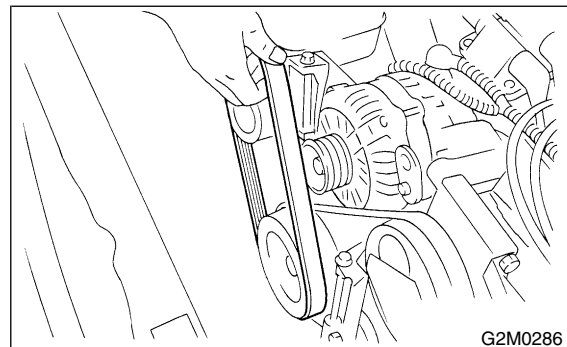

INTAKE MANIFOLD

Fuel Injection (Fuel Systems)

(4) Remove bolts which hold power steering pipes onto intake manifold protector.

NOTE:

Do not disconnect power steering hose.

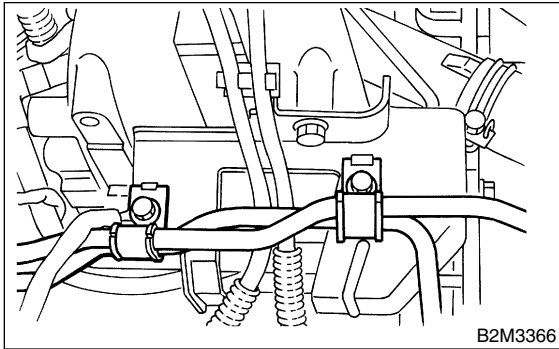

(5) Remove bolts which install power steering pump bracket.

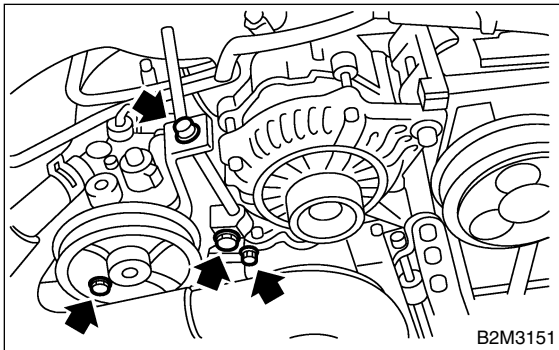

(6) Disconnect connector from power steering pump switch.

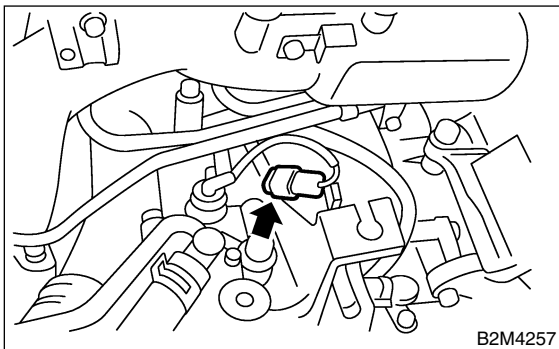

(7) Remove power steering tank from the bracket by pulling it upwards.

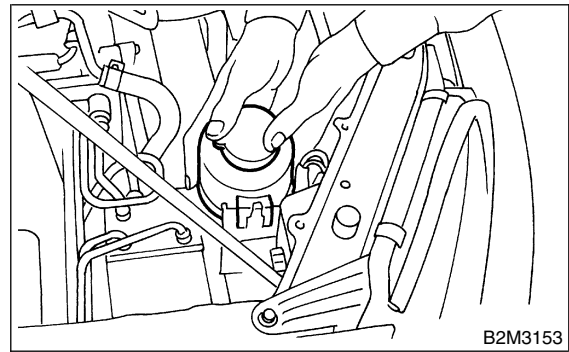

(8) Place power steering pump and tank on the right side wheel apron.

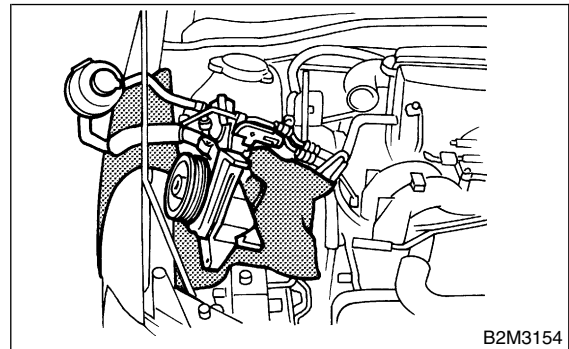

8) Disconnect spark plug cords from spark plugs.
9) Disconnect PCV hose from intake manifold.

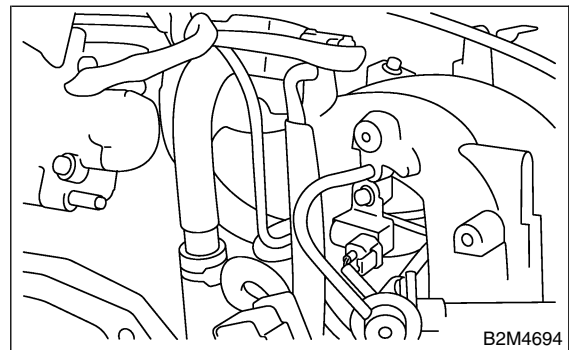

10) Disconnect engine coolant hose from throttle body.

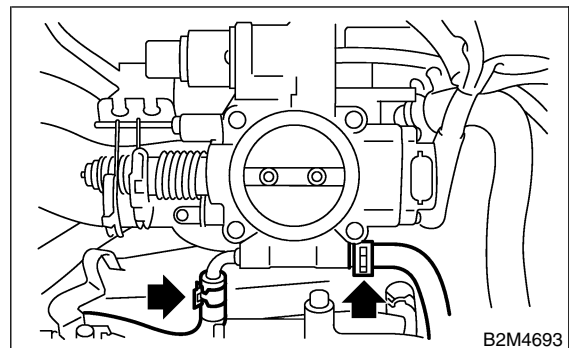

INTAKE MANIFOLD

Fuel Injection (Fuel Systems)

- 11) Disconnect brake booster hose.

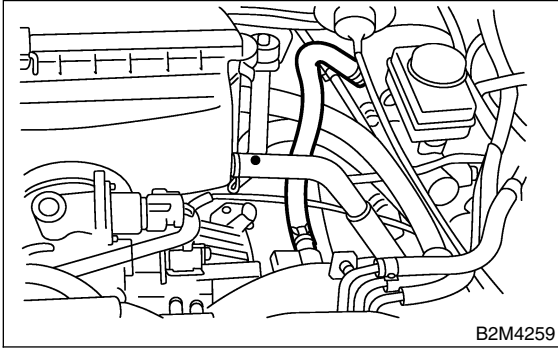

- 12) Remove air cleaner case stay RH and engine harness bracket, and disconnect engine harness connectors from bulkhead harness connectors.



- 13) Disconnect connectors from engine coolant temperature sensor.

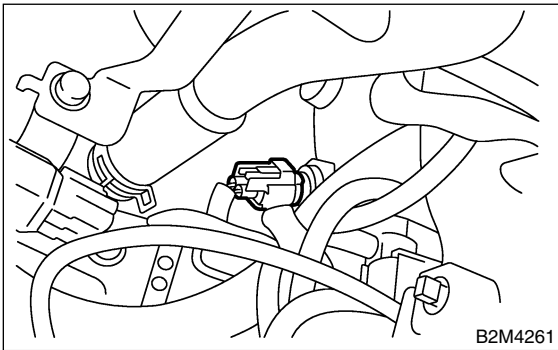

- 14) Disconnect knock sensor connector.

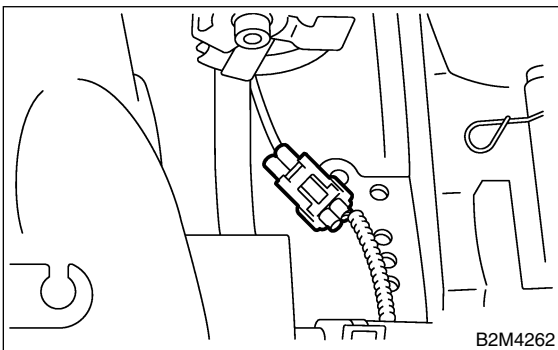

- 15) Disconnect connector from crankshaft position sensor.

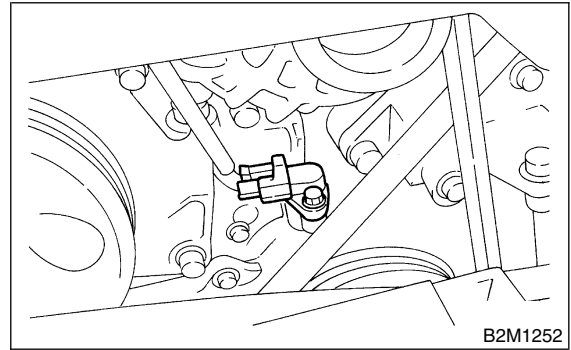

- 16) Disconnect connector from oil pressure switch.

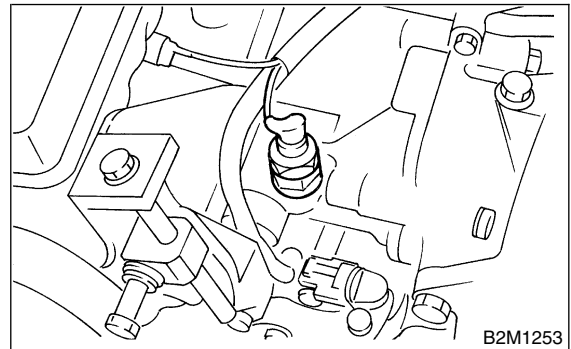

- 17) Disconnect connector from camshaft position sensor.

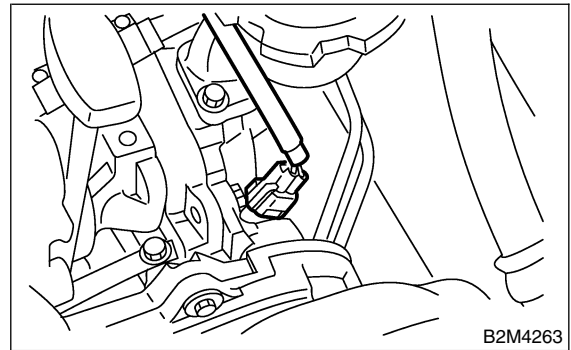

INTAKE MANIFOLD

Fuel Injection (Fuel Systems)

18) Disconnect fuel hoses from fuel pipes.

WARNING:

- Do not spill fuel.
- Catch fuel from hoses in a container or cloth.

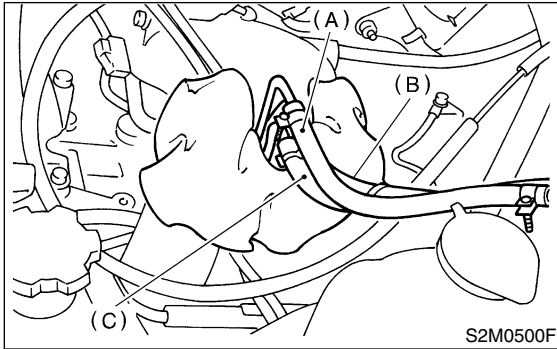

- (A) Fuel delivery hose
- (B) Return hose
- (C) Evaporation hose

19) Remove bolts which hold intake manifold onto cylinder heads.

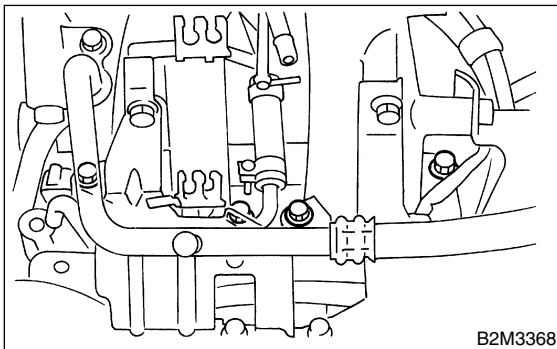

20) Remove intake manifold.

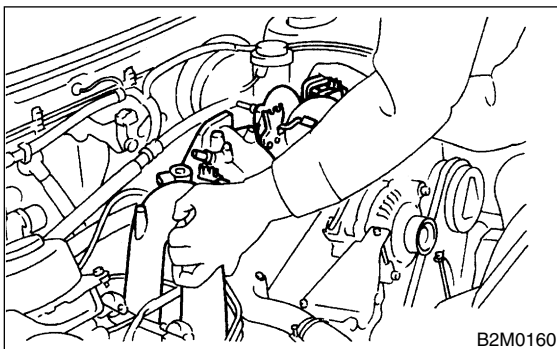

B: INSTALLATION S175034A11

1) Install intake manifold onto cylinder heads.

NOTE:

Always use new gaskets.

Tightening torque:

25 N·m (2.5 kgf·m, 18.1 ft·lb)

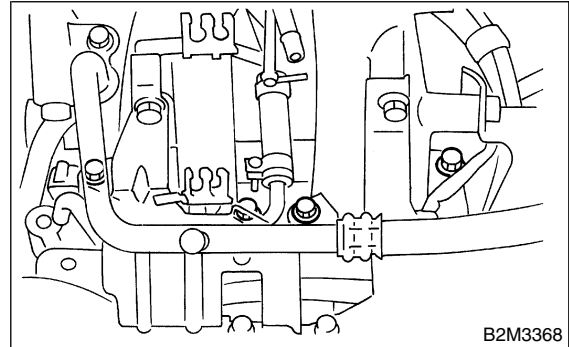

2) Connect fuel hoses.

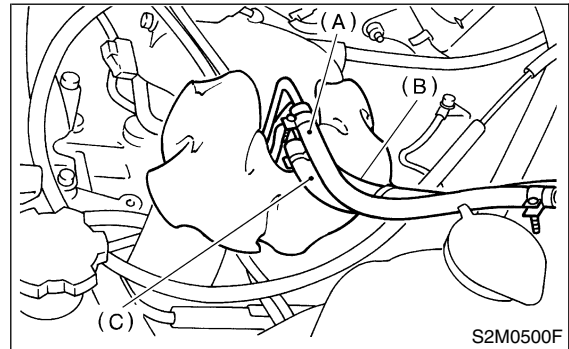

- (A) Fuel delivery hose
- (B) Return hose
- (C) Evaporation hose

3) Connect connector to camshaft position sensor.

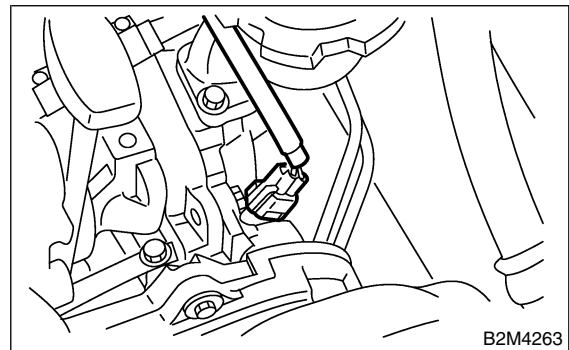

INTAKE MANIFOLD

Fuel Injection (Fuel Systems)

- 4) Connect connector to oil pressure switch.

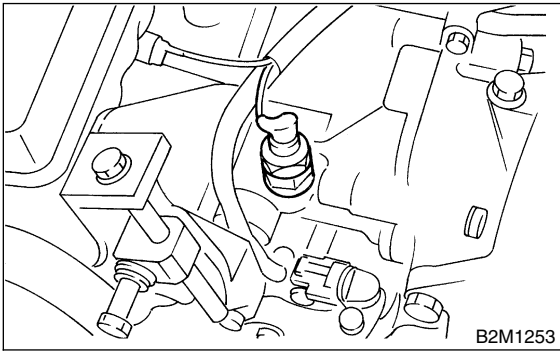

- 5) Connect connector to crankshaft position sensor.

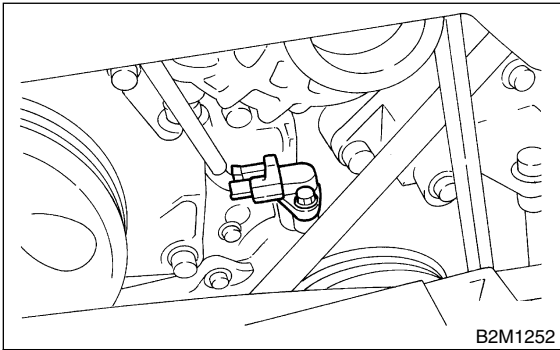

- 6) Connect knock sensor connector.

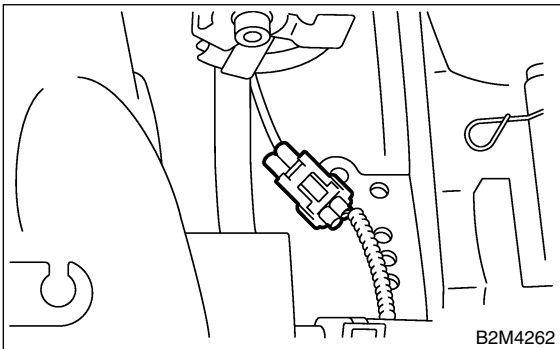

- 7) Connect connectors to engine coolant temperature sensor.

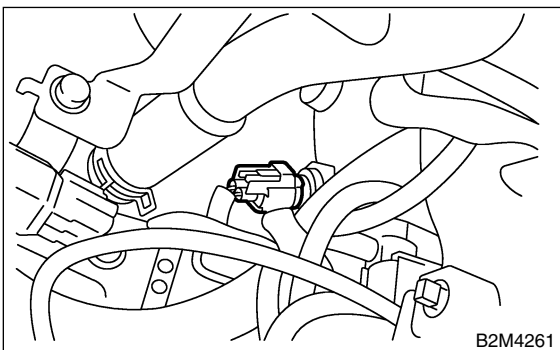

- 8) Install air cleaner case stay RH and engine harness bracket, and connect engine harness connectors to bulkhead connectors.



- 9) Connect brake booster hose.

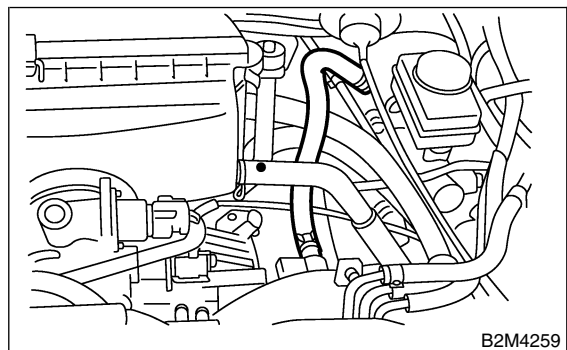

- 10) Connect engine coolant hose to throttle body.

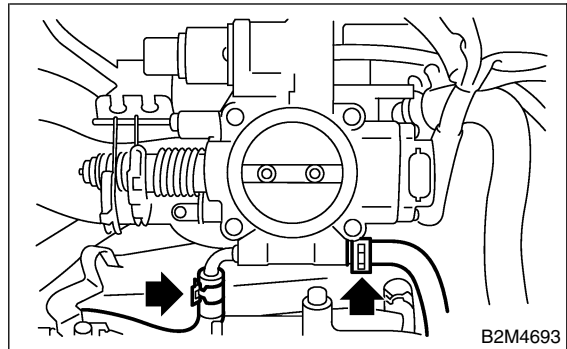

- 11) Connect PCV hose to intake manifold.

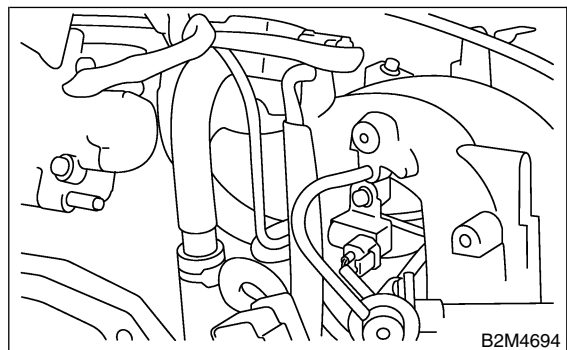

- 12) Connect spark plug cords to spark plugs.

INTAKE MANIFOLD

Fuel Injection (Fuel Systems)

13) Install power steering pump and tank on brackets.

(1) Install power steering tank on bracket.

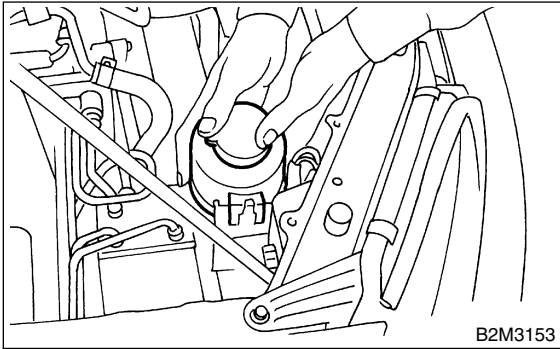

(2) Connect connector to power steering pump switch.

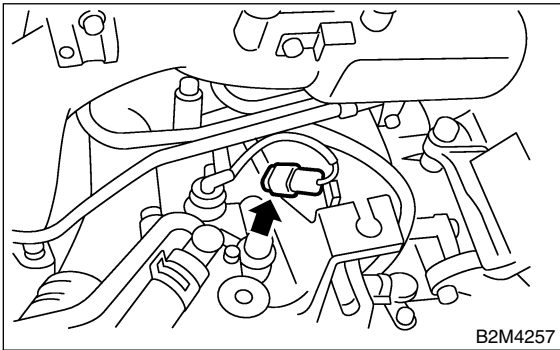

(3) Tighten bolts which install power steering pump on bracket.

Tightening torque:
20.1 N-m (2.05 kgf-m, 14.8 ft-lb)

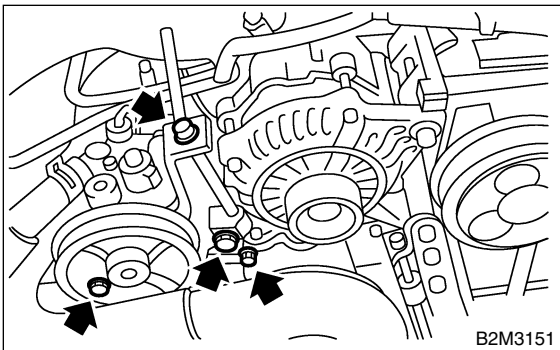

(4) Install power steering pipes onto right side intake manifold protector.

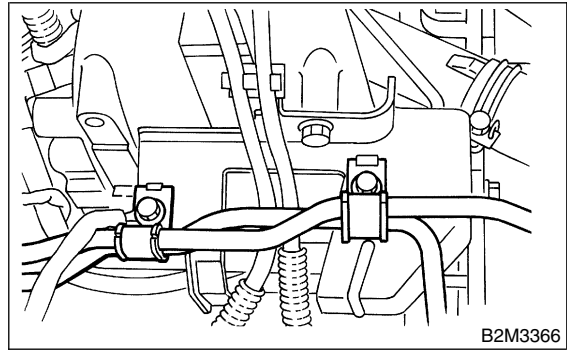

(5) Install power steering pump drive V-belt.

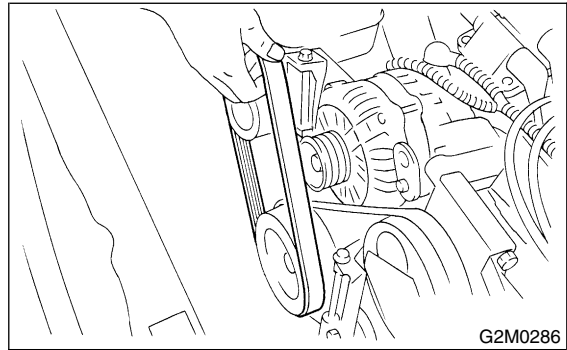

(6) Adjust V-belt. <Ref. to ME-42, REMOVAL, V-belt.>

(7) Install V-belt covers.

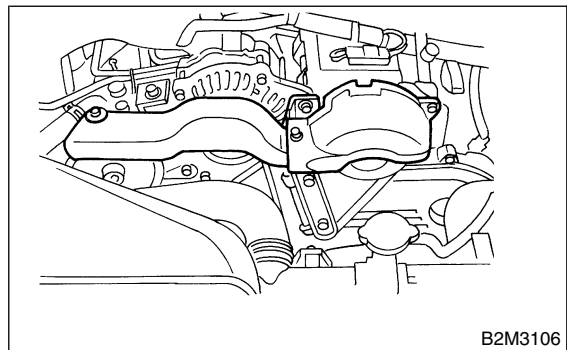

(8) Install resonator chamber.

Tightening torque:
33 N-m (3.4 kgf-m, 24.6 ft-lb)

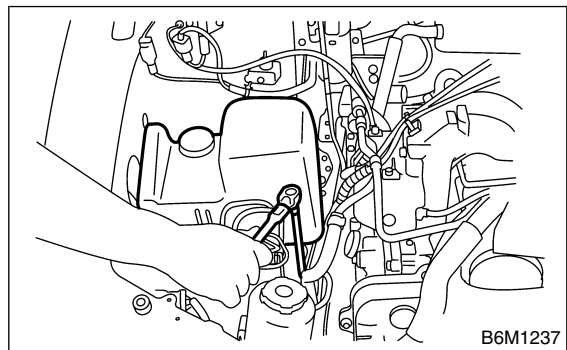

- 14) Connect accelerator cable (A).
- 15) Connect cruise control cable (B). (With cruise control models)

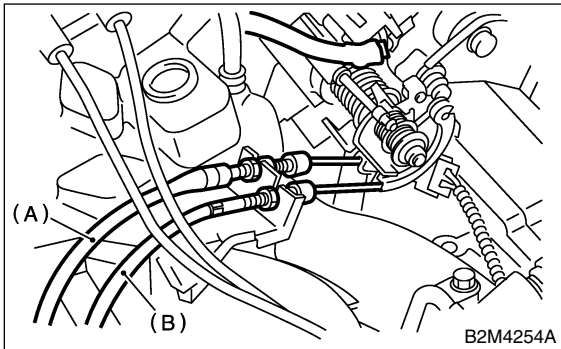

- 16) Install air intake duct and air cleaner case. <Ref. to IN-7, REMOVAL, Air Intake Duct.> and <Ref. to IN-6, REMOVAL, Air Cleaner Case.>
- 17) Connect connector to fuel pump relay.

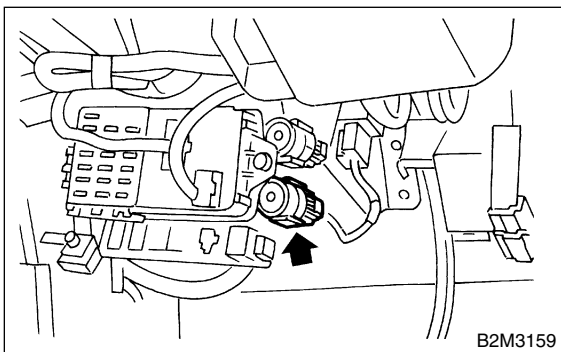

- 18) Connect battery ground cable.

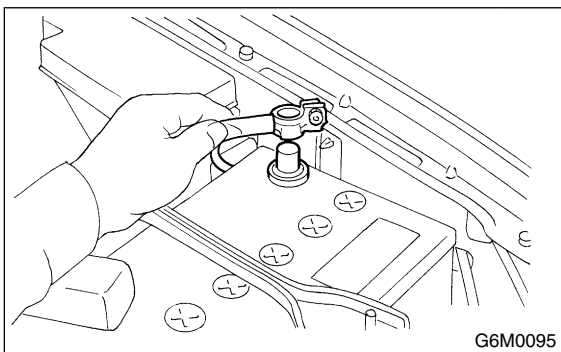

C: DISASSEMBLY S175034A06

- 1) Disconnect engine ground terminal from intake manifold.

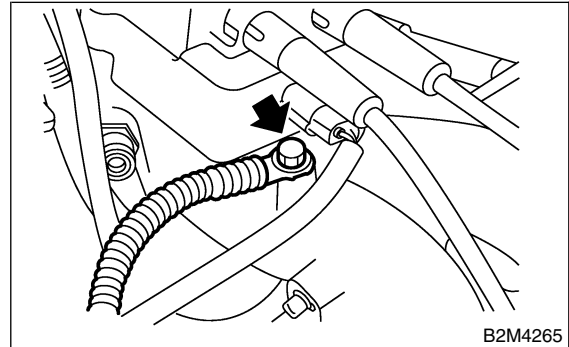

- 2) Disconnect connector from ignition coil and ignitor assembly.

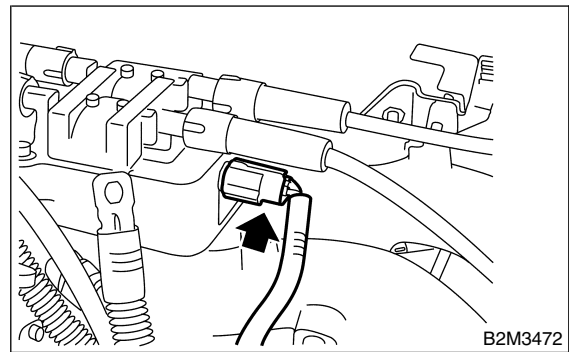

- 3) Remove ignition coil and ignitor assembly.

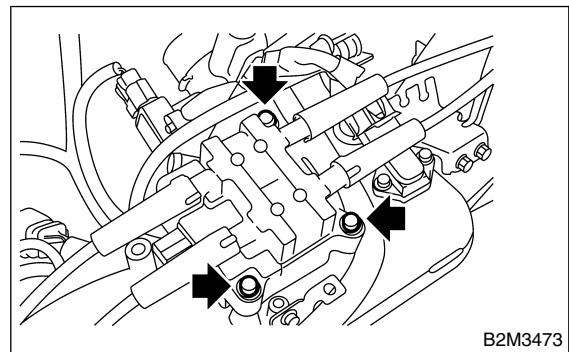

- 4) Disconnect connector from intake air temperature and pressure sensor.

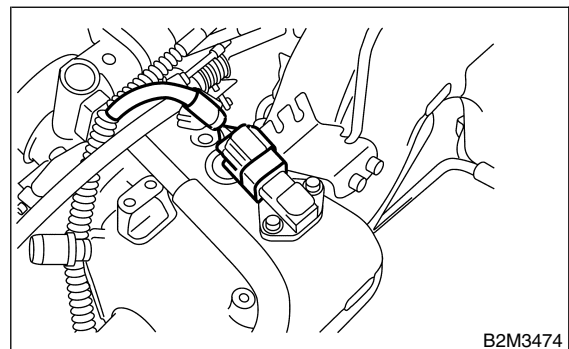

INTAKE MANIFOLD

Fuel Injection (Fuel Systems)

- 5) Remove intake air temperature and pressure sensor from intake manifold.

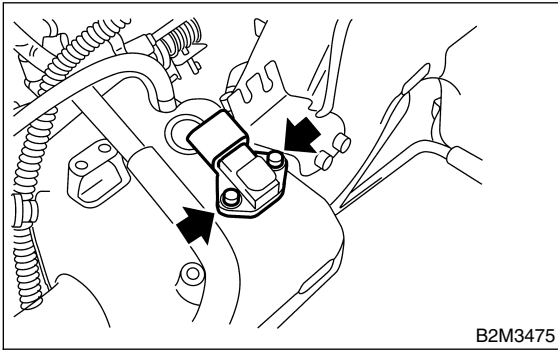

- 6) Disconnect connectors from throttle position sensor and idle air control solenoid valve.

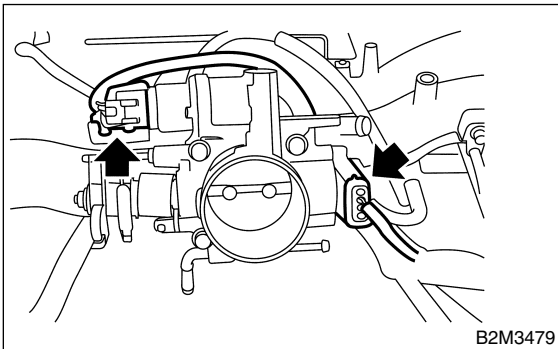

- 7) Disconnect air by-pass hose from throttle body.

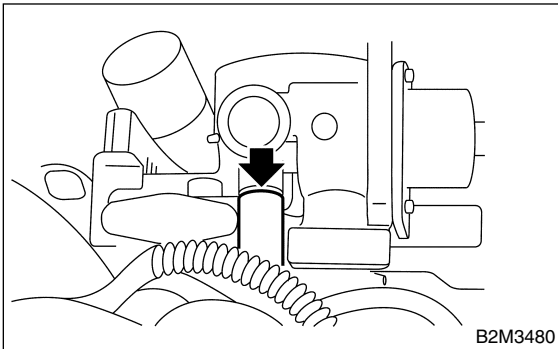

- 8) Remove throttle body.

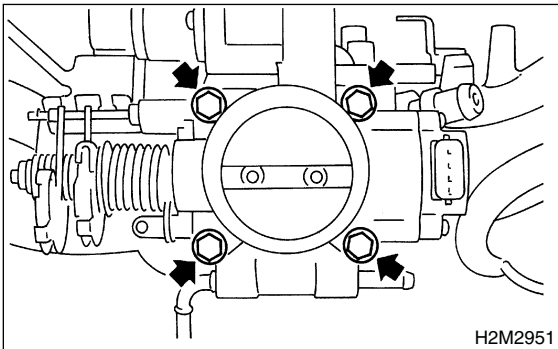

- 9) Disconnect connector from air assist injector solenoid valve.

- 10) Disconnect air by-pass hoses from air assist solenoid valve.

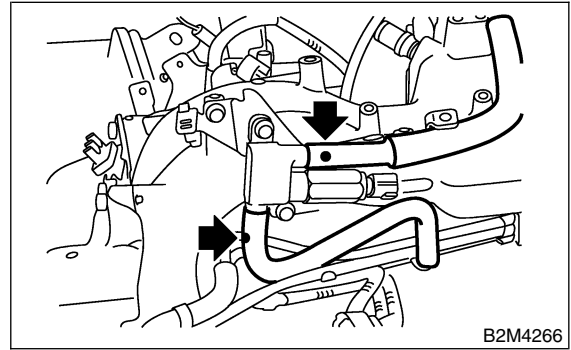

- 11) Remove air assist injector solenoid valve from intake manifold.

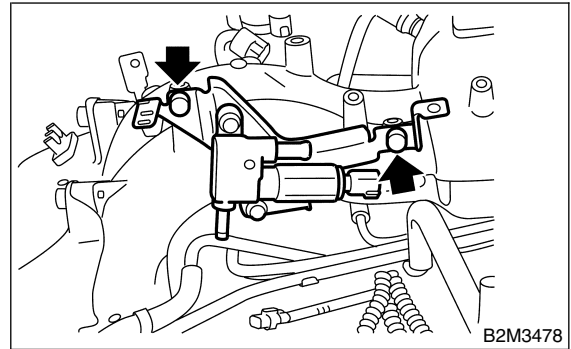

- 12) Disconnect pressure regulator vacuum hose from intake manifold.

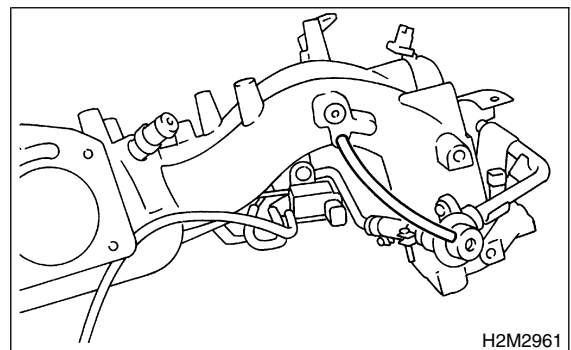

INTAKE MANIFOLD

Fuel Injection (Fuel Systems)

13) Remove fuel pipe protector LH.

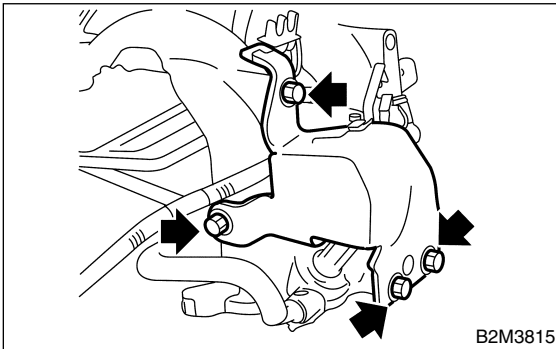
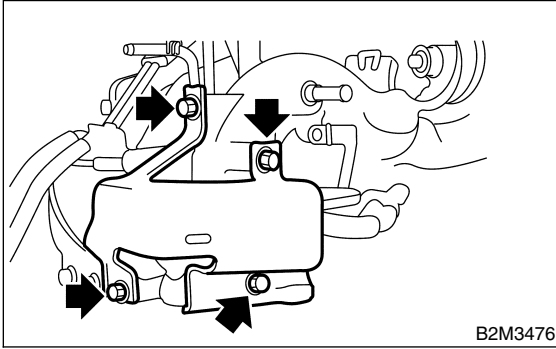

14) Remove fuel pipe protector RH.

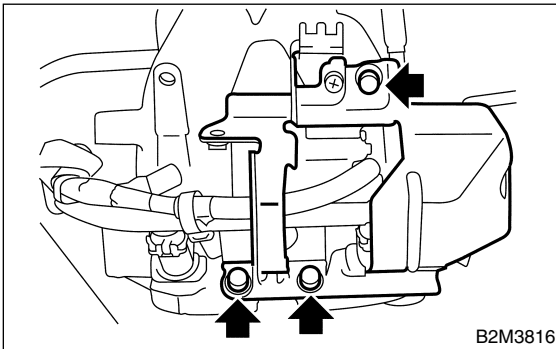

15) Disconnect connectors from fuel injectors.

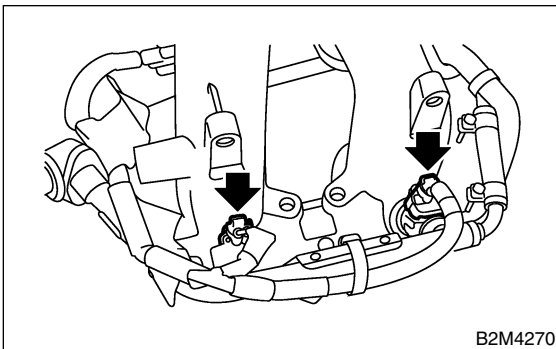

16) Disconnect connector from purge control solenoid valve.

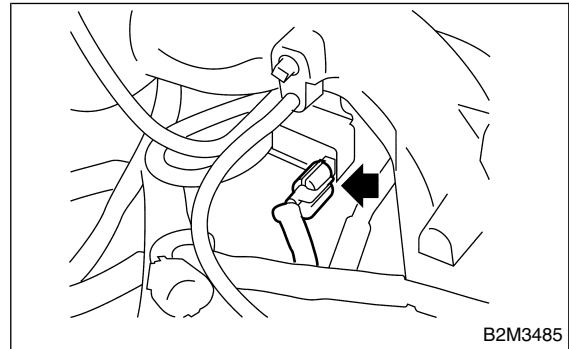

17) Disconnect air by-pass hose from purge control solenoid valve.

18) Remove harness bands (*) which hold engine harness onto intake manifold.

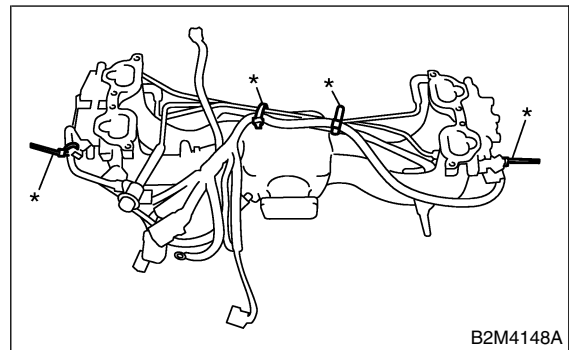

19) Remove engine harness from intake manifold.

20) Remove purge control solenoid valve.

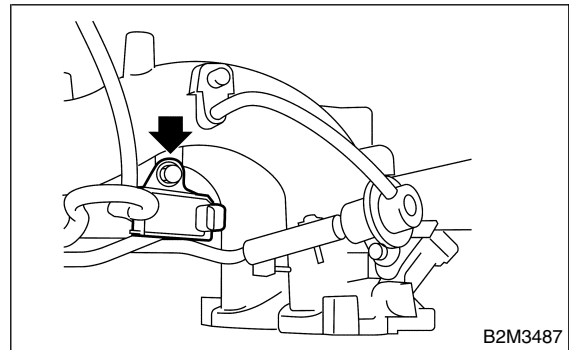

21) Remove bolt which installs injector pipe on intake manifold as shown in figure.

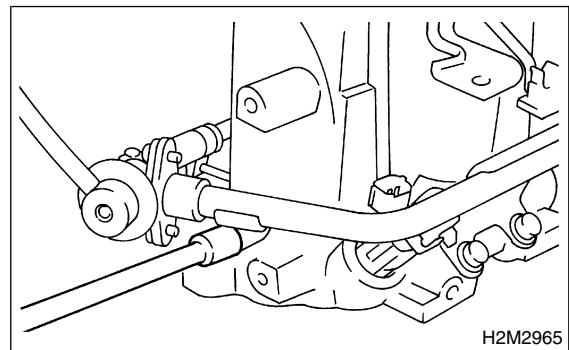

INTAKE MANIFOLD

Fuel Injection (Fuel Systems)

22) Remove bolt which installs injector pipe on intake manifold.

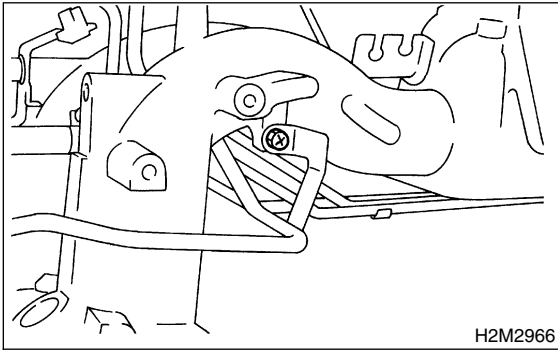

23) Remove two bolts which hold fuel pipes on the left side of intake manifold.

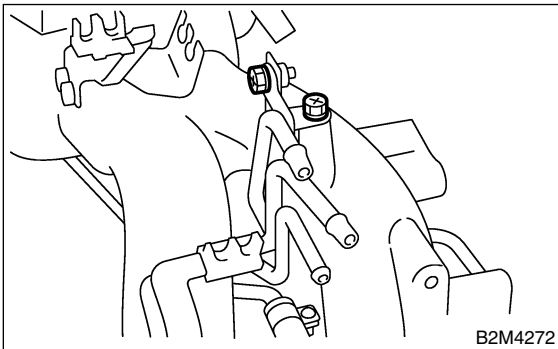

24) Remove fuel injectors.

(1) Remove fuel injector securing clip.

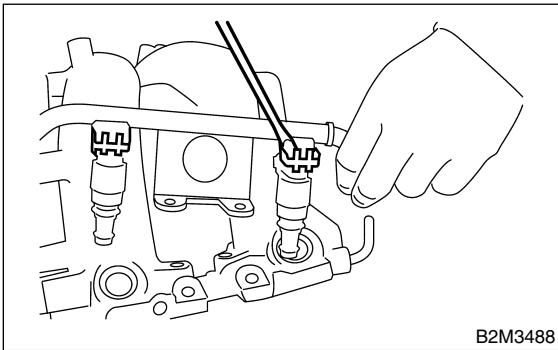

(2) Remove fuel injector while lifting up fuel injector pipe.

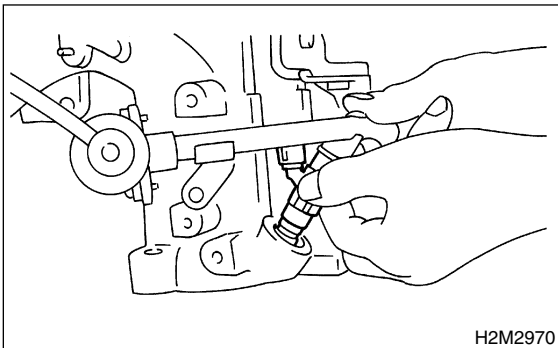

25) Disconnect air by-pass hoses from intake manifold.

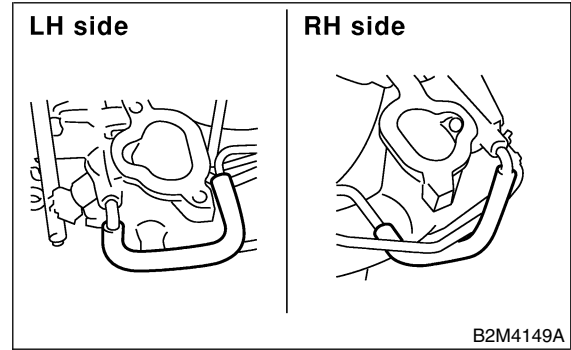

26) Loosen clamp which holds front left side fuel hose to injector pipe and remove the pipe from clamp.

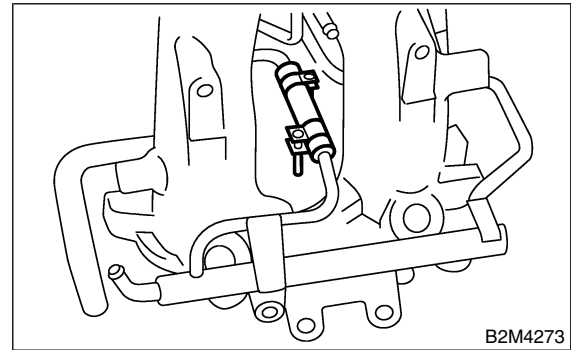

27) Loosen clamp which holds front right side fuel hose to injector pipe and remove the pipe from clamp.

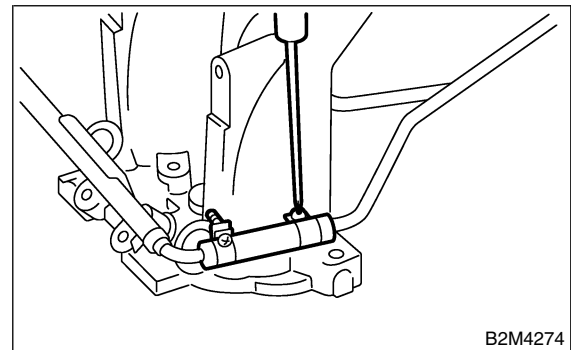

28) Remove fuel injector pipe.

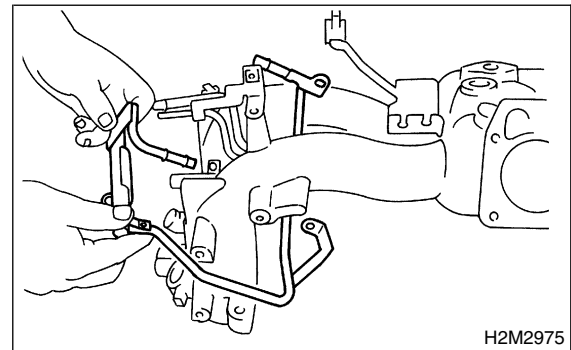

29) Remove bolt which installs fuel pipes on intake manifold.

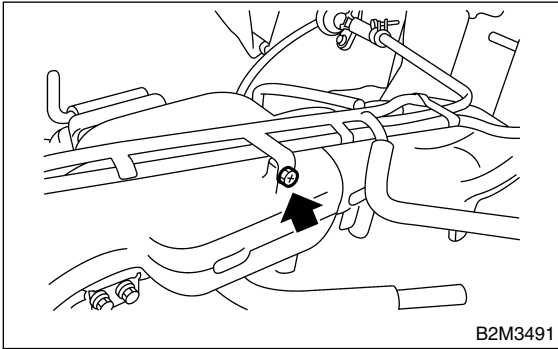

30) Remove fuel pipe assembly and pressure regulator, from intake manifold.

D: ASSEMBLY S175034A02

- 1) Install fuel pipe assembly and pressure regulator, etc. to intake manifold.
- 2) Tighten bolt which installs fuel pipes on intake manifold.

Tightening torque:
4.9 N·m (0.5 kgf-m, 3.6 ft-lb)

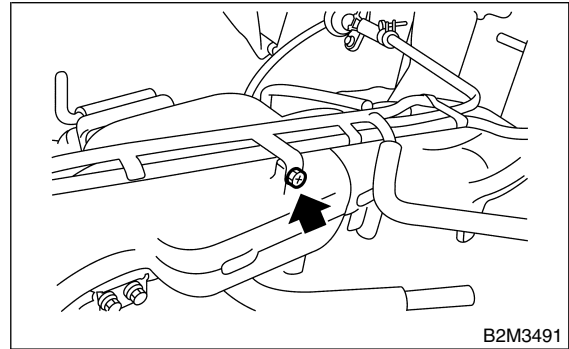

- 3) Connect right side fuel hose to injector pipe, and tighten clamp screw.

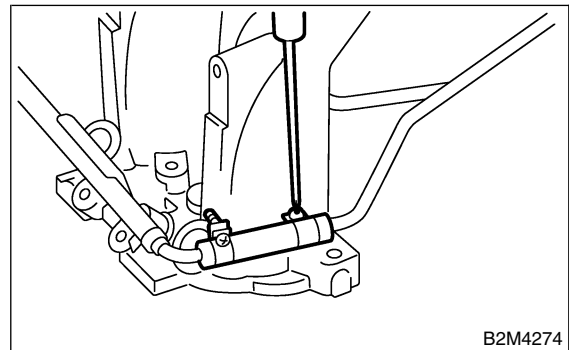

- 4) Install fuel injector pipe.

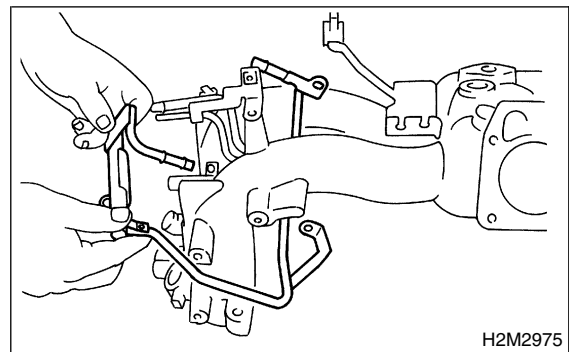

INTAKE MANIFOLD

Fuel Injection (Fuel Systems)

- 5) Connect left side fuel hose to injector pipe, and tighten clamp screw.

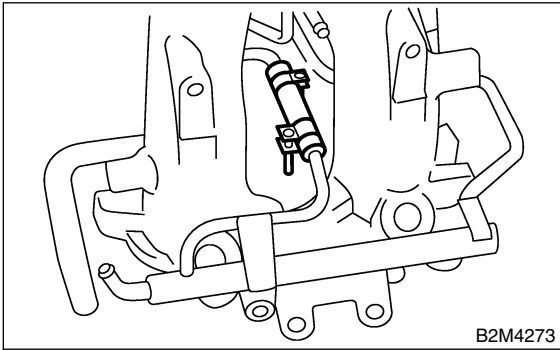

- 6) Connect air assist hoses.

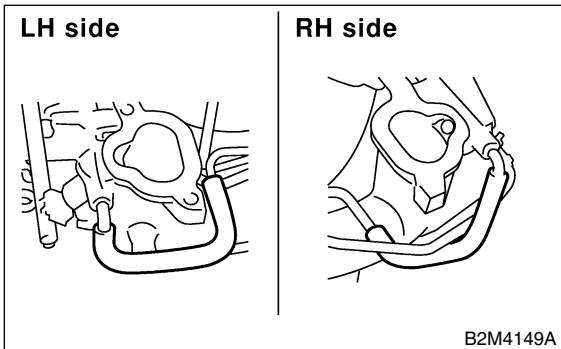

- 7) Install fuel injectors.

NOTE:

Always use new o-rings.

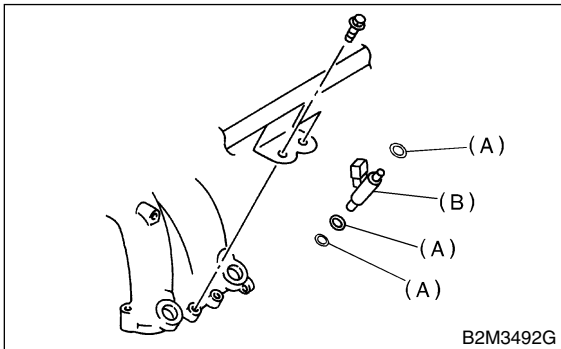

- (A) O-ring
(B) Fuel injector

NOTE:

Do not forget to install the fuel injector securing clip.

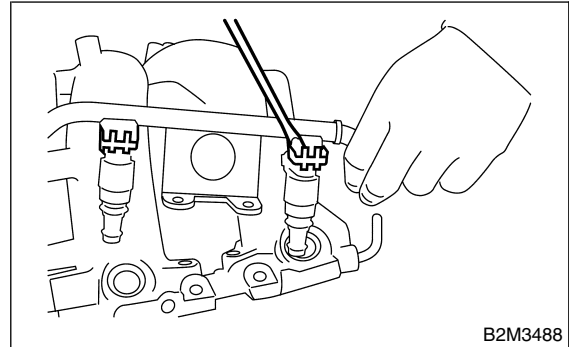

- 8) Tighten bolt which installs injector pipe on intake manifold.

Tightening torque:

5.0 N·m (0.51 kgf·m, 3.7 ft·lb)

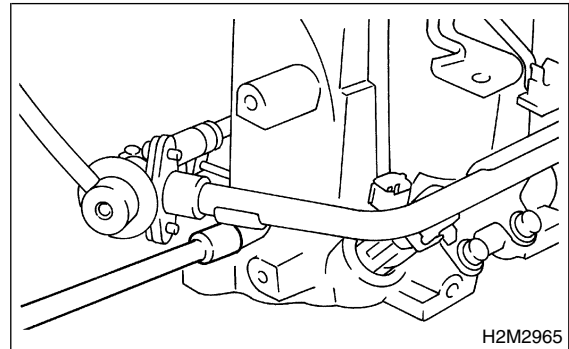

- 9) Tighten two bolts which install fuel pipes on the left side of intake manifold.

Tightening torque:

5.0 N·m (0.51 kgf·m, 3.7 ft·lb)

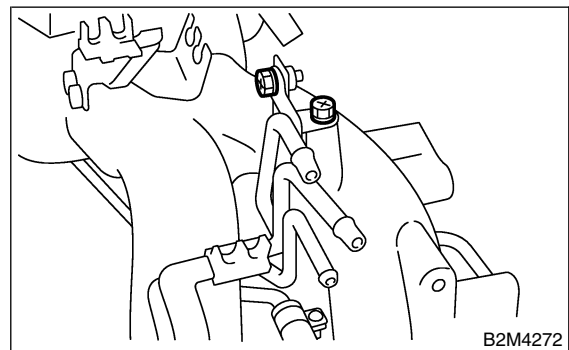

INTAKE MANIFOLD

Fuel Injection (Fuel Systems)

10) Tighten bolt which install injector pipe on intake manifold.

Tightening torque:

5.0 N·m (0.51 kgf-m, 3.7 ft-lb)

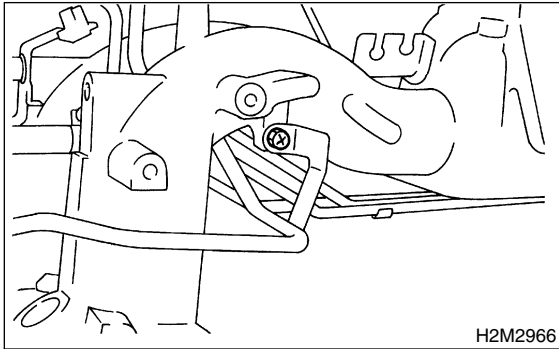

13) Install engine harness onto intake manifold.
14) Connect connectors to fuel injectors and purge control solenoid valve.
15) Hold engine harness by harness bands (*).

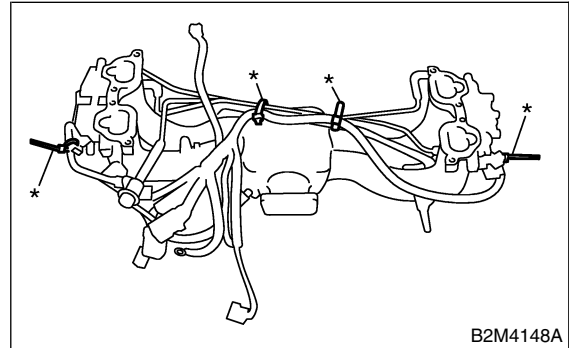

11) Install purge control solenoid valve.

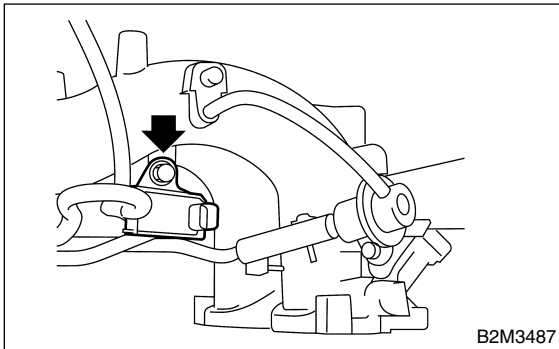

NOTE:

Do not use harness band on harnesses where they are supposed to be protected by the fuel pipe protector.

16) Install fuel pipe protector RH.

Tightening torque:

19 N·m (1.9 kgf-m, 13.7 ft-lb)

12) Connect hoses to purge control solenoid valve.

CAUTION:

Carefully connect the evaporation hoses.

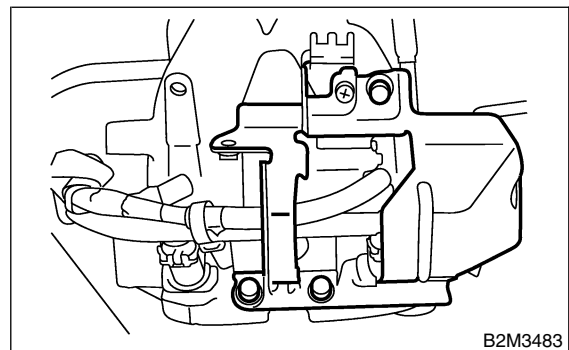
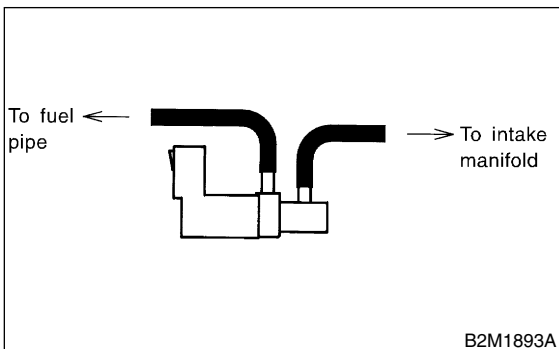

INTAKE MANIFOLD

Fuel Injection (Fuel Systems)

17) Install fuel pipe protector LH.

Tightening torque:

19 N·m (1.9 kgf·m, 13.7 ft·lb)

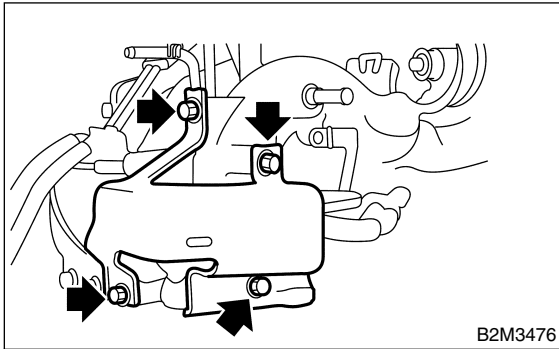
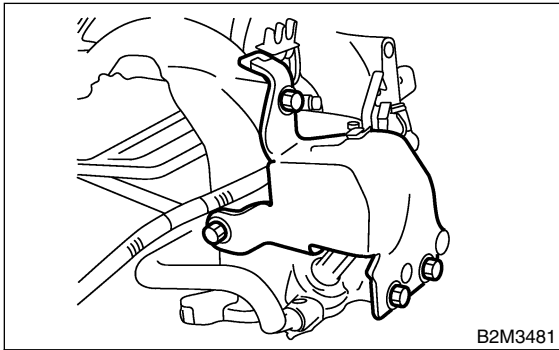

18) Connect pressure regulator vacuum hose to intake manifold.

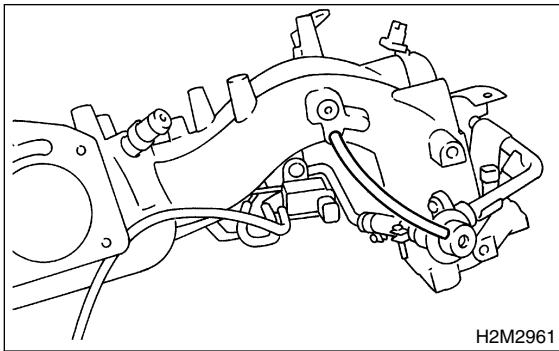

19) Install air assist injector solenoid valve to bracket.

Tightening torque:

5.0 N·m (0.51 kgf·m, 3.7 ft·lb)

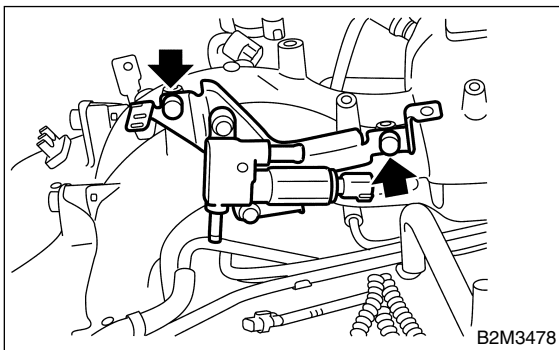

20) Connect air by-pass hoses to air assist solenoid valve.

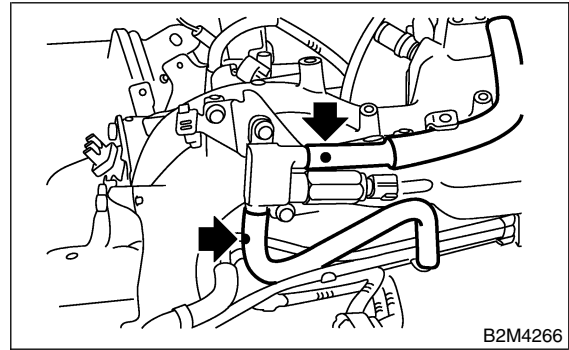

21) Connect connector to air assist solenoid valve.

22) Install throttle body to intake manifold.

NOTE:

Replace gasket with a new one.

Tightening torque:

22 N·m (2.2 kgf·m, 15.9 ft·lb)

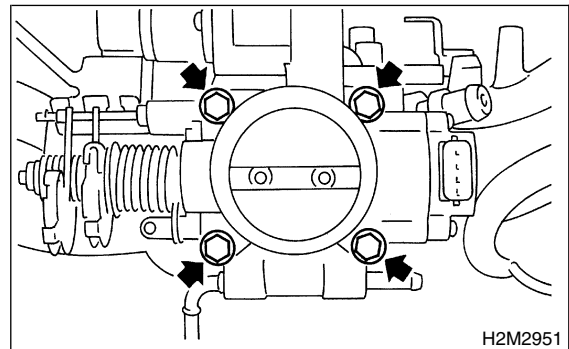

23) Connect connector to throttle position sensor and idle air control solenoid valve.

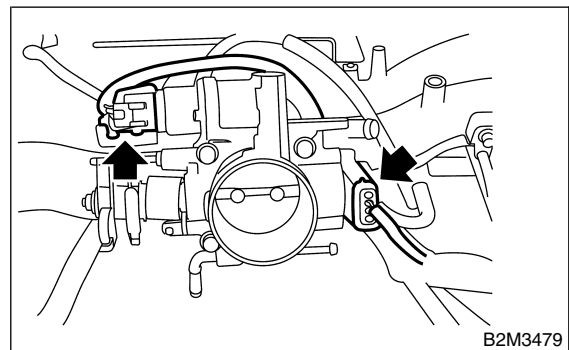

INTAKE MANIFOLD

Fuel Injection (Fuel Systems)

24) Connect air by-pass hose to throttle body.

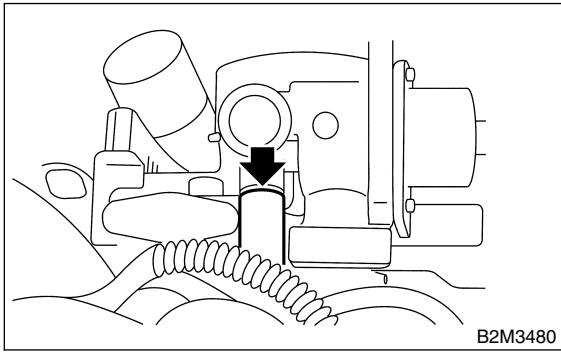

25) Install intake air temperature and pressure sensor.

Tightening torque:

3.4 N·m (0.35 kgf·m, 2.5 ft·lb)

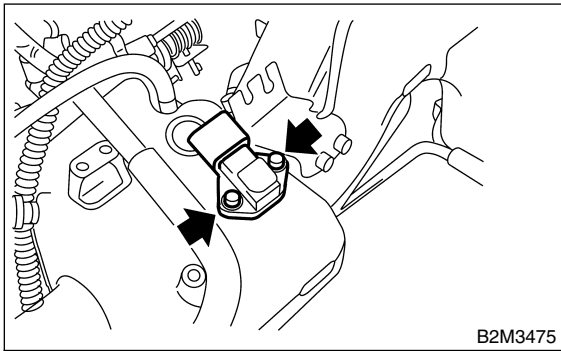

NOTE:

Replace O-ring with a new one.

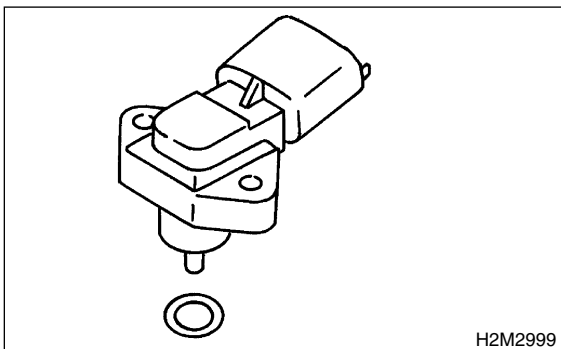

26) Connect connector to intake air temperature and pressure sensor.

27) Install ignition coil and ignitor assembly.

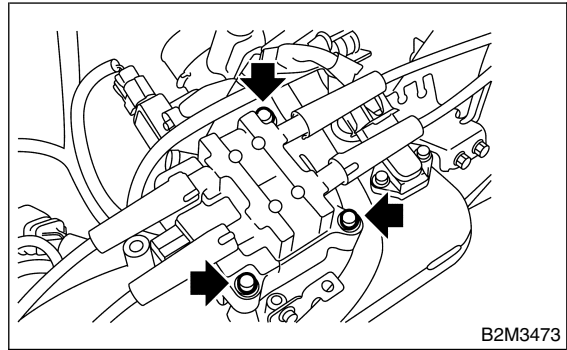

28) Connect connector to ignition coil and ignitor assembly.

29) Install engine ground terminal to intake manifold.

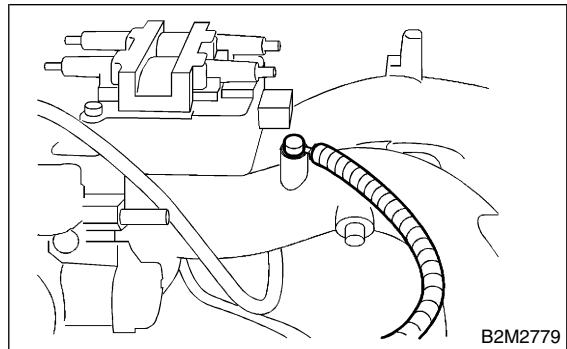

E: INSPECTION S175034A10

Make sure the fuel pipe and fuel hoses are not cracked and that connections are tight.