

SPARK PLUG

Ignition

2. Spark Plug S171003

A: REMOVAL S171003A18

CAUTION:

All spark plugs installed on an engine, must be of the same heat range.

Spark plug:

CHAMPION: RC10YC4

(Alternate)

NGK: BKR5E-11

NGK: BKR6E-11

1. RH SIDE S171003A1805

- 1) Disconnect battery ground cable.

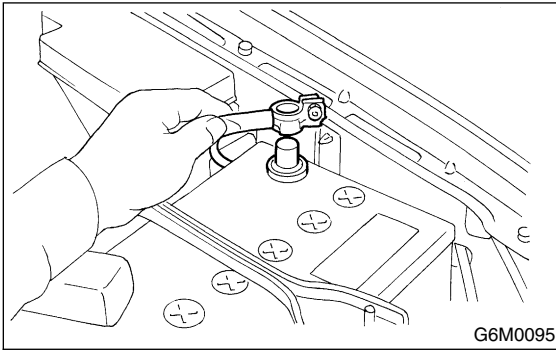

- 2) Remove resonator chamber.

<Ref. to IN-8, REMOVAL, Resonator Chamber.>

- 3) Remove spark plug cords by pulling boot, not cord itself.

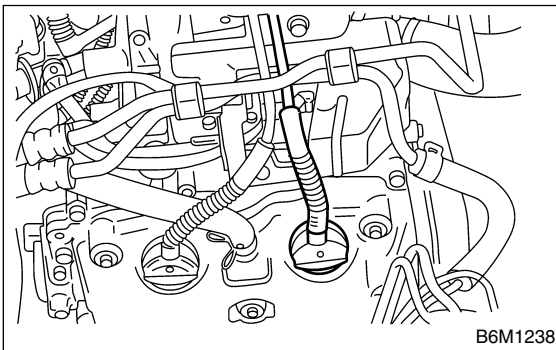

- 4) Remove spark plugs with the spark plug socket.

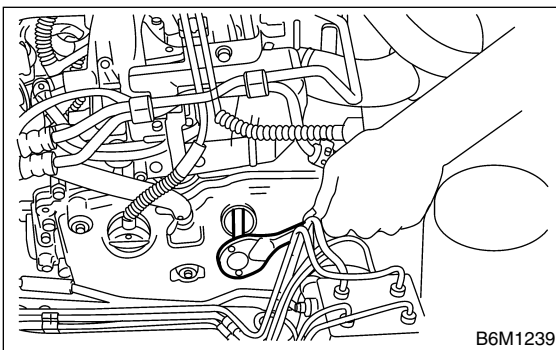

2. LH SIDE S171003A1806

- 1) Disconnect battery ground cable.

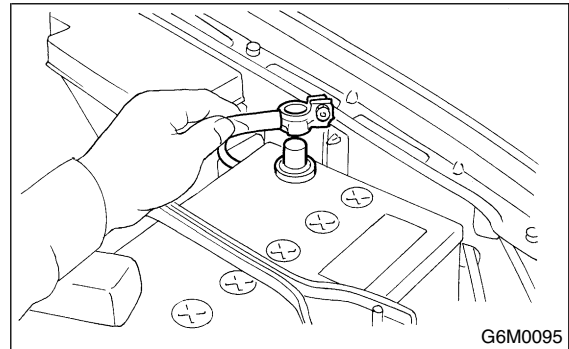

- 2) Disconnect washer motor connector.

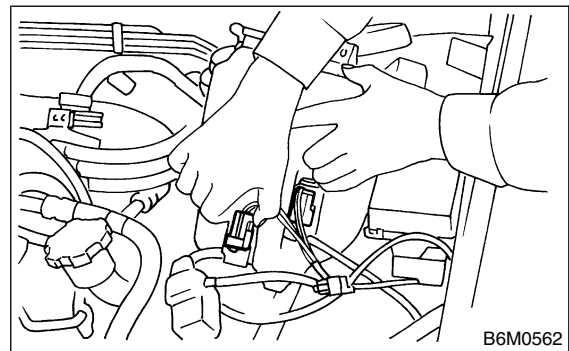

- 3) Disconnect rear window glass washer hose from washer motor, then plug connection with a suitable cap.

- 4) Remove the two bolts which hold the washer tank, then take the tank away from the working area.

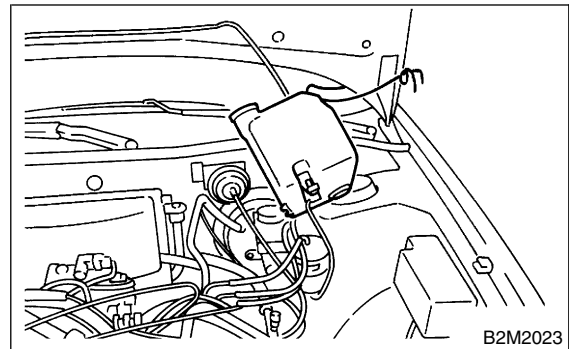

5) Remove spark plugs cord by pulling boot, not cord itself.

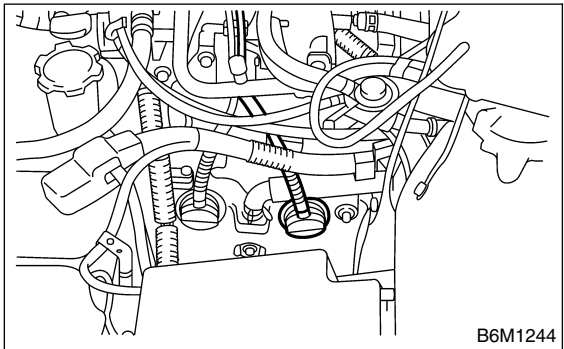

6) Remove spark plug with the spark plugs socket.

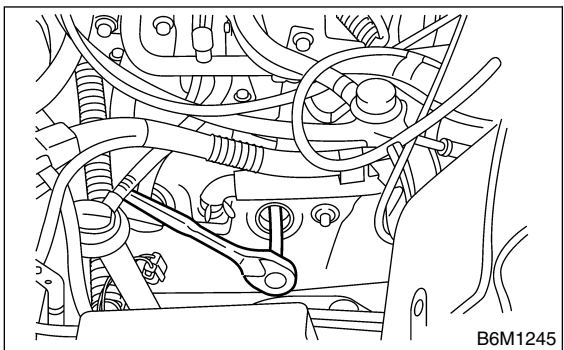

B: INSTALLATION S171003A11

1. RH SIDE S171003A1105

1) Install in the reverse order of removal.

Tightening torque (Spark plug):
21 N·m (2.1 kgf·m, 15 ft·lb)

CAUTION:

The above torque should be only applied to new spark plugs without oil on their threads. In case their threads are lubricated, the torque should be reduced by approximately 1/3 of the specified torque in order to avoid over-stressing.

Tightening torque (Resonator chamber):
33 N·m (3.4 kgf·m, 24.6 ft·lb)

2. LH SIDE S171003A1106

1) Install in the reverse order of removal.

Tightening torque (Spark plug):
21 N·m (2.1 kgf·m, 15 ft·lb)

CAUTION:

The above torque should be only applied to new spark plugs without oil on their threads. In case their threads are lubricated, the torque should be reduced by approximately 1/3 of the specified torque in order to avoid over-stressing.

C: INSPECTION S171003A10

Check electrodes and inner and outer porcelain of plugs, noting the type of deposits and the degree of electrode erosion.

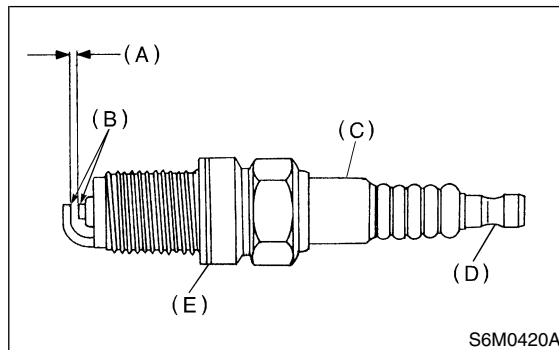

- (A) Electrode gap
- (B) Carbon accumulation or wear
- (C) Cracks
- (D) Damage
- (E) Damaged gasket

1) Normal

Brown to grayish-tan deposits and slight electrode wear indicate correct spark plug heat range.

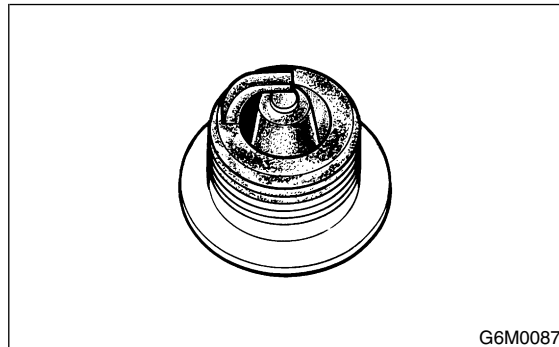

2) Carbon fouled

Dry fluffy carbon deposits on insulator and electrode are mostly caused by slow speed driving in city, weak ignition, too rich fuel mixture, dirty air cleaner, etc.

It is advisable to replace with plugs having hotter heat range.

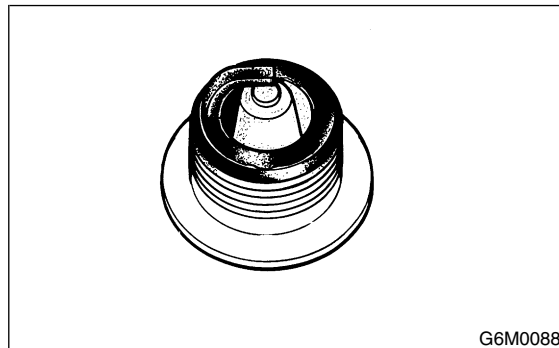

SPARK PLUG

Ignition

3) Oil fouled

Wet black deposits show excessive oil entrance into combustion chamber through worn rings and pistons or excessive clearance between valve guides and stems. If same condition remains after repair, use a hotter plug.

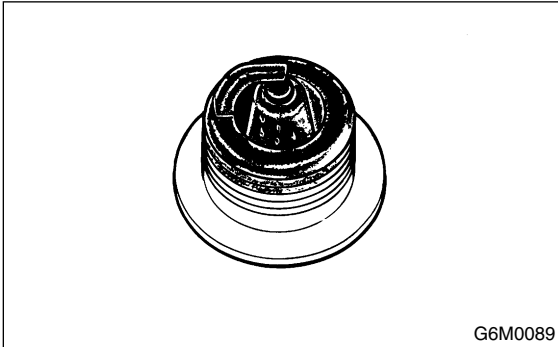

4) Overheating

White or light gray insulator with black or gray brown spots and bluish burnt electrodes indicate engine overheating. Moreover, the appearance results from incorrect ignition timing, loose spark plugs, wrong selection of fuel, hotter range plug, etc. It is advisable to replace with plugs having colder heat range.

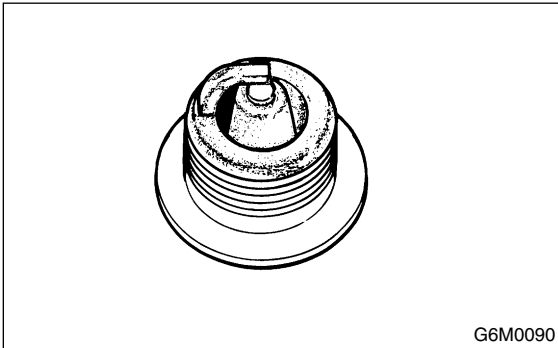

E: ADJUSTMENT S171003A01

Correct it if the spark plug gap is measured with a gap gauge, and it is necessary.

Spark plug gap: L

1.0 — 1.1 mm (0.039 — 0.043 in)

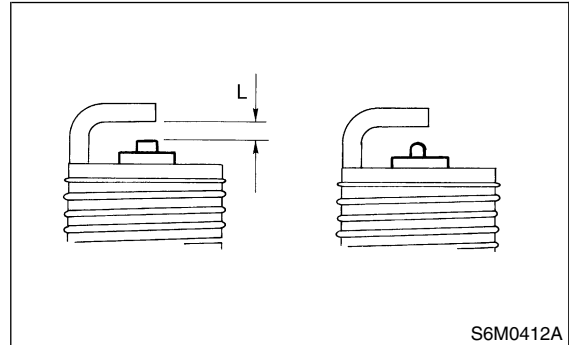

NOTE:

Replace with new spark plug if this area is worn to "ball" shape.

D: CLEANING S171003E56

Clean spark plugs in a sand blast type cleaner. Avoid excessive blasting. Clean and remove carbon or oxide deposits, but do not wear away porcelain.

If deposits are too stubborn, replace plugs.