

7. Engine Oil Filter S178585

A: REMOVAL S178585A18

- 1) Remove access lid.

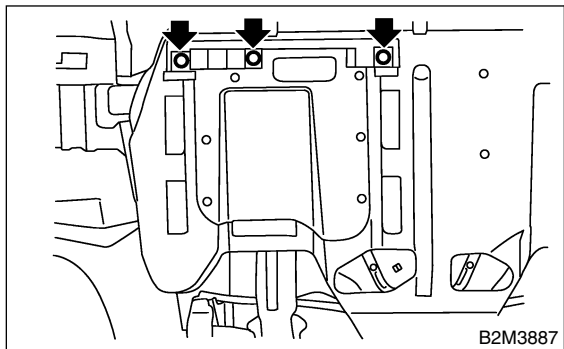

- 2) Remove oil filter with ST.
ST 498547000 OIL FILTER WRENCH

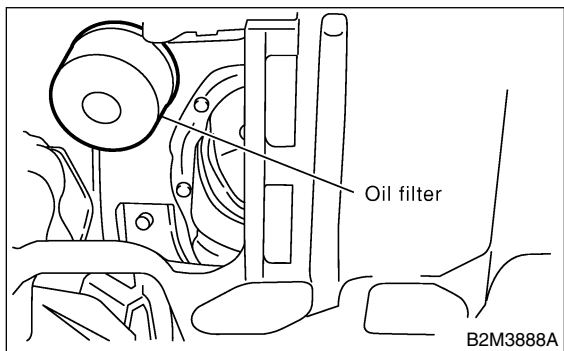

B: INSTALLATION S178585A11

- 1) Get a new oil filter and apply a thin coat of engine oil to the seal rubber.
- 2) Install oil filter by turning it by hand, being careful not to damage seal rubber.
- 3) Tighten more (approximately 2/3 to 3/4 turn) after the seal rubber contacts the oil pump case. Do not tighten excessively, or oil may leak.

C: INSPECTION S178585A10

- 1) After installing oil filter, run engine and make sure that no oil is leaking around seal rubber.

NOTE:

The filter element and filter case are permanently jointed; therefore, interior cleaning is not necessary.

- 2) Check the engine oil level. <Ref. to LU-7, INSPECTION, Engine Oil.>