

## 6. Engine Oil Pressure

S173655

### A: INSPECTION

S173655A10

- 1) Disconnect battery ground cable.

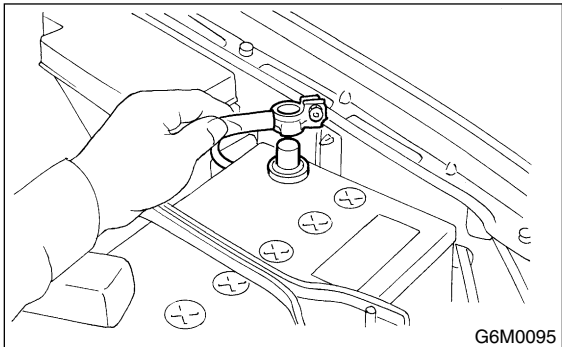

G6M0095

- 2) Remove generator from bracket. <Ref. to SC-15, REMOVAL, Generator.>
- 3) Disconnect connector from oil pressure switch.
- 4) Remove oil pressure switch from engine cylinder block. <Ref. to LU-17, REMOVAL, Oil Pressure Switch.>

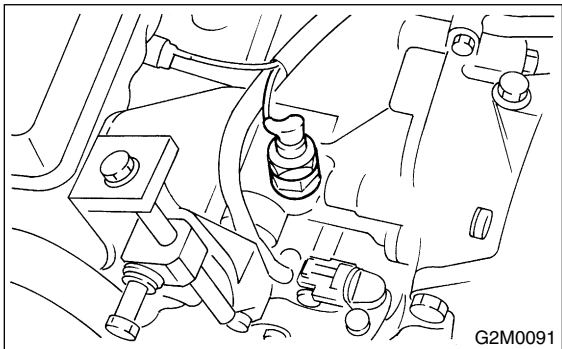

G2M0091

- 5) Connect oil pressure gauge hose to cylinder block.
- 6) Connect battery ground cable.

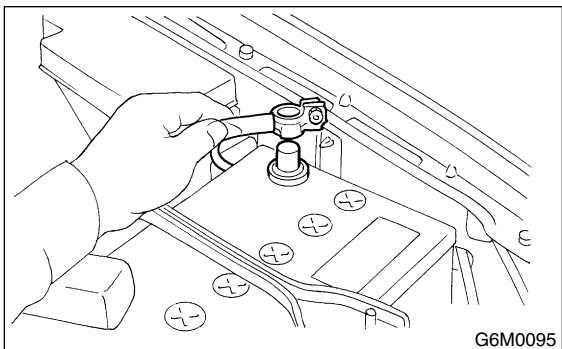

G6M0095

- 7) Start the engine, and measure oil pressure.

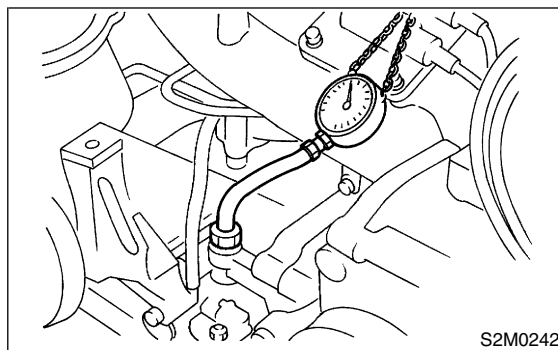

S2M0242

#### Oil pressure:

98 kPa (1.0 kg/cm<sup>2</sup>, 14 psi) or more at 800 rpm

294 kPa (3.0 kg/cm<sup>2</sup>, 43 psi) or more at 5,000 rpm

#### CAUTION:

- If oil pressure is out of specification, check oil pump, oil filter and lubrication line. <Ref. to LU-19, INSPECTION, Engine Lubrication System Trouble in General.>
- If oil pressure warning light is turned ON and oil pressure is in specification, replace oil pressure switch. <Ref. to LU-19, INSPECTION, Engine Lubrication System Trouble in General.>

#### NOTE:

The specified data is based on an engine oil temperature of 80°C (176°F).

- 8) After measuring oil pressure, install oil pressure switch. <Ref. to LU-17, INSTALLATION, Oil Pressure Switch.>

#### Tightening torque:

25 N·m (2.5 kgf·m, 18.1 ft·lb)

- 9) Install generator and V-belt in the reverse order of removal, and adjust the V-belt deflection. <Ref. to ME-42, INSTALLATION, V-belt.>