

14. Belt Cover S173582

A: REMOVAL S173582A18

- 1) Remove V-belt. <Ref. to ME-42, REMOVAL, V-belt.>
- 2) Remove crankshaft pulley. <Ref. to ME-44, REMOVAL, Crankshaft Pulley.>
- 3) Remove belt cover (LH).
- 4) Remove front belt cover.

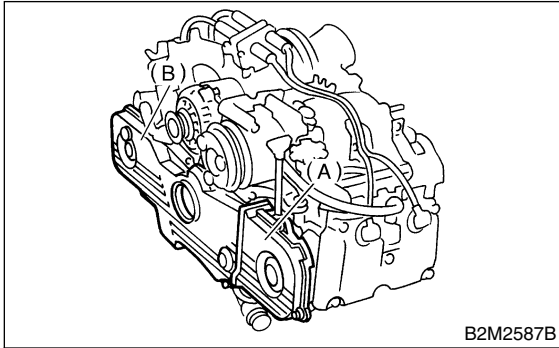

- (A) Belt cover (LH)
 (B) Front belt cover

B: INSTALLATION S173582A11

- 1) Install front belt cover.

Tightening torque:

5 N·m (0.5 kgf·m, 3.6 ft·lb)

- 2) Install belt cover (LH).

Tightening torque:

5 N·m (0.5 kgf·m, 3.6 ft·lb)

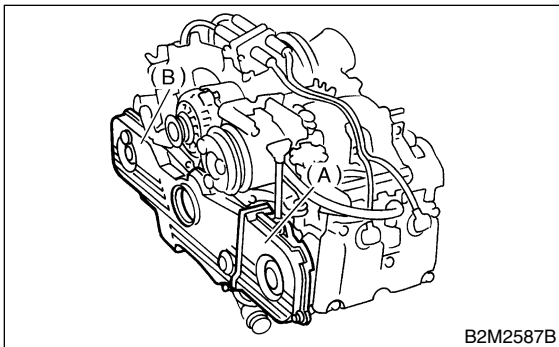

- (A) Belt cover (LH)
 (B) Front belt cover

- 3) Install crankshaft pulley. <Ref. to ME-44, INSTALLATION, Crankshaft Pulley.>
- 4) Install V-belt. <Ref. to ME-42, INSTALLATION, V-belt.>

C: INSPECTION S173582A10

Make sure the cover is not damaged.