

## 20. Cylinder Head Assembly S173093

### A: REMOVAL S173093A18

- 1) Remove V-belt. <Ref. to ME-42, REMOVAL, V-belt.>
- 2) Remove crankshaft pulley. <Ref. to ME-44, REMOVAL, Crankshaft Pulley.>
- 3) Remove belt cover. <Ref. to ME-45, REMOVAL, Belt Cover.>
- 4) Remove timing belt assembly. <Ref. to ME-46, REMOVAL, Timing Belt Assembly.>
- 5) Remove camshaft sprocket. <Ref. to ME-51, REMOVAL, Camshaft Sprocket.>
- 6) Remove intake manifold. <Ref. to FU-15, REMOVAL, Intake Manifold.>
- 7) Remove bolt which installs A/C compressor bracket on cylinder head.
- 8) Remove valve rocker assembly. <Ref. to ME-53, REMOVAL, Valve Rocker Assembly.>
- 9) Remove camshaft. <Ref. to ME-55, REMOVAL, Camshaft.>
- 10) Remove cylinder head bolts in alphabetical sequence shown in figure.

#### CAUTION:

Leave bolts (a) and (c) engaged by three or four threads to prevent cylinder head from falling.

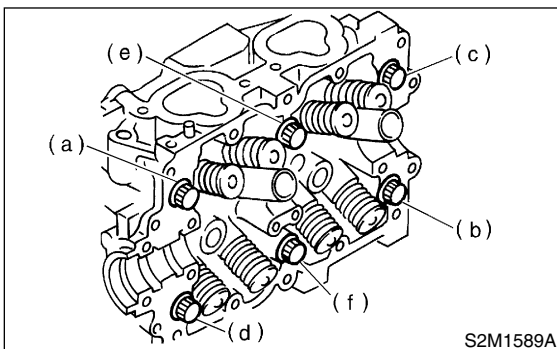

- 11) While tapping cylinder head with a plastic hammer, separate it from cylinder block.
- 12) Remove bolts (a) and (b) to remove cylinder head.

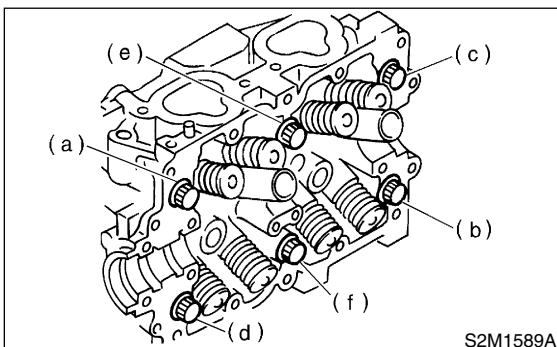

- 13) Remove cylinder head gasket.

#### CAUTION:

Do not scratch the mating surface of cylinder head and cylinder block.

- 14) Similarly, remove right side cylinder head.

### B: INSTALLATION S173093A11

#### 1. CYLINDER HEAD S173093A1102

- 1) Install cylinder head and gaskets on cylinder block.

#### CAUTION:

- Use new cylinder head gaskets.
- Be careful not to scratch the mating surface of cylinder block and oil pump.

- 2) Tighten cylinder head bolts.
  - (1) Apply a coat of engine oil to washers and bolt threads.
  - (2) Tighten all bolts to 29 N·m (3.0 kgf·m, 22 ft·lb) in alphabetical sequence.
  - Then tighten all bolts to 69 N·m (7.0 kgf·m, 51 ft·lb) in alphabetical sequence.
  - (3) Back off all bolts by 180° first; back them off by 180° again.
  - (4) Tighten bolts (a) and (b) to 34 N·m (3.5 kgf·m, 25 ft·lb).
  - (5) Tighten bolts (c), (d), (e) and (f) to 15 N·m (1.5 kgf·m, 11 ft·lb).
  - (6) Tighten all bolts by 80 to 90° in alphabetical sequence.

#### CAUTION:

Do not tighten bolts more than 90°.

- (7) Further tighten all bolts by 80 to 90° in alphabetical sequence shown in figure below.

#### CAUTION:

Ensure that the total “re-tightening angle” [in the former two steps], do not exceed 180°.

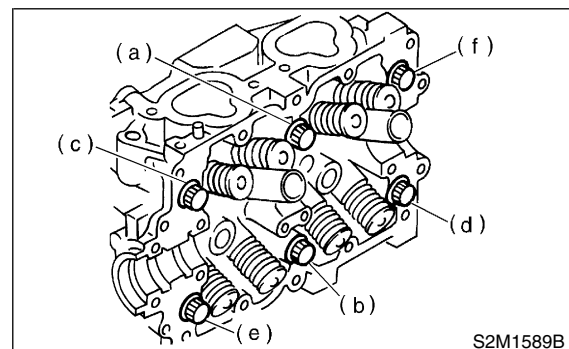

- 3) Install camshaft. <Ref. to ME-56, INSTALLATION, Camshaft.>
- 4) Install valve rocker assembly. <Ref. to ME-53, INSTALLATION, Valve Rocker Assembly.>
- 5) Install A/C compressor bracket on cylinder head.

# CYLINDER HEAD ASSEMBLY

Mechanical

- 6) Install intake manifold. <Ref. to FU-18, INSTALLATION, Intake Manifold.>
- 7) Install camshaft sprocket. <Ref. to ME-51, INSTALLATION, Camshaft Sprocket.>
- 8) Install timing belt assembly. <Ref. to ME-47, INSTALLATION, Timing Belt Assembly.>
- 9) Install belt cover. <Ref. to ME-45, INSTALLATION, Belt Cover.>
- 10) Install crankshaft pulley. <Ref. to ME-44, INSTALLATION, Crankshaft Pulley.>
- 11) Install V-belt. <Ref. to ME-42, INSTALLATION, V-belt.>

## C: DISASSEMBLY S173093A06

- 1) Place cylinder head on ST.  
ST 498267800 CYLINDER HEAD TABLE
- 2) Set ST on valve spring. Compress valve spring and remove the valve spring retainer key. Remove each valve and valve spring.  
ST 499718000 VALVE SPRING REMOVER

### CAUTION:

- Mark each valve to prevent confusion.
- Use extreme care not to damage the lips of the intake valve oil seals and exhaust valve oil seals.

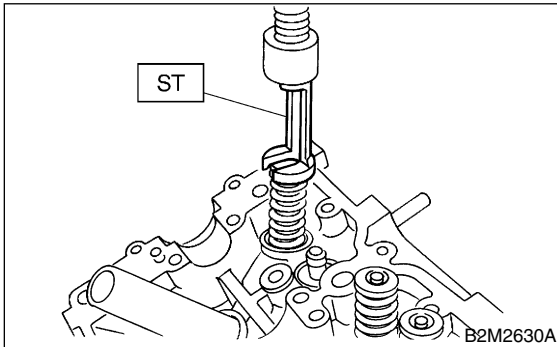

## D: ASSEMBLY S173093A02

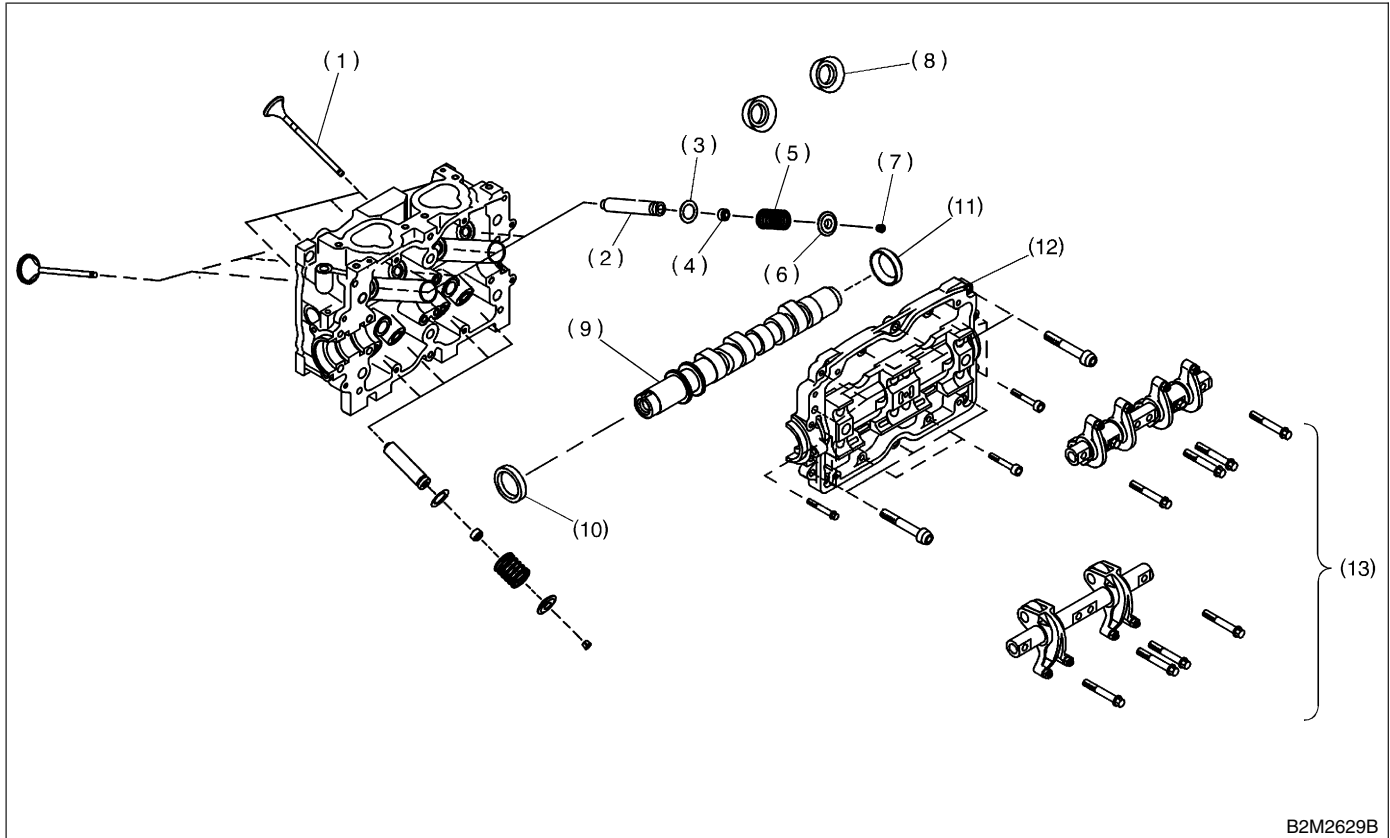

B2M2629B

- |                       |                       |                        |
|-----------------------|-----------------------|------------------------|
| (1) Valve             | (6) Retainer          | (11) Plug              |
| (2) Valve guide       | (7) Retainer key      | (12) Camshaft cap      |
| (3) Valve spring seat | (8) Spark plug gasket | (13) Valve rocker ASSY |
| (4) Oil seal          | (9) Camshaft          |                        |
| (5) Valve spring      | (10) Oil seal         |                        |

- 1) Installation of valve spring and valve  
 (1) Place cylinder head on ST.  
 ST 498267800 CYLINDER HEAD TABLE  
 (2) Coat stem of each valve with engine oil and insert valve into valve guide.

**CAUTION:**  
 When inserting valve into valve guide, use special care not to damage the oil seal lip.

- (3) Install valve spring and retainer.

**CAUTION:**  
 Be sure to install the valve springs with their close-coiled end facing the seat on the cylinder head.

- (4) Set ST on valve spring.  
 ST 499718000 VALVE SPRING REMOVER

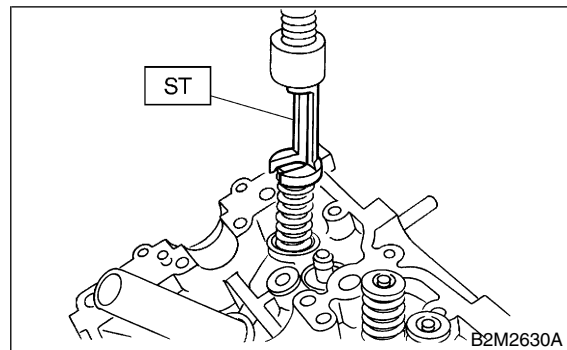

B2M2630A

# CYLINDER HEAD ASSEMBLY

Mechanical

(5) Compress valve spring and fit valve spring retainer key.

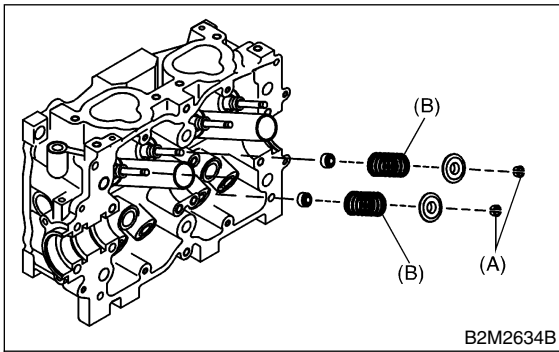

- (A) Retainer key
- (B) Painted face

(6) After installing, tap valve spring retainers lightly with wooden hammer for better seating.

## E: INSPECTION

S173093A10

### 1. VALVE SPRING

S173093A1001

- 1) Check valve springs for damage, free length, and tension. Replace valve spring if it is not to the specifications presented below.
- 2) To measure the squareness of the valve spring, stand the spring on a surface plate and measure its deflection at the top using a try square.

Free length	54.30 mm (2.1378 in)
Squareness	2.5°, 2.4 mm (0.094 in)
Tension/spring height	214.8 — 246.2 N (21.9 — 25.1 kgf, 48.3 — 55.3 lb)/ 45.0 mm (1.772 in)
	526.6 — 581.6 N (53.7 — 59.3 kgf, 118.4 — 130.8 lb)/34.7 mm (1.366 in)

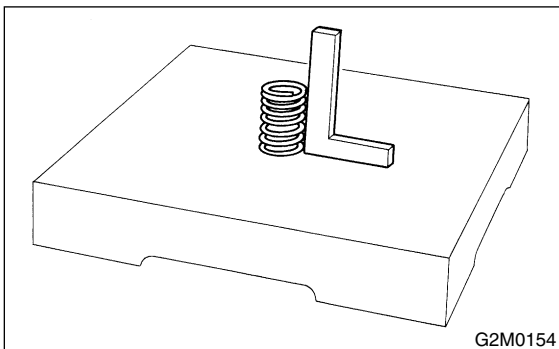

## 2. INTAKE AND EXHAUST VALVE OIL SEAL

S173093A1002

Replace oil seal with new one, if lip is damaged or spring out of place, or when the surfaces of intake valve and valve seat are reconditioned or intake valve guide is replaced. Use pliers to pinch and remove oil seal from valve.

- 1) Place cylinder head on ST1.
- 2) Press-fit oil seal to the specified dimension indicated in the figure using ST2.

### CAUTION:

- Apply engine oil to oil seal before press-fitting.
- When press-fitting oil seal, do not use hammer or strike in.
- Differentiate between intake valve oil seal and exhaust valve oil seal by noting their difference in color.

ST1 498267800 CYLINDER HEAD TABLE

ST2 498857100 VALVE OIL SEAL GUIDE

### Color of rubber part:

*Intake [Black]*

*Exhaust [Brown]*

### Color of spring part:

*Intake [Silver]*

*Exhaust [Silver]*

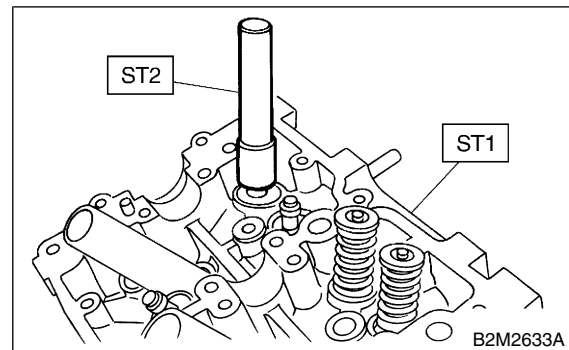

## F: ADJUSTMENT

S173093A01

### 1. CYLINDER HEAD

S173093A0101

1) Make sure that no crack or other damage exists. In addition to visual inspection, inspect important areas by means of red lead check.

Also make sure that gasket installing surface shows no trace of gas and water leaks.

2) Place cylinder head on ST.

ST 498267800 CYLINDER HEAD TABLE

3) Measure the warping of the cylinder head surface that mates with crankcase using a straight edge and thickness gauge.

If the warping exceeds 0.05 mm (0.0020 in), regrind the surface with a surface grinder.

**Warping limit:**  
**0.05 mm (0.0020 in)**

**Grinding limit:**  
**0.1 mm (0.004 in)**

**Standard height of cylinder head:**  
**97.5 mm (3.839 in)**

**CAUTION:**  
 Uneven torque for the cylinder head bolts can cause warping. When reassembling, pay special attention to the torque so as to tighten evenly.

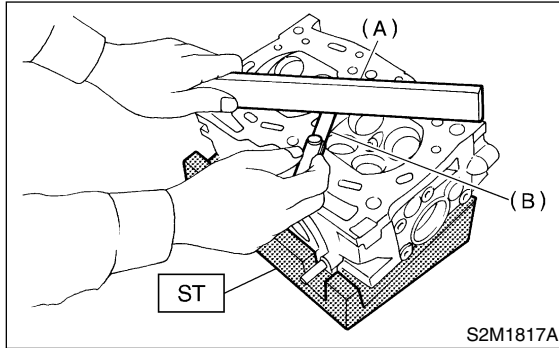

- (A) Straight edge
- (B) Thickness gauge

## 2. VALVE SEAT S173093A0102

Inspect intake and exhaust valve seats, and correct the contact surfaces with valve seat cutter if they are defective or when valve guides are replaced.

**Valve seat width: W**

**Intake**

**Standard 1.0 mm (0.039 in)**

**Limit 1.7 mm (0.067 in)**

**Exhaust**

**Standard 1.4 mm (0.055 in)**

**Limit 2.1 mm (0.083 in)**

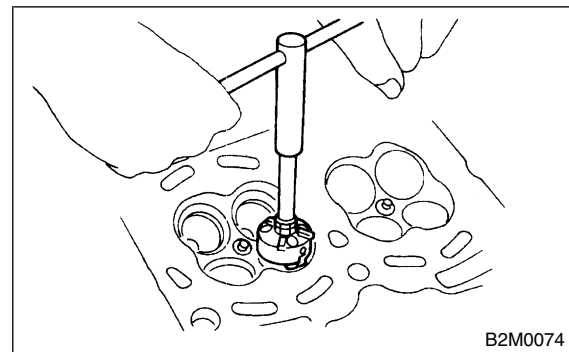
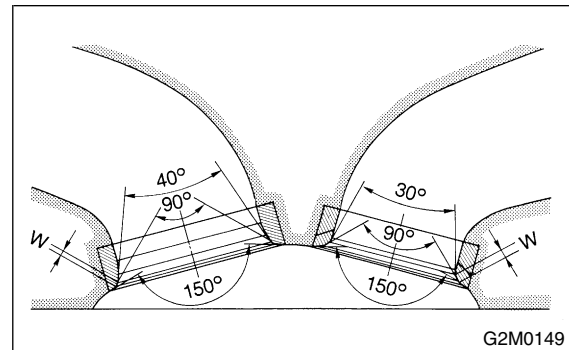

## 3. VALVE GUIDE S173093A0103

1) Check the clearance between valve guide and stem. The clearance can be checked by measuring the outside diameter of valve stem and the inside diameter of valve guide with outside and inside micrometers respectively.

# CYLINDER HEAD ASSEMBLY

Mechanical

## Clearance between the valve guide and valve stem:

### Standard

**Intake 0.035 — 0.062 mm (0.0014 — 0.0024 in)**

**Exhaust 0.040 — 0.067 mm (0.0016 — 0.0026 in)**

### Limit

**0.15 mm (0.0059 in)**

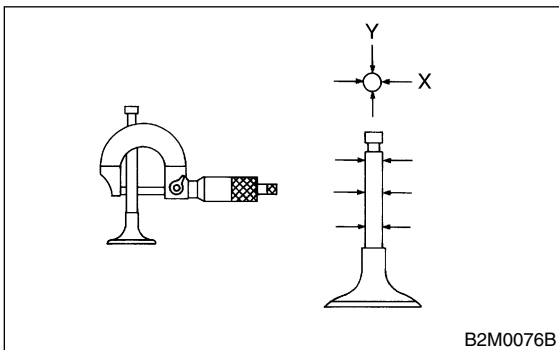
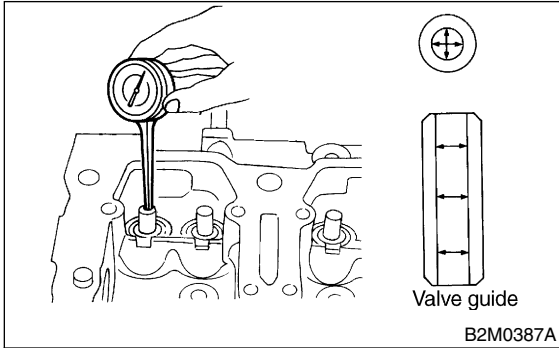

2) If the clearance between valve guide and stem exceeds the limit, replace valve guide or valve itself whichever shows greater amount of wear. See following procedure for valve guide replacement.

### Valve guide inner diameter:

**6.000 — 6.012 mm (0.2362 — 0.2367 in)**

### Valve stem outer diameters:

#### Intake

**5.950 — 5.965 mm (0.2343 — 0.2348 in)**

#### Exhaust

**5.945 — 5.960 mm (0.2341 — 0.2346 in)**

(1) Place cylinder head on ST1 with the combustion chamber upward so that valve guides enter the holes in ST1.

(2) Insert ST2 into valve guide and press it down to remove valve guide.

ST1 498267800 CYLINDER HEAD TABLE  
ST2 499767200 VALVE GUIDE REMOVER

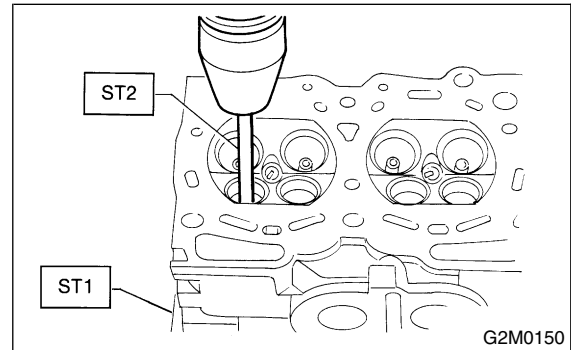

(3) Turn cylinder head upside down and place ST as shown in the figure.

### Intake side:

ST 499767700 VALVE GUIDE ADJUSTER

### Exhaust side:

ST 499767800 VALVE GUIDE ADJUSTER

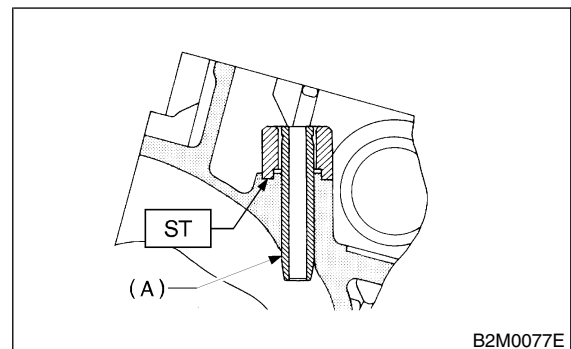

(A) Valve guide

(4) Before installing new oversize valve guide, make sure that neither scratches nor damages exist on the inside surface of the valve guide holes in cylinder head.

(5) Put new valve guide, coated with sufficient oil, in cylinder, and insert ST1 into valve guide. Press in until the valve guide upper end is flush with the upper surface of ST2.

- ST1 499767200 VALVE GUIDE REMOVER  
 Intake side:  
 ST2 499767700 VALVE GUIDE ADJUSTER  
 Exhaust side:  
 ST2 499767800 VALVE GUIDE ADJUSTER

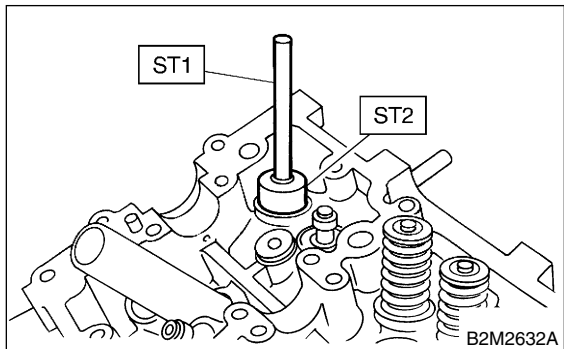

(6) Check the valve guide protrusion.

**Valve guide protrusion: L**

**Intake**

**20.0 — 20.5 mm (0.787 — 0.807 in)**

**Exhaust**

**16.5 — 17.0 mm (0.650 — 0.669 in)**

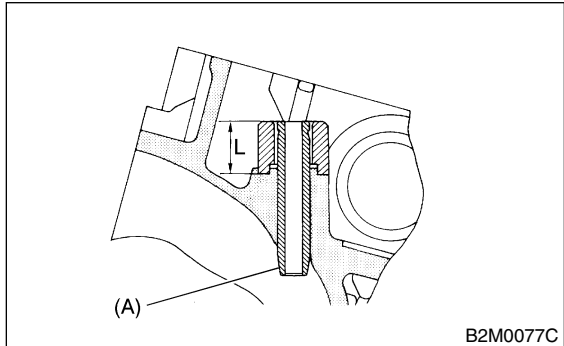

(A) Valve guide

(7) Ream the inside of valve guide with ST. Gently rotate the reamer clockwise while pressing it lightly into valve guide, and return it also rotating clockwise. After reaming, clean valve guide to remove chips.

**CAUTION:**

- Apply engine oil to the reamer when reaming.
- If the inner surface of the valve guide is torn, the edge of the reamer should be slightly ground with an oil stone.
- If the inner surface of the valve guide becomes lustrous and the reamer does not chips, use a new reamer or remedy the reamer.

ST 499767400 VALVE GUIDE REAMER

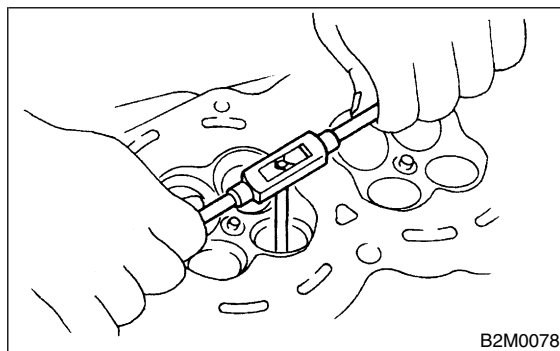

(8) Recheck the contact condition between valve and valve seat after replacing valve guide.

# CYLINDER HEAD ASSEMBLY

Mechanical

## 4. INTAKE AND EXHAUST VALVE S173093A0104

1) Inspect the flange and stem of valve, and replace if damaged, worn, or deformed, or if "H" is less than the specified limit.

**H:**

**Intake**

**Standard 1.0 mm (0.039 in)**

**Limit 0.6 mm (0.024 in)**

**Exhaust**

**Standard 1.2 mm (0.047 in)**

**Limit 0.6 mm (0.024 in)**

**Valve overall length:**

**Intake**

**120.6 mm (4.75 in)**

**Exhaust**

**121.7 mm (4.79 in)**

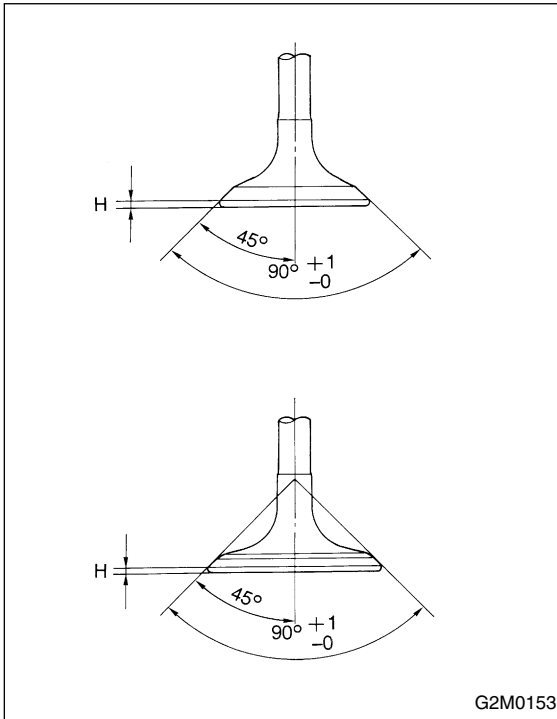

2) Put a small amount of grinding compound on the seat surface and lap the valve and seat surface. <Ref. to ME-63, VALVE SEAT, ADJUSTMENT, Cylinder Head Assembly.> Install a new intake valve oil seal after lapping.