

2. Accelerator Pedal S177005

A: REMOVAL S177005A18

- 1) Disconnect ground cable from battery.
- 2) Remove lock nut from accelerator cable bracket.
- 3) Separate accelerator cable from bracket.
- 4) Remove accelerator cable end from throttle cam.
- 5) Disconnect accelerator cable from throttle body.

CAUTION:

Be careful not to kink accelerator cable.

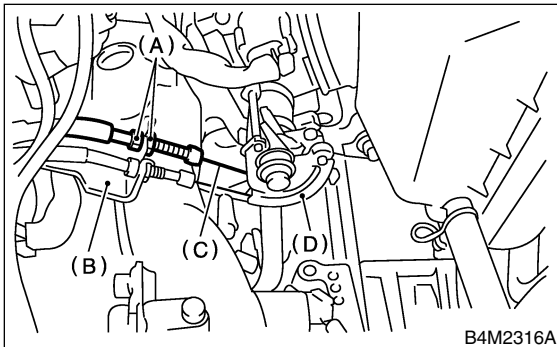

- (A) Lock nut
- (B) Accelerator cable bracket
- (C) Accelerator cable
- (D) Throttle cam

- 6) Remove clip inside engine compartment.

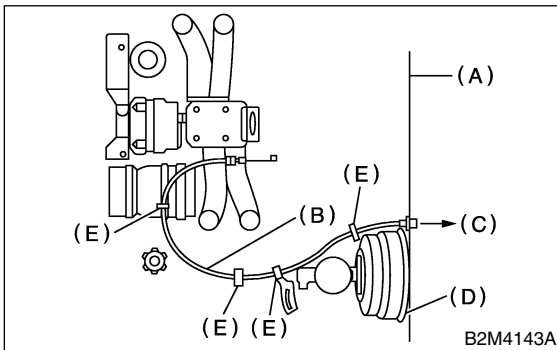

- (A) Toe board
- (B) Accelerator cable
- (C) To accelerator
- (D) Brake booster
- (E) Clip

- 7) Remove instrument panel lower cover from instrument panel, and connector.
- 8) Remove brake and clutch pedal bracket. (MT model) <Ref. to BR-41, REMOVAL, Brake Pedal.>

- 9) Remove accelerator pedal connecting bolt from accelerator pedal bracket.

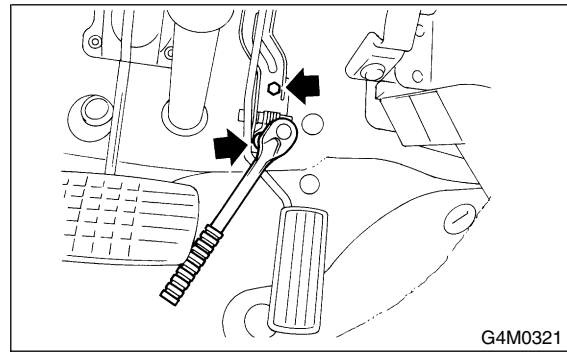

- 10) Disconnect grommet from toe board.

NOTE:

From inside compartment, push grommet (A) into hole.

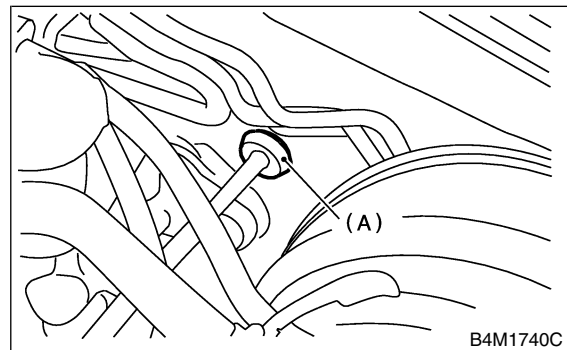

- 11) Pull out the cable from the toe board hole.
- 12) Disconnect accelerator cable bushing from accelerator pedal lever.

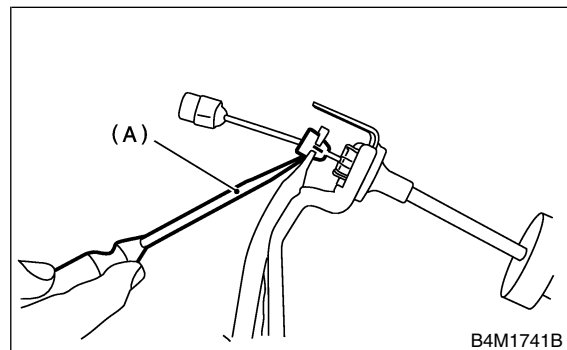

- (A) Slot type screwdriver

ACCELERATOR PEDAL

Speed Control Systems

13) Disconnect accelerator cable stopper (A) from bracket.

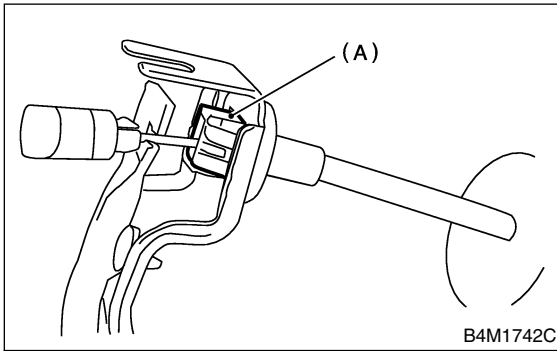

14) Separate accelerator cable and bracket.

B: INSTALLATION S177005A11

1) Install in the reverse order of removal.

CAUTION:

- If cable clamp is damaged, replace it with a new one.
- Never fail to cover outer cable end with boot.
- Be careful not to kink accelerator cable.
- Always use new clevis pins.

2) Check pedal stroke and free play by operating accelerator pedal by hand. If it is not within specified value, adjust it by turning nut connecting accelerator cable to throttle body.

Free play at pedal pad: L
1 — 4 mm (0.04 — 0.16 in)

Stroke at pedal pad: A
50 — 55 mm (1.97 — 2.17 in)

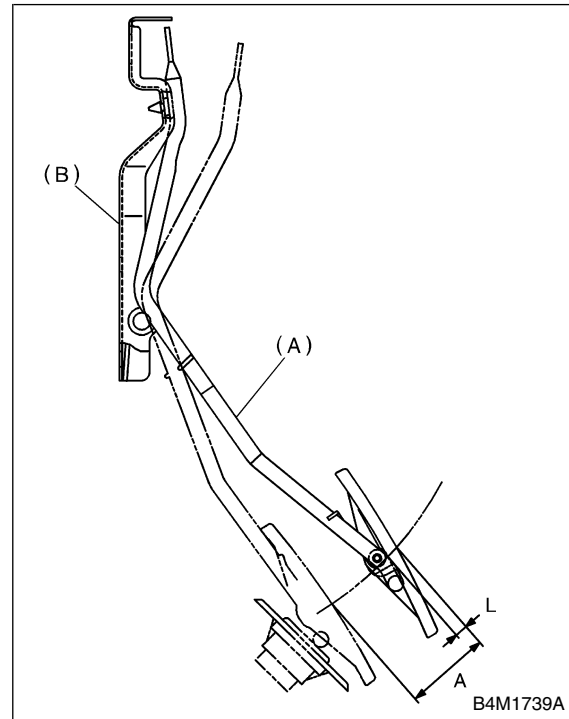

- (A) Accelerator pedal lever
(B) Accelerator pedal bracket

Accelerator cable lock nut tightening torque:
12 N·m (1.2 kgf-m, 9 ft-lb)

C: DISASSEMBLY S177005A06

- 1) Remove the clip, and then remove the accelerator pedal from the bracket.
- 2) Pull out the spring pin, and then remove the accelerator pedal from the accelerator pedal lever.

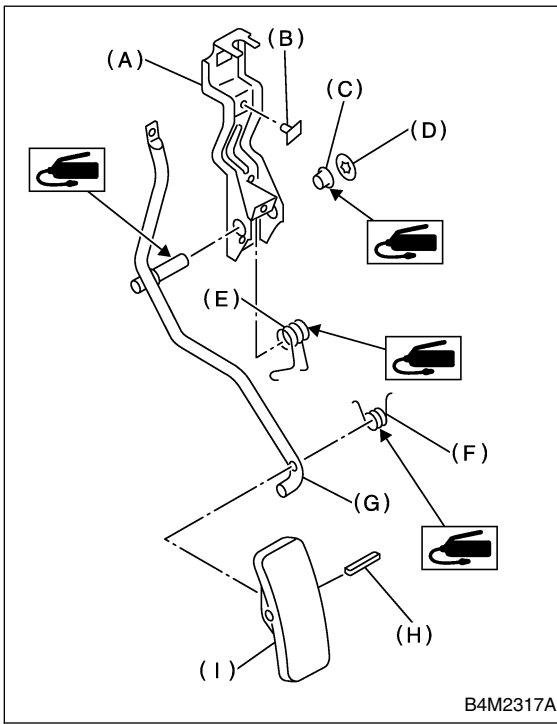

- (A) Bracket
- (B) Stopper
- (C) Bushing
- (D) Clip
- (E) Accelerator spring
- (F) Accelerator pedal spring
- (G) Accelerator pedal lever
- (H) Spring pin
- (I) Accelerator pedal

D: ASSEMBLY S177005A02

Assemble in the reverse order of disassembly.

CAUTION:
Clean and apply grease to spacer and inside bore of a accelerator pedal.

E: INSPECTION S177005A10

Lightly move pedal pad in lateral the direction to ensure pedal deflection is in specified range.

CAUTION:
If excessive deflection is noted, replace bushing and clip with new ones.

Deflection of accelerator pedal:
Service limit
5.0 mm (0.197 in) or less

