

RADIATOR MAIN FAN SYSTEM

Cooling

2. Radiator Main Fan System

S146732

A: SCHEMATIC

S146732A21

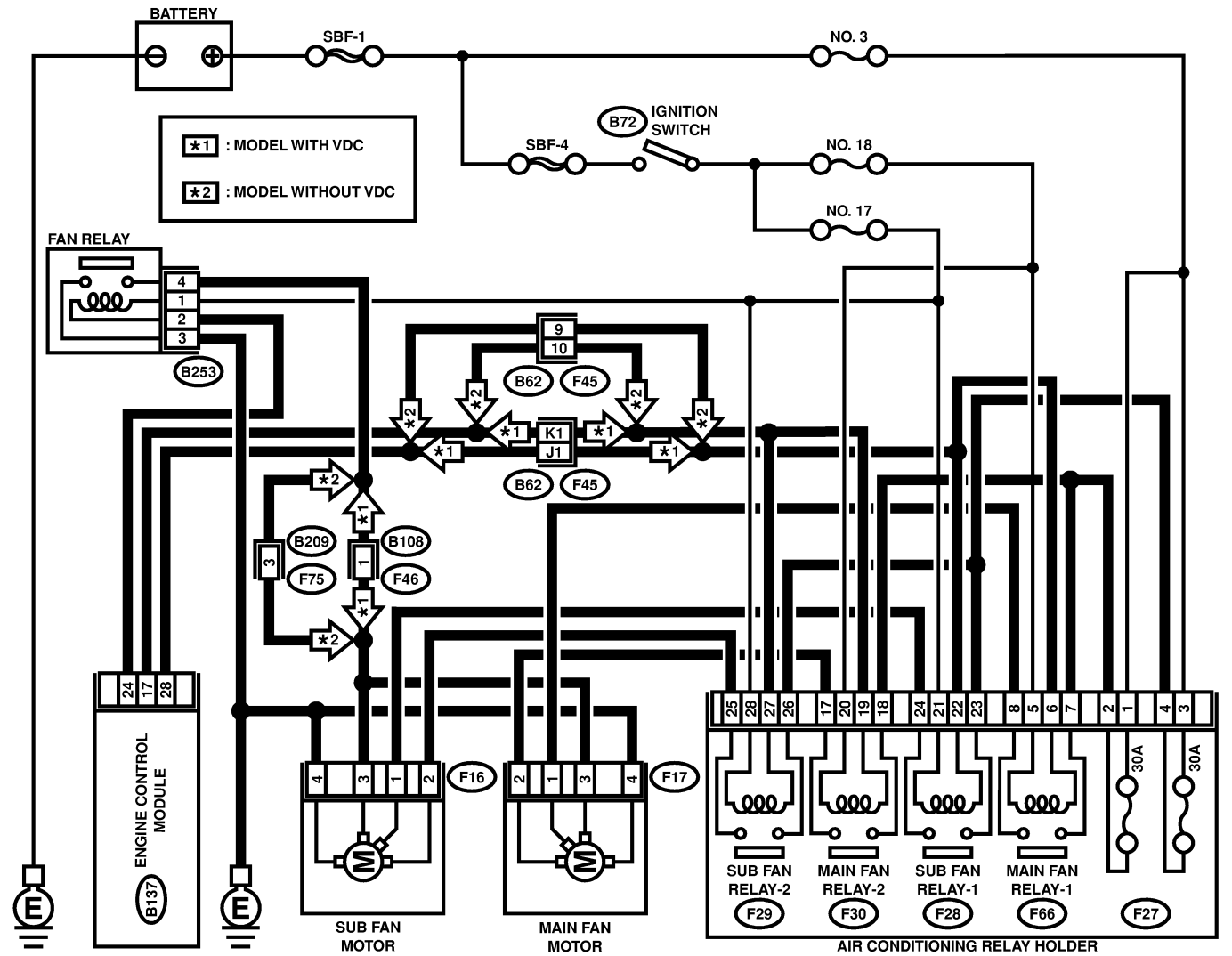

(B72) (BLUE)



(F27) (F66) (F30) (F28) (F29)

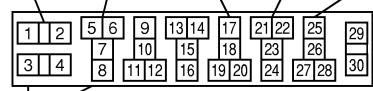

(B137)

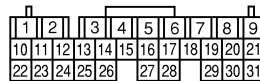

(B62) : *1

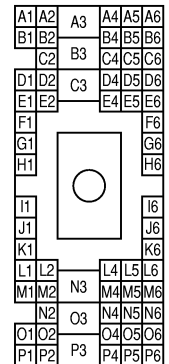

(F16)

(F17)

(F46) : *1



(B253)



(F75) : *2



(B62) : *2

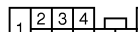

B2M4755

RADIATOR MAIN FAN SYSTEM

Cooling

B: INSPECTION

S146732A10

TROUBLE SYMPTOM:

- Radiator main fan does not rotate in low speed under the following conditions:
 - (1) Coolant temperature 95°C (203°F) or more.
 - (2) A/C switch set to OFF.
- Radiator main fan does not rotate in middle speed under the following conditions:

- (1) Coolant temperature 94°C (201°F) or less.
 - (2) A/C switch set to ON and A/C temperature at the lowest position.
- Radiator main fan does not rotate in high speed under the following conditions:
 - (1) Coolant temperature 95°C (203°F) or more.
 - (2) A/C switch set to ON and A/C temperature at the lowest position.

No.	Step	Check	Yes	No
1	CHECK OPERATION OF RADIATOR FAN. 1) Run the engine at idle (Vehicle stationary) 2) Turn the A/C switch to ON, set temperature at the lowest position. 3) Inspect while coolant temperature is 94°C (201°F) or less.	When A/C compressor is operating, does the radiator main fan rotate in middle speed?	Go to step 2.	Go to step 4.
2	CHECK OPERATION OF RADIATOR FAN. 1) Turn the A/C switch to OFF. 2) Warm the engine until coolant temperature is over 95°C (203°F).	When A/C compressor is operating, does the radiator main fan rotate in low speed?	Go to step 3.	Go to step 18.
3	CHECK OPERATION OF RADIATOR FAN. Turn the A/C switch to ON, set temperature at the lowest position.	When A/C compressor is operating, does the radiator main fan rotate in high speed?	Radiator main fan system is okay.	Go to step 31.
4	CHECK POWER SUPPLY TO MAIN FAN MOTOR. CAUTION: Be careful not to overheat engine during repair. 1) Turn ignition switch to OFF. 2) Disconnect connector from main fan motor. 3) Start the engine, keep coolant temperature below 94°C (201°F). 4) Turn the A/C switch to ON, set temperature at the lowest position. 5) Measure voltage while A/C compressor is rotating. 6) Measure voltage between main fan motor connector and chassis ground. Connector & terminal (F17) No. 2 (+) — Chassis ground (-):	Is the voltage more than 10 V?	Go to step 5.	Go to step 8.
5	CHECK GROUND CIRCUIT OF MAIN FAN MOTOR. 1) Turn ignition switch to OFF. 2) Measure resistance between main fan motor connector and chassis ground. Connector & terminal (F17) No. 4 — Chassis ground:	Is the resistance less than 5 Ω?	Go to step 6.	Repair open circuit in harness between main fan motor connector and chassis ground.
6	CHECK POOR CONTACT. Check poor contact in main fan motor connector.	Is there poor contact in main fan motor connector?	Repair poor contact in main fan motor connector.	Go to step 7.
7	CHECK MAIN FAN MOTOR. Connect battery positive (+) terminal to terminal No. 2 and negative (-) terminal to terminal No. 4 of main fan motor connector.	Does the main fan rotate?	Repair poor contact in main fan motor connector.	Replace main fan motor with a new one.

RADIATOR MAIN FAN SYSTEM

Cooling

No.	Step	Check	Yes	No
8	CHECK POWER SUPPLY TO MAIN FAN RELAY 2. 1) Turn ignition switch to OFF. 2) Remove main fan relay 2 from A/C relay holder. 3) Measure voltage between main fan relay 2 terminal and chassis ground. Connector & terminal (F30) No. 18 (+) — Chassis ground (-):	Is the voltage more than 10 V?	Go to step 9.	Go to step 10.
9	CHECK POWER SUPPLY TO MAIN FAN RELAY 2. 1) Turn ignition switch to ON. 2) Measure voltage between main fan relay 2 terminal and chassis ground. Connector & terminal (F30) No. 20 (+) — Chassis ground (-):	Is the voltage more than 10 V?	Go to step 13.	Go to step 12.
10	CHECK 30 A FUSE. 1) Remove 30 A fuse from A/C relay holder. 2) Check condition of fuse.	Is the fuse blown-out?	Replace fuse.	Go to step 11.
11	CHECK POWER SUPPLY TO A/C RELAY HOLDER 30 A FUSE TERMINAL. Measure voltage of harness between A/C relay holder 30 A fuse terminal and chassis ground. Connector & terminal (F27) No. 1 (+) — Chassis ground (-):	Is the voltage more than 10 V?	Repair open circuit in harness between 30 A fuse and main fan relay 2 terminal.	Repair open circuit in harness between main fuse box connector and 30 A fuse terminal.
12	CHECK FUSE. 1) Turn ignition switch to OFF. 2) Remove fuse No. 18 from joint box. 3) Check condition of fuse.	Is the fuse blown-out?	Replace fuse.	Repair open circuit in harness between main fan relay 2 and ignition switch.
13	CHECK MAIN FAN RELAY 2. 1) Turn ignition switch to OFF. 2) Remove main fan relay 2. 3) Measure resistance of main fan relay 2. Terminal No. 17 — No. 18:	Is the resistance more than 1 M Ω ?	Go to step 14.	Replace main fan relay 2.
14	CHECK MAIN FAN RELAY 2. 1) Connect battery to terminals No. 19 and No. 20 of main fan relay 2. 2) Measure resistance of main fan relay 2. Terminal No. 17 — No. 18:	Is the resistance less than 1 Ω ?	Go to step 15.	Replace main fan relay 2.
15	CHECK HARNESS BETWEEN MAIN FAN RELAY 2 TERMINAL AND MAIN FAN MOTOR CONNECTOR. Measure resistance of harness between main fan motor connector and main fan relay 2 terminal. Connector & terminal (F17) No. 2 — (F30) No. 17:	Is the resistance less than 1 Ω ?	Go to step 16.	Repair open circuit in harness between main fan motor connector and main fan relay 2 terminal.

RADIATOR MAIN FAN SYSTEM

Cooling

No.	Step	Check	Yes	No
16	CHECK HARNESS BETWEEN MAIN FAN RELAY 2 AND ECM. 1) Turn ignition switch to OFF. 2) Disconnect connector from ECM. 3) Measure resistance of harness between main fan relay 2 connector and ECM connector. <i>Connector & terminal</i> <i>(F30) No. 19 — (B137) No. 17:</i>	Is the resistance less than 1 Ω?	Go to step 17.	Repair open circuit in harness between main fan relay 2 and ECM.
17	CHECK POOR CONTACT. Check poor contact in connector between main fan and ECM.	Is there poor contact in connector between main fan motor and ECM.	Repair poor contact connector.	Contact with SOA (distributor) service.
18	CHECK POWER SUPPLY TO MAIN FAN MOTOR. CAUTION: Be careful not to overheat engine during repair. 1) Turn ignition switch to OFF. 2) Turn A/C switch to OFF. 3) Disconnect main fan motor connector. 4) Start the engine, and warm it up until engine coolant temperature increases over 95°C (203°F). 5) Measure voltage between main fan motor connector and chassis ground. <i>Connector & terminal</i> <i>(F17) No. 1 (+) — Chassis ground (-):</i>	Is the voltage more than 10 V?	Go to step 19.	Go to step 21.
19	CHECK POOR CONTACT. Check poor contact in main fan motor connector.	Is there poor contact in main fan motor connector?	Repair poor contact in main fan motor connector.	Go to step 20.
20	CHECK MAIN FAN MOTOR. Connect battery positive (+) terminal to terminal No. 1, and negative (-) terminal to terminal No. 4 of main fan motor connector.	Does the main fan rotate?	Repair poor contact in main fan motor connector.	Replace main fan motor with a new one.
21	CHECK POWER SUPPLY TO MAIN FAN RELAY 1. 1) Turn ignition switch to OFF. 2) Remove main fan relay 1 from A/C relay holder. 3) Measure voltage between main fan relay 1 terminal and chassis ground. <i>Connector & terminal</i> <i>(F66) No. 7 (+) — Chassis ground (-):</i>	Is the voltage more than 10 V?	Go to step 22.	Go to step 23.
22	CHECK POWER SUPPLY TO MAIN FAN RELAY 1. 1) Turn ignition switch to ON. 2) Measure voltage between main fan relay 1 terminal and chassis ground. <i>Connector & terminal</i> <i>(F66) No. 5 (+) — Chassis ground (-):</i>	Is the voltage more than 10 V?	Go to step 26.	Go to step 25.
23	CHECK 30 A FUSE. 1) Remove 30 A fuse from A/C relay holder. 2) Check condition of fuse.	Is the fuse blown-out?	Replace fuse.	Go to step 24.

RADIATOR MAIN FAN SYSTEM

Cooling

No.	Step	Check	Yes	No
24	<p>CHECK POWER SUPPLY TO A/C RELAY HOLDER 30 A FUSE TERMINAL. Measure voltage of harness between A/C relay holder 30 A fuse terminal and chassis ground.</p> <p>Connector & terminal (F27) No. 1 (+) — Chassis ground (-):</p>	Is the voltage more than 10 V?	Repair open circuit in harness between 30 A fuse and main fan relay terminal.	Repair open circuit in harness between main fuse box connector and 30 A fuse terminal.
25	<p>CHECK FUSE. 1) Turn ignition switch to OFF. 2) Remove fuse No. 18 from joint box. 3) Check condition of fuse.</p>	Is the fuse blown-out?	Replace fuse.	Repair open circuit in harness between main fan relay 1 and ignition switch.
26	<p>CHECK MAIN FAN RELAY 1. 1) Turn ignition switch to OFF. 2) Remove main fan relay 1. 3) Measure resistance of main fan relay 1.</p> <p>Terminal No. 7 — No. 8:</p>	Is the resistance more than 1 MΩ?	Go to step 27.	Replace main fan relay 1.
27	<p>CHECK MAIN FAN RELAY. 1) Connect battery to terminals No. 5 and No. 6 of main fan relay 1. 2) Measure resistance of main fan relay 1.</p> <p>Terminal No. 7 — No. 8:</p>	Is the resistance less than 1 Ω?	Go to step 28.	Replace main fan relay 1.
28	<p>CHECK HARNESS BETWEEN MAIN FAN RELAY TERMINAL AND MAIN FAN MOTOR CONNECTOR. Measure resistance of harness between main fan motor connector and main fan relay 1 terminal.</p> <p>Connector & terminal (F17) No. 1 — (F66) No. 8:</p>	Is the resistance less than 1 Ω?	Go to step 29.	Replace open circuit in harness between main fan motor connector and main fan relay 1 terminal.
29	<p>CHECK HARNESS BETWEEN MAIN FAN RELAY 1 AND ECM. 1) Turn ignition switch to OFF. 2) Disconnect connector from ECM. 3) Measure resistance of harness between main fan relay 1 connector and ECM connector.</p> <p>Connector & terminal (F66) No. 6 — (B137) No. 28:</p>	Is the resistance less than 1 Ω?	Go to step 30.	Repair open circuit in harness between main fan relay 1 and ECM.
30	<p>CHECK POOR CONTACT. Check poor contact in connector between main fan and ECM.</p>	Is there poor contact in connector between main fan motor and ECM?	Repair poor contact connector.	Contact with SOA (distributor) service.
31	<p>CHECK HARNESS BETWEEN MAIN FAN MOTOR CONNECTOR AND CHASSIS GROUND. 1) Turn ignition switch to OFF. 2) Disconnect main fan motor connector. 3) Measure resistance of harness between main fan motor connector and chassis ground.</p> <p>Connector & terminal (F17) No. 3 — Chassis ground:</p>	Is the resistance less than 5 Ω?	Go to step 32.	Go to step 33.
32	<p>CHECK POOR CONTACT. Check poor contact in main fan motor connector.</p>	Is there poor contact in main fan motor connector?	Repair poor contact in main fan motor connector.	Replace main fan motor with a new one.

RADIATOR MAIN FAN SYSTEM

Cooling

No.	Step	Check	Yes	No
33	CHECK HARNESS BETWEEN MAIN FAN AND FAN RELAY. 1) Disconnect fan relay connector. 2) Measure resistance of between main fan motor connector and fan relay connector. <i>Connector & terminal (F17) No. 3 — (B253) No. 4:</i>	Is the resistance less than 1 Ω ?	Go to step 34.	Repair open circuit between main fan motor connector and fan relay connector.
34	CHECK POWER SUPPLY TO FAN RELAY. 1) Turn ignition switch to ON. 2) Measure voltage between fan relay terminal and chassis ground. <i>Connector & terminal (B253) No. 1 (+) — Chassis ground (-):</i>	Is the voltage more than 10V?	Go to step 36.	Go to step 35.
35	CHECK FUSE. 1) Turn ignition switch to OFF. 2) Remove fuse No. 18 from joint box. 3) Check condition of fuse.	Is the fuse blown-out?	Replace fuse.	Repair open circuit in harness between main fan relay and ignition switch.
36	CHECK FAN RELAY. 1) Turn ignition switch to OFF. 2) Remove fan relay. 3) Measure resistance of fan relay. <i>Terminal No. 4 — No. 5:</i>	Is resistance more than 1 $M\Omega$?	Go to step 37.	Replace fan relay.
37	CHECK FAN RELAY. 1) Connect battery to terminals No. 1 and No. 3 of fan relay. 2) Measure resistance of fan relay. <i>Terminal No. 4 — No. 5:</i>	Is resistance less than 1 Ω ?	Go to step 38.	Replace fan relay.
38	CHECK HARNESS BETWEEN FAN RELAY TERMINAL AND CHASSIS GROUND. Measure resistance of harness between fan relay connector and chassis ground. <i>Connector & terminal (B253) No. 3 — Chassis ground:</i>	Is resistance less than 1 Ω ?	Go to step 39.	Repair open circuit in harness between fan relay connector and chassis ground.
39	CHECK HARNESS BETWEEN FAN RELAY AND ECM. 1) Turn ignition switch to OFF. 2) Disconnect connector from ECM. 3) Measure resistance of harness between fan relay and ECM connector. <i>Connector & terminal (B253) No. 2 — (B137) No. 24:</i>	Is resistance less than 1 Ω ?	Go to step 40.	Repair open circuit in harness between fan relay connector and ECM.
40	CHECK POOR CONTACT. Check poor contact in connector between fan relay and ECM.	Is there poor contact in connector between fan relay and ECM?	Repair poor contact connector.	Contact with SOA (distributor) service.

NOTE:

Inspection by SOA (distributor) service is required, because probable cause is deterioration of multiple parts.