

3. Intake Manifold S145034

A: REMOVAL S145034A18

- 1) Release fuel pressure. <Ref. to FU(H6)-50, RELEASING OF FUEL PRESSURE, OPERATION, Fuel.>
- 2) Open fuel flap lid, and remove fuel filler cap.

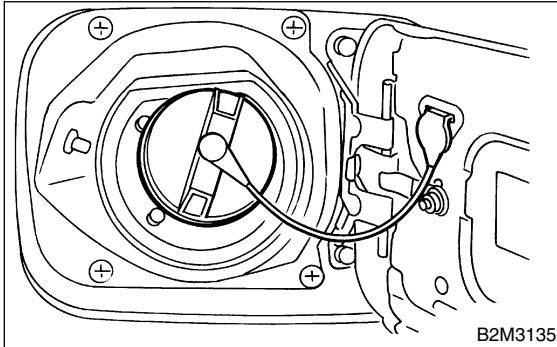

- 3) Disconnect battery ground cable.

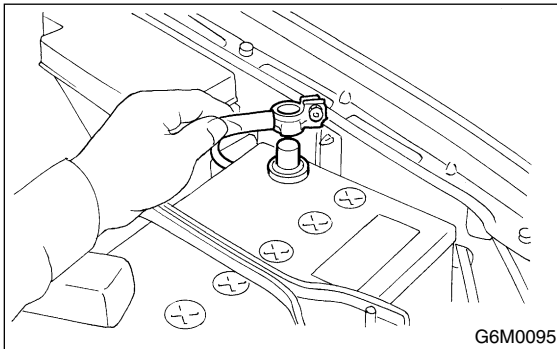

- 4) Remove air intake duct, air cleaner assembly and air intake chamber. <Ref. to IN(H6)-7, REMOVAL, Air Intake Duct.> and <Ref. to IN(H6)-5, REMOVAL, Air Cleaner.> and <Ref. to IN(H6)-6, REMOVAL, Air Intake Chamber.>
- 5) Disconnect accelerator cable (A).
- 6) Disconnect cruise control cable (B). (With cruise control model)

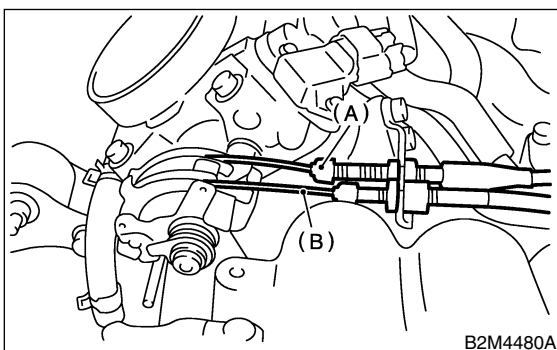

- 7) Remove power steering pump and tank from brackets.

- (1) Remove V-belt.
<Ref. to ME(H6)-29, REMOVAL, V-belt.>

- (2) Remove power steering oil pipe with bracket.

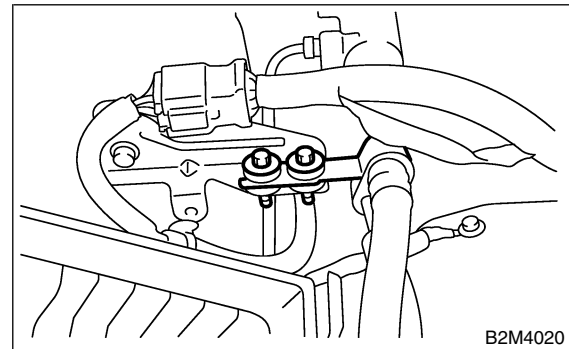

- (3) Remove bolts which install power steering pump bracket.

NOTE:
Do not separate hose and pipe from the main pump.

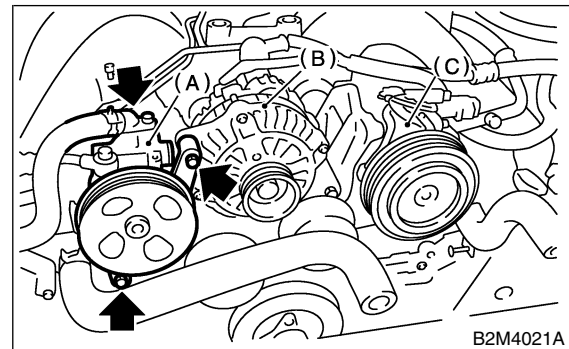

- (A) Power steering pump
- (B) Generator
- (C) A/C compressor

- (4) Disconnect power steering pump switch connector.

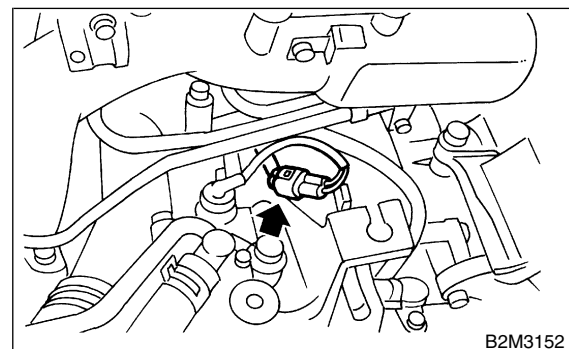

INTAKE MANIFOLD

Fuel Injection (Fuel Systems)

(5) Remove power steering tank from the bracket by pulling it upward.

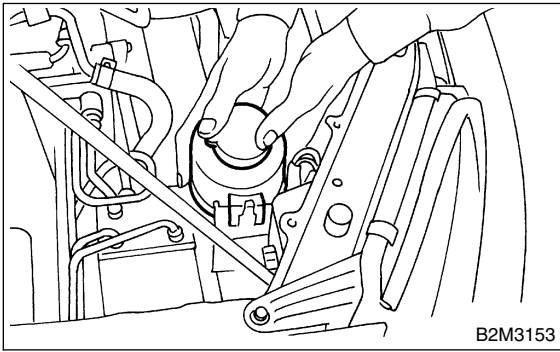

(6) Place power steering pump on the right side wheel apron.

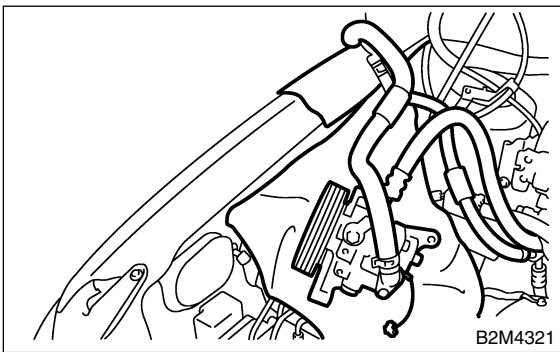

8) Remove two bolts which install washer tank on body.

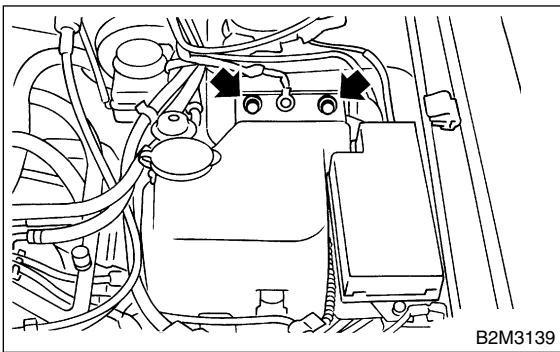

9) Disconnect connector from front window washer motor.

10) Disconnect connector from rear gate glass washer motor.

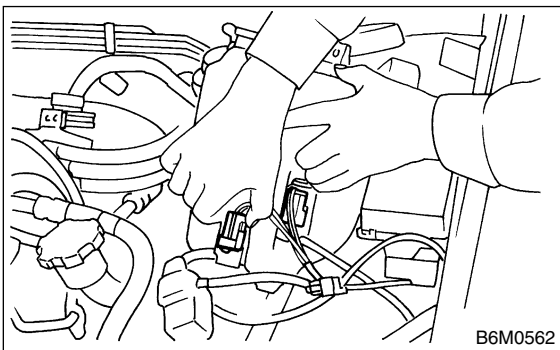

11) Disconnect rear window glass washer hose from washer motor, then plug connection with a suitable cap.

12) Move washer tank upward.

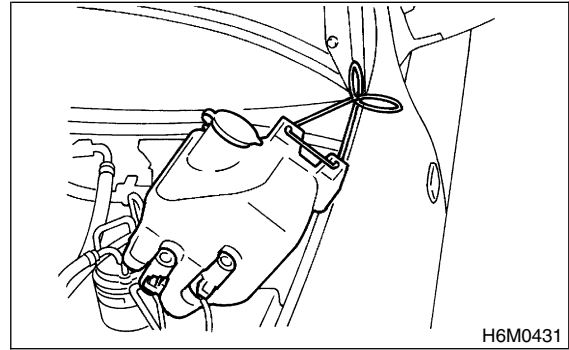

13) Disconnect PCV hoses from cylinder head cover.

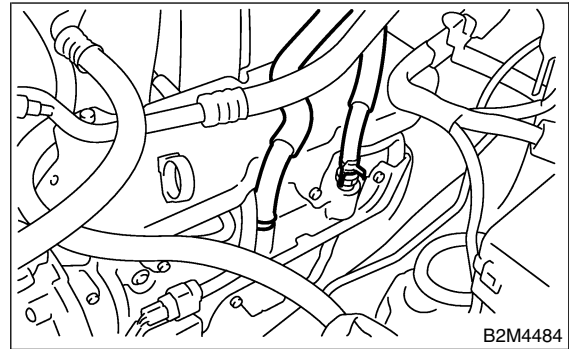

14) Disconnect engine coolant hose from throttle body.

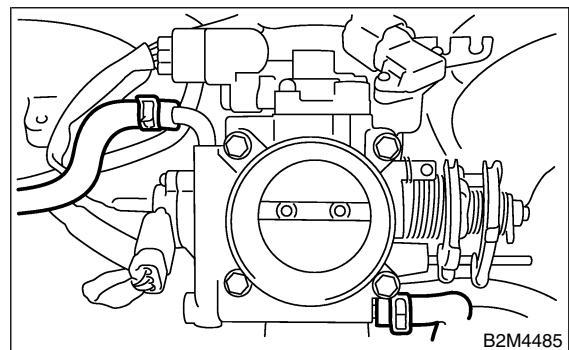

15) Disconnect brake booster hose.

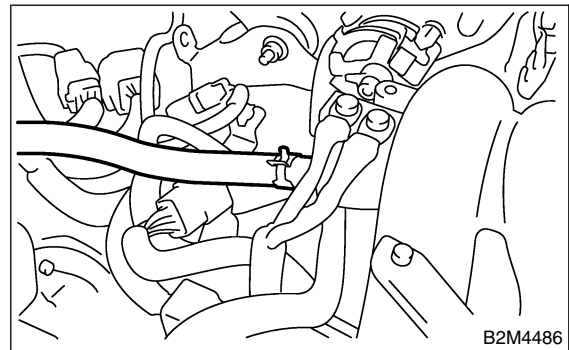

INTAKE MANIFOLD

Fuel Injection (Fuel Systems)

16) Remove EGR pipe from EGR valve.

NOTE:

Be careful not to drop gaskets.

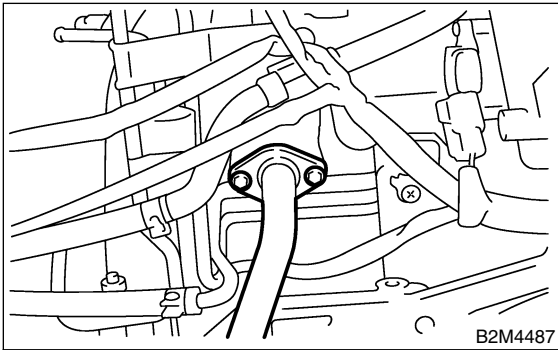

17) Disconnect engine harness connectors from bulkhead harness connectors.

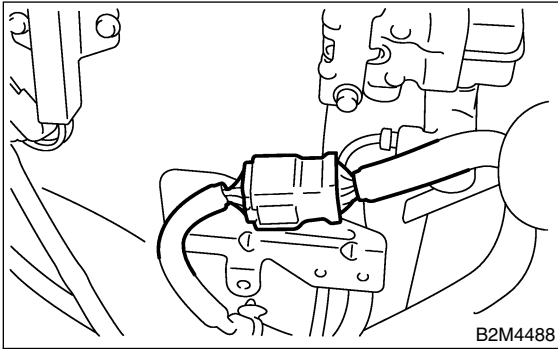

18) Disconnect engine ground cable from intake manifold.

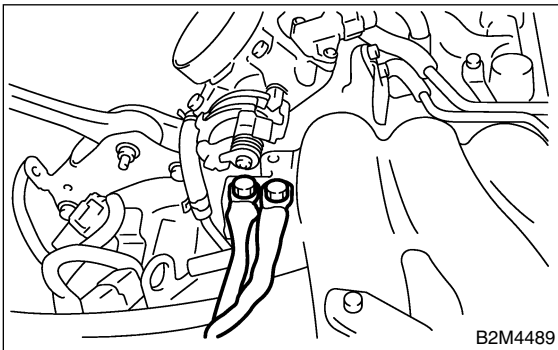

19) Disconnect fuel hoses from fuel pipes.

WARNING:

- Do not spill fuel.
- Catch fuel from hoses in a container or cloth.

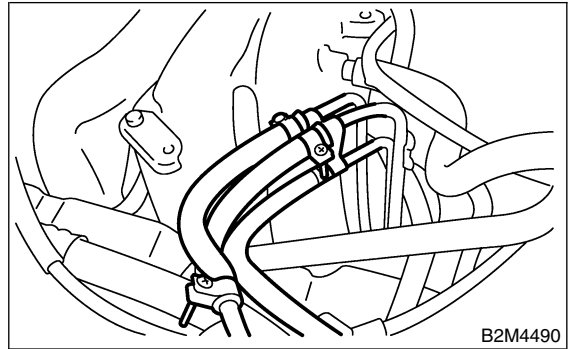

20) Remove ground cable from fuel pipe protector LH.

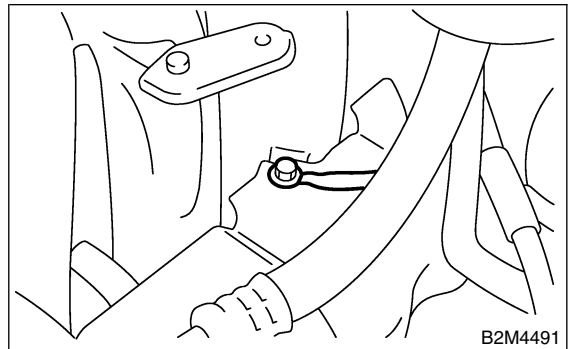

21) Remove fuel pipe protector LH.

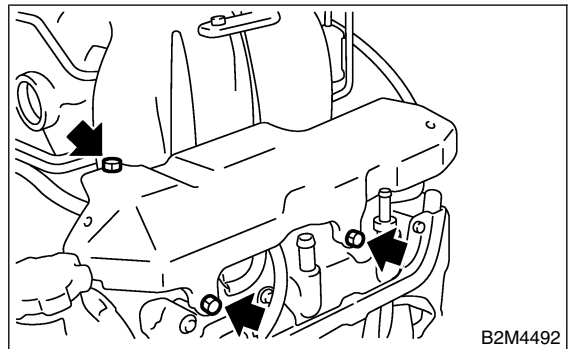

INTAKE MANIFOLD

Fuel Injection (Fuel Systems)

- 22) Disconnect air assist hose (A).
- 23) Remove the bolt (B), which holds fuel injector pipe LH onto cylinder head.

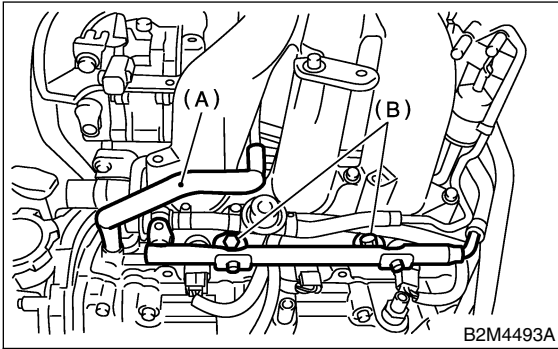

- 27) Remove bolts which hold intake manifold onto cylinder heads.

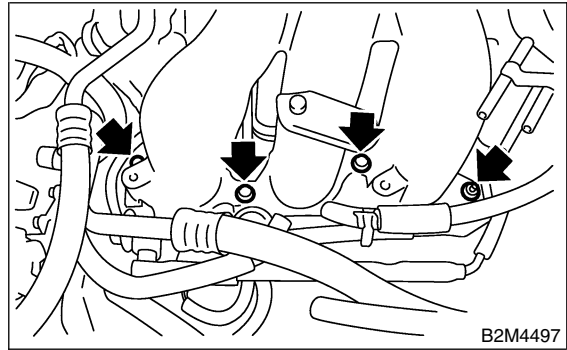

- 24) Remove ground cable from fuel pipe protector RH.

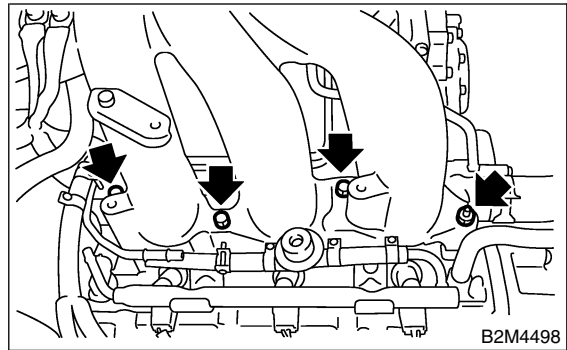
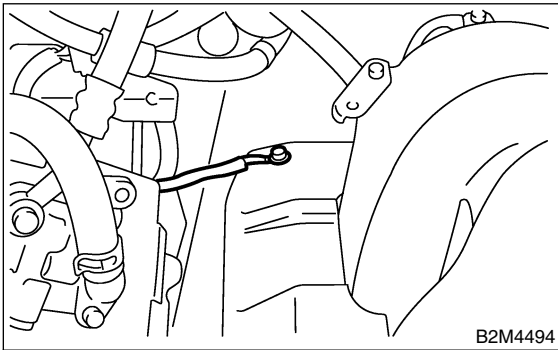

- 25) Remove fuel pipe protector RH.

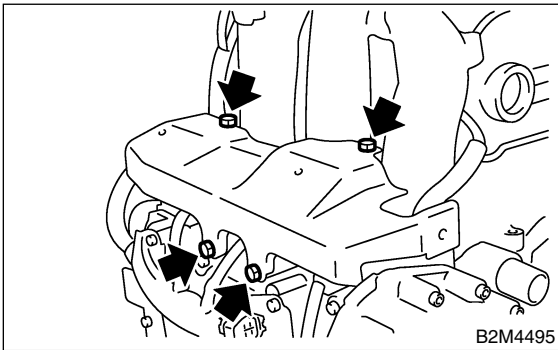

- 26) Disconnect air assist hose (A).
- Remove the bolt (B), which holds fuel injector pipe RH onto cylinder head.

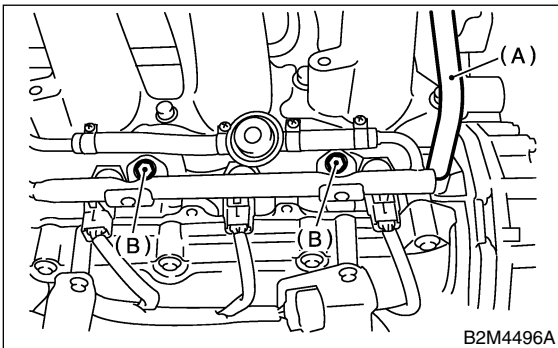

- 28) Remove intake manifold.

B: INSTALLATION S145034A11

1) Install intake manifold onto cylinder heads.

CAUTION:

Always use new gaskets.

Tightening torque:

25 N·m (2.5 kgf-m, 18.1 ft-lb)

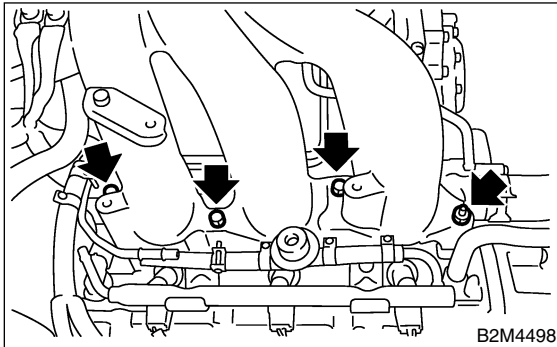
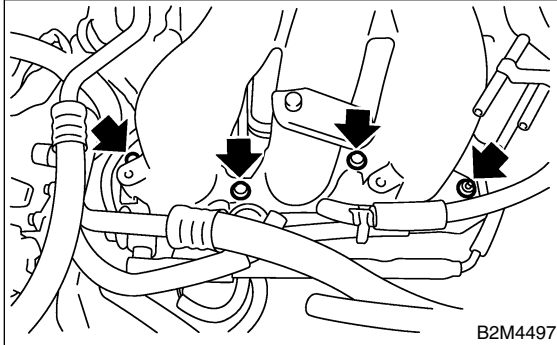

2) Install the bolt (B), which holds fuel injector pipe RH onto cylinder head.

Tightening torque:

19 N·m (1.9 kgf-m, 14 ft-lb)

3) Connect air assist hose (A).

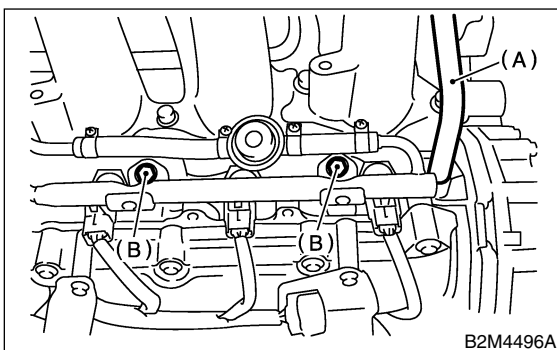

4) Install fuel pipe protector RH.

Tightening torque:

19 N·m (1.9 kgf-m, 14 ft-lb)

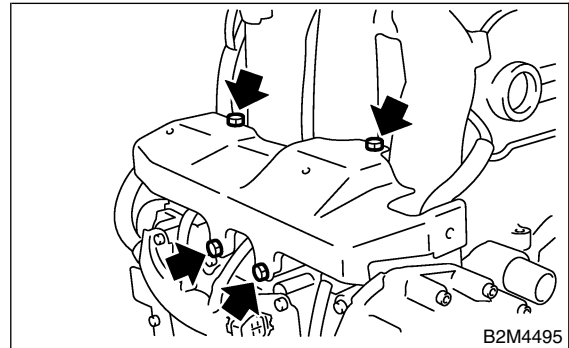

5) Install ground cable to fuel pipe protector RH.

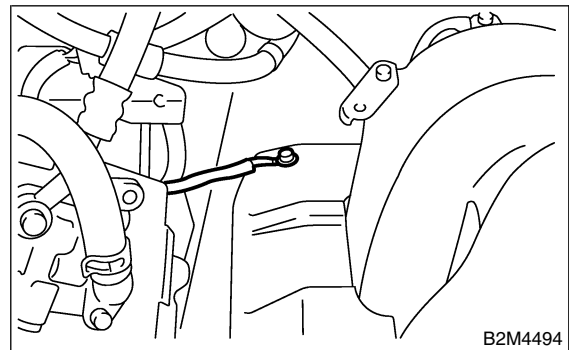

6) Install the bolt (B) which holds fuel injector pipe RH onto cylinder head.

Tightening torque:

19 N·m (1.9 kgf-m, 14 ft-lb)

7) Connect air assist hose (A).

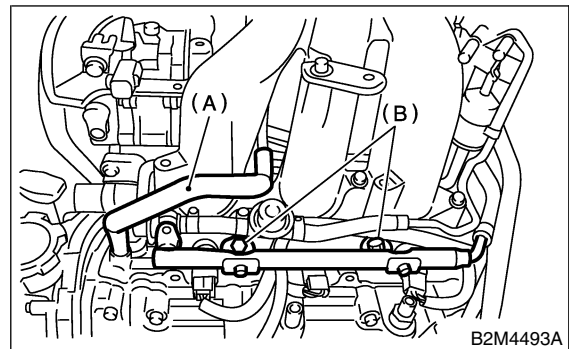

INTAKE MANIFOLD

Fuel Injection (Fuel Systems)

8) Install fuel pipe protector LH.

Tightening torque:

19 N·m (1.9 kgf·m, 14 ft·lb)

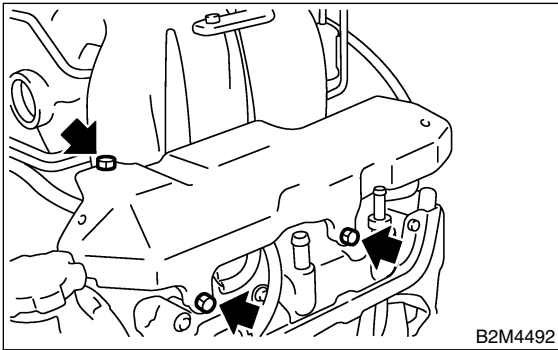

9) Install ground cable to fuel pipe protector LH.

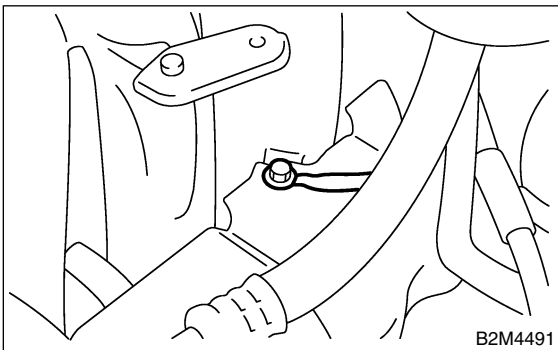

10) Install EGR pipe to EGR valve.

CAUTION:

Always use new gasket.

Tightening torque:

6.4 N·m (0.65 kgf·m, 4.7 ft·lb)

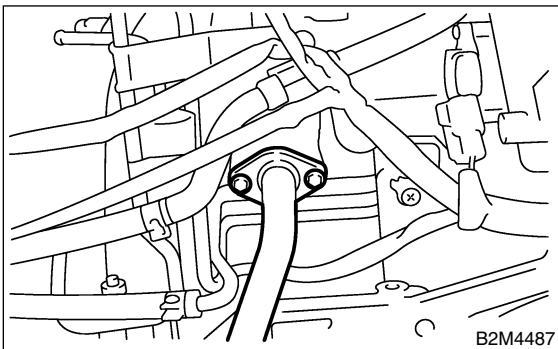

11) Connect fuel hoses.

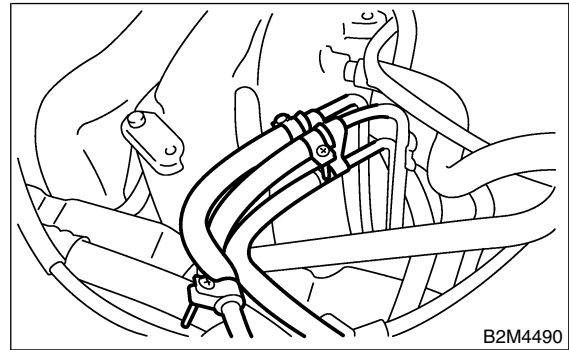

12) Connect engine ground cable to intake manifold.

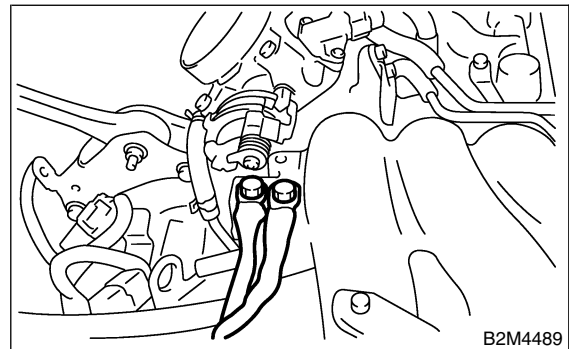

13) Connect engine harness connectors to bulk-head connectors.

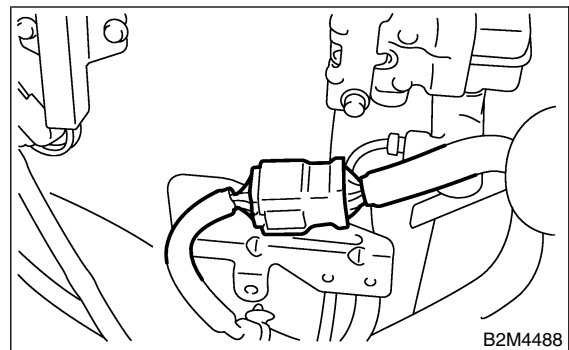

14) Connect brake booster hose.

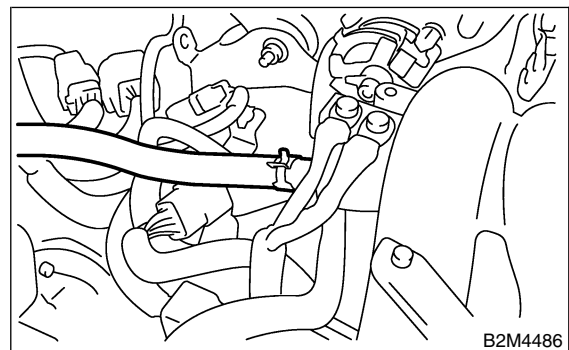

INTAKE MANIFOLD

Fuel Injection (Fuel Systems)

- 15) Connect engine coolant hose to throttle body.

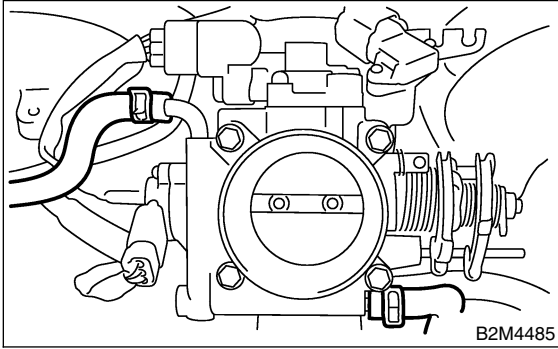

- 16) Connect PCV hose to cylinder head cover.

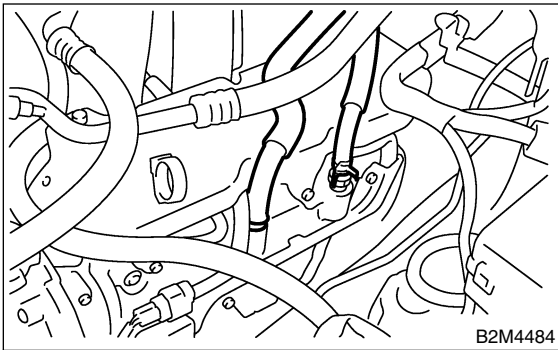

- 17) Install power steering pump and tank on brackets.

- (1) Install power steering tank on bracket.

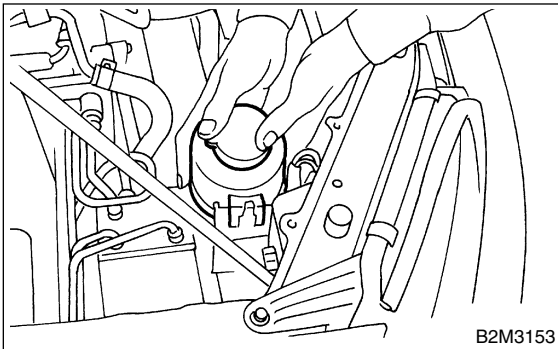

- (2) Connect connector to power steering pump switch.

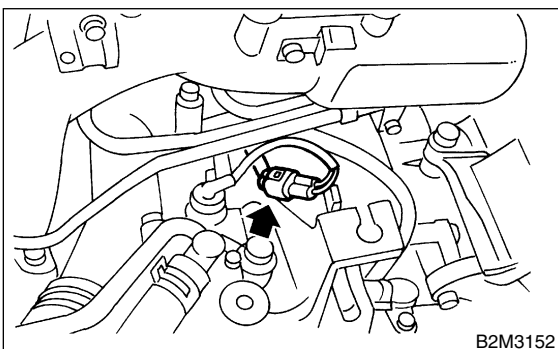

- (3) Tighten bolts which install power steering pump on bracket.

Tightening torque:

20 N·m (2.0 kgf·m, 14 ft·lb)

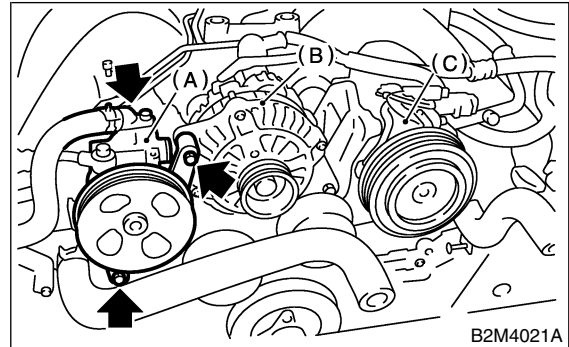

- (A) Power steering pump
(B) Generator
(C) A/C compressor

- (4) Install power steering pipes with bracket.

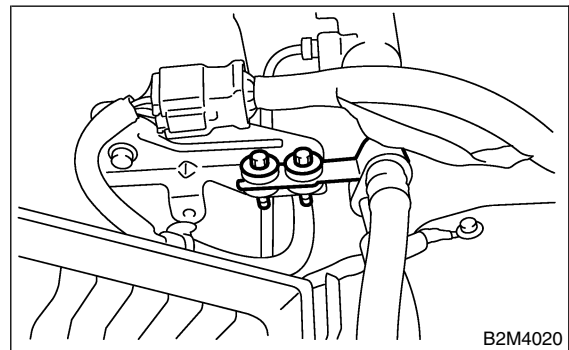

- (5) Install V-belt. <Ref. to ME(H6)-29, INSTALLATION, V-belt.>

- 18) Connect rear window washer hose to washer motor.

- 19) Connect front window washer motor connector.

- 20) Connect rear window washer motor connector.

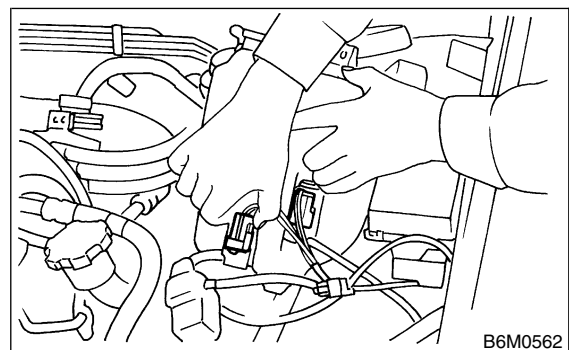

INTAKE MANIFOLD

Fuel Injection (Fuel Systems)

21) Install washer tank on body.

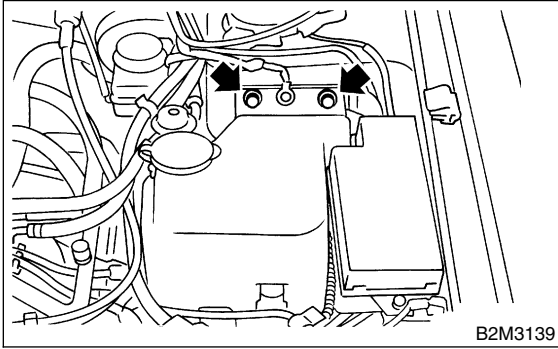

26) Connect battery ground cable.

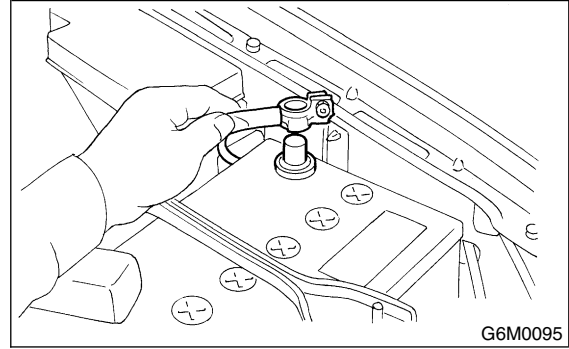

22) Connect accelerator cable (A).

23) Connect cruise control cable (B). (With cruise control models)

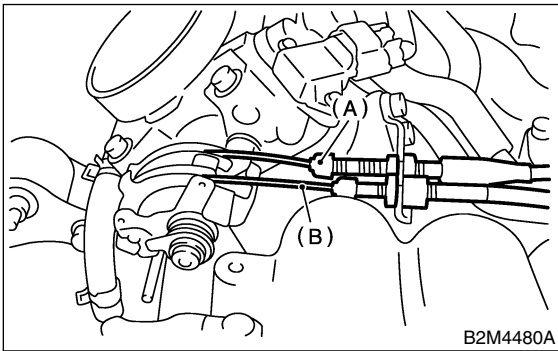

24) Install air intake duct, air cleaner and air intake chamber. <Ref. to IN(H6)-7, INSTALLATION, Air Intake Duct.> and <Ref. to IN(H6)-5, INSTALLATION, Air Cleaner.> and <Ref. to IN(H6)-6, INSTALLATION, Air Intake Chamber.>

25) Connect connector to fuel pump relay.

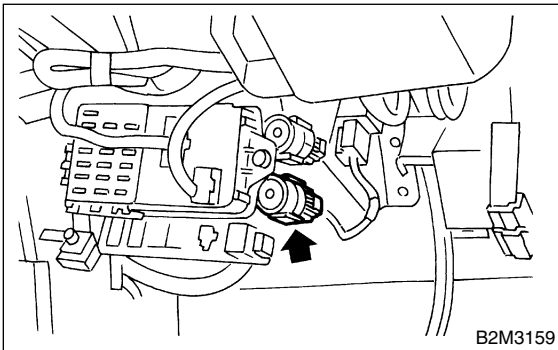

C: DISASSEMBLY

S145034A06

1) Disconnect connectors from throttle position sensor.

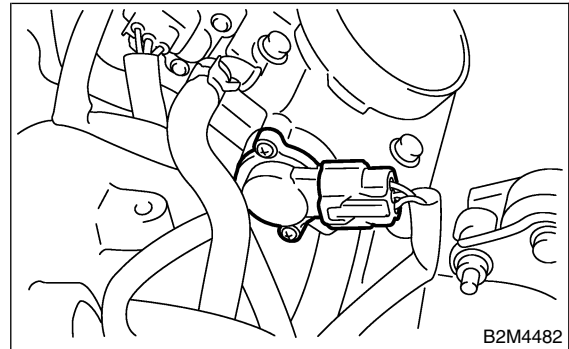

2) Disconnect connectors from intake manifold pressure sensor (B) and idle air control solenoid valve (A).

3) Disconnect air by-pass hose (C) from idle air control solenoid valve.

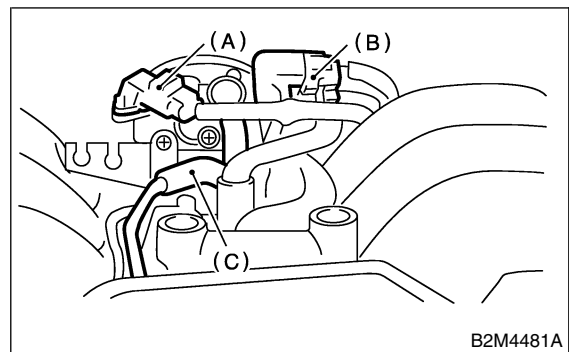

INTAKE MANIFOLD

Fuel Injection (Fuel Systems)

4) Remove throttle body.

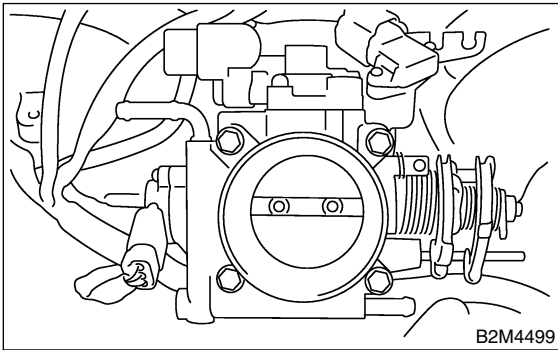

5) Remove induction valve.

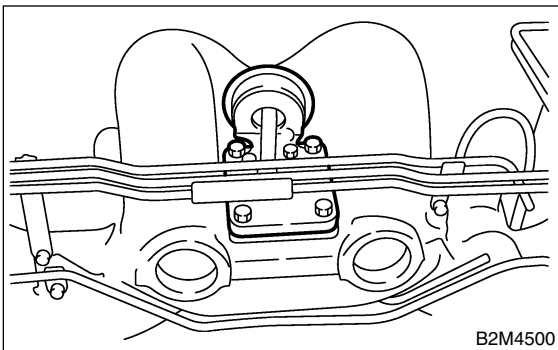

6) Disconnect connector from induction valve control solenoid.

7) Remove induction valve control solenoid.

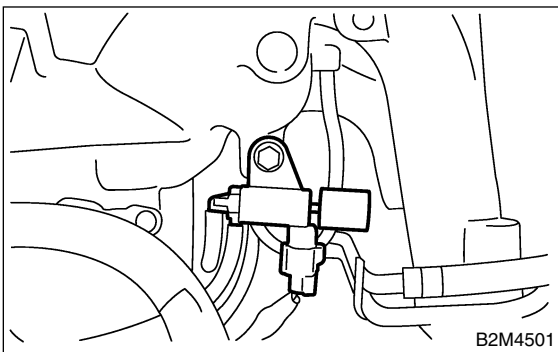

8) Disconnect connector from purge control solenoid valve.

9) Remove purge control solenoid valve.

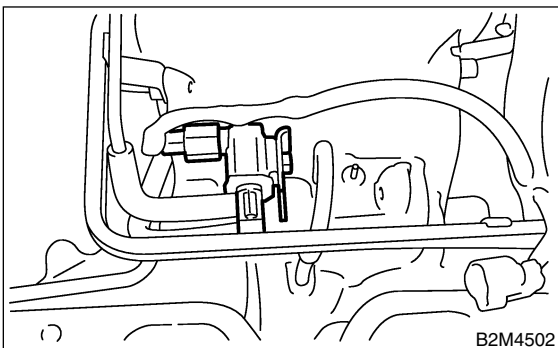

10) Disconnect connector from EGR valve.

11) Remove EGR valve.

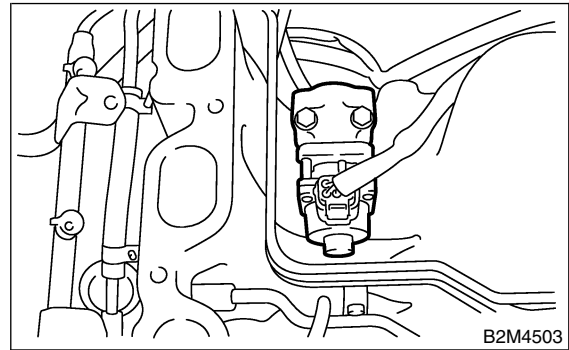

12) Remove engine harness assembly from intake manifold.

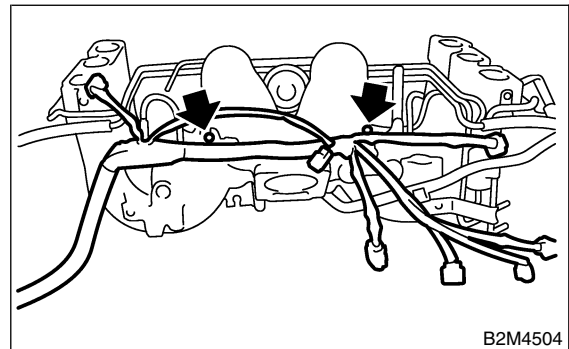

13) Remove PCV pipe from intake manifold.

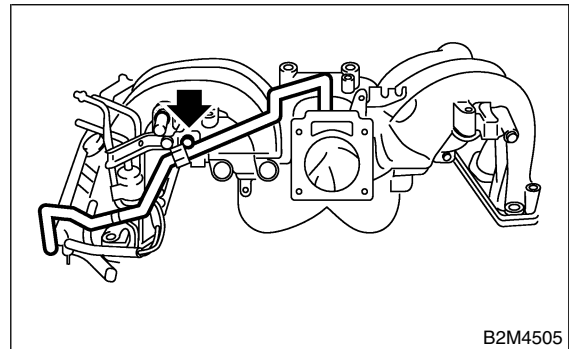

14) Remove air assist and purge pipe assembly.

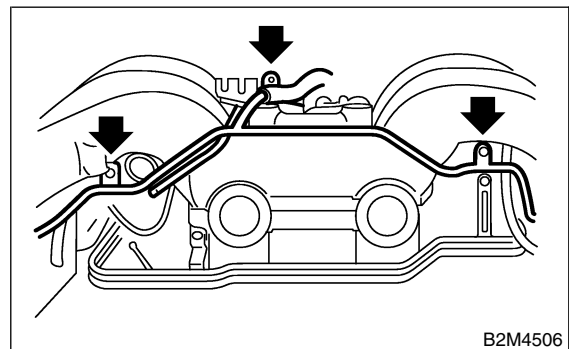

15) Disconnect pressure regulator vacuum hose (A) from intake manifold.

INTAKE MANIFOLD

Fuel Injection (Fuel Systems)

16) Remove fuel pipe and injector pipe assembly.

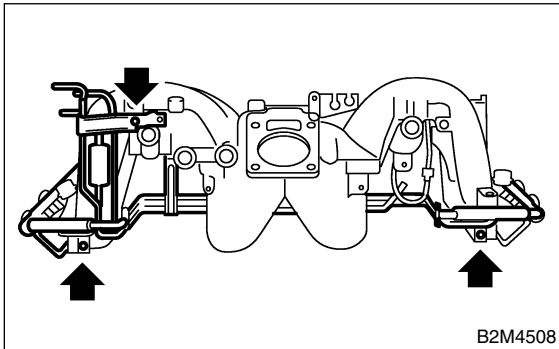
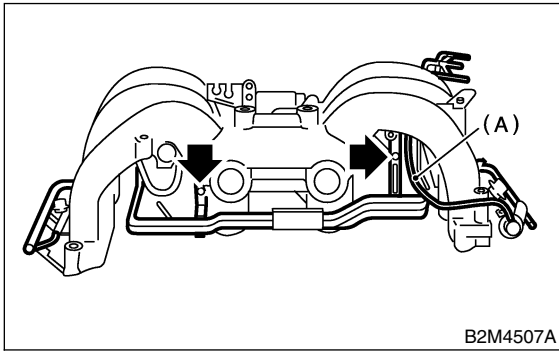

17) Remove induction valve vacuum hose from intake manifold.

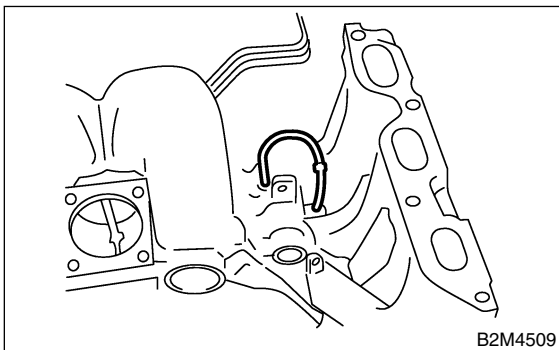

D: ASSEMBLY S145034A02

1) Intake induction valve vacuum hose to intake manifold.

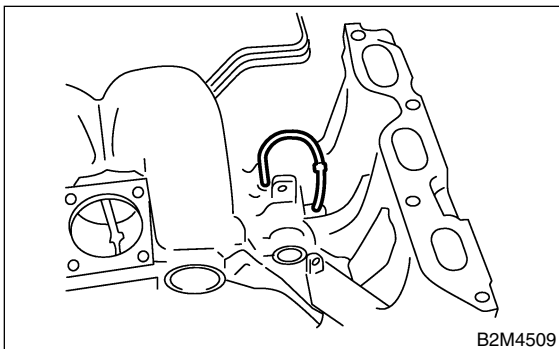

2) Install fuel pipe and injector pipe assembly.

Tightening torque:

5.0 N·m (0.51 kgf-m, 3.7 ft-lb)

3) Connect pressure regulator vacuum hose (A) to intake manifold.

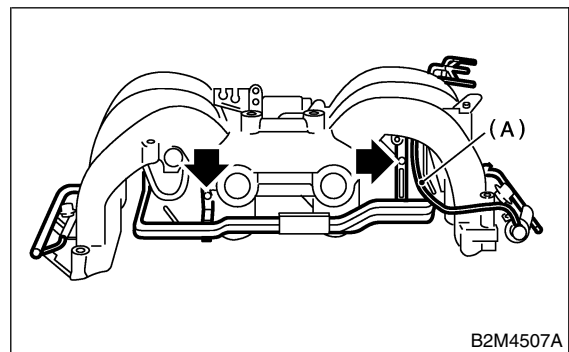
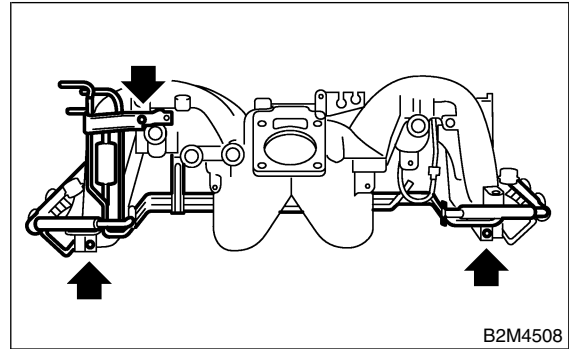

4) Install air assist and purge pipe assembly.

Tightening torque:

5.0 N·m (0.51 kgf-m, 3.7 ft-lb)

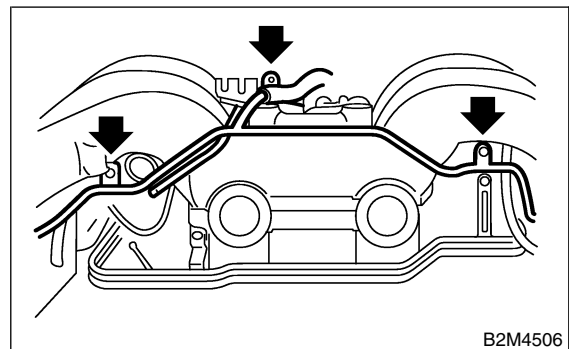

INTAKE MANIFOLD

Fuel Injection (Fuel Systems)

5) Install PCV pipe to intake manifold.

Tightening torque:

6.4 N·m (0.65 kgf-m, 4.7 ft-lb)

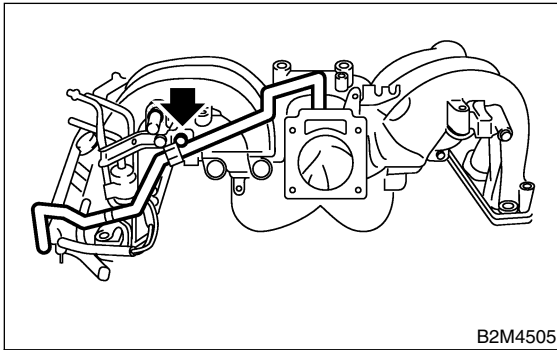

6) Install engine harness assembly to intake manifold.

Tightening torque:

5.0 N·m (0.51 kgf-m, 3.7 ft-lb)

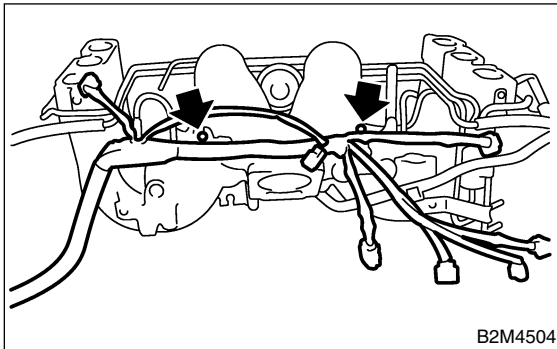

7) Install EGR valve.

Tightening torque:

19 N·m (1.9 kgf-m, 14 ft-lb)

8) Connect connector to EGR valve.

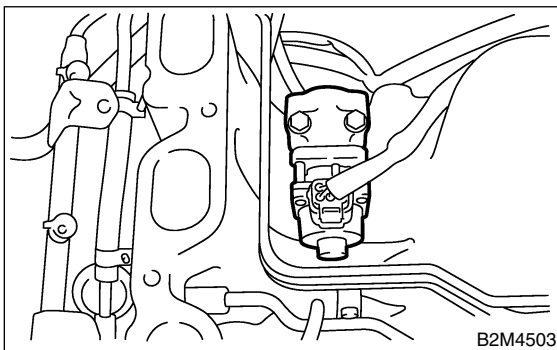

9) Install purge control solenoid valve.

Tightening torque:

19 N·m (1.9 kgf-m, 14 ft-lb)

10) Connect connector to purge control solenoid valve.

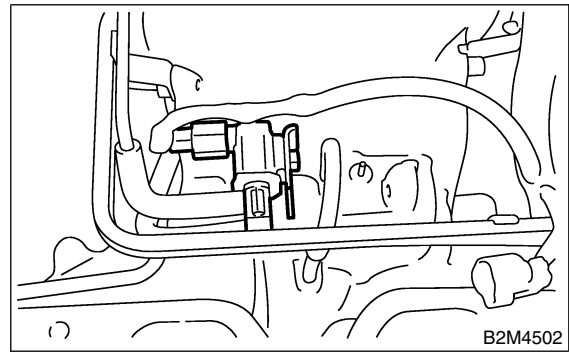

11) Connect hoses to purge control solenoid valve.

CAUTION:

Carefully connect the evaporation hoses.

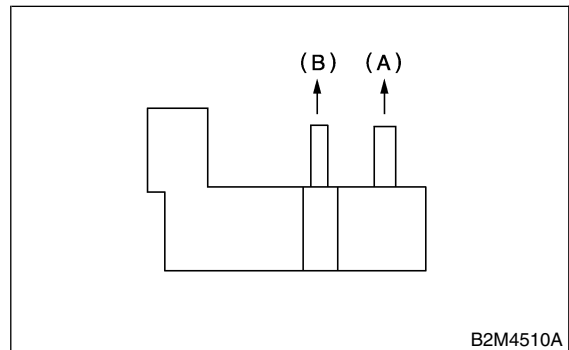

(A) To purge pipe

(B) To fuel pipe

12) Install induction valve control solenoid.

Tightening torque:

19 N·m (1.9 kgf-m, 14 ft-lb)

13) Connect connector to induction valve control solenoid.

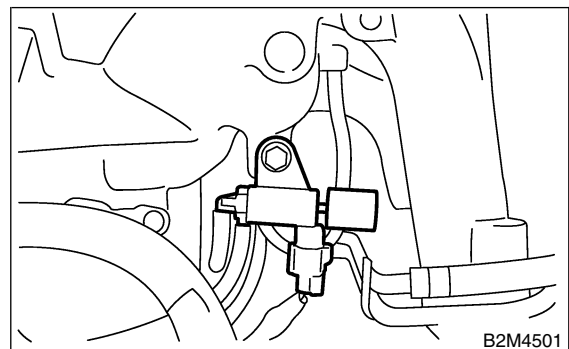

14) Install induction valve.

Tightening torque:

19 N·m (1.9 kgf-m, 14 ft-lb)

INTAKE MANIFOLD

Fuel Injection (Fuel Systems)

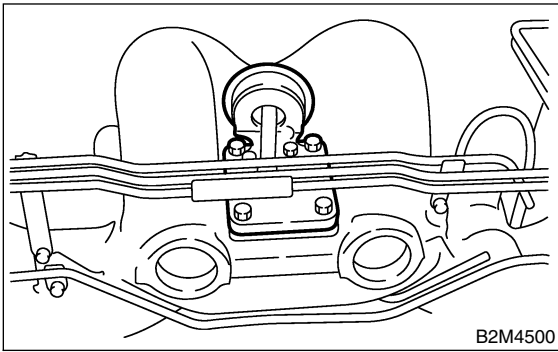

15) Connect hoses to induction valve control solenoid.

CAUTION:
Carefully connect the vacuum hoses.

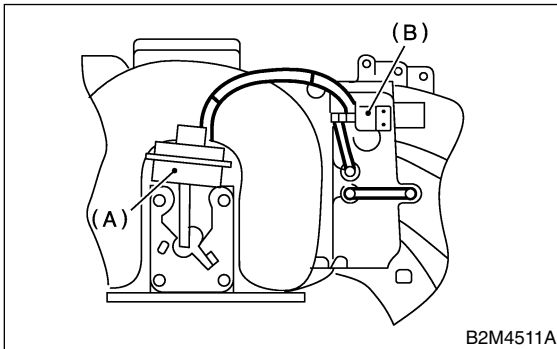

- (A) Induction valve
- (B) Induction valve control solenoid

16) Install throttle body to intake manifold.

NOTE:

Replace gasket with a new one.

Tightening torque:

22 N·m (2.2 kgf-m, 15.9 ft-lb)

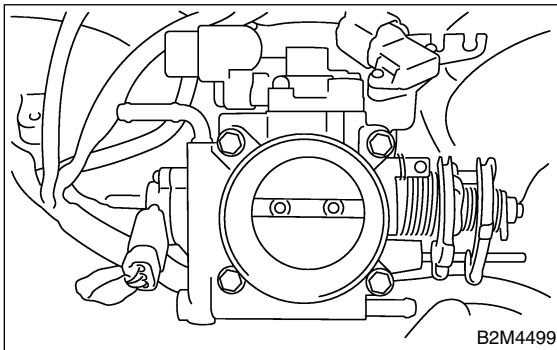

17) Connect connectors to throttle position sensor.

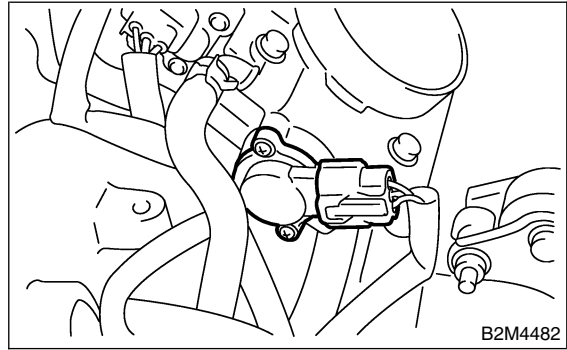

18) Connect connectors to intake manifold pressure sensor (A) and idle air control solenoid valve (B).

19) Connect air by-pass hose (C) to idle air control solenoid valve.

