

# IDLE AIR CONTROL SOLENOID VALVE

Fuel Injection (Fuel Systems)

## 11. Idle Air Control Solenoid Valve

S145056

### A: REMOVAL

S145056A18

- 1) Disconnect battery ground cable.

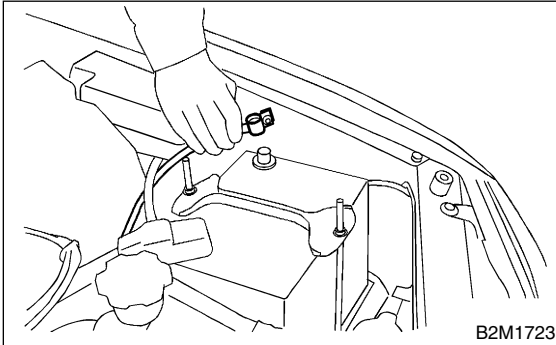

- 2) Disconnect connector (A) from idle air control solenoid valve.
- 3) Disconnect air by-pass hose (B) from idle air control solenoid valve.
- 4) Remove idle air control solenoid valve from throttle body.

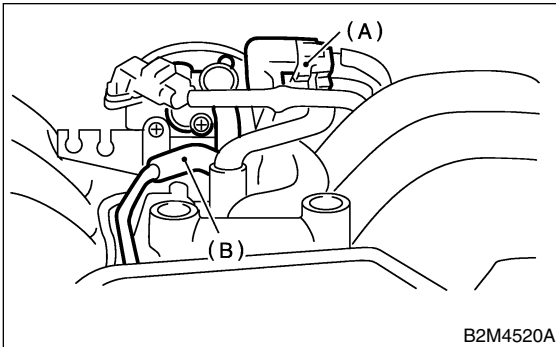

### B: INSTALLATION

S145056A11

Install in the reverse order of removal.

NOTE:

Replace gasket with a new one.

**Tightening torque:**

**2.8 N·m (0.29 kgf-m, 2.1 ft-lb)**