

## 14. Fuel Injector S145051

### A: REMOVAL S145051A18

#### 1. RH SIDE S145051A1801

- 1) Release fuel pressure.  
<Ref. to FU(H6)-50, RELEASING OF FUEL PRESSURE, Fuel.>
- 2) Open fuel flap lid, and remove fuel filler cap.

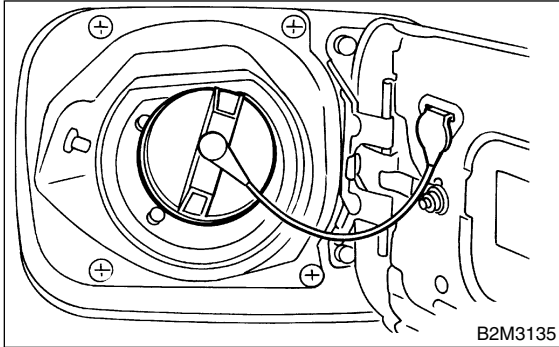

- 3) Disconnect battery ground cable.

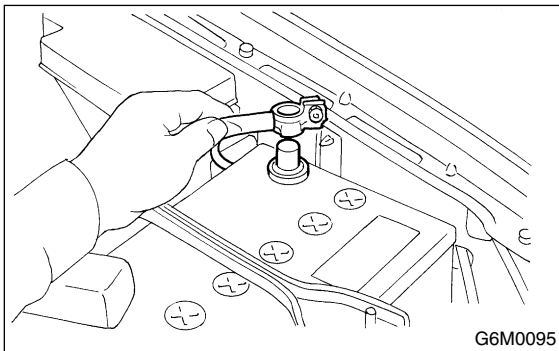

- 4) Remove air cleaner lower case. <Ref. to IN(H6)-5, REMOVAL, Air Cleaner.>
- 5) Remove power steering pump and tank from brackets.

- (1) Remove V-belt.  
<Ref. to ME(H6)-29, REMOVAL V-belt.>
- (2) Remove power steering oil pipe with bracket.

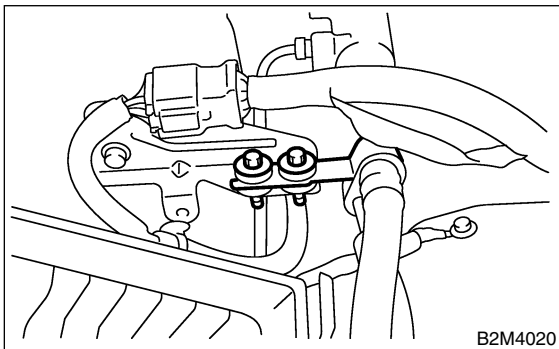

- (3) Remove bolts which install power steering pump bracket.

**CAUTION:**  
Do not separate hose and pipe from the main pump.

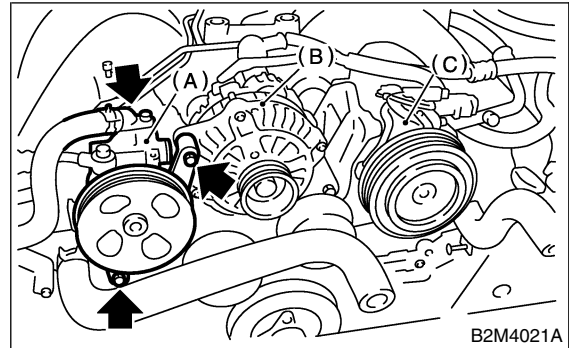

- (A) Power steering pump
- (B) Generator
- (C) A/C compressor

- (4) Disconnect power steering pump switch connector.

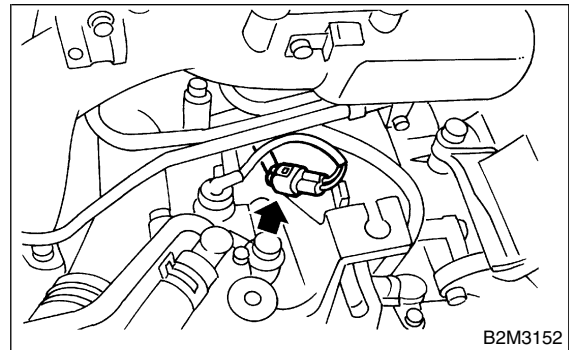

- (5) Remove power steering tank from the bracket by pulling it upward.

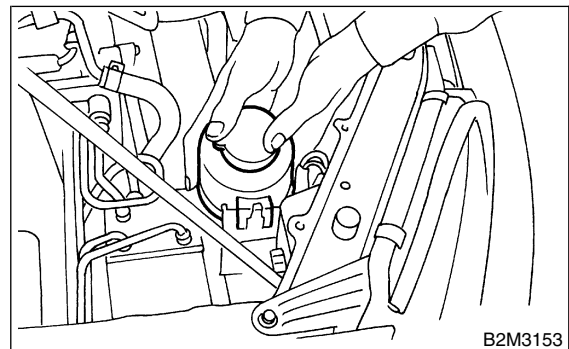

# FUEL INJECTOR

## Fuel Injection (Fuel Systems)

(6) Place power steering pump on the right side wheel apron.

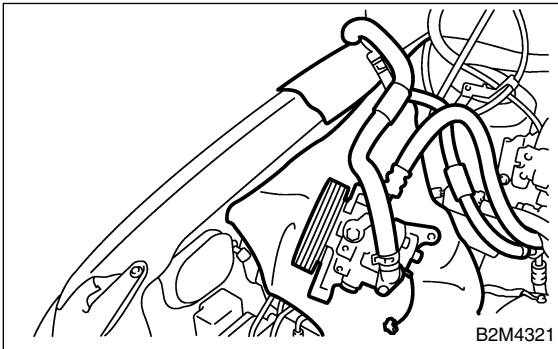

6) Remove ground cable from fuel pipe protector RH.

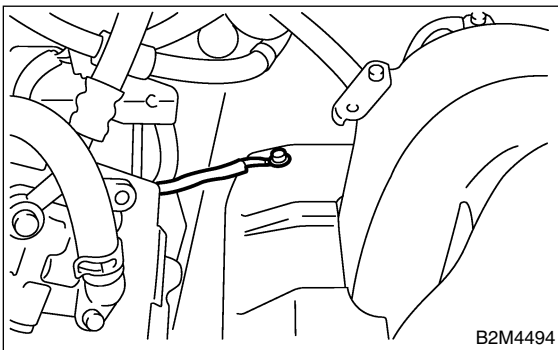

7) Remove fuel pipe protector RH.

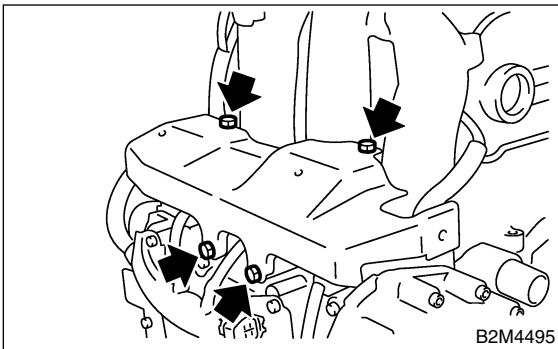

8) Disconnect connector (A) from fuel injector.  
9) Remove bolt (B) which holds injector pipe onto cylinder head.

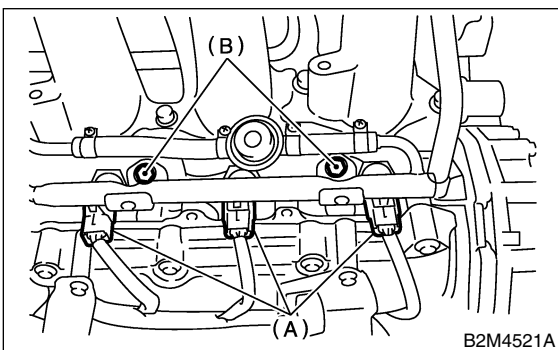

10) Remove fuel injector while lifting up fuel injector pipe.

## 2. LH SIDE S145051A1802

1) Release fuel pressure. <Ref. to FU(H6)-50, RELEASING OF FUEL PRESSURE, OPERATION, Fuel.>

2) Open fuel flap lid, and remove fuel filler cap.

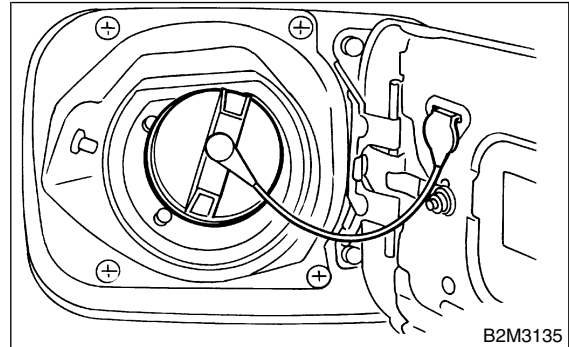

3) Disconnect battery ground cable.

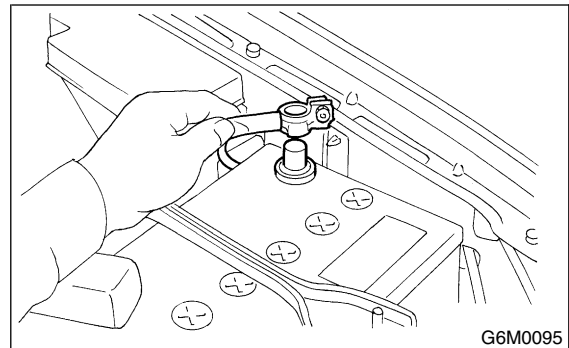

4) Remove two bolts which install washer tank on body.

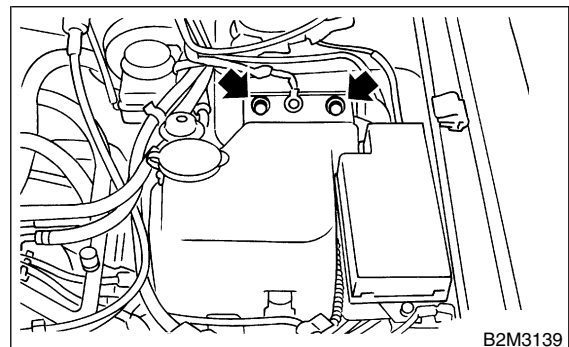

# FUEL INJECTOR

Fuel Injection (Fuel Systems)

- 5) Disconnect connector from front window washer motor.
- 6) Disconnect connector from rear gate glass washer motor.

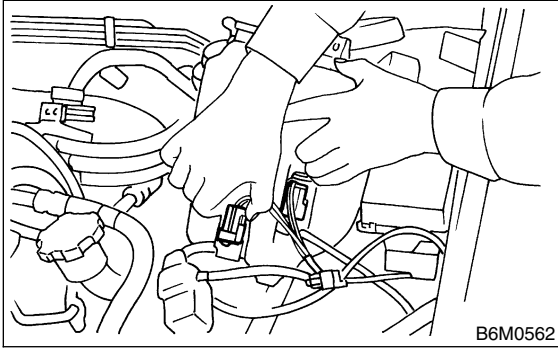

- 7) Disconnect rear window glass washer hose from washer motor, then plug connection with a suitable cap.
- 8) Move washer tank upward.

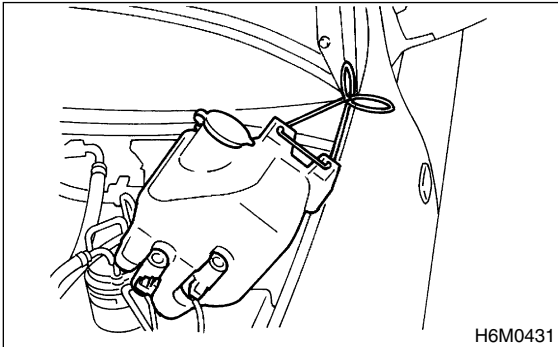

- 9) Remove ground cable from fuel pipe protector LH.

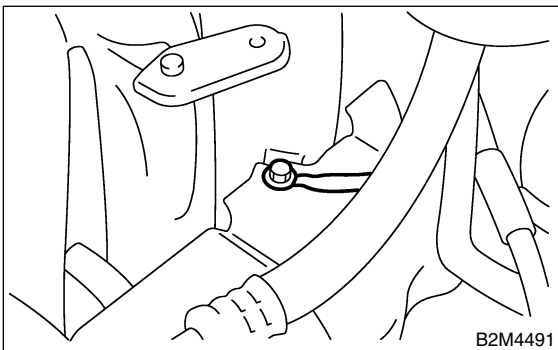

- 10) Remove fuel pipe protector LH.

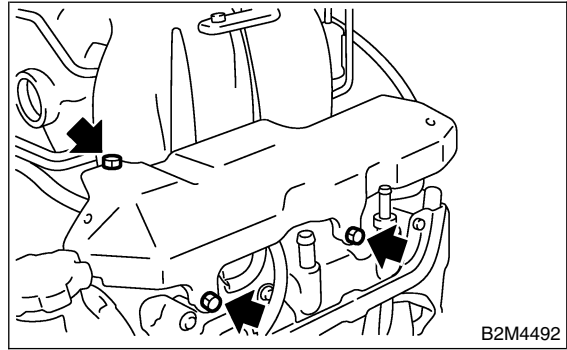

- 11) Disconnect connector (A) from fuel injector.
- 12) Remove bolt (B) which holds injector pipe onto cylinder head.

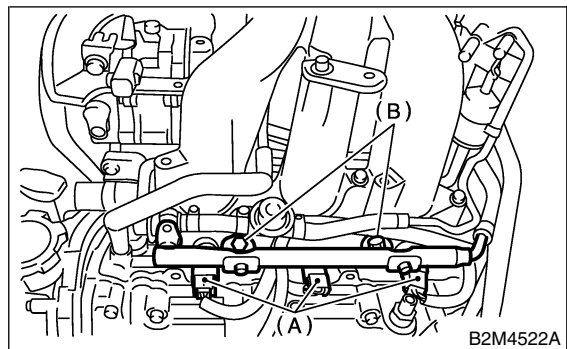

- 13) Remove fuel injector while lifting up fuel injector pipe.

# FUEL INJECTOR

Fuel Injection (Fuel Systems)

## B: INSTALLATION S145051A11

### 1. RH SIDE S145051A1101

Install in the reverse order of removal.

NOTE:

Replace O-rings and insulators with new ones.

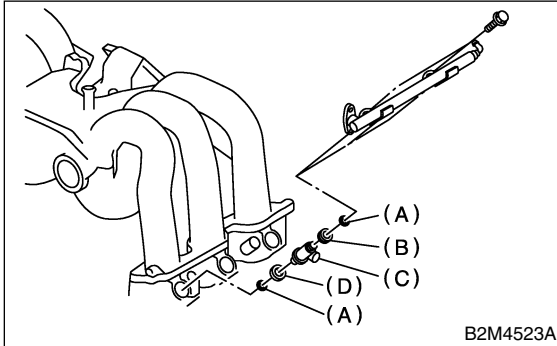

- (A) O-ring
- (B) Injection rubber
- (C) Fuel injector
- (D) Insulator

**Tightening torque:**

**19 N·m (1.9 kgf-m, 14 ft-lb)**

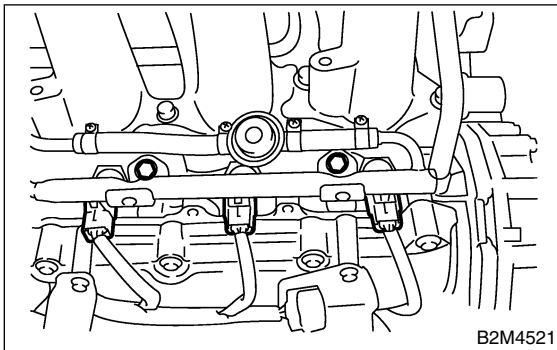

**Tightening torque:**

**19 N·m (1.9 kgf-m, 14 ft-lb)**

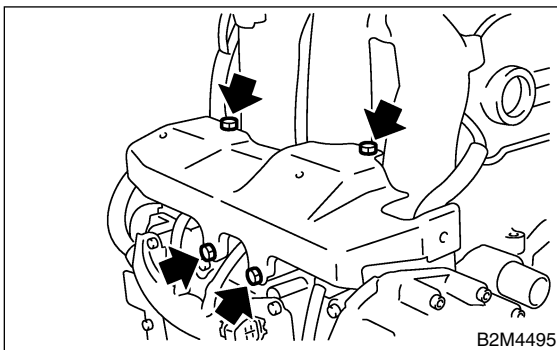

### 2. LH SIDE S145051A1102

Install in the reverse order of removal.

NOTE:

Replace O-rings and insulators with new ones.

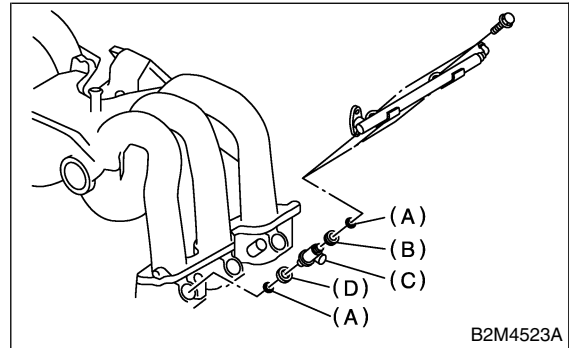

- (A) O-ring
- (B) Injection rubber
- (C) Fuel injector
- (D) Insulator

**Tightening torque:**

**19 N·m (1.9 kgf-m, 14 ft-lb)**

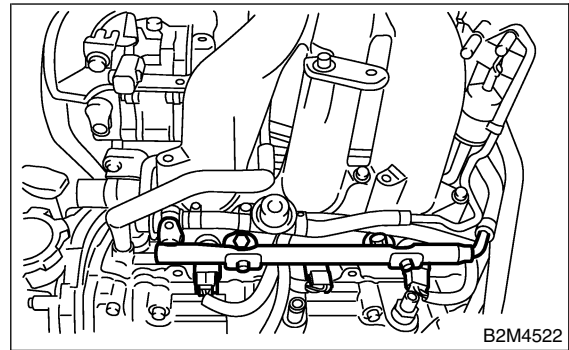

**Tightening torque:**

**19 N·m (1.9 kgf-m, 14 ft-lb)**

