

# OIL PUMP

Lubrication

## 4. Oil Pump S148070

### A: REMOVAL S148070A18

- 1) Disconnect battery ground cable.

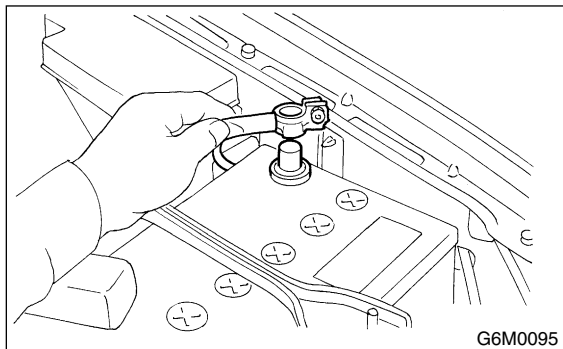

- 2) Lift-up the vehicle.
- 3) Remove under cover.

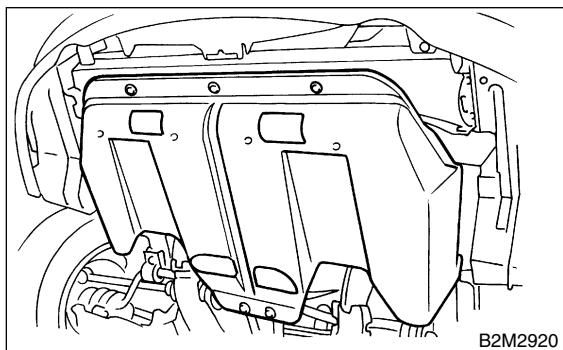

- 4) Drain coolant. <Ref. to CO(H6)-18, DRAINING OF ENGINE COOLANT, REPLACEMENT, Engine Coolant.>
- 5) Lower the vehicle.
- 6) Remove radiator. <Ref. to CO(H6)-23, REMOVAL, Radiator.>
- 7) Remove V-belt. <Ref. to ME(H6)-29, REMOVAL, V-belt.>
- 8) Remove front chain cover. <Ref. to ME(H6)-40, REMOVAL, Front Chain Cover.>
- 9) Remove timing chain. <Ref. to ME(H6)-42, REMOVAL, Timing Chain Assembly.>
- 10) Remove oil pump cover and crankshaft sprocket.

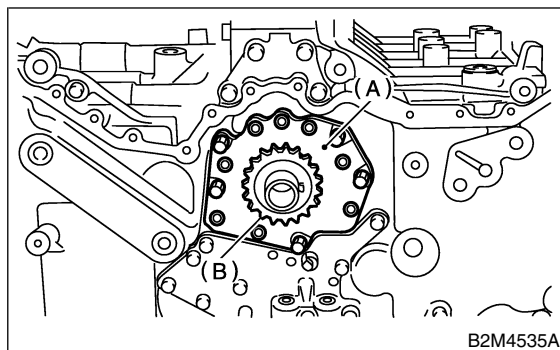

- (A) Oil pump cover
- (B) Crankshaft sprocket

- 11) Remove inner rotor and outer rotor.

### B: INSTALLATION S148070A11

- 1) Apply engine oil to the entire surface area of both inner and outer rotors.

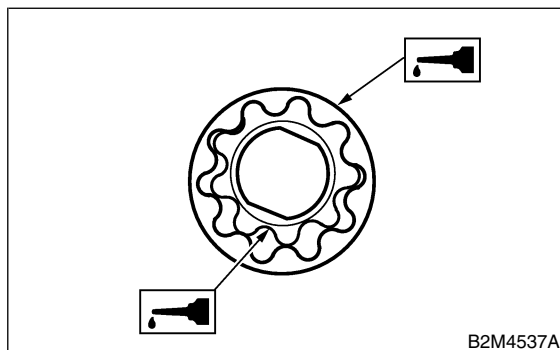

- 2) Install the inner rotor by fitting it into the groove on the crankshaft, and then assemble the outer rotor.
- 3) Install oil pump cover.
- 4) Tighten the bolts in the numerical sequence shown in the figure.

**CAUTION:**  
Make sure that bolt mounting position is correct.

**Tightening torque:**  
**6.4 N·m (0.65 kgf·m, 4.7 ft·lb)**

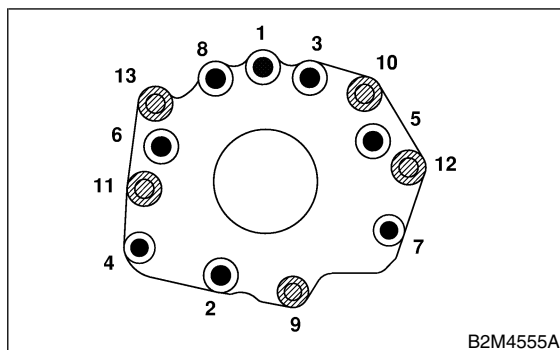

- 5) Install crank sprocket.

- 6) Install timing chain. <Ref. to ME(H6)-43, INSTALLATION, Timing Chain Assembly.>
- 7) Install front chain cover. <Ref. to ME(H6)-40, INSTALLATION, Front Chain Cover.>
- 8) Install V-belt. <Ref. to ME(H6)-29, INSTALLATION, V-belt.>
- 9) Install radiator. <Ref. to CO(H6)-24, INSTALLATION, Radiator.>
- 10) Fill coolant. <Ref. to CO(H6)-18, FILLING OF ENGINE COOLANT, REPLACEMENT, Engine Coolant.>

## C: INSPECTION S148070A10

### 1. TIP CLEARANCE S148070A1001

Measure the tip clearance of rotors. If the clearance exceeds the limit, replace rotors as a matched set.

**Tip clearance:**

**Standard**

**0.04 — 0.14 mm (0.0016 — 0.0055 in)**

**Limit**

**0.20 mm (0.0079 in)**

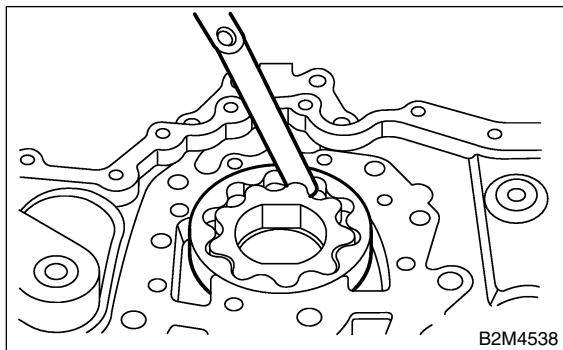

### 2. CASE CLEARANCE S148070A1002

Measure the clearance between the outer rotor and the rear chain cover rotor housing. If the clearance exceeds the limit, replace the rotor.

**Case clearance:**

**Standard**

**0.11 — 0.18 mm (0.0043 — 0.0071 in)**

**Limit**

**0.25 mm (0.0098 in)**

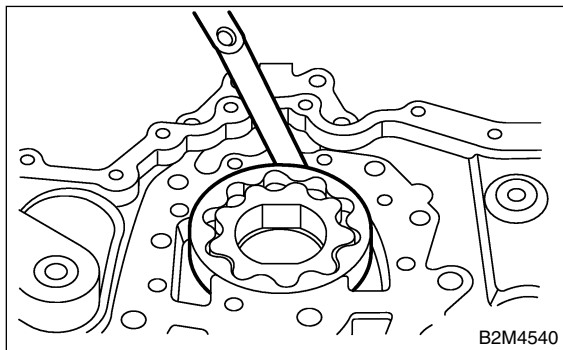

### 3. SIDE CLEARANCE S148070A1003

Measure clearance between oil pump inner rotor and rear chain cover. If the clearance exceeds the limit, replace rotor or pump body.

**Side clearance:**

**Standard**

**0.02 — 0.08 mm (0.0008 — 0.0031 in)**

**Limit**

**0.15 mm (0.0059 in)**

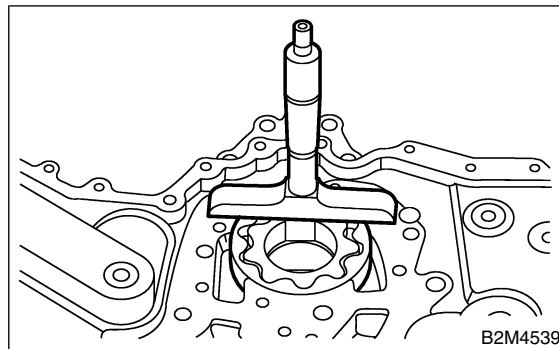

### 4. OIL PUMP CASE S148070A1004

Check the oil pump case for worn shaft hole, clogged oil passage, cracks and other faults.