

8. Engine Oil Filter S148585

A: REMOVAL S148585A18

- 1) Drain engine oil by loosening engine oil drain plug.

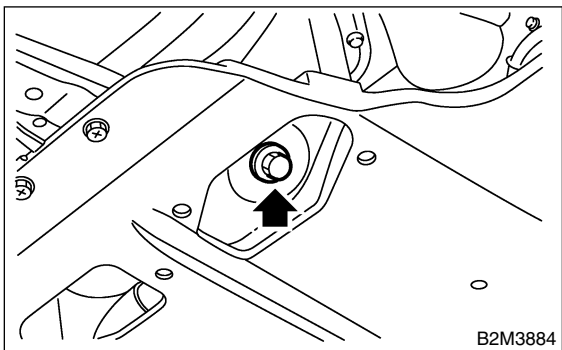

- 2) Remove access lid.

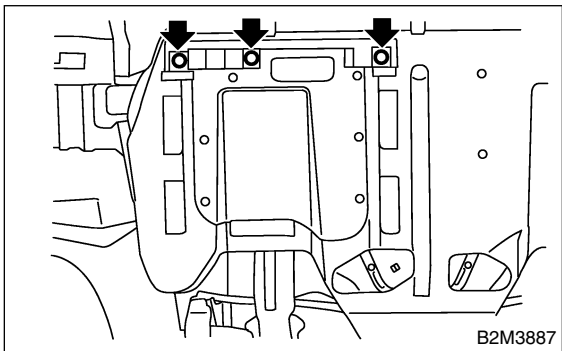

- 3) Remove oil filter with ST.
ST 498547000 OIL FILTER WRENCH

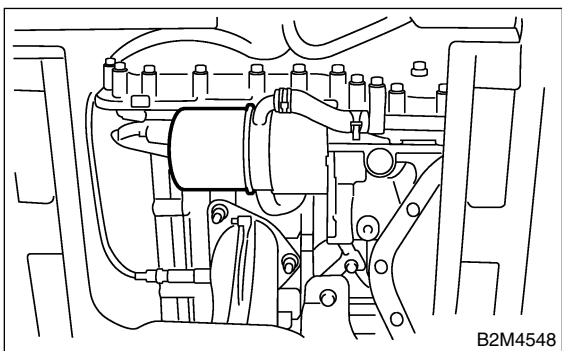

B: INSTALLATION S148585A11

- 1) Get a new oil filter and apply a thin coat of engine oil to the rubber seal.
- 2) Install oil filter by turning it by hand, being careful not to damage rubber seal.
- 3) Tighten more (approximately 3/4 turn) after the rubber seal contacts the oil cooler. Do not tighten excessively, or oil may leak.
- 4) Fill engine oil. <Ref. to LU(H6)-10, Engine Oil.>

C: INSPECTION S148585A10

- 1) After installing oil filter, run engine and make sure that no oil is leaking around rubber seal.

NOTE:

The filter element and filter case are permanently jointed; therefore, interior cleaning is not necessary.

- 2) Check the engine oil level. <Ref. to LU(H6)-10, INSPECTION, Engine Oil.>