

GENERAL DESCRIPTION

Mechanical

1. General Description S143001

A: SPECIFICATIONS S143001E49

Engine	Type		Horizontally opposed, liquid cooled, 6-cylinder, 4-stroke gasoline engine
	Valve arrangement		Chain driven, double over-head camshaft, 4-valve/cylinder
	Bore x Stroke		mm (in) 89.2 x 80 (3.51 x 3.150)
	Displacement		cm ³ (cu in) 3,000 (183.1)
	Compression ratio		10.7
	Compression pressure (350 rpm and fully open throttle)		kPa (kg/cm ² , psi) 1,275 — 1,471 (13.0 — 15.0, 185 — 213)
	Number of piston rings		Pressure ring: 2, Oil ring: 1
	Intake valve timing	Opening	5° BTDC
		Closing	55° ABDC
	Exhaust valve timing	Opening	52° BBDC
		Closing	0° ATDC
	Valve clearance	Intake	mm (in) 0.20 ^{+0.04} / _{-0.06} (0.0079 ^{+0.0016} / _{-0.0024})
		Exhaust	mm (in) 0.25±0.05 (0.0098±0.0020)
	Idle speed [At "P" or "N" position]		rpm 600±50 (No load) 700±50 (A/C switch ON)
Firing order		1 → 6 → 3 → 2 → 5 → 4	
Ignition timing		BTDC/rpm 10°±8°/600	

NOTE:

STD: Standard I.D.: Inner Diameter O.D.: Outer Diameter US: Undersize OS: Oversize

Camshaft	Bend limit		0.020 mm (0.0008 in)	
	Thrust clearance	Intake	STD	0.075 — 0.135 mm (0.0030 — 0.0053 in)
			Limit	0.155 mm (0.0061 in)
		Exhaust	STD	0.048 — 0.108 mm (0.0019 — 0.0043 in)
			Limit	0.130 mm (0.0051 in)
	Cam lobe height	Intake	STD	46.05 — 46.15 mm (1.8130 — 1.8169 in)
			Limit	45.95 mm (1.8091 in)
		Exhaust	STD	45.55 — 45.65 mm (1.7933 — 1.7972 in)
			Limit	45.45 mm (1.7894 in)
	Camshaft journal O.D.	Front	37.946 — 37.963 mm (1.4939 — 1.4946 in)	
		Center & Rear	27.946 — 27.963 mm (1.1002 — 1.1009 in)	
	Camshaft journal hole I.D.	Front	38.000 — 38.018 mm (1.4961 — 1.4968 in)	
		Center & Rear	28.000 — 28.018 mm (1.1024 — 1.1031 in)	
	Oil clearance	STD	0.037 — 0.072 mm (0.0015 — 0.0028 in)	
Limit		0.10 mm (0.0039 in)		
Cylinder head	Surface warpage limit		0.05 mm (0.0020 in)	
	Surface grinding limit		0.1 mm (0.004 in)	
	Standard height		124 mm (4.88 in)	
Valve seat	Refacing angle		90°	
	Contacting width	Intake	STD	1.0 mm (0.039 in)
			Limit	1.7 mm (0.067 in)
		Exhaust	STD	1.5 mm (0.059 in)
			Limit	2.2 mm (0.087 in)
Valve guide	Inner diameter		5.500 — 5.512 mm (0.2165 — 0.2170 in)	
	Protrusion above head		12.3 — 12.7 mm (0.484 — 0.500 in)	

GENERAL DESCRIPTION

Mechanical

Valve	Head edge thickness	Intake	STD	1.0 mm (0.039 in)
			Limit	0.8 mm (0.315 in)
		Exhaust	STD	1.2 mm (0.047 in)
			Limit	0.8 mm (0.315 in)
	Stem diameter		Intake	5.455 — 5.470 mm (0.2148 — 0.2154 in)
			Exhaust	5.455 — 5.460 mm (0.2148 — 0.2150 in)
	Stem oil clearance	STD	Intake	0.030 — 0.057 mm (0.0012 — 0.0022 in)
			Exhaust	0.040 — 0.067 mm (0.0016 — 0.0026 in)
	Overall length		Intake	103.5 mm (4.07 in)
			Exhaust	103.2 mm (4.06 in)
Valve spring	Free length		46.79 mm (1.8421 in)	
	Squareness		2.5°, 2.0 mm (0.079 in)	
	Tension/spring height	Set	186.2 — 205.8 N (18.99 — 20.99 kgf, 41.9 — 46.3 lb)/37.4 mm (1.472 in)	
Lift		446.5 — 493.5 N (45.54 — 50.34 kgf, 100.3 — 110.9 lb)/27.5 mm (1.083 in)		
Cylinder block	Surface warpage limit (mating with cylinder head)			0.05 mm (0.0020 in)
	Surface grinding limit			0.1 mm (0.004 in)
	Cylinder bore	STD	A	89.205 — 89.215 mm (3.5120 — 3.5124 in)
			B	89.195 — 89.205 mm (3.5116 — 3.5120 in)
	Taper		Limit	0.050 mm (0.0020 in)
	Out-of-roundness		Limit	0.050 mm (0.0020 in)
	Piston clearance		STD	0.010 — 0.030 mm (0.0004 — 0.0012 in)
Limit			0.050 mm (0.0020 in)	
Enlarging (boring) limit			0.5 mm (0.020 in)	
Piston	Outer diameter	STD	A	89.185 — 89.195 mm (3.5112 — 3.5116 in)
			B	89.175 — 89.185 mm (3.5108 — 3.5112 in)
		0.25 mm (0.0098 in) OS	89.425 — 89.435 mm (3.5207 — 3.5211 in)	
		0.50 mm (0.0197 in) OS	89.675 — 89.685 mm (3.5305 — 3.5309 in)	
Standard inner diameter of piston pin hole			22.000 — 22.006 mm (0.8661 — 0.8664 in)	
Piston pin	Outer diameter		21.994 — 22.000 mm (0.8659 — 0.8661 in)	
	Standard clearance between piston pin and hole in piston		0.004 — 0.008 mm (0.0002 — 0.0003 in)	
	Degree of fit		Piston pin must be fitted into position with thumb at 20°C (68°F).	
Piston ring	Piston ring gap	Top ring	STD	0.20 — 0.35 mm (0.0079 — 0.0138 in)
			Limit	1.0 mm (0.039 in)
		Second ring	STD	0.35 — 0.50 mm (0.0138 — 0.0197 in)
			Limit	1.0 mm (0.039 in)
	Oil ring	STD	0.20 — 0.60 mm (0.0079 — 0.0236 in)	
		Limit	1.5 mm (0.059 in)	
	Clearance between piston ring and piston ring groove	Top ring	STD	0.040 — 0.080 mm (0.0016 — 0.0031 in)
			Limit	0.15 mm (0.0059 in)
Second ring		STD	0.030 — 0.070 mm (0.0012 — 0.0028 in)	
		Limit	0.15 mm (0.0059 in)	
Connecting rod	Bend twist per 100 mm (3.94 in) in length		Limit	0.10 mm (0.0039 in)
	Side clearance	STD	0.070 — 0.330 mm (0.0028 — 0.0130 in)	
		Limit	0.4 mm (0.016 in)	

GENERAL DESCRIPTION

Mechanical

Connecting rod bearing	Oil clearance		STD	0.022 — 0.052 mm (0.0009 — 0.0020 in)
			Limit	0.065 mm (0.0026 in)
	Thickness at center portion		STD	1.490 — 1.502 mm (0.0587 — 0.0591 in)
			0.03 mm (0.0012 in) US	1.510 — 1.513 mm (0.0594 — 0.0596 in)
			0.05 mm (0.0020 in) US	1.520 — 1.523 mm (0.0598 — 0.0600 in)
		0.25 mm (0.0098 in) US	1.620 — 1.623 mm (0.0638 — 0.0639 in)	
Connecting rod bushing	Clearance between piston pin and bushing		STD	0 — 0.022 mm (0 — 0.0009 in)
			Limit	0.030 mm (0.0012 in)
Crankshaft	Bend limit			0.035 mm (0.0014 in)
	Crank pin and crank journal	Out-of-roundness		0.020 mm (0.0008 in) or less
		Grinding limit		0.250 mm (0.0098 in)
	Crank pin outer diameter		STD	51.984 — 52.000 mm (2.0466 — 2.0472 in)
			0.03 mm (0.0012 in) US	51.954 — 51.970 mm (2.0454 — 2.0461 in)
			0.05 mm (0.0020 in) US	51.934 — 51.950 mm (2.0446 — 2.0453 in)
			0.25 mm (0.0098 in) US	51.734 — 51.750 mm (2.0368 — 2.0374 in)
	Crank journal outer diameter	#1, #3, #5, #7	STD	63.992 — 64.008 mm (2.5194 — 2.5200 in)
			0.03 mm (0.0012 in) US	63.962 — 63.978 mm (2.5182 — 2.5188 in)
			0.05 mm (0.0020 in) US	63.942 — 63.958 mm (2.5174 — 2.5180 in)
			0.25 mm (0.0098 in) US	63.742 — 63.758 mm (2.5095 — 2.5102 in)
		#2, #4, #6	STD	63.992 — 64.008 mm (2.5194 — 2.5200 in)
			0.03 mm (0.0012 in) US	63.962 — 63.978 mm (2.5182 — 2.5188 in)
			0.05 mm (0.0020 in) US	63.942 — 63.958 mm (2.5174 — 2.5180 in)
			0.25 mm (0.0098 in) US	63.742 — 63.758 mm (2.5095 — 2.5102 in)
	Thrust clearance		STD	0.030 — 0.115 mm (0.0012 — 0.0045 in)
			Limit	0.25 mm (0.0098 in)
Oil clearance		STD	0.015 — 0.030 mm (0.0006 — 0.0012 in)	
		Limit	0.050 mm (0.0020 in)	
Crankshaft bearing	#1, #3, #5, #7	STD	1.992 — 2.005 mm (0.0784 — 0.0789 in)	
		0.03 mm (0.0012 in) US	2.017 — 2.020 mm (0.0794 — 0.0795 in)	
		0.05 mm (0.0020 in) US	2.027 — 2.030 mm (0.0798 — 0.0799 in)	
		0.25 mm (0.0098 in) US	2.127 — 2.130 mm (0.0837 — 0.0839 in)	
	#2, #4, #5	STD	1.996 — 2.000 mm (0.0786 — 0.0787 in)	
		0.03 mm (0.0012 in) US	2.019 — 2.020 mm (0.0795 — 0.0795 in)	
		0.05 mm (0.0020 in) US	2.029 — 2.032 mm (0.0799 — 0.0800 in)	
		0.25 mm (0.0098 in) US	2.129 — 2.132 mm (0.0838 — 0.0839 in)	

B: COMPONENT S143001A05

1. V-BELT S143001A0508

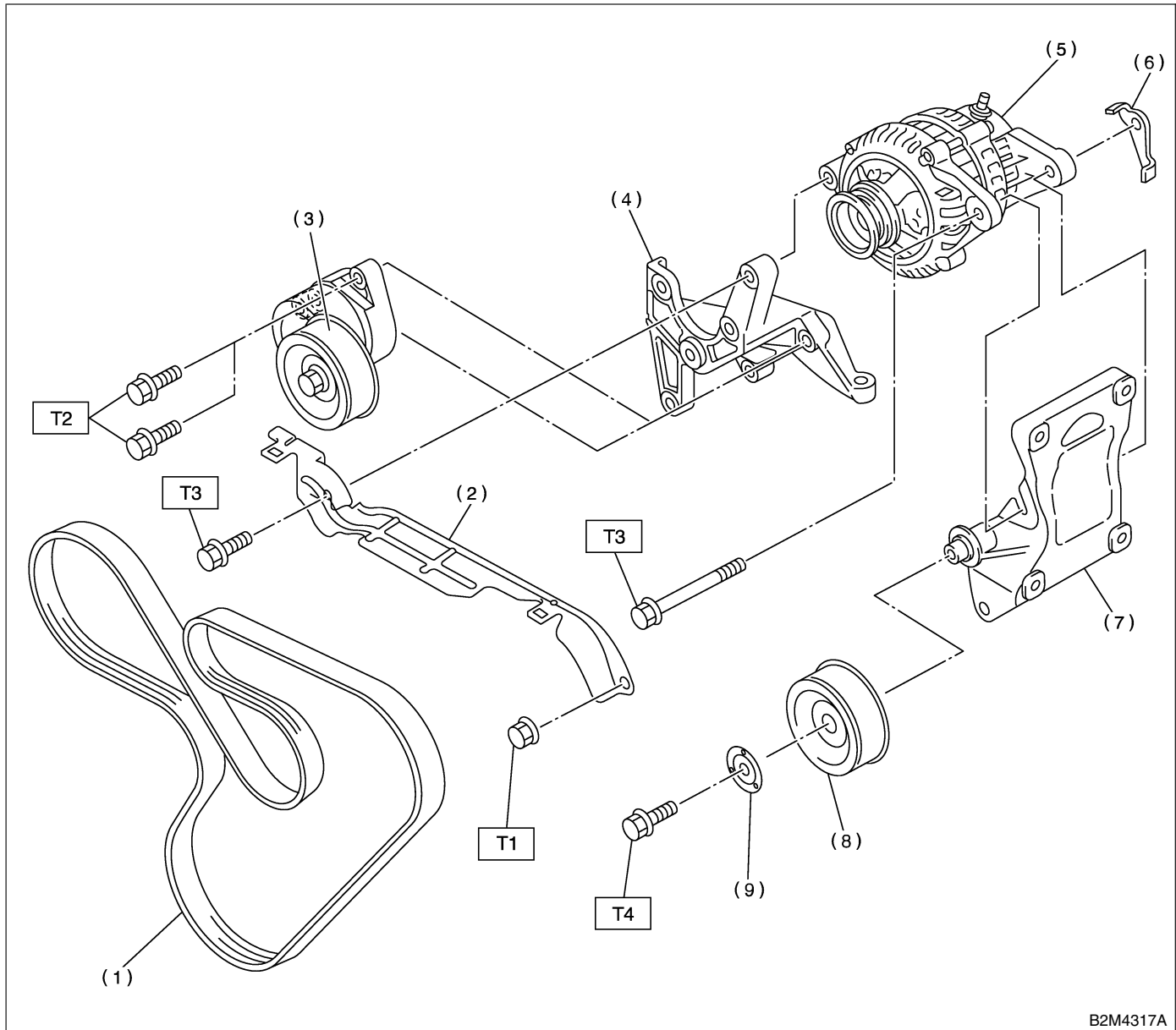

- | | |
|---------------------------------|-------------------------|
| (1) V-belt | (7) A/C compressor stay |
| (2) Belt cover | (8) Idler pulley |
| (3) Belt tensioner | (9) Idler pulley cover |
| (4) Power steering pump bracket | |
| (5) Generator | |
| (6) Generator plate | |

Tightening torque: N·m (kgf·m, ft·lb)

T1: 6.4 (0.65, 4.7)

T2: 20 (2.0, 14)

T3: 25 (2.5, 18)

T4: 33 (3.4, 25)

GENERAL DESCRIPTION

Mechanical

2. TIMING CHAIN COVER S143001A0509

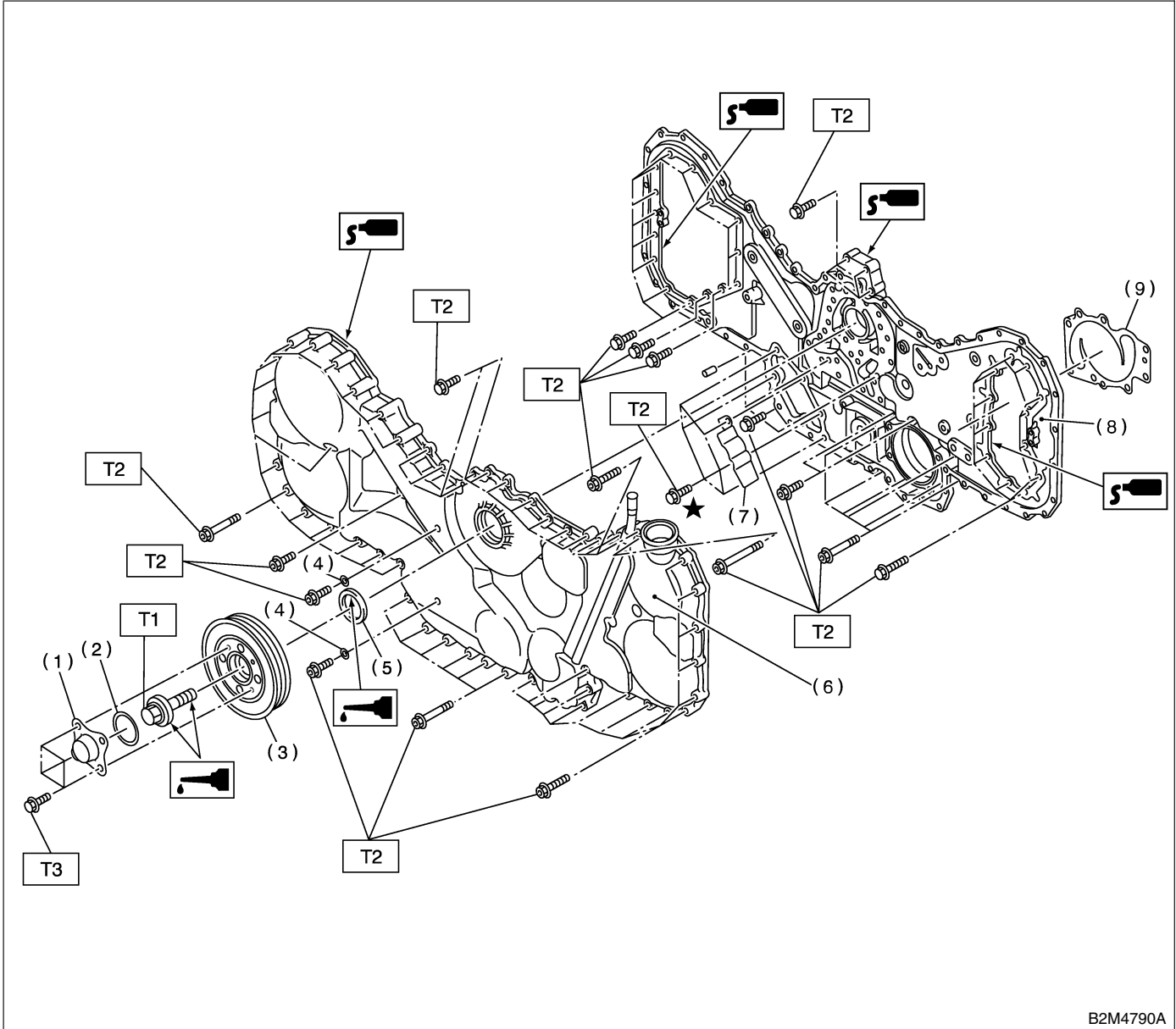

- | | |
|------------------------|-----------------------|
| (1) Crank pulley cover | (7) Baffle |
| (2) O-ring | (8) Rear chain cover |
| (3) Crank pulley | (9) Water pump gasket |
| (4) Sealing washer | |
| (5) Oil seal | |
| (6) Front chain cover | |

Tightening torque: N·m (kgf·m, ft·lb)

T1: Refer to ME(H6)-39, Crankshaft Pulley.

T2: Refer to ME(H6)-40, Front Chain Cover and ME(H6)-49, Rear Chain Cover.

T3: 6.4 (0.65, 4.7)

ME(H6)-6

3. TIMING BELT S143001A0501

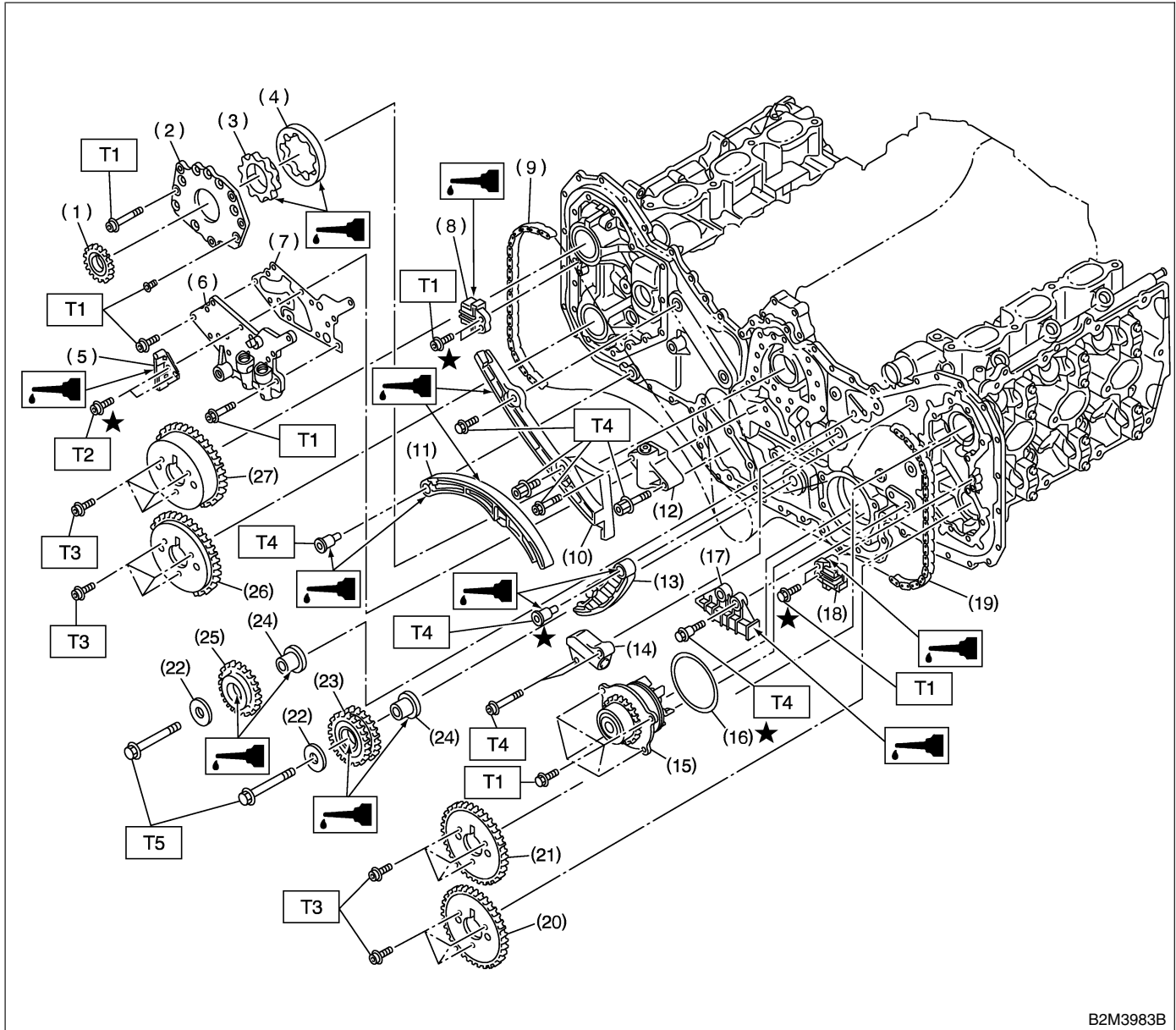

B2M3983B

- | | | |
|--|--|--------------------------------|
| (1) Crank sprocket | (13) Chain tensioner lever (LH) | (25) Idler sprocket (Upper) |
| (2) Oil pump cover | (14) Chain tensioner (LH) | (26) Exhaust cam sprocket (RH) |
| (3) Inner rotor | (15) Water pump | (27) Intake cam sprocket (RH) |
| (4) Outer rotor | (16) O-ring | |
| (5) Chain guide (Center) | (17) Chain guide (LH) | |
| (6) Relief valve case | (18) Chain guide (Left-hand between
cams) | |
| (7) Relief valve case gasket | (19) Timing chain (LH) | |
| (8) Chain guide (Right-hand
between cams) | (20) Exhaust cam sprocket (LH) | |
| (9) Timing chain (RH) | (21) Intake cam sprocket (LH) | |
| (10) Chain guide (RH) | (22) Idler sprocket plate | |
| (11) Chain tensioner lever (RH) | (23) Idler sprocket (Lower) | |
| (12) Chain tensioner (RH) | (24) Idler sprocket color | |

Tightening torque: N·m (kgf·m, ft·lb)

T1: 6.4 (0.64, 4.7)

T2: 7.8 (0.80, 5.8)

T3: 13 (1.3, 9.4)

T4: 16 (1.6, 11.6)

T5: 69 (7.0, 50.6)

GENERAL DESCRIPTION

Mechanical

4. CYLINDER HEAD AND CAMSHAFT

S143001A0502

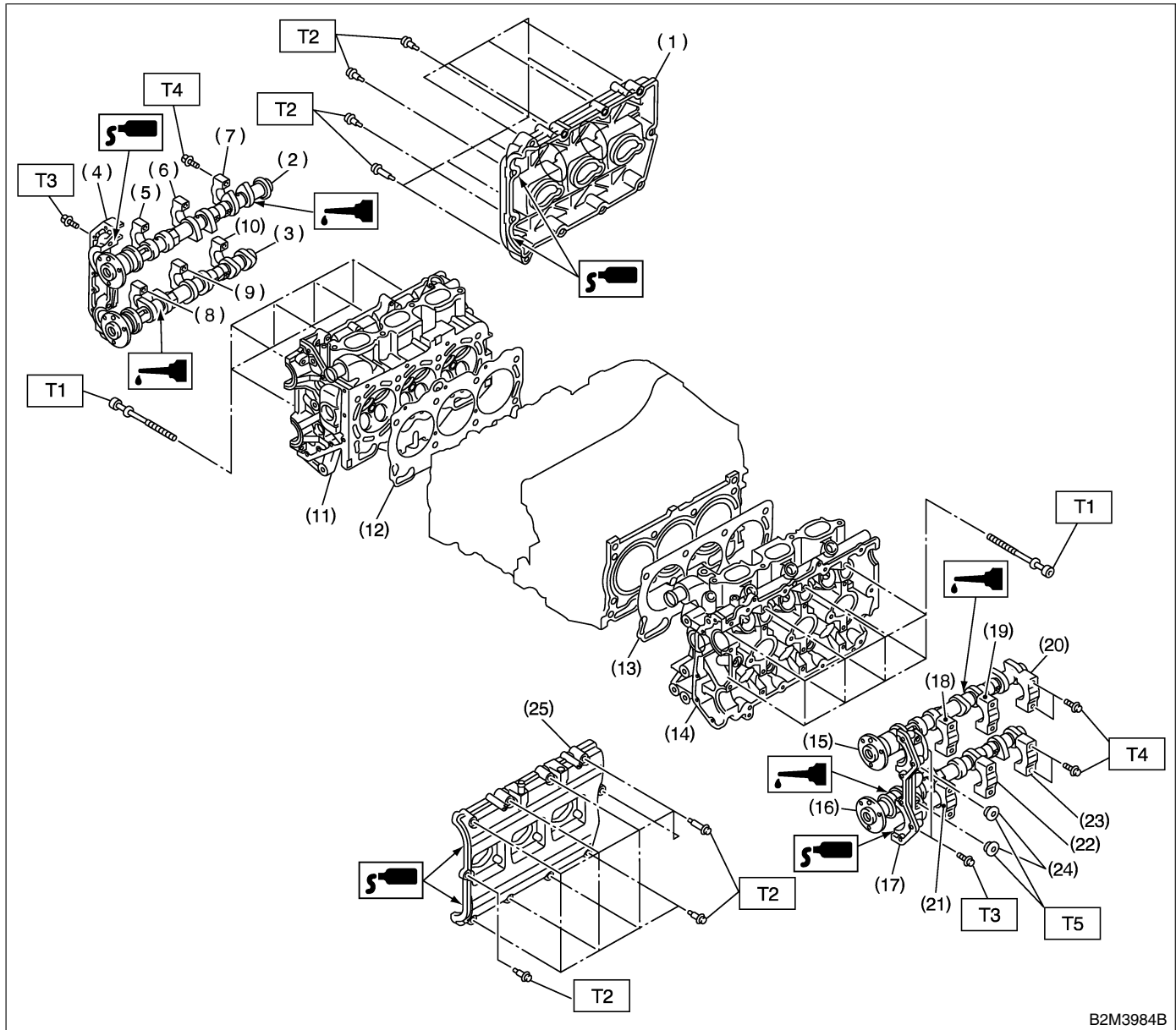

B2M3984B

- | | |
|--------------------------------------|---------------------------------------|
| (1) Rocker cover (RH) | (12) Cylinder head gasket (RH) |
| (2) Intake camshaft (RH) | (13) Cylinder head gasket (LH) |
| (3) Exhaust camshaft (RH) | (14) Cylinder head (LH) |
| (4) Front camshaft cap (RH) | (15) Intake camshaft (LH) |
| (5) Intake camshaft cap (Front RH) | (16) Exhaust camshaft (LH) |
| (6) Intake camshaft cap (Center RH) | (17) Front camshaft cap (LH) |
| (7) Intake camshaft cap (Rear RH) | (18) Intake camshaft cap (Front LH) |
| (8) Exhaust camshaft cap (Front RH) | (19) Intake camshaft cap (Center LH) |
| (9) Exhaust camshaft cap (Center RH) | (20) Intake camshaft cap (Rear LH) |
| (10) Exhaust camshaft cap (Rear RH) | (21) Exhaust camshaft cap (Front LH) |
| (11) Cylinder head (RH) | (22) Exhaust camshaft cap (Center LH) |
| | (23) Exhaust camshaft cap (Rear LH) |

- | |
|------------------------|
| (24) Plug |
| (25) Rocker cover (LH) |

Tightening torque: N·m (kgf·m, ft·lb)

T1: Ref. to ME(H6)-55, Cylinder Head Assembly.

T2: Ref. to ME(H6)-51, Camshaft.

T3: 9.8 (1.0, 7.2)

T4: 16 (1.6, 12)

T5: 59 (6.0, 43)

ME(H6)-8

5. CYLINDER HEAD AND VALVE ASSEMBLY

S143001A0504

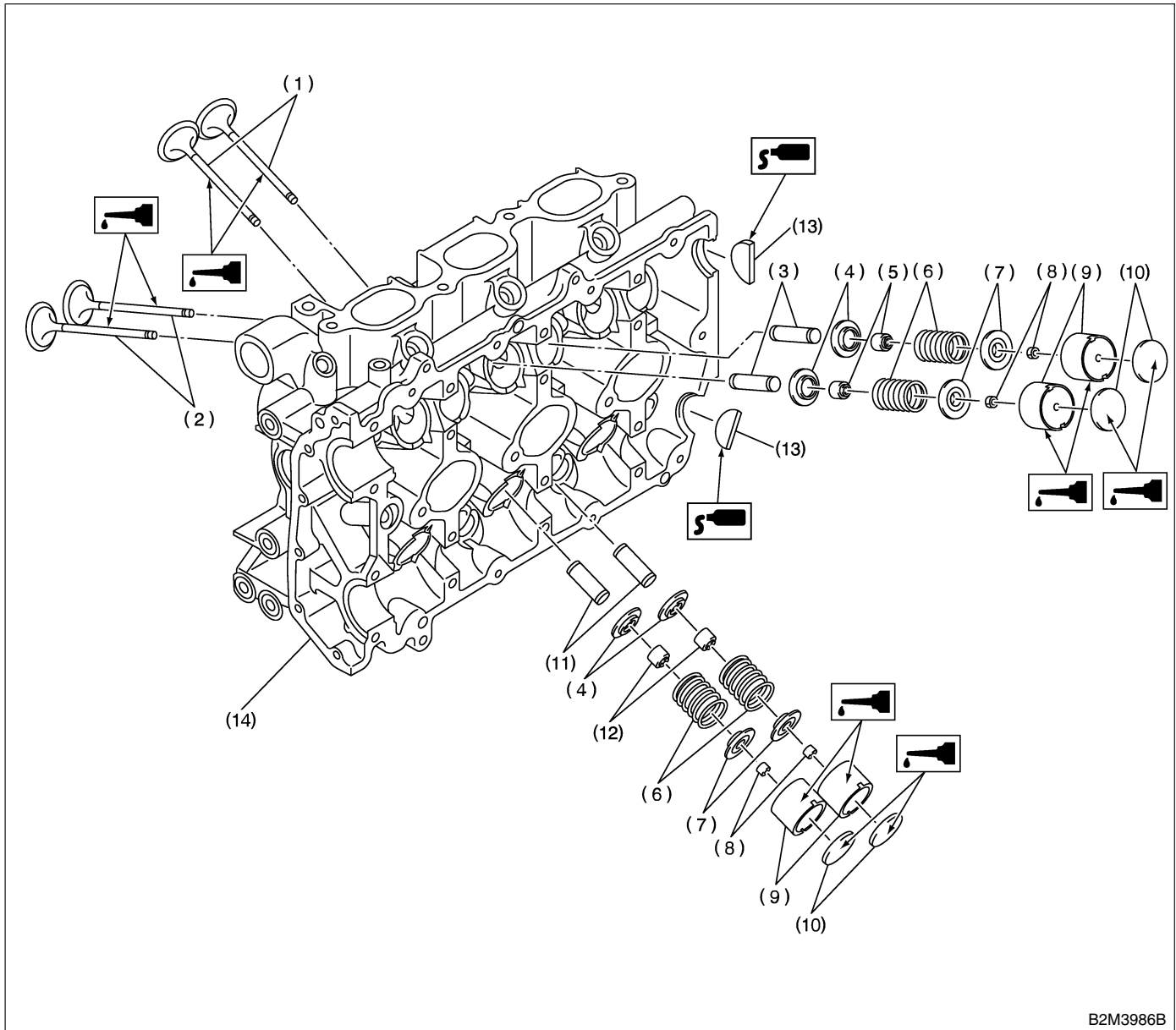

B2M3986B

- | | | |
|---------------------------|------------------|-----------------------------|
| (1) Exhaust valve | (6) Valve spring | (11) Exhaust valve guide |
| (2) Intake valve | (7) Retainer | (12) Exhaust valve oil seal |
| (3) Intake valve guide | (8) Retainer key | (13) Cylinder head plug |
| (4) Valve spring seat | (9) Valve lifter | (14) Cylinder head |
| (5) Intake valve oil seal | (10) Shim | |

GENERAL DESCRIPTION

Mechanical

6. CYLINDER BLOCK S143001A0505

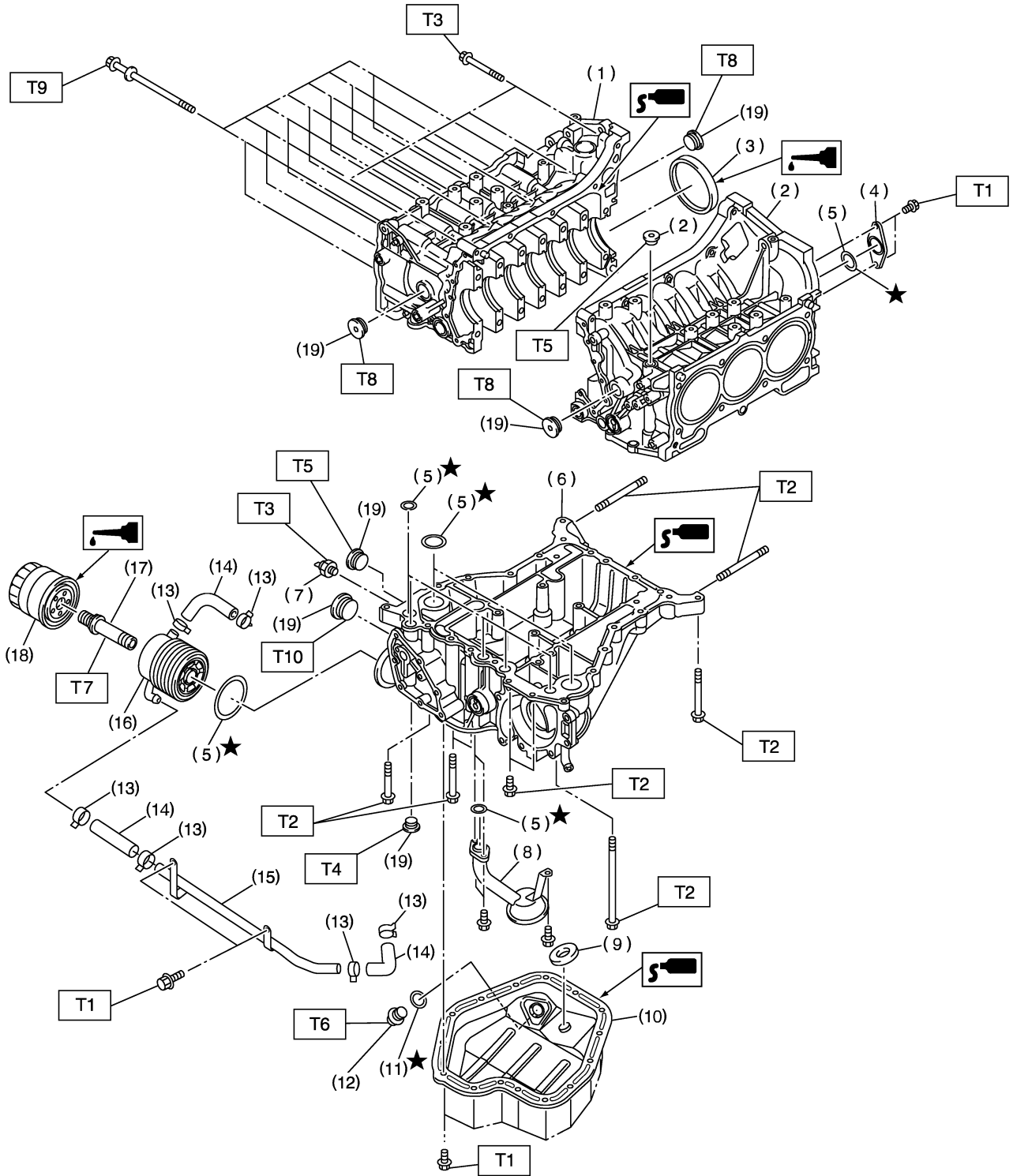

B2M3987B

GENERAL DESCRIPTION

Mechanical

- (1) Cylinder block (RH)
- (2) Cylinder block (LH)
- (3) Rear oil seal
- (4) Service hole cover
- (5) O-ring
- (6) Oil pan upper
- (7) Oil pressure switch
- (8) Oil strainer
- (9) Magnet
- (10) Oil pan
- (11) Metal gasket

- (12) Drain plug
- (13) Clamp
- (14) Hose
- (15) Oil cooler pipe
- (16) Oil cooler
- (17) Connector
- (18) Oil filter
- (19) Plug

Tightening torque: N·m (kgf·m, ft·lb)

T1: 6.4 (0.65, 4.7)

T2: 18 (1.8, 13.0)

T3: 25 (2.5, 18)

T4: 34 (3.5, 25)

T5: 37 (3.8, 27)

T6: 44 (4.5, 33)

T7: 54 (5.5, 40)

T8: 69 (7.0, 51)

T9: Ref. to ME(H6)-61, Cylinder Block.

T10: 90 (9.2, 67)

GENERAL DESCRIPTION

Mechanical

7. CRANKSHAFT AND PISTON S143001A0506

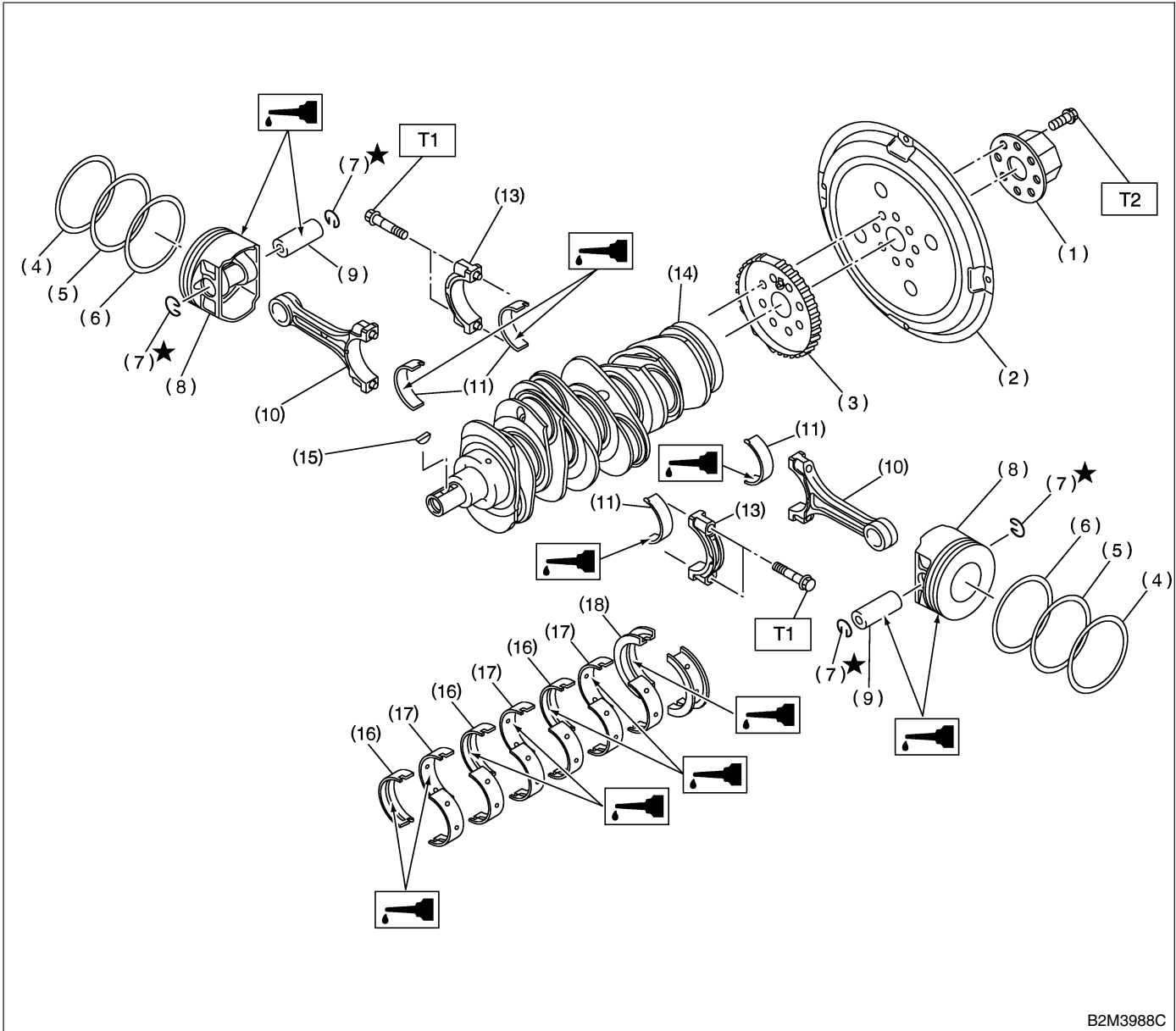

- (1) Reinforcement
- (2) Drive plate
- (3) Crankshaft position sensor plate
- (4) Top ring
- (5) Second ring
- (6) Oil ring
- (7) Circlip
- (8) Piston

- (9) Piston pin
- (10) Connecting rod
- (11) Connecting rod bearing
- (12) Connecting rod bolt
- (13) Connecting rod cap
- (14) Crankshaft
- (15) Woodruff key
- (16) Crankshaft bearing #1, #3, #5
- (17) Crankshaft bearing #2, #4, #6
- (18) Crankshaft bearing #7

- (17) Crankshaft bearing #2, #4, #6
- (18) Crankshaft bearing #7

Tightening torque: N·m (kgf·m, ft·lb)

T1: 53 (5.4, 39)

T2: 81 (8.3, 60)

8. ENGINE MOUNTING S143001A0507

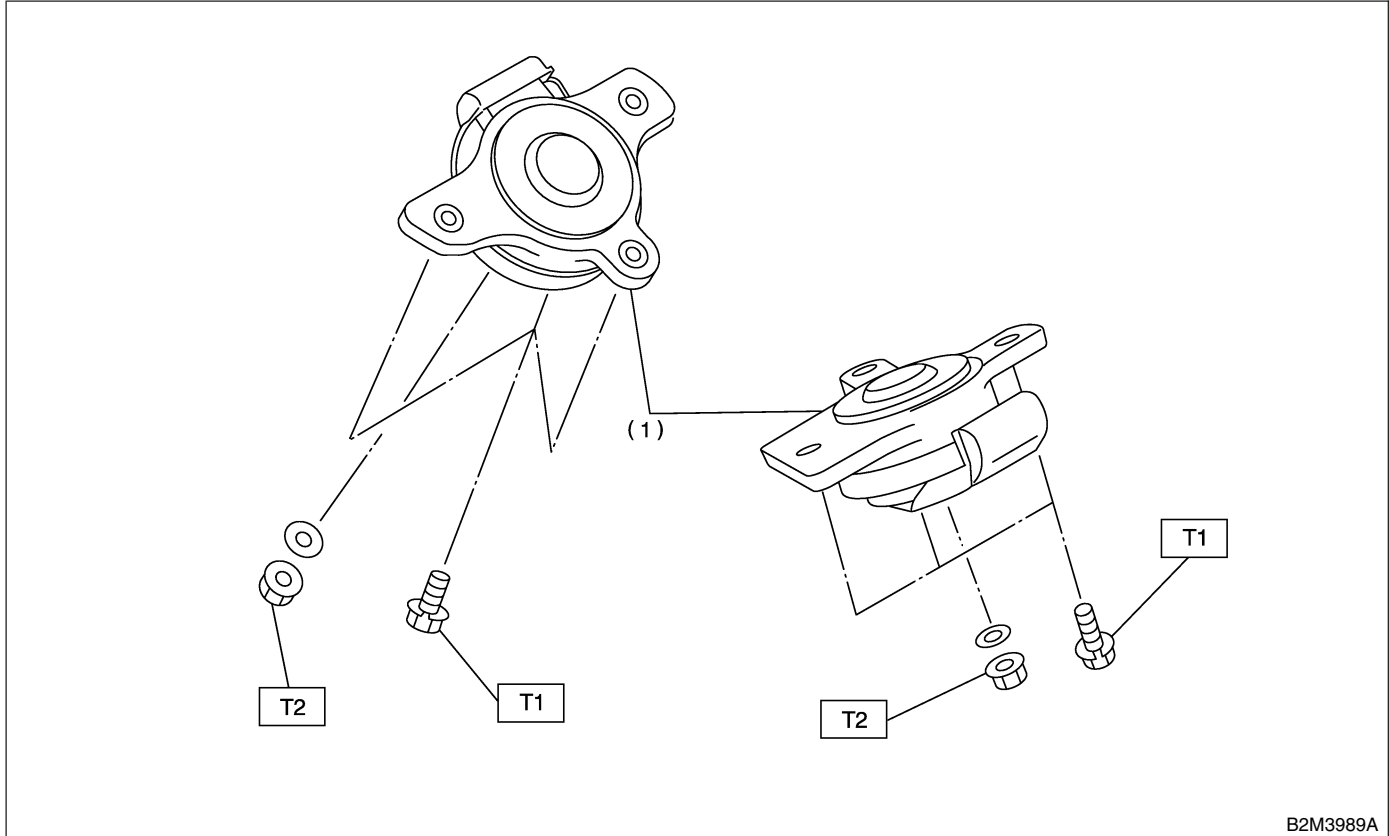

(1) Front cushion rubber

Tightening torque: N·m (kgf·m, ft·lb)

T1: 34 (3.5, 25.3)

T2: 74 (7.5, 54)

C: CAUTION S143001A03

- Wear working clothing, including a cap, protective goggles, and protective shoes during operation.
- Remove contamination including dirt and corrosion before removal, installation or disassembly.
- Keep the disassembled parts in order and protect them from dust or dirt.
- Before removal, installation or disassembly, be sure to clarify the failure. Avoid unnecessary removal, installation, disassembly, and replacement.
- Be careful not to burn your hands, because each part in the vehicle is hot after running.
- Be sure to tighten fasteners including bolts and nuts to the specified torque.
- Place shop jacks or safety stands at the specified points.
- Before disconnecting electrical connectors of sensors or units, be sure to disconnect ground cable from battery.

- All parts should be thoroughly cleaned, paying special attention to the engine oil passages, pistons and bearings.
- Rotating parts and sliding parts such as piston, bearing and gear should be coated with oil prior to assembly.
- Be careful not to let oil, grease or coolant contact the clutch disc and flywheel.
- All removed parts, if to be reused, should be reinstalled in the original positions and directions.
- Bolts, nuts and washers should be replaced with new ones as required.
- Even if necessary inspections have been made in advance, proceed with assembly work while making rechecks.
- Remove or install engine in an area where chain hoists, lifting devices, etc. are available for ready use.
- Be sure not to damage coated surfaces of body panels with tools or stain seats and windows with coolant or oil. Place a cover over fenders, as required, for protection.
- Prior to starting work, prepare the following:

GENERAL DESCRIPTION

Mechanical

Service tools, clean cloth, containers to catch coolant and oil, wire ropes, chain hoist, transmission jacks, etc.

- Lift-up or lower the vehicle when necessary. Make sure to support the correct positions.

D: PREPARATION TOOL S143001A17

1. SPECIAL TOOLS S143001A1701

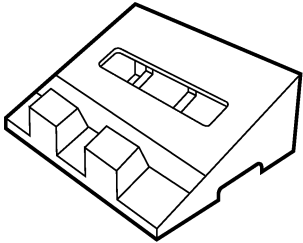
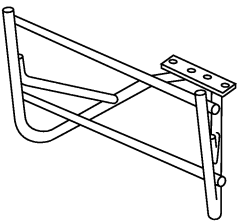
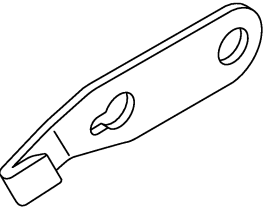
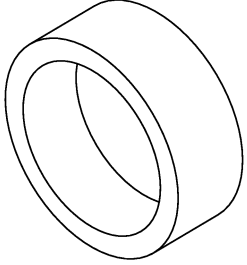
ILLUSTRATION	TOOL NUMBER	DESCRIPTION	REMARKS
 <p style="text-align: center;">B2M3990</p>	18250AA000	CYLINDER HEAD TABLE	<ul style="list-style-type: none"> ● Used for replacing valve guides. ● Used for removing and installing valve springs.
 <p style="text-align: center;">B2M3991</p>	18232AA000	ENGINE STAND	Used for engine disassembly and assembly.
 <p style="text-align: center;">B2M3853</p>	498497100	CRANKSHAFT STOPPER	Used for stopping rotation of flywheel when loosening and tightening crankshaft pulley bolt, etc.
 <p style="text-align: center;">B2M3854</p>	18254AA000	PISTON GUIDE	Used for installing piston in cylinder.

GENERAL DESCRIPTION

Mechanical

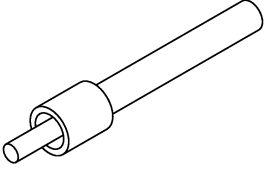
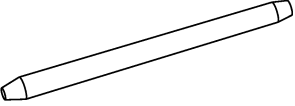
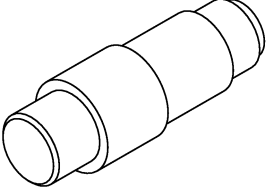
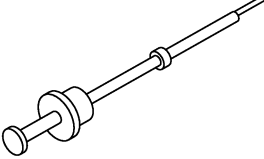
ILLUSTRATION	TOOL NUMBER	DESCRIPTION	REMARKS
 <p style="text-align: center;">B2M3855</p>	498857100	VALVE OIL SEAL GUIDE	Used for press-fitting of intake and exhaust valve guide oil seals.
 <p style="text-align: center;">B2M3993</p>	18253AA000	PISTON PIN GUIDE	Used for installing piston pin, piston and connecting rod.
 <p style="text-align: center;">B2M3857</p>	18350AA000	CONNECTING ROD BUSHING REMOVER & INSTALLER	Used for removing and installing connecting rod bushing.
 <p style="text-align: center;">B2M3858</p>	499097500	PISTON PIN REMOVER ASSY	Used for removing piston pin.

GENERAL DESCRIPTION

Mechanical

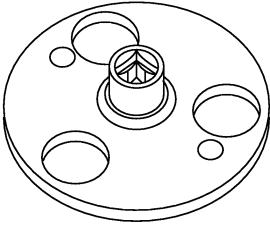
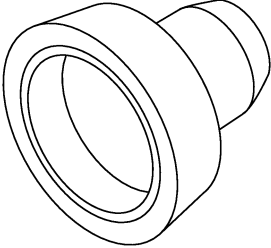
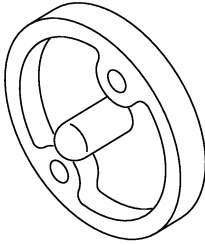
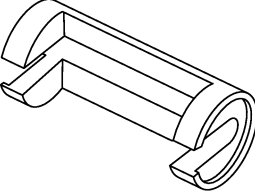
ILLUSTRATION	TOOL NUMBER	DESCRIPTION	REMARKS
 <p style="text-align: right;">B2M3995</p>	18231AA000	CAMSHAFT SPROCKET WRENCH	Used for removing and installing camshaft sprocket.
 <p style="text-align: right;">B2M3861</p>	499587200	CRANKSHAFT OIL SEAL INSTALLER	<ul style="list-style-type: none"> ● Used for installing crankshaft oil seal. ● Used with CRANKSHAFT OIL SEAL GUIDE (499597100).
 <p style="text-align: right;">B2M3863</p>	499597100	CRANKSHAFT OIL SEAL GUIDE	<ul style="list-style-type: none"> ● Used for installing crankshaft oil seal. ● Used with CRANKSHAFT OIL SEAL INSTALLER (499587200).
 <p style="text-align: right;">B2M3864</p>	499718000	VALVE SPRING REMOVER	Used for removing and installing valve spring.

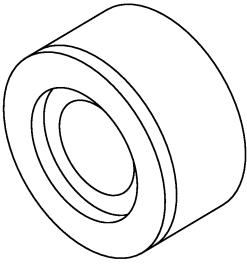
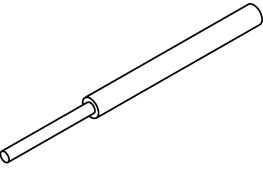
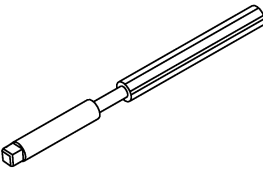
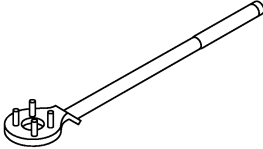

GENERAL DESCRIPTION

Mechanical

ILLUSTRATION	TOOL NUMBER	DESCRIPTION	REMARKS
 <p style="text-align: right;">B2M3865</p>	18251AA000	VALVE GUIDE ADJUSTER	Used for installing valve guides.
 <p style="text-align: right;">B2M3867</p>	499765700	VALVE GUIDE REMOVER	Used for removing valve guides.
 <p style="text-align: right;">B2M3868</p>	499765900	VALVE GUIDE REAMER	Used for reaming valve guides.
 <p style="text-align: right;">B2M3870</p>	499977100	CRANK PULLEY WRENCH	Used for stopping rotation of crankshaft pulley when loosening and tightening crankshaft pulley bolts.

GENERAL DESCRIPTION

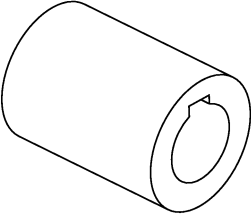
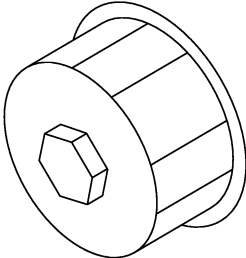
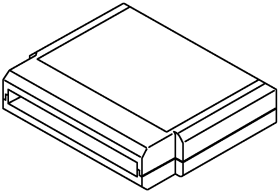
Mechanical

ILLUSTRATION	TOOL NUMBER	DESCRIPTION	REMARKS
 <p style="text-align: center;">B2M3871</p>	18252AA000	CRANKSHAFT SOCKET	Used for rotating crankshaft.
 <p style="text-align: center;">B2M3872</p>	498547000	OIL FILTER WRENCH	Used for removing and installing oil filter.
 <p style="text-align: center;">B2M3876</p>	24082AA190 (Newly adopted tool)	CARTRIDGE	Troubleshooting for electrical systems.
 <p style="text-align: center;">B2M3877</p>	22771AA020	SELECT MONITOR KIT	Troubleshooting for electrical systems. ● English: 22771AA020 (With printer) 22771AA030 (Without printer)

GENERAL DESCRIPTION

Mechanical

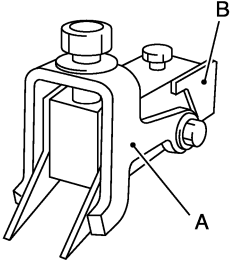
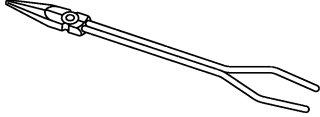
ILLUSTRATION	TOOL NUMBER	DESCRIPTION	REMARKS
 <p>B2M3992A</p>	18329AA000	SHIM REPLACER ASSY	Used for correct valve clearance.
	A: 18330AA010	LIFTER	If 498187200 SHIM REPLACER ASSY (H4) tool is available, it is commonly used for H6 by partially replacing the following parts: ● LIFTER (H4) → LIFTER (H6) A: 18330AA010 ● SLIDER (H4) → SLIDER (H6) B: 18351AA000
	B: 18351AA000	SLIDER	
 <p>B2M3994</p>	18233AA000	PISTON PIN CIR-CLIP PLIERS	Used for removing piston pin circlip.

2. GENERAL PURPOSE TOOLS S143001A1702

TOOL NAME	REMARKS
Compression gauge	Used for measuring compression.

E: PROCEDURE S143001E45

It is possible to conduct the following service procedures with engine on the vehicle, however, the procedures described in this section are based on the condition that the engine is removed from the vehicle.

- Camshaft
- Cylinder Head