

15. Rear Chain Cover S143741

A: REMOVAL S143741A18

- 1) Remove crankshaft pulley. <Ref. to ME(H6)-39, REMOVAL, Crankshaft Pulley.>
- 2) Remove front chain cover. <Ref. to ME(H6)-40, REMOVAL, Front Chain Cover.>
- 3) Remove timing chain. <Ref. to ME(H6)-42, REMOVAL, Timing Chain Assembly.>
- 4) Remove camshaft sprocket. <Ref. to ME(H6)-47, REMOVAL, Camshaft Sprocket.>
- 5) Remove crankshaft sprocket.
- 6) Remove oil pump. (B)
<Ref. to LU(H6)-12, REMOVAL, Oil Pump.>
- 7) Remove oil pump relief valve case.
<Ref. to LU(H6)-14, REMOVAL, Oil Pump Relief Valve.>
- 8) Remove water pump.
<Ref. to CO(H6)-20, REMOVAL, Water Pump.>
- 9) Remove rear chain cover.

NOTE:

There are seven different types of mounting bolts. Sort them into separate containers to avoid confusion at installation.

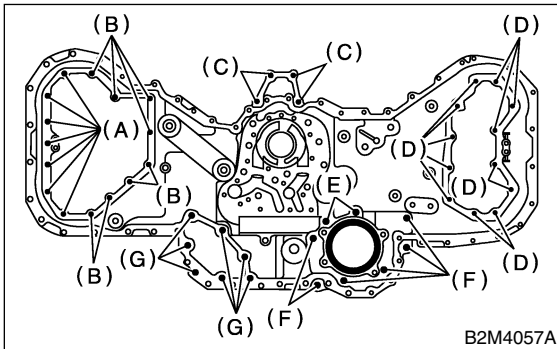

Bolt dimension:

- (A) 6 × 14
- (B) 6 × 18 (Silver)
- (C) 6 × 30
- (D) 6 × 18
- (E) 6 × 40
- (F) 6 × 30
- (G) 6 × 22

B: INSTALLATION S143741A11

- 1) Remove old fluid packing on the matching surface, and degrease it.

- 2) Apply fluid packing to the mating surface of rear chain cover.

Fluid packing:

THREE BOND 1280B

Fluid packing application diameter:

- (A) 1.0±0.5 mm (0.039±0.020 in)
- (B) 3.0±1.0 mm (0.118±0.039 in)

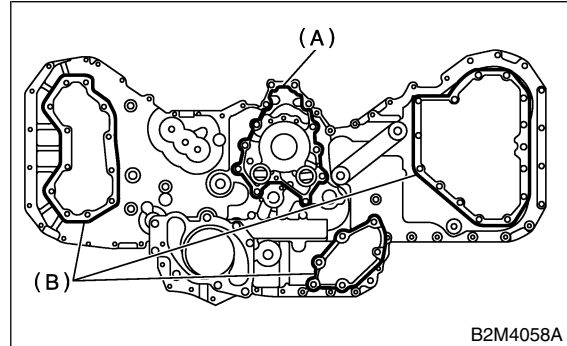

- 3) Install O-ring.

NOTE:

Do not reuse the O-ring.

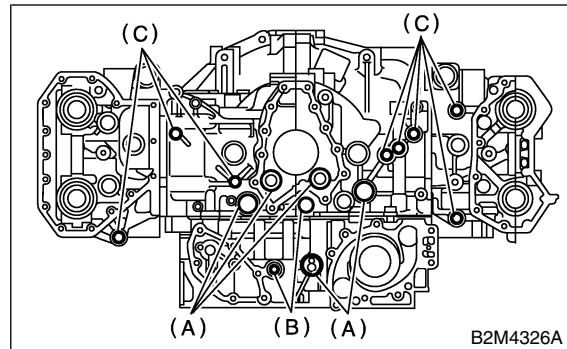

- (A) O-ring (Large)
- (B) O-ring (Medium)
- (C) O-ring (Small)

REAR CHAIN COVER

Mechanical

4) Temporarily tighten rear chain cover.

CAUTION:

Do not confuse the mounting positions of the bolts.

NOTE:

Replace mounting bolts (G) with new ones.

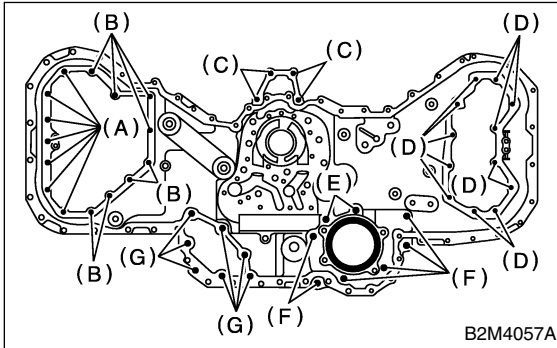

Bolt dimension:

- (A) 6 × 14
- (B) 6 × 18 (Silver)
- (C) 6 × 30
- (D) 6 × 18
- (E) 8 × 40
- (F) 8 × 30
- (G) 6 × 22

5) Tighten the bolts in the numerical sequence shown in figure.

Tightening torque:

(1) to (11)	9 N·m (0.9 kgf-m, 6.5 ft-lb)
(12) to (19)	20 N·m (2.0 kgf-m, 14 ft-lb)
(20) to (31)	9 N·m (0.9 kgf-m, 6.5 ft-lb)
(32) to (39)	12 N·m (1.2 kgf-m, 8.7 ft-lb)
(40) to (46)	9 N·m (0.9 kgf-m, 6.5 ft-lb)

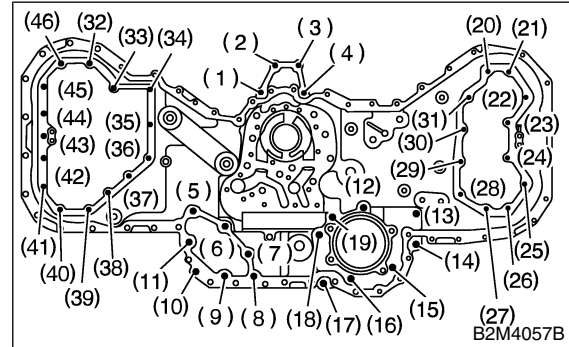

6) Install water pump.

<Ref. to CO(H6)-20, INSTALLATION, Water Pump.>

7) Install oil pump relief valve.

<Ref. to LU(H6)-14, INSTALLATION, Oil Pump Relief Valve.>

8) Install oil pump.

<Ref. to LU(H6)-12, INSTALLATION, Oil Pump.>

9) Install crankshaft sprocket.

10) Install camshaft sprocket. <Ref. to ME(H6)-47, INSTALLATION, Camshaft Sprocket.>

11) Install timing chain. <Ref. to ME(H6)-43, INSTALLATION, Timing Chain Assembly.>

12) Install front chain cover. <Ref. to ME(H6)-40, INSTALLATION, Front Chain Cover.>

13) Install crankshaft pulley. <Ref. to ME(H6)-39, INSTALLATION, Crankshaft Pulley.>