

STARTER

Starting/Charging Systems

2. Starter S149012

A: REMOVAL S149012A18

- 1) Disconnect battery ground cable.

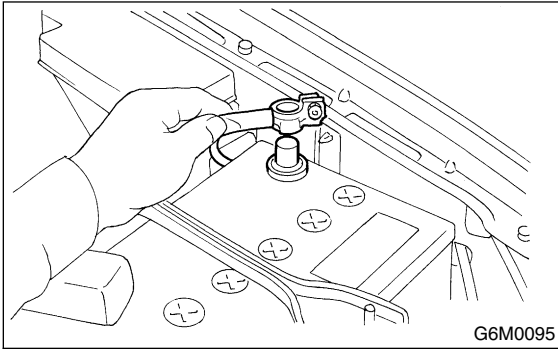

- 2) Remove air intake chamber. <Ref. to IN(H6)-6, REMOVAL, Air Intake Chamber.>
- 3) Disconnect connector and terminal from starter.

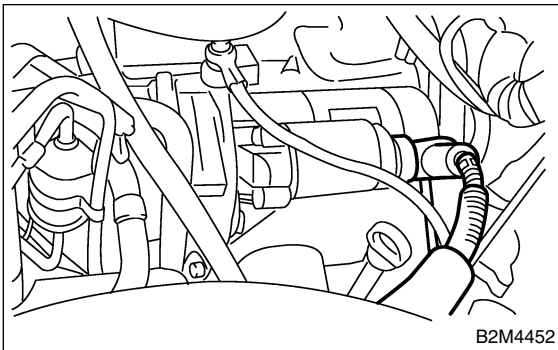

- 4) Remove starter from transmission.

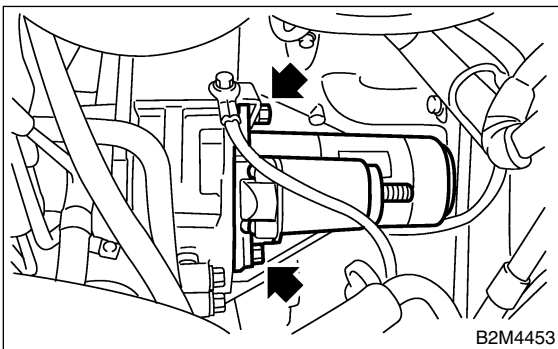

B: INSTALLATION S149012A11

Install in the reverse order of removal.

Tightening torque:
50 N·m (5.1 kgf-m, 37 ft-lb)

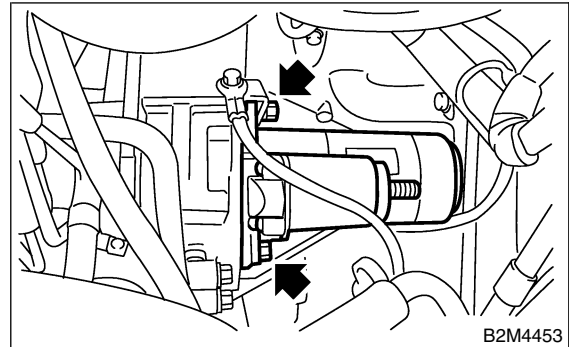

C: DISASSEMBLY S149012A06

- 1) Loosen nut which holds terminal M of switch assembly, and disconnect connector.

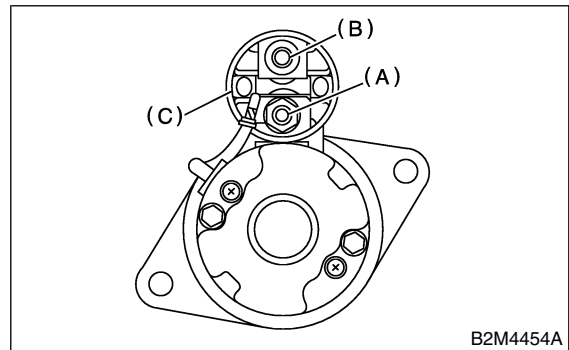

- (A) Terminal M
- (B) Terminal B
- (C) Terminal S

STARTER

2) Remove bolts which hold switch assembly, and remove switch assembly, plunger and plunger spring from starter as a unit.

CAUTION:

Be careful because pinion gap adjustment washer may sometimes be used on the mounting surface of switch assembly.

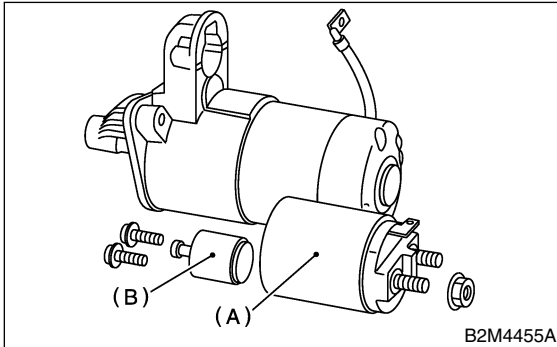

- (A) Switch ASSY
- (B) Plunger

3) Remove both through-bolts and brush holder screws, and detach rear bracket and brush holder.

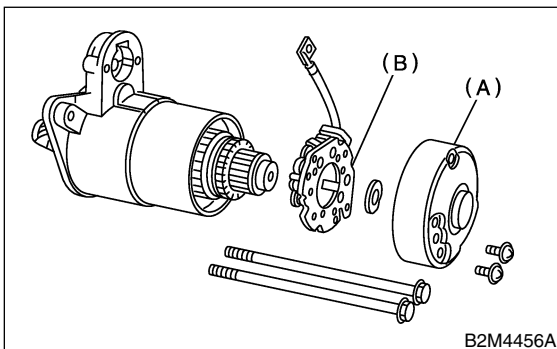

- (A) Rear bracket
- (B) Brush holder

4) Remove armature and yoke. Ball used as a bearing will then be removed from the end of armature.

CAUTION:

Be sure to mark an alignment mark on yoke and front bracket before removing yoke.

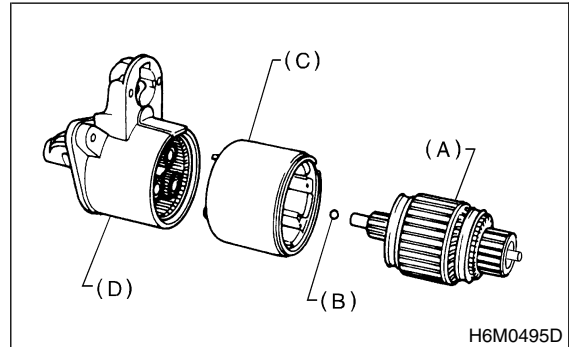

- (A) Armature
- (B) Ball
- (C) Yoke
- (D) Front bracket

5) Remove packing A, three planetary gears, packing B and plate.

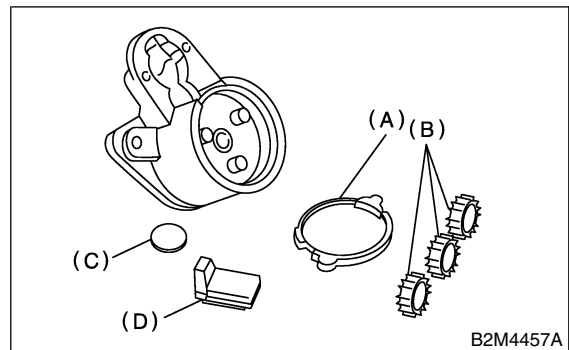

- (A) Packing A
- (B) Planetary gear
- (C) Plate
- (D) Packing B

STARTER

Starting/Charging Systems

6) Remove shaft assembly and overrunning clutch as a unit.

CAUTION:

Record the direction of lever before removing.

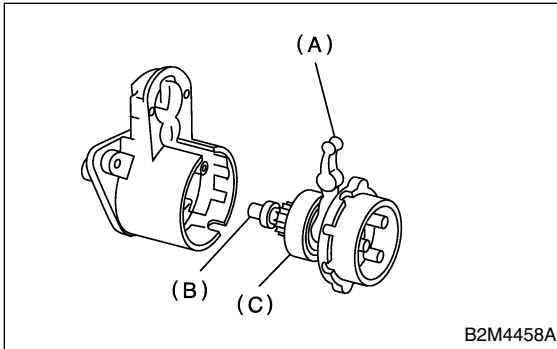

- (A) Lever
- (B) Shaft ASSY
- (C) Overrunning clutch

7) Remove overrunning clutch from shaft assembly as follows:

- (1) Remove stopper from ring by lightly tapping a fit tool placed on stopper.
- (2) Remove ring, stopper and clutch from shaft.

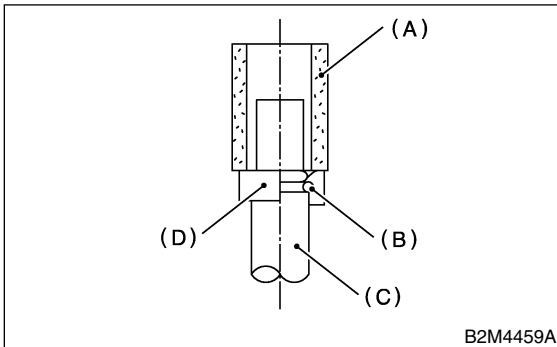

- (A) Tool
- (B) Ring
- (C) Shaft
- (D) Stopper

D: ASSEMBLY S149012A02

Assemble in the reverse order of disassembly. Do the following:

- 1) Carefully assemble all parts in the order of assembly and occasionally inspect nothing has been overlooked.
- 2) Apply grease to the following parts during assembly.

Grease:

ESSO BEACON 325
SHELL ALVANIA GREASE RA
or equivalent

- Front and rear bracket sleeve bearing
 - Armature shaft gear
 - Outer periphery of plunger
 - Mating surface of plunger and lever
 - Gear shaft splines
 - Mating surface of lever and clutch
 - Ball at the armature shaft end
 - Internal and planetary gears
- 3) After assembling parts correctly, make sure starter operates properly.

E: INSPECTION S149012A10

1. ARMATURE S149012A1001

1) Check commutator for any sign of burns or rough surfaces or stepped wear. If wear is of a minor nature, correct it by using sand paper.

2) Run-out test

Check the commutator run-out and replace if it exceeds the limit.

Commutator run-out:

Standard

0.05 mm (0.0020 in), or less

Service limit

Less than 0.10 mm (0.0039 in)

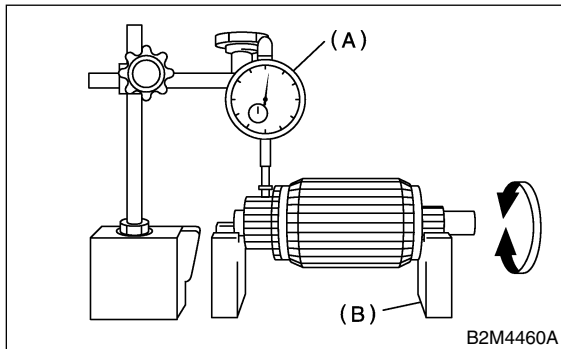

(A) Dial gauge
(B) Block

3) Depth of segment mold

Check the depth of segment mold.

Depth of segment mold X:

0.6 mm (0.024 in)

Limit

0.2 mm (0.008 in)

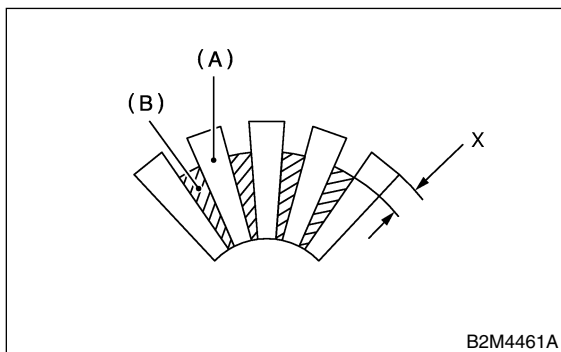

(A) Segment
(B) Mold

4) Armature short-circuit test

Check armature for short-circuit by placing it on growler tester. Hold a hacksaw blade against armature core while slowly rotating armature. A short-circuited armature will cause the blade to vibrate and to be attracted to core. If the hacksaw blade is attracted or vibrates, the armature, which is short-circuited, must be replaced or repaired.

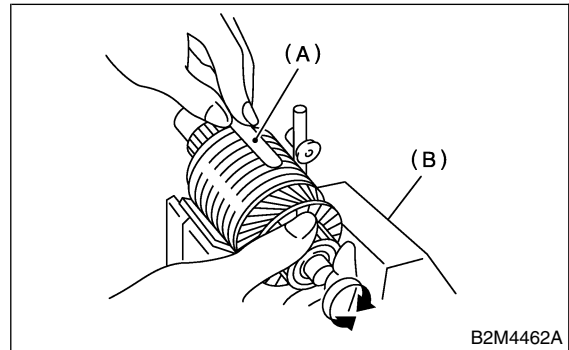

(A) Iron sheet
(B) Growler tester

5) Armature ground test

Using circuit tester, touch one probe to the commutator segment and the other to shaft. There should be resistance of 1 MΩ or more. If resistance is 1 Ω or less, armature is grounded.

Replace armature if it is grounded.

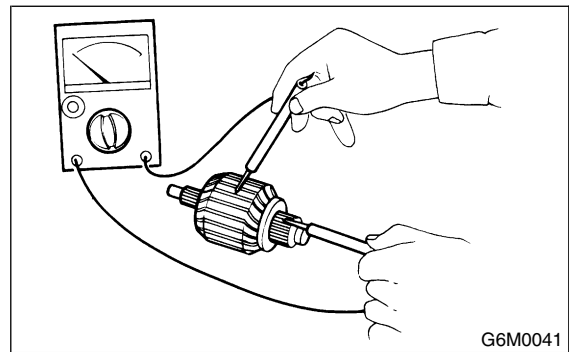

G6M0041

2. YOKE S149012A1002

Make sure pole is set in position.

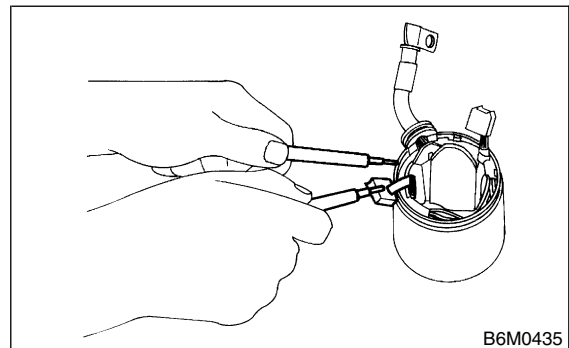

B6M0435

STARTER

3. OVERRUNNING CLUTCH S149012A1003

Inspect teeth of pinion for wear and damage. Replace if it is damaged. Rotate pinion in direction of rotation (clockwise). It should rotate smoothly. But in opposite direction, it should be locked.

CAUTION:

Do not clean overrunning clutch with oil to prevent grease from flowing out.

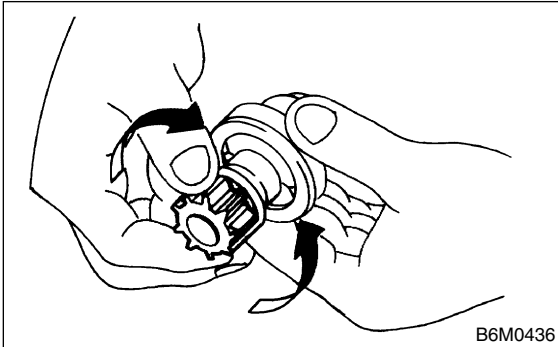

4. BRUSH AND BRUSH HOLDER S149012A1004

1) Brush length

Measure the brush length and replace if it exceeds the service limit.

Replace if abnormal wear or cracks are noticed.

Brush length:

Standard

17.0 mm (0.669 in)

Service limit

11.5 mm (0.453 in)

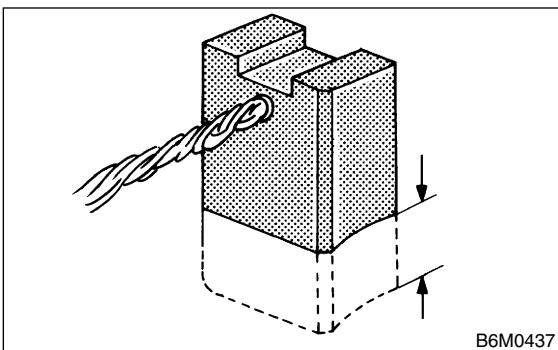

2) Brush movement

Be sure brush moves smoothly inside brush holder.

3) Insulation resistance of brush holder
Be sure there is resistance of 1 MΩ or more between brush holder and its plate.

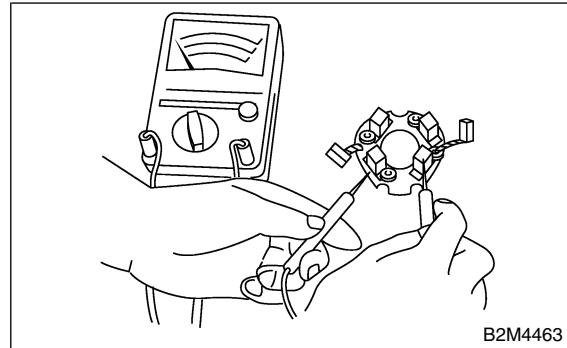

5. MAGNETIC SWITCH S149012A1005

CAUTION:

- The following magnetic switch tests should be performed with specified voltage applied.
- Each test should be conducted within 3 to 5 seconds. Power to be furnished should be one-half the rated voltage.

6. SWITCH ASSEMBLY S149012A1006

Be sure there is resistance of 1 Ω or less between terminals S and M, and between terminal S and ground. Use a circuit tester (set in "ohm"). Also check to be sure resistance is 1 MΩ or more between terminal M and B.

Terminal / Specified resistance:

S — M / 1Ω or less

S — Ground / 1Ω or less

M — B / 1 MΩ or more

