

CAMSHAFT DRIVE BELT

Periodic Maintenance Services

7. Camshaft Drive Belt SA07685

A: REPLACEMENT SA07685A20

- 1) Remove radiator fan <Ref. to CO-26, Radiator Main Fan and Fan Motor.> and air conditioner fan <Ref. to CO-29, Radiator Sub Fan and Fan Motor.>.
- 2) Remove V-belt cover.

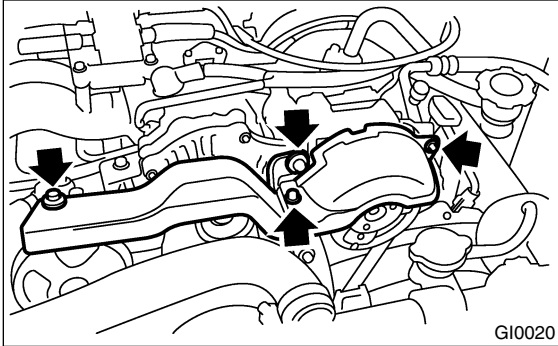

- 3) Remove V-belts. <Ref. to ME-42, V-belt.>
- 4) Remove air conditioning compressor drive belt tensioner.
- 5) Remove pulley bolt. To lock crankshaft use ST. ST 499977100 CRANKSHAFT PULLEY WRENCH

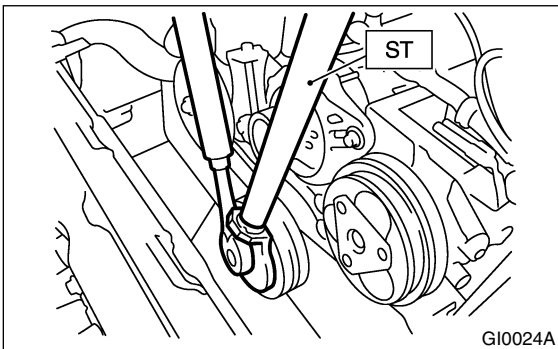

- 6) Remove crankshaft pulley.
- 7) Remove left side belt cover.
- 8) Remove front belt cover.

- 9) Turn crankshaft and align alignment marks on crankshaft, and left and right camshaft sprockets with notches of belt cover and cylinder block:
ST 499987500 CRANKSHAFT SOCKET

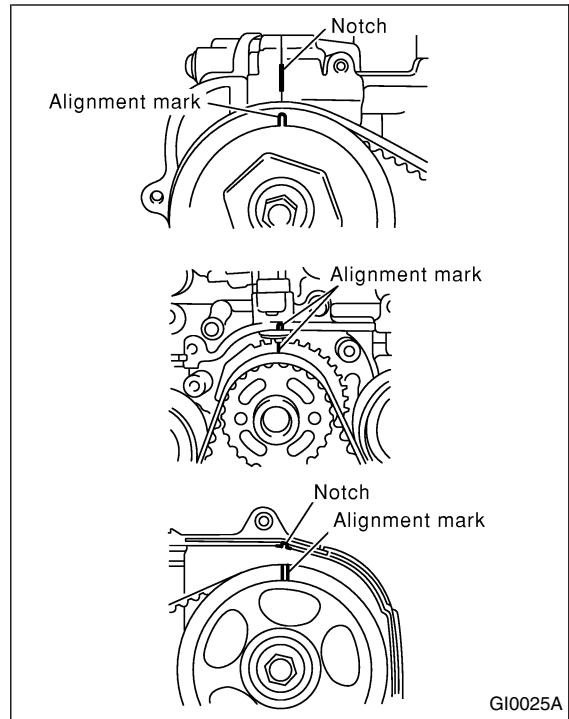

- 10) Remove belt idler.
- 11) Remove belt idler (No. 2).

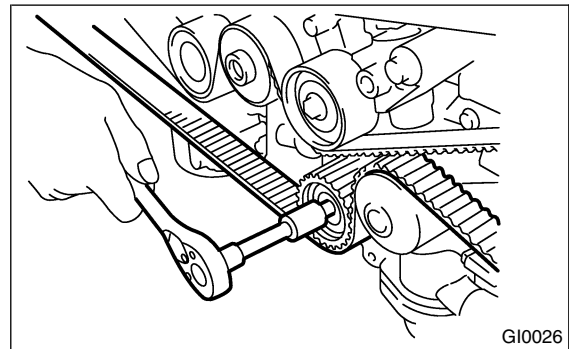

- 12) Remove timing belt.
- 13) Remove automatic belt tension adjuster assembly.

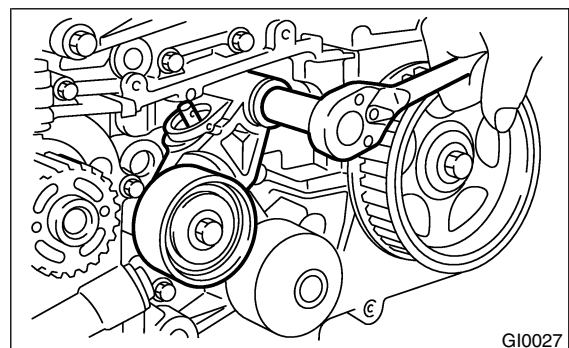

B: INSTALLATION SA07685A11

Install in the reverse order of removal.

NOTE:

When installing the timing belt, be sure to align all alignment marks on the belt with corresponding marks on the sprockets. If incorrectly installed, interference between pistons and valves may occur.

C: INSPECTION SA07685A10

- 1) Remove left and right timing belt covers.
- 2) While cranking engine at least four rotations, check timing belt back surface for cracks or damage. Replace faulty timing belt as needed.
- 3) Measure timing belt width *W*. If it is less than 27 mm (1.06 in), check idlers, tensioner, water pump pulley and cam sprocket to determine idler alignment (squareness). Replace worn timing belt.

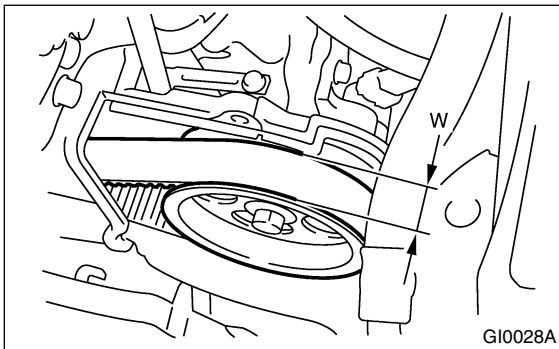

- 4) Install left and right timing belt covers.