

GENERAL DESCRIPTION

HVAC System (Heater, Ventilator and A/C)

1. General Description S701001

A: SPECIFICATIONS S701001E49

1. HEATER SYSTEM S701001E4901

Item		Specifications	Condition
Heating capacity		5.0 kW (4,300 kcal/h, 17,062 BTU/h) or more	<ul style="list-style-type: none"> ● Mode selector switch: HEAT ● Temperature control switch: FULL HOT ● Temperature difference between hot water and inlet air: 65°C (149°F) ● Hot water flow rate: 360 ℓ (95.1 US gal, 79.2 Imp gal)/h
Air flow rate		300 m ³ (10,593 cu ft)/h	Heat mode (FRESH), FULL HOT at 12.5 V
Max air flow rate		500 m ³ (17,655 cu ft)/h	<ul style="list-style-type: none"> ● Temperature control switch: FULL COLD ● Blower fan speed: 4th position ● Mode selector lever: RECIRC
Heater core size (height × length × width)		193.5 × 152 × 35.0 mm (7.62 × 5.98 × 1.378 in)	—
Blower motor	Type	Magnet motor 220 W or less	at 12 V
	Fan type and size (diameter × width)	Sirocco fan type 150 × 75 mm (5.91 × 2.95 in)	—

GENERAL DESCRIPTION

HVAC System (Heater, Ventilator and A/C)

2. A/C SYSTEM (4 CYLINDER) S701001E4903

Item		Specifications	
Type of air conditioner		Reheat air-mix type	
Cooling capacity		5.2 kW (4,471 kcal/h, 17,741 BTU/h)	
Refrigerant		HFC-134a (CH ₂ FCF ₃) [0.65±0.05 kg (1.43±0.11 lb)]	
Compressor	Type	5-vane rotary, fix volume (DKV-14G)	
	Discharge	140 cm ³ (8.54 cu in)/rev	
	Max. permissible speed	7,000 rpm	
Magnet clutch	Type	Dry, single-disc type	
	Power consumption	45 W	
	Type of belt	V-Ribbed 4 PK	
	Pulley dia. (effective dia.)	125 mm (4.92 in)	
	Pulley ratio	1.064	
Condenser	Type	Corrugated fin (Multi-flow)	
	Core face area	0.21 m ² (2.26 sq ft)	
	Core thickness	24 mm (0.94 in)	
	Radiation area	6.52 m ² (70 sq ft)	
Receiver drier	Effective inner capacity	250 cm ³ (15.26 cu in)	
Expansion valve	Type	Internal equalizing	
Evaporator	Type	Single tank	
	Dimensions (W × H × T)	235 × 224 × 60 mm (9.25 × 8.82 × 2.36 in)	
Blower fan	Fan type	Sirocco fan	
	Outer diameter × width	150 × 75 mm (5.91 × 2.95 in)	
	Power consumption	220 W at 12 V	
Condenser fan (Sub fan)	Motor type	Magnet	
	Power consumption	75 W at 12 V	
	Fan outer diameter	300 mm (11.81 in)	
Radiator fan (Main fan)	Motor type	Magnet	
	Power consumption	75 W at 12 V	
	Fan outer diameter	300 mm (11.81 in)	
Idling speed (A/C ON)	MPFI model	850±100 rpm	
Dual switch (Pressure switch)	Low-pressure switch operating pressure	ON → OFF	177±25 kPa (1.80±0.25 kg/cm ² , 25.6±3.6 psi)
		OFF → ON	216 ⁺³⁹ / ₋₂₅ kPa (2.2 ^{+0.4} / _{-0.25} kg/cm ² , 31 ^{+5.7} / _{-3.6} psi)
	High-pressure switch operating pressure	ON → OFF	2,942±196 kPa (30±2 kg/cm ² , 427±28 psi)
		DIFF	588±196 kPa (6±2 kg/cm ² , 85±28 psi)
Thermo control amplifier working temperature (Evaporator outlet air)	<p>Diff. 3.0±0.3°C (37±0.5°F)</p> <p>OFF ————— 1.5±0.5°C (35±0.9°F) ————— ON</p>		

B4M2237A

GENERAL DESCRIPTION

HVAC System (Heater, Ventilator and A/C)

3. A/C SYSTEM (6 CYLINDER) S701001E4904

Item		Specifications	
Type of air conditioner		Reheat air-mix type	
Cooling capacity		5.2 kW (4,471 kcal/h, 17,741 BTU/h)	
Refrigerant		HFC-134a (CH ₂ FCF ₃) [0.65±0.05 kg (1.43±0.11 lb)]	
Compressor	Type	5-vane rotary, fix volume (DKV-14G)	
	Discharge	140 cm ³ (8.54 cu in)/rev	
	Max. permissible speed	7,000 rpm	
Magnet clutch	Type	Dry, single-disc type	
	Power consumption	38 W	
	Type of belt	V-Ribbed 6 PK	
	Pulley dia. (effective dia.)	125 mm (4.92 in)	
	Pulley ratio	1.064	
Condenser	Type	Corrugated fin (Multi-flow)	
	Core face area	0.22 m ² (2.37 sq ft)	
	Core thickness	24 mm (0.94 in)	
	Radiation area	6.52 m ² (70 sq ft)	
Receiver drier	Effective inner capacity	250 cm ³ (15.26 cu in)	
Expansion valve	Type	Internal equalizing	
Evaporator	Type	Single tank	
	Dimensions (W × H × T)	235 × 224 × 60 mm (9.25 × 8.82 × 2.36 in)	
Blower fan	Fan type	Sirocco fan	
	Outer diameter × width	150 × 75 mm (5.91 × 2.95 in)	
	Power consumption	220 W at 12 V	
Condenser fan (Sub fan)	Motor type	Magnet	
	Power consumption	120 W at 12 V	
	Fan outer diameter	320 mm (12.60 in)	
Radiator fan (Main fan)	Motor type	Magnet	
	Power consumption	120 W at 12 V	
	Fan outer diameter	320 mm (12.60 in)	
Idling speed (A/C ON)	MPFI model	850±100 rpm	
Dual switch (Pressure switch)	Low-pressure switch operating pressure	ON → OFF	177±25 kPa (1.80±0.25 kg/cm ² , 25.6±3.6 psi)
		OFF → ON	216 ⁺³⁹ / ₋₂₅ kPa (2.2 ^{+0.4} / _{-0.25} kg/cm ² , 31 ^{+5.7} / _{-3.6} psi)
	High-pressure switch operating pressure	ON → OFF	2,942±196 kPa (30±2 kg/cm ² , 427±28 psi)
		DIFF	588±196 kPa (6±2 kg/cm ² , 85±28 psi)
Thermo control amplifier working temperature (Evaporator outlet air)	<p style="text-align: center;"> OFF ————— 1.5±0.5°C (35±0.9°F) ————— ON Diff. 3.0±0.3°C (37±0.5°F) </p>		

B4M2237A

GENERAL DESCRIPTION

HVAC System (Heater, Ventilator and A/C)

B: COMPONENT S701001A05

1. HEATER UNIT S701001A0501

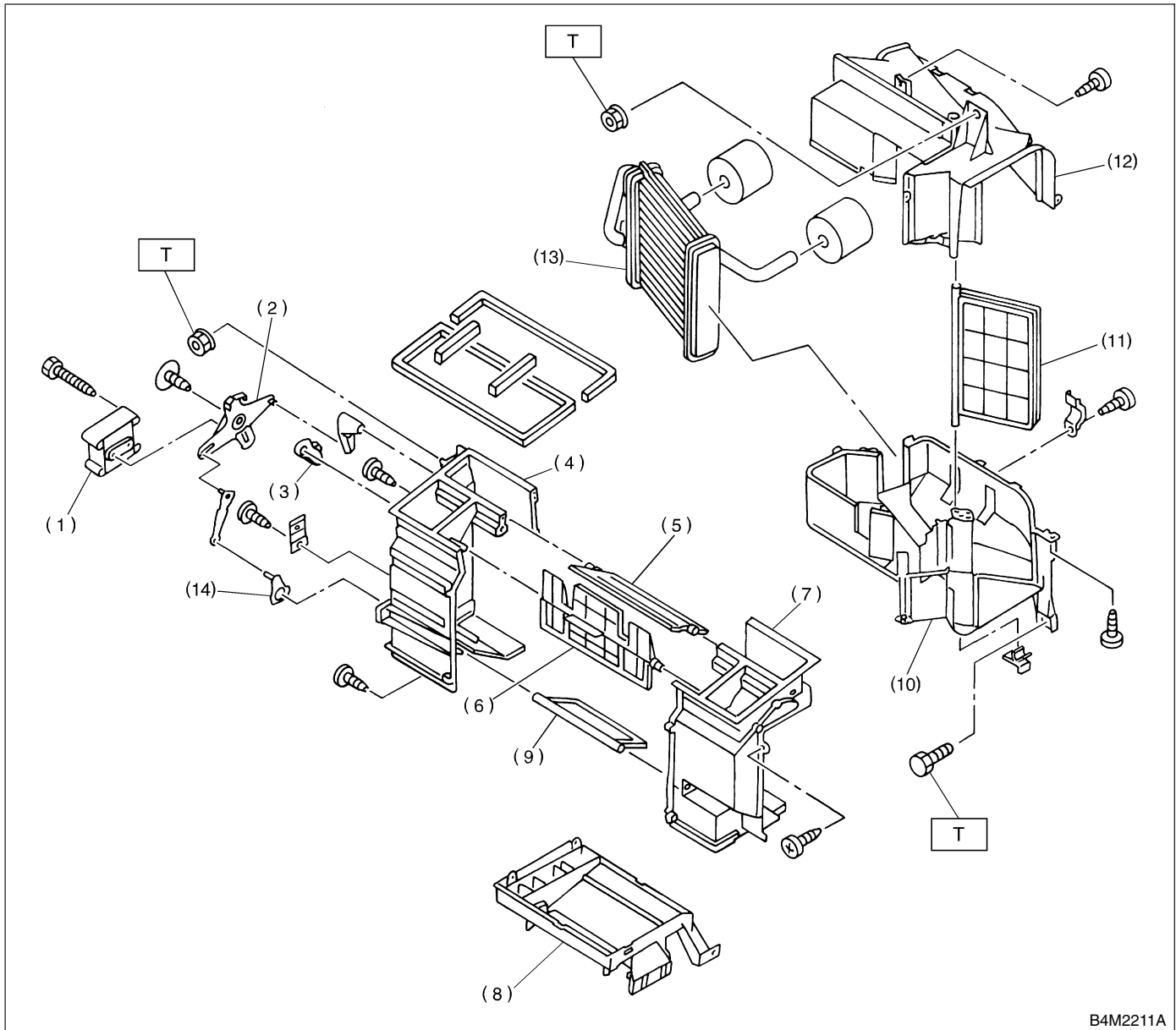

- (1) Vent door actuator
- (2) Side link
- (3) Vent door lever
- (4) Case A
- (5) DEF door
- (6) Vent door

- (7) Case B
- (8) Foot duct
- (9) Foot door
- (10) Case D
- (11) Mix door
- (12) Case C

- (13) Heater core
- (14) Foot door lever

Tightening torque: N-m (kgf-m, ft-lb)
T: 7.35 (0.750, 5.421)

GENERAL DESCRIPTION

HVAC System (Heater, Ventilator and A/C)

2. INTAKE UNIT S701001A0502

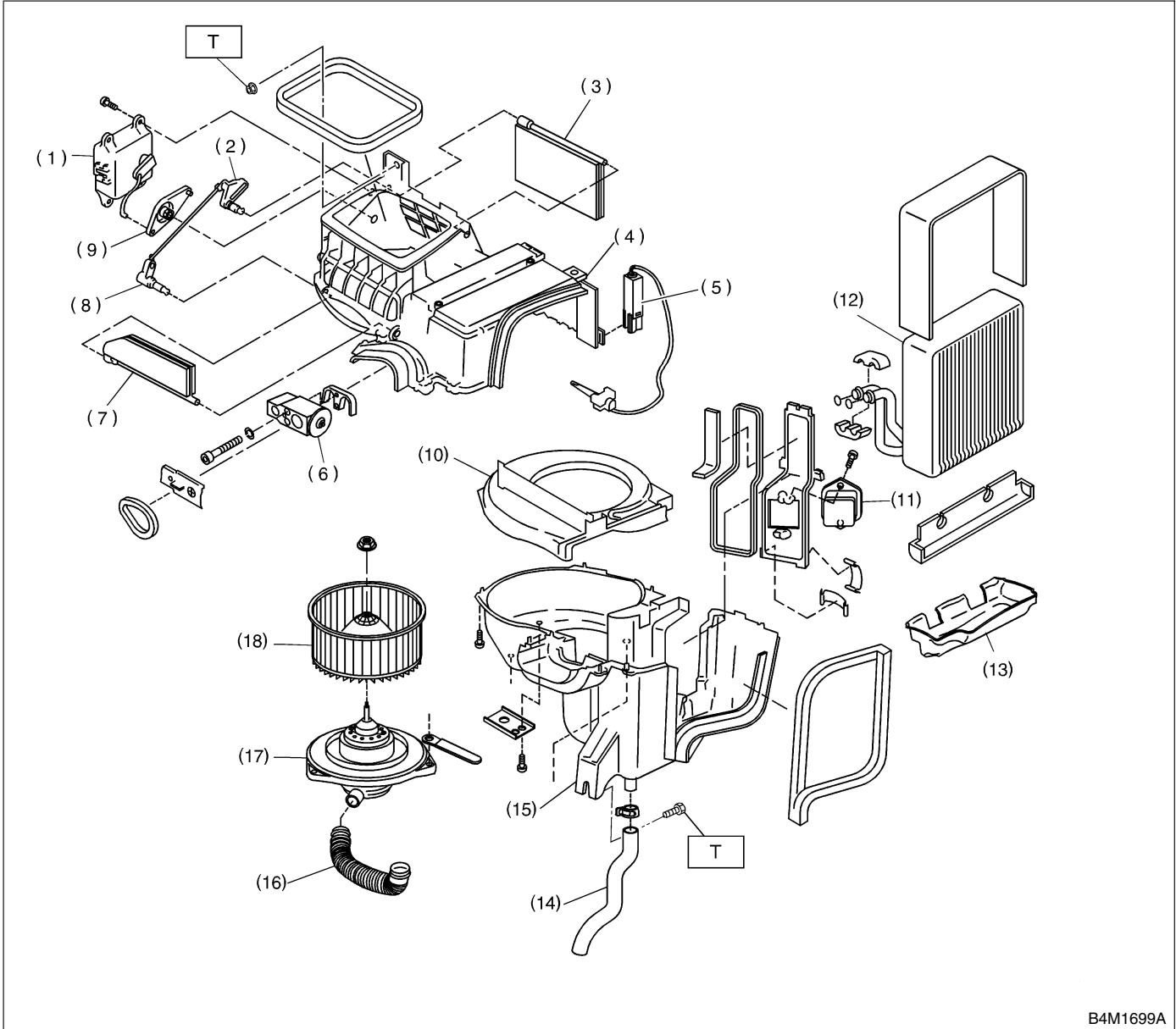

B4M1699A

- | | | |
|--|---------------------------------------|-----------------------------|
| (1) Intake door actuator | (8) Lever (B) | (15) Intake unit case lower |
| (2) Lever (A) | (9) Lever (C) | (16) Aspirator pipe |
| (3) Door (A) | (10) Blower plate | (17) Blower motor |
| (4) Intake unit case upper | (11) Resistor | (18) Fan |
| (5) Thermistor (With A/C model) | (12) Evaporator (With A/C model) | |
| (6) Block expansion valve (With A/C model) | (13) Evaporator case (With A/C model) | |
| (7) Door (B) | (14) Drain hose | |

Tightening torque: N·m (kgf·m, ft·lb)

T: 7.4 (0.75, 5.4)

GENERAL DESCRIPTION

HVAC System (Heater, Ventilator and A/C)

3. CONTROL UNIT (MANUAL A/C) S701001A0507

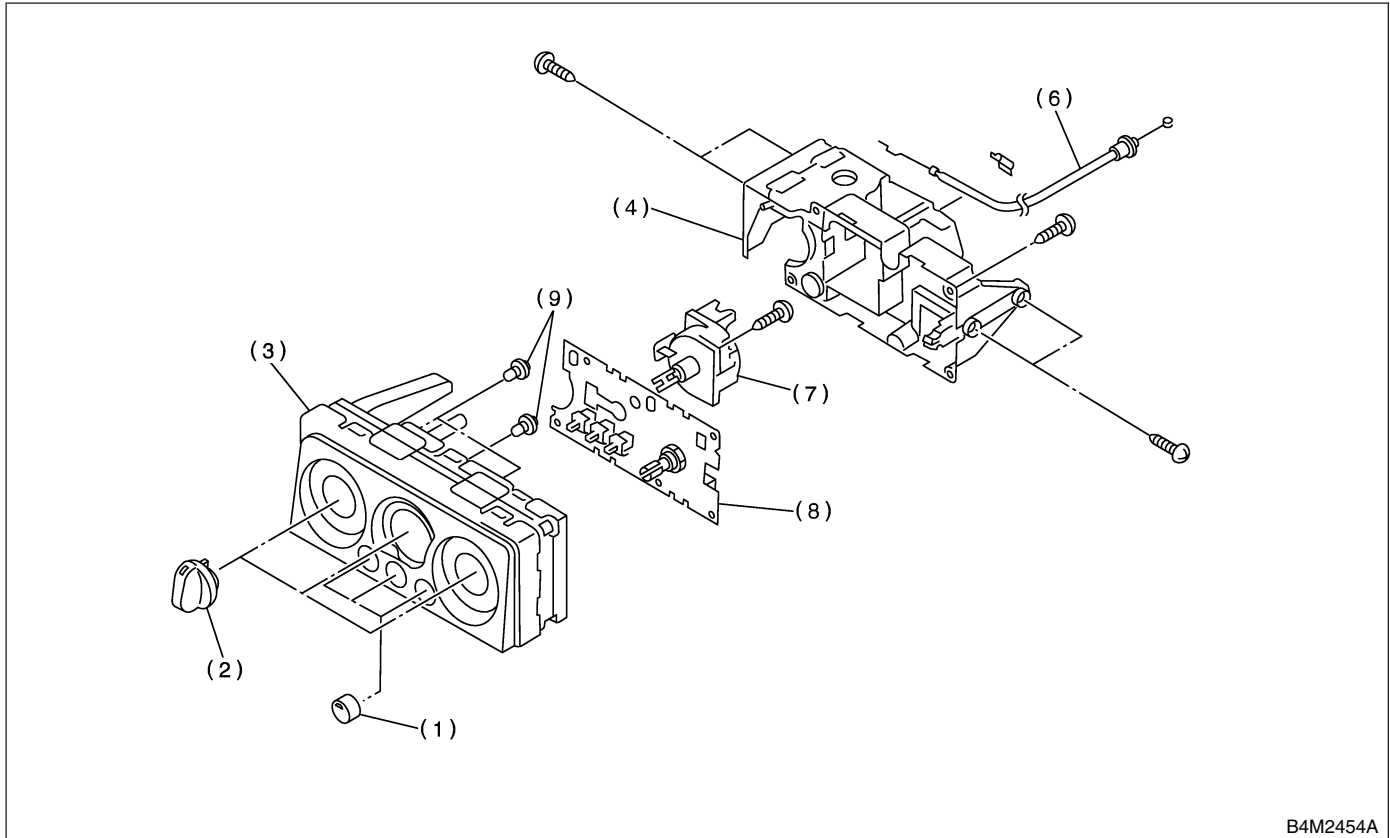

B4M2454A

- | | | |
|------------------------|-------------------------------|---------------------|
| (1) Switch | (4) Base unit | (7) Fan switch ASSY |
| (2) Control dial knob | (5) Cover | (8) Circuit ASSY |
| (3) Control panel ASSY | (6) Temperature control cable | (9) Bulb |

GENERAL DESCRIPTION

HVAC System (Heater, Ventilator and A/C)

4. CONTROL UNIT (AUTO A/C) S701001A0508

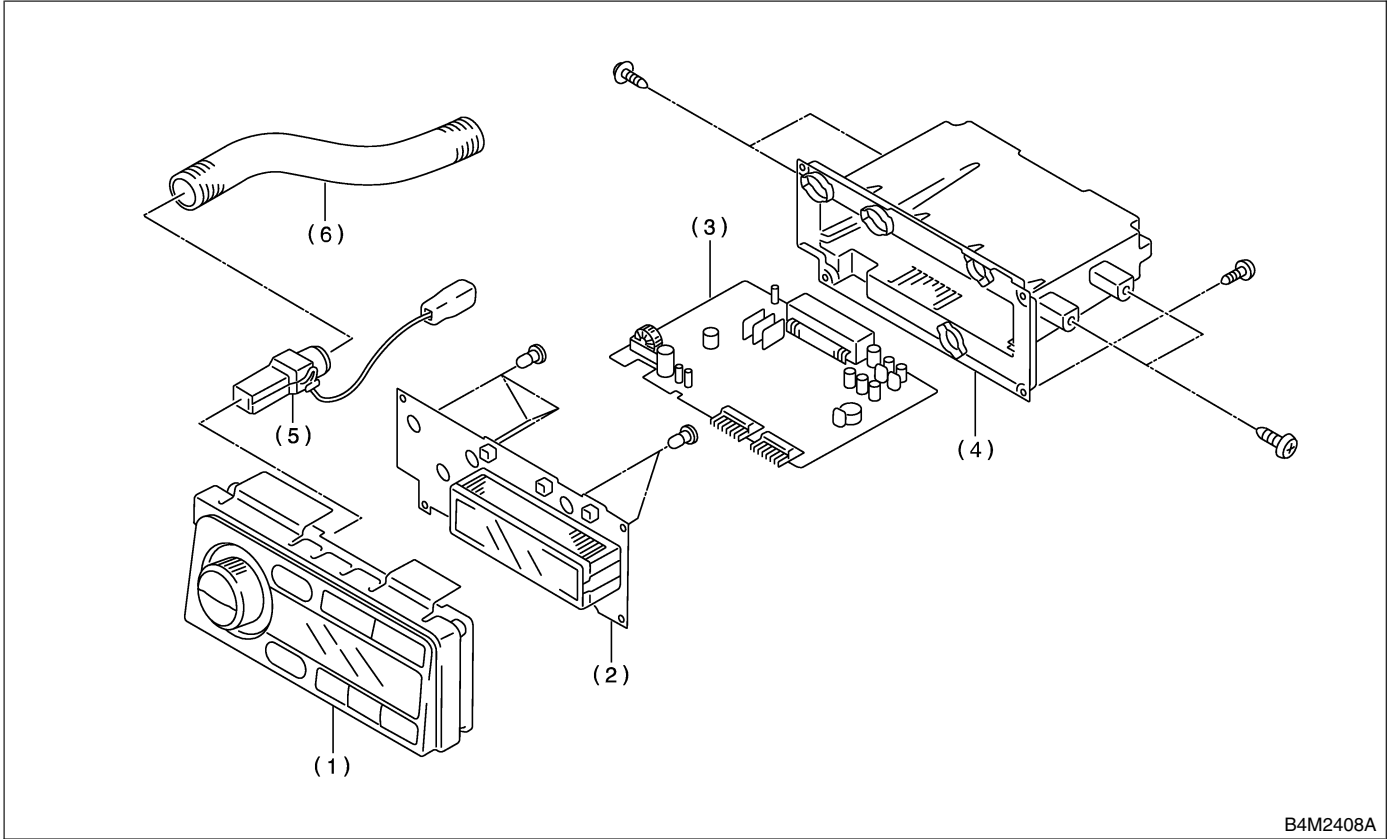

(1) Control panel
(2) Circuit ASSY

(3) Electronic control unit
(4) Control case

(5) In-car sensor
(6) Aspirator hose

GENERAL DESCRIPTION

HVAC System (Heater, Ventilator and A/C)

5. AIR CONDITIONING UNIT S701001A0504

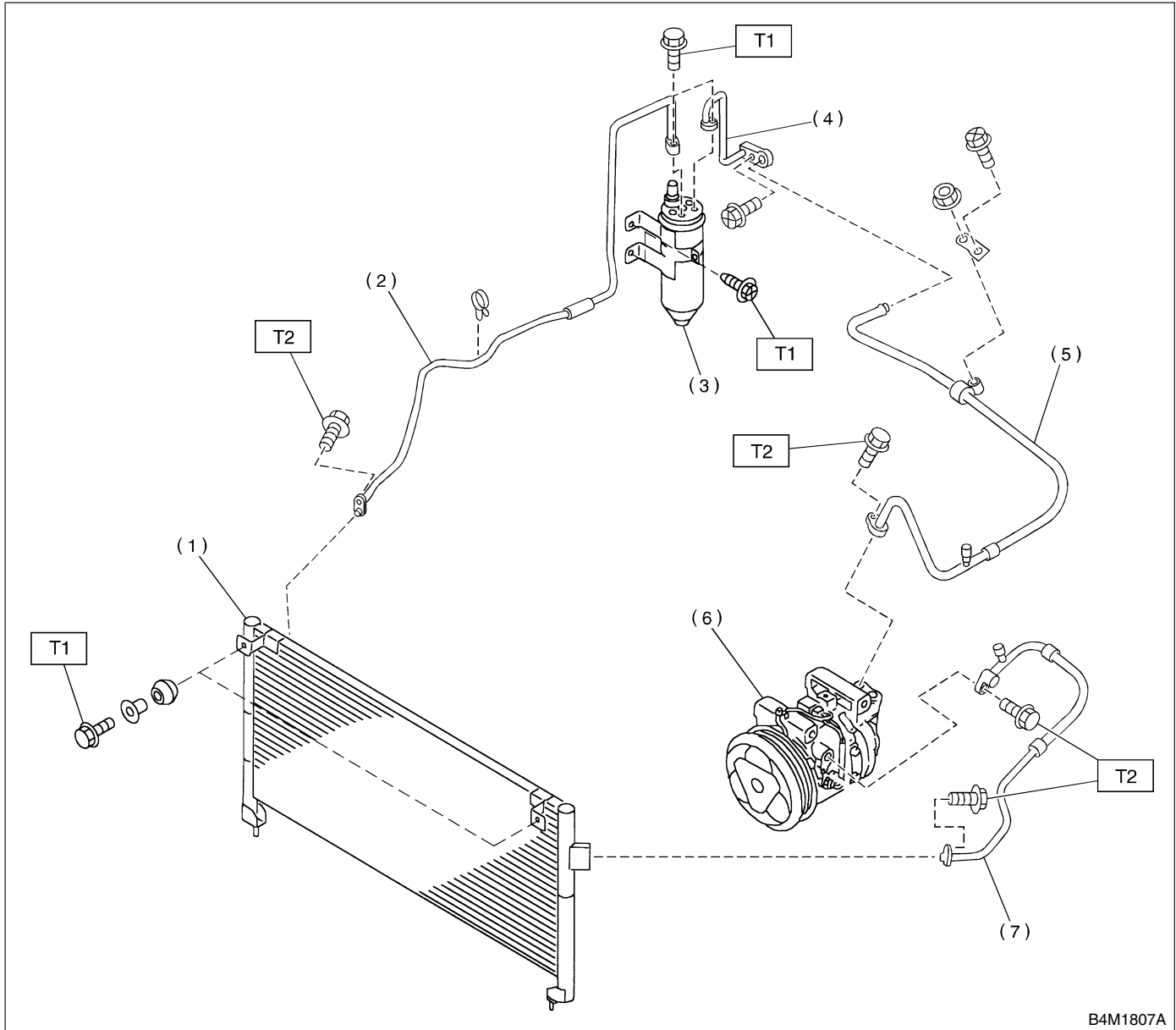

- | | |
|---------------------------------------|--------------------------|
| (1) Condenser | (5) Hose (Low-pressure) |
| (2) Pipe (Condenser — Receiver drier) | (6) Compressor |
| (3) Receiver drier | (7) Hose (High-pressure) |
| (4) Pipe (Receiver drier — C/unit) | |

Tightening torque: N·m (kgf·m, ft·lb)

T1: 7.4 (0.75, 5.4)

T2: 15 (1.5, 10.8)

GENERAL DESCRIPTION

HVAC System (Heater, Ventilator and A/C)

6. INTAKE UNIT WITH EVAPORATOR

S701001A0505

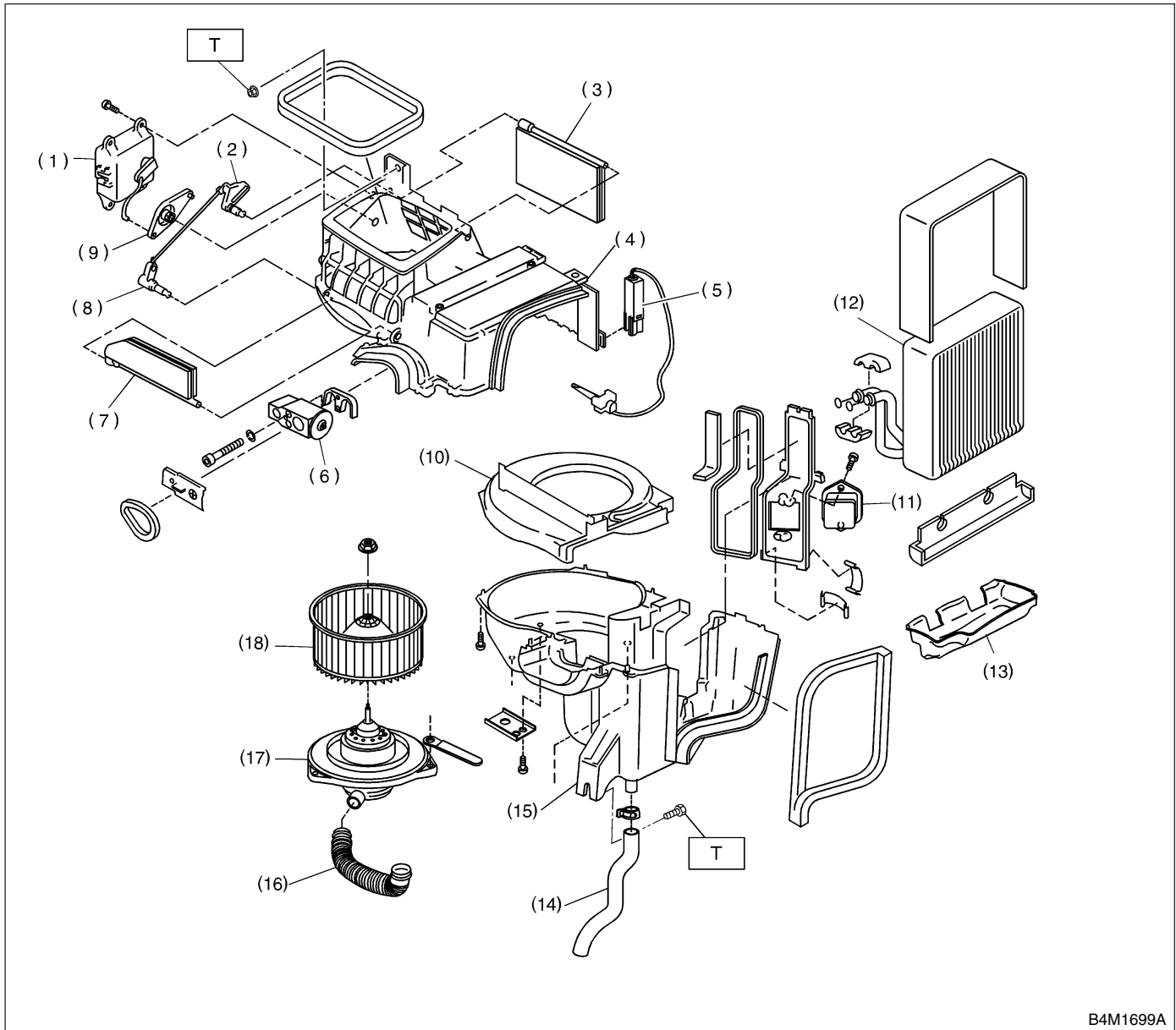

B4M1699A

- | | | |
|--|---------------------------------------|-----------------------------|
| (1) Intake door actuator | (8) Lever (B) | (15) Intake unit case lower |
| (2) Lever (A) | (9) Lever (C) | (16) Aspirator pipe |
| (3) Door (A) | (10) Blower plate | (17) Blower motor |
| (4) Intake unit case upper | (11) Resistor | (18) Fan |
| (5) Thermistor (With A/C model) | (12) Evaporator (With A/C model) | |
| (6) Block expansion valve (With A/C model) | (13) Evaporator case (With A/C model) | |
| (7) Door (B) | (14) Drain hose | |

Tightening torque: N·m (kgf·m, ft·lb)
T: 7.35 (0.750, 5.421)

GENERAL DESCRIPTION

HVAC System (Heater, Ventilator and A/C)

7. COMPRESSOR S701001A0506

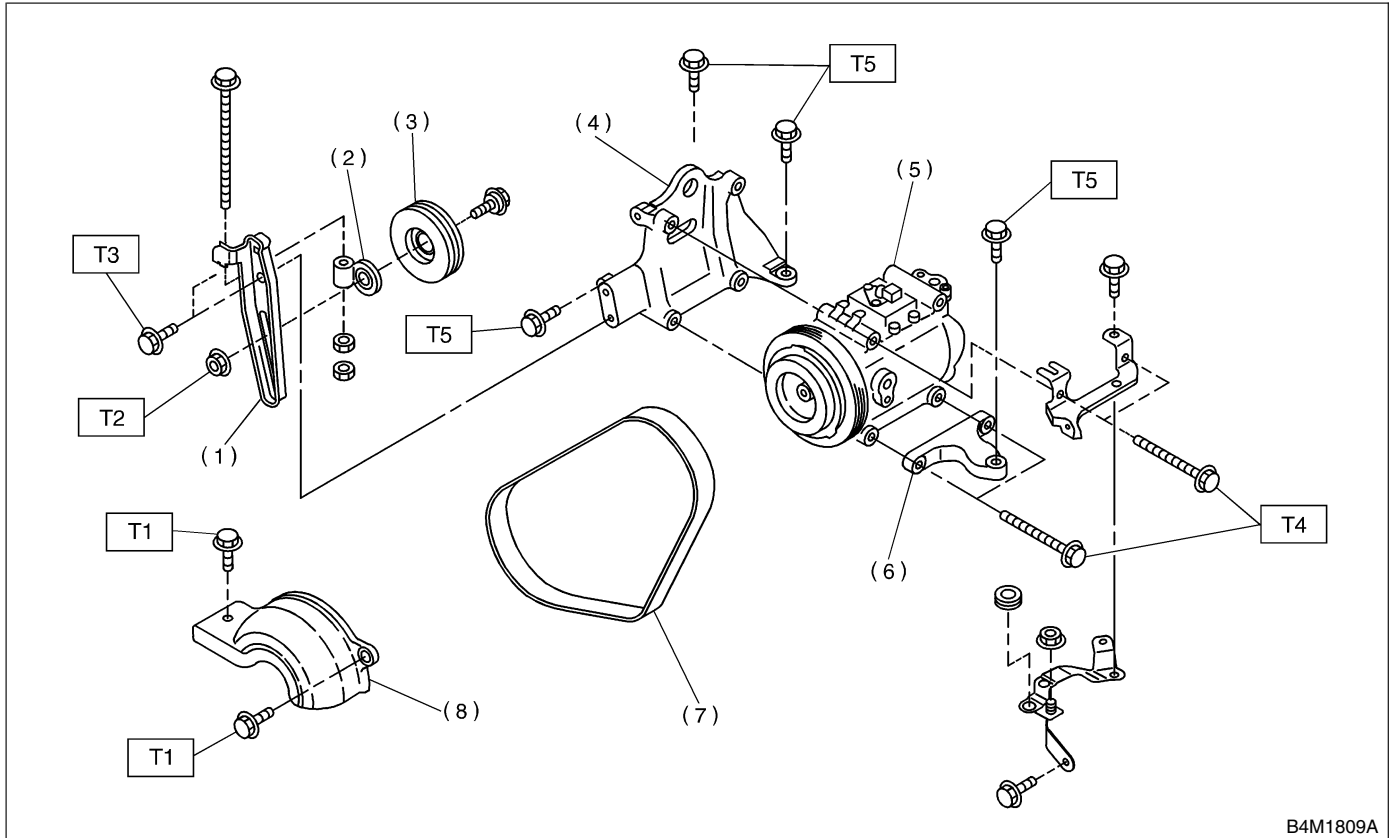

- (1) Idler pulley bracket
- (2) Idler pulley adjuster
- (3) Idler pulley
- (4) Compressor bracket upper
- (5) Compressor
- (6) Compressor bracket lower
- (7) V-belt
- (8) Compressor belt cover

Tightening torque: N-m (kgf-m, ft-lb)

T1: 7.4 (0.75, 5.4)

T2: 23 (2.3, 17)

T3: 23.0 (2.35, 17.0)

T4: 28.9 (2.95, 21.3)

T5: 35 (3.6, 26)

GENERAL DESCRIPTION

HVAC System (Heater, Ventilator and A/C)

C: CAUTION S701001A03

1. HFC-134a A/C SYSTEM S701001A0301

- Unlike the old conventional HFC-12 system components, the cooling system components for the HFC-134a system such as the refrigerant and compressor oil are incompatible.
- Vehicles with the HFC-134a system can be identified by the label “A” attached to the vehicle. Before maintenance, check which A/C system is installed in the vehicle.

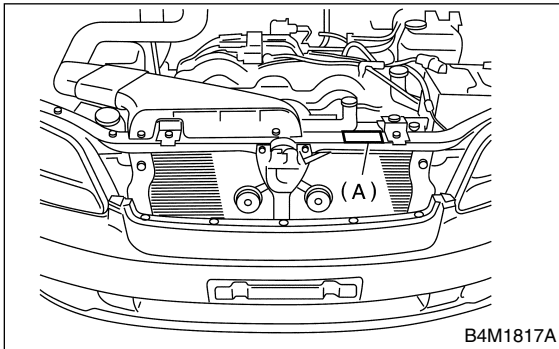

2. COMPRESSOR OIL S701001A0302

- HFC-134a compressor oil has no compatibility with that for R12 system.
- Use only the manufacturer-authorized compressor oil for the HFC-134a system; only use ZXL200PG.
- Do not mix multiple compressor oils. If HFC-12 compressor oil is used in a HFC-134a A/C system, the compressor may become stuck due to poor lubrication, or the refrigerant may leak due to swelling of rubber parts. On the other hand, if HFC-134a compressor oil is used in a HFC-12 A/C system, the durability of the A/C system will be lowered.
- HFC-134a compressor oil is very hygroscopic. When replacing or installing/removing A/C parts, immediately isolate the oil from the atmosphere using a plug or tape. In order to avoid moisture, store the oil in a container with its cap tightly closed.

3. REFRIGERANT S701001A0303

- The HFC-12 refrigerant cannot be used in the HFC-134a A/C system. The HFC-134a refrigerant, also, cannot be used in the HFC-12 A/C system.
- If an incorrect or no refrigerant is used, poor lubrication will result and the compressor itself may be damaged.

4. HANDLING OF REFRIGERANT S701001A0304

- The refrigerant boils at approx. -30°C (-22°F). When handling it, be sure to wear safety goggles and protective gloves. Direct contact of the refrigerant with skin may cause frostbite. If the refrigerant gets into your eye, avoid rubbing your eyes with your hands. Wash your eye with plenty of water, and receive medical treatment from an eye doctor.
- Do not heat a service can. If a service can is directly heated, or put into boiling water, the inside pressure will become extremely high. This may cause the can to explode. If a service can must be warmed up, use hot water in 40°C (104°F) max.
- Do not drop or impact a service can. (Observe the precautions and operation procedure described on the refrigerant can.)
- When the engine is running, do not open the high-pressure valve of the manifold gauge. The high-pressure gas will back-flow resulting in an explosion of the can.
- The refrigerant is non-toxic and harmless under normal operating circumstance, but it may change to phosgene (a noxious fume) under open flames or high temperatures (caused by a cigarette or heater).
- Provide good ventilation and do not work in a closed area.
- Never perform a gas leak test using a halide torch-type leak tester.
- In order to avoid destroying the ozone layer, prevent HFC-134a from being released into the atmosphere. Using a refrigerant recovery system, discharge and reuse it.

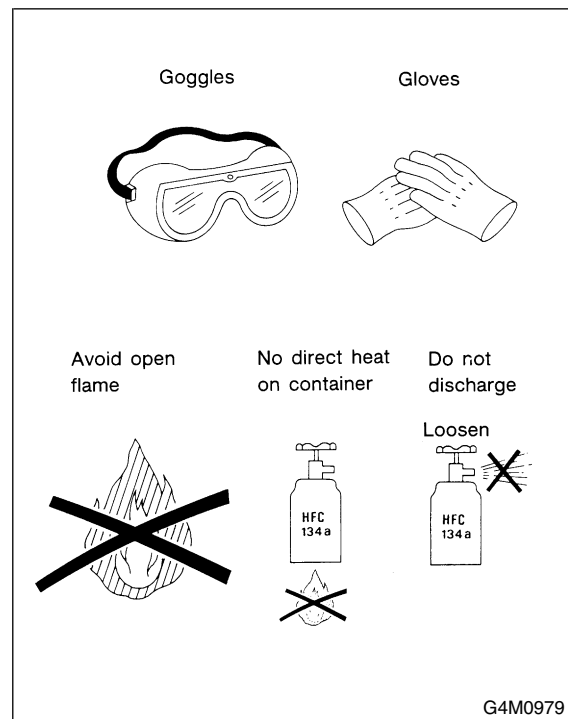

GENERAL DESCRIPTION

HVAC System (Heater, Ventilator and A/C)

5. O-RING CONNECTIONS S701001A0305

- Use new O-rings.
- In order to keep the O-rings free of lint which will cause a refrigerant gas leak, perform operations without gloves and shop towels.
- Apply the compressor oil to the O-rings to avoid sticking, then install them.
- Use a torque wrench to tighten the O-ring fittings: Over-tightening will damage the O-ring and tube end distortion.
- If the operation is interrupted before completing a pipe connection, recap the tubes, components, and fittings with a plug or tape to prevent contamination from entering.

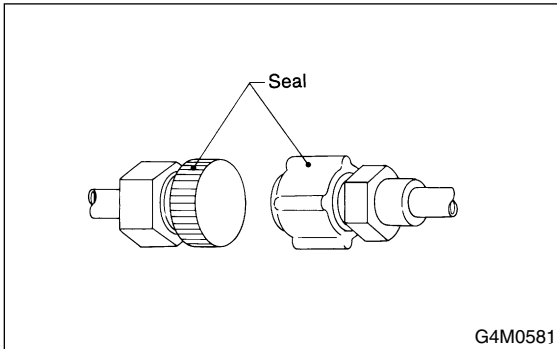

- Visually check the surfaces and mating surfaces of O-rings, threads, and connecting points. If a failure is found, replace the applicable parts.
- Install the O-rings at right angle to the tube beads.

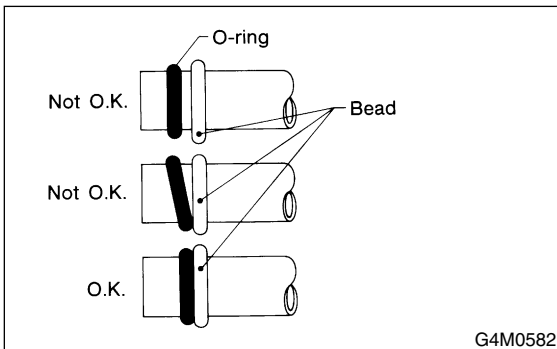

- Use the oil specified in the service manual to lubricate the O-rings. Apply the oil to the top and sides of the O-rings before installation. Apply the oil to the area including the O-rings and tube beads.

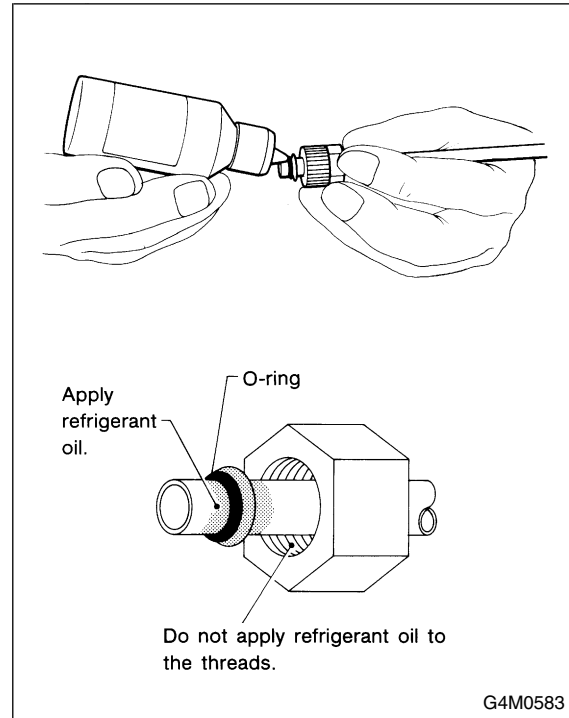

- When connecting hoses or pipes, use 2 wrenches (a torque wrench for tightening). While securing one side with a wrench, tighten the other side to the specified torque with a torque wrench. If only one wrench is used to tighten, the tightening torque will be excessive or insufficient. This may cause a pipe distortion or gas leak, resulting in damage to hoses and pipes.
- After tightening, using a clean shop towel to remove excess oil from the connections and any oil which may have run on the vehicle body or other parts.
- If any leakage is suspected after tightening, do not retighten the connections, Disconnect the connections, remove the O-rings, and check the O-rings, threads, and connections.

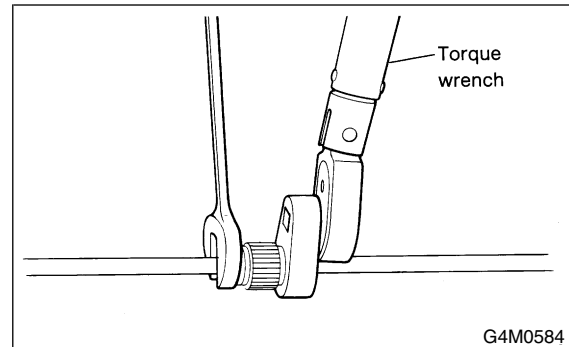

GENERAL DESCRIPTION

HVAC System (Heater, Ventilator and A/C)

D: PREPARATION TOOL S701001A17

CAUTION:

When working on vehicles with the HFC-134a system, only use HFC-134a specified tools and parts. Do not mix with CFC-12 tools and parts. If HFC-134a and CFC-12 refrigerant or compressor oil is mixed, poor lubrication will result and the compressor itself may be destroyed. In order to help prevent mixing HFC-134a and CFC-12 parts and liquid, the tool and screw type and the type of service valves used are different. The gas leak detectors for the HFC-134a and CFC-12 systems must also not be interchanged.

	HFC-134a	CFC-12
Tool & screw type	Millimeter size	Inch size
Valve type	Quick joint type	Screw-in type

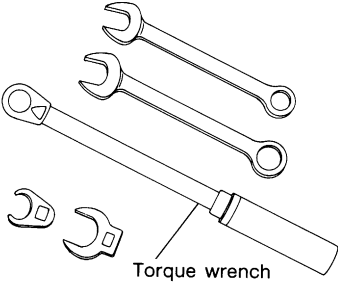
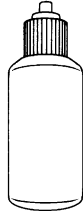
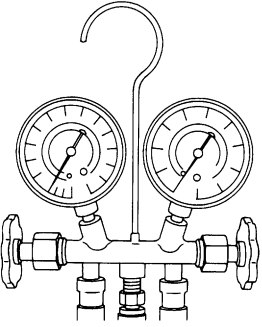
Tools and Equipment	Description
<p>Wrench</p> <p>Various WRENCHES will be required to service any A/C system. A 7 to 40 N-m (0.7 to 4.1 kg-m, 5 to 30 ft-lb) torque wrench with various crowfoot wrenches will be needed. Open end or flare nut wrenches will be needed for back-up on the tube and hose fittings.</p>	 <p style="text-align: right;">G4M0571</p>
<p>Applicator bottle</p> <p>A small APPLICATOR BOTTLE is recommended to apply refrigerant oil to the various parts. They can be obtained at a hardware or drug store.</p>	 <p style="text-align: right;">G4M0572</p>
<p>Manifold gauge set</p> <p>A MANIFOLD GAUGE SET (with hoses) can be obtained from either a commercial refrigeration supply house or from an auto shop equipment supplier.</p>	 <p style="text-align: right;">G4M0573</p>

GENERAL DESCRIPTION

HVAC System (Heater, Ventilator and A/C)

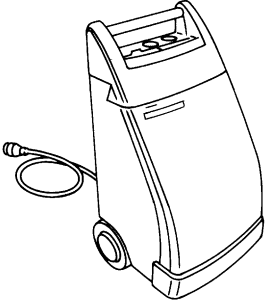
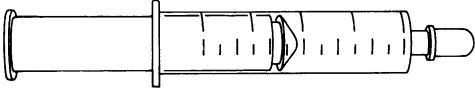
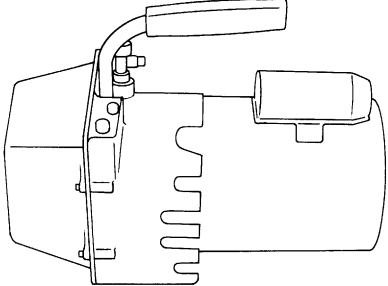
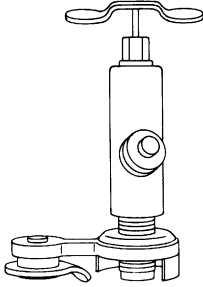
Tools and Equipment	Description
<p>Refrigerant recovery system</p> <p>A REFRIGERANT RECOVERY SYSTEM is used for the recovery and reuse of A/C system refrigerant after contaminants and moisture have been removed from the refrigerant.</p>	 <p style="text-align: right;">G4M0574</p>
<p>Syringe</p> <p>A graduated plastic SYRINGE will be needed to add oil back into the system. The syringe can be found at a pharmacy or drug store.</p>	 <p style="text-align: right;">G4M0575</p>
<p>Vacuum pump</p> <p>A VACUUM PUMP (in good working condition) is necessary, and may be obtained from either a commercial refrigeration supply house or an automotive equipment supplier.</p>	 <p style="text-align: right;">G4M0576</p>
<p>Can tap</p> <p>A CAN TAP for the 397 g (14 oz) can is available from an auto supply store.</p>	 <p style="text-align: right;">G4M0577</p>

GENERAL DESCRIPTION

HVAC System (Heater, Ventilator and A/C)

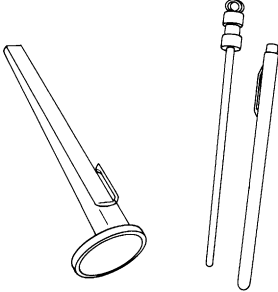
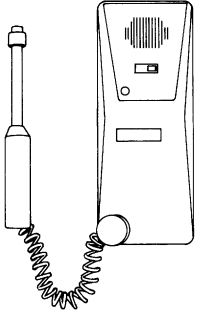
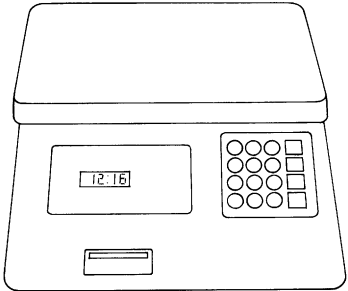
Tools and Equipment	Description
<p>Thermometer</p> <p>Pocket THERMOMETERS are available from either industrial hardware store or commercial refrigeration supply houses.</p>	 <p>G4M0578</p>
<p>Electronic leak detector</p> <p>An ELECTRONIC LEAK DETECTOR can be obtained from either a specialty tool supply or an A/C equipment supplier.</p>	 <p>G4M0579</p>
<p>Weight scale</p> <p>A WEIGHT SCALE such as an electronic charging scale or a bathroom scale with digital display will be needed if a 13.6 kg (30 lb) refrigerant container is used.</p>	 <p>G4M0580</p>

GENERAL DESCRIPTION

HVAC System (Heater, Ventilator and A/C)

1. General Description S701001

A: SPECIFICATIONS S701001E49

1. HEATER SYSTEM S701001E4901

Item		Specifications	Condition
Heating capacity		5.0 kW (4,300 kcal/h, 17,062 BTU/h) or more	<ul style="list-style-type: none"> ● Mode selector switch: HEAT ● Temperature control switch: FULL HOT ● Temperature difference between hot water and inlet air: 65°C (149°F) ● Hot water flow rate: 360 ℓ (95.1 US gal, 79.2 Imp gal)/h
Air flow rate		300 m ³ (10,593 cu ft)/h	Heat mode (FRESH), FULL HOT at 12.5 V
Max air flow rate		500 m ³ (17,655 cu ft)/h	<ul style="list-style-type: none"> ● Temperature control switch: FULL COLD ● Blower fan speed: 4th position ● Mode selector lever: RECIRC
Heater core size (height × length × width)		193.5 × 152 × 35.0 mm (7.62 × 5.98 × 1.378 in)	—
Blower motor	Type	Magnet motor 220 W or less	at 12 V
	Fan type and size (diameter × width)	Sirocco fan type 150 × 75 mm (5.91 × 2.95 in)	—

GENERAL DESCRIPTION

HVAC System (Heater, Ventilator and A/C)

2. A/C SYSTEM (4 CYLINDER) S701001E4903

Item		Specifications	
Type of air conditioner		Reheat air-mix type	
Cooling capacity		5.2 kW (4,471 kcal/h, 17,741 BTU/h)	
Refrigerant		HFC-134a (CH ₂ FCF ₃) [0.65±0.05 kg (1.43±0.11 lb)]	
Compressor	Type	5-vane rotary, fix volume (DKV-14G)	
	Discharge	140 cm ³ (8.54 cu in)/rev	
	Max. permissible speed	7,000 rpm	
Magnet clutch	Type	Dry, single-disc type	
	Power consumption	45 W	
	Type of belt	V-Ribbed 4 PK	
	Pulley dia. (effective dia.)	125 mm (4.92 in)	
	Pulley ratio	1.064	
Condenser	Type	Corrugated fin (Multi-flow)	
	Core face area	0.21 m ² (2.26 sq ft)	
	Core thickness	24 mm (0.94 in)	
	Radiation area	6.52 m ² (70 sq ft)	
Receiver drier	Effective inner capacity	250 cm ³ (15.26 cu in)	
Expansion valve	Type	Internal equalizing	
Evaporator	Type	Single tank	
	Dimensions (W × H × T)	235 × 224 × 60 mm (9.25 × 8.82 × 2.36 in)	
Blower fan	Fan type	Sirocco fan	
	Outer diameter × width	150 × 75 mm (5.91 × 2.95 in)	
	Power consumption	220 W at 12 V	
Condenser fan (Sub fan)	Motor type	Magnet	
	Power consumption	75 W at 12 V	
	Fan outer diameter	300 mm (11.81 in)	
Radiator fan (Main fan)	Motor type	Magnet	
	Power consumption	75 W at 12 V	
	Fan outer diameter	300 mm (11.81 in)	
Idling speed (A/C ON)	MPFI model	850±100 rpm	
Dual switch (Pressure switch)	Low-pressure switch operating pressure	ON → OFF	177±25 kPa (1.80±0.25 kg/cm ² , 25.6±3.6 psi)
		OFF → ON	216 ^{+39/-25} kPa (2.2 ^{+0.4/-0.25} kg/cm ² , 31 ^{+5.7/-3.6} psi)
	High-pressure switch operating pressure	ON → OFF	2,942±196 kPa (30±2 kg/cm ² , 427±28 psi)
		DIFF	588±196 kPa (6±2 kg/cm ² , 85±28 psi)
Thermo control amplifier working temperature (Evaporator outlet air)	<p style="text-align: center;"> OFF ————— 1.5±0.5°C (35±0.9°F) ————— ON Diff. 3.0±0.3°C (37±0.5°F) </p>		

B4M2237A

GENERAL DESCRIPTION

HVAC System (Heater, Ventilator and A/C)

3. A/C SYSTEM (6 CYLINDER) S701001E4904

Item		Specifications	
Type of air conditioner		Reheat air-mix type	
Cooling capacity		5.2 kW (4,471 kcal/h, 17,741 BTU/h)	
Refrigerant		HFC-134a (CH ₂ FCF ₃) [0.65±0.05 kg (1.43±0.11 lb)]	
Compressor	Type	5-vane rotary, fix volume (DKV-14G)	
	Discharge	140 cm ³ (8.54 cu in)/rev	
	Max. permissible speed	7,000 rpm	
Magnet clutch	Type	Dry, single-disc type	
	Power consumption	38 W	
	Type of belt	V-Ribbed 6 PK	
	Pulley dia. (effective dia.)	125 mm (4.92 in)	
	Pulley ratio	1.064	
Condenser	Type	Corrugated fin (Multi-flow)	
	Core face area	0.22 m ² (2.37 sq ft)	
	Core thickness	24 mm (0.94 in)	
	Radiation area	6.52 m ² (70 sq ft)	
Receiver drier	Effective inner capacity	250 cm ³ (15.26 cu in)	
Expansion valve	Type	Internal equalizing	
Evaporator	Type	Single tank	
	Dimensions (W × H × T)	235 × 224 × 60 mm (9.25 × 8.82 × 2.36 in)	
Blower fan	Fan type	Sirocco fan	
	Outer diameter × width	150 × 75 mm (5.91 × 2.95 in)	
	Power consumption	220 W at 12 V	
Condenser fan (Sub fan)	Motor type	Magnet	
	Power consumption	120 W at 12 V	
	Fan outer diameter	320 mm (12.60 in)	
Radiator fan (Main fan)	Motor type	Magnet	
	Power consumption	120 W at 12 V	
	Fan outer diameter	320 mm (12.60 in)	
Idling speed (A/C ON)	MPFI model	850±100 rpm	
Dual switch (Pressure switch)	Low-pressure switch operating pressure	ON → OFF	177±25 kPa (1.80±0.25 kg/cm ² , 25.6±3.6 psi)
		OFF → ON	216 ⁺³⁹ / ₋₂₅ kPa (2.2 ^{+0.4} / _{-0.25} kg/cm ² , 31 ^{+5.7} / _{-3.6} psi)
	High-pressure switch operating pressure	ON → OFF	2,942±196 kPa (30±2 kg/cm ² , 427±28 psi)
		DIFF	588±196 kPa (6±2 kg/cm ² , 85±28 psi)
Thermo control amplifier working temperature (Evaporator outlet air)	<p style="text-align: center;"> OFF ————— 1.5±0.5°C (35±0.9°F) ————— ON Diff. 3.0±0.3°C (37±0.5°F) </p>		

B4M2237A

GENERAL DESCRIPTION

HVAC System (Heater, Ventilator and A/C)

B: COMPONENT S701001A05

1. HEATER UNIT S701001A0501

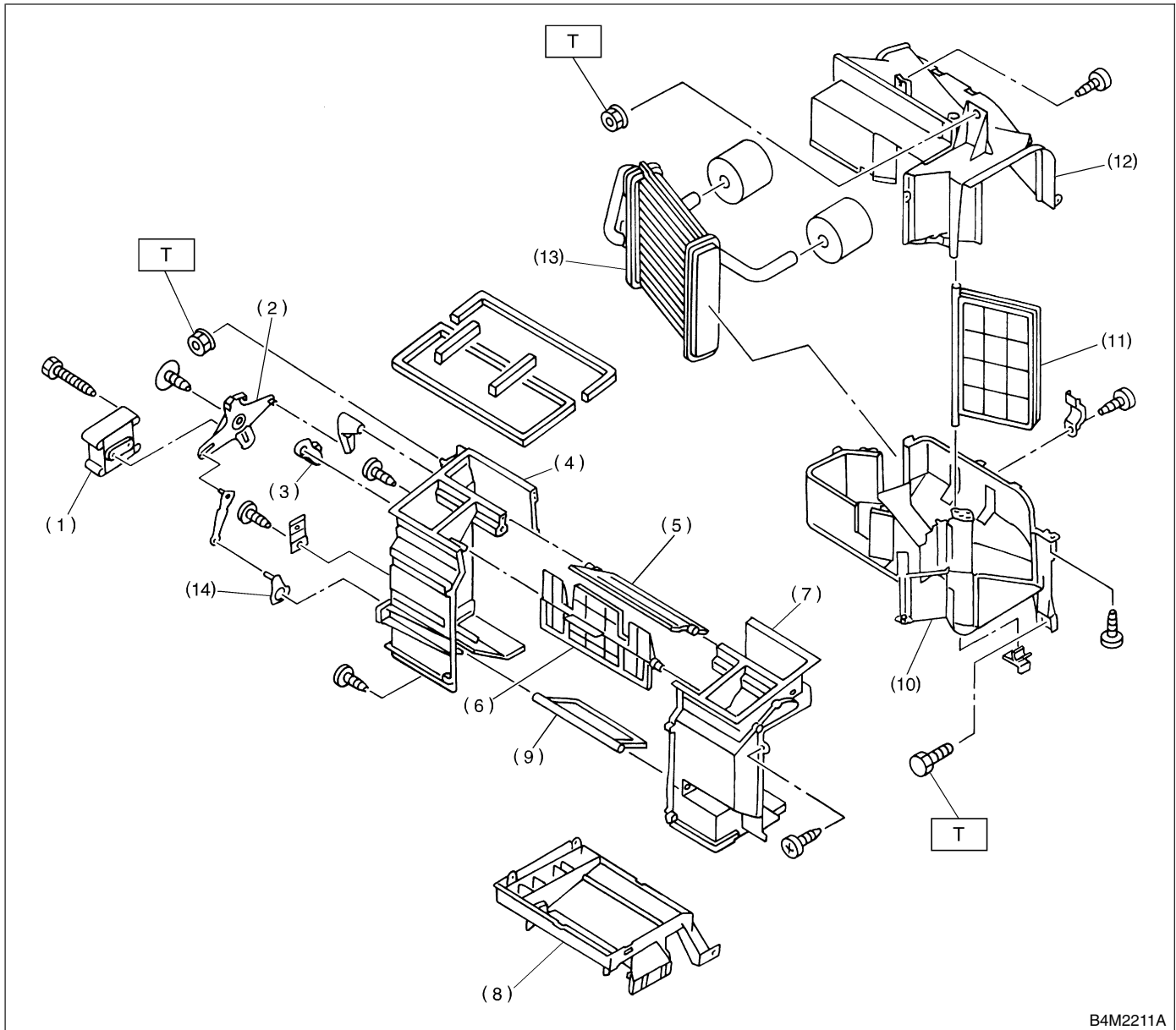

- (1) Vent door actuator
- (2) Side link
- (3) Vent door lever
- (4) Case A
- (5) DEF door
- (6) Vent door

- (7) Case B
- (8) Foot duct
- (9) Foot door
- (10) Case D
- (11) Mix door
- (12) Case C

- (13) Heater core
- (14) Foot door lever

Tightening torque: N-m (kgf-m, ft-lb)
T: 7.35 (0.750, 5.421)

GENERAL DESCRIPTION

HVAC System (Heater, Ventilator and A/C)

2. INTAKE UNIT S701001A0502

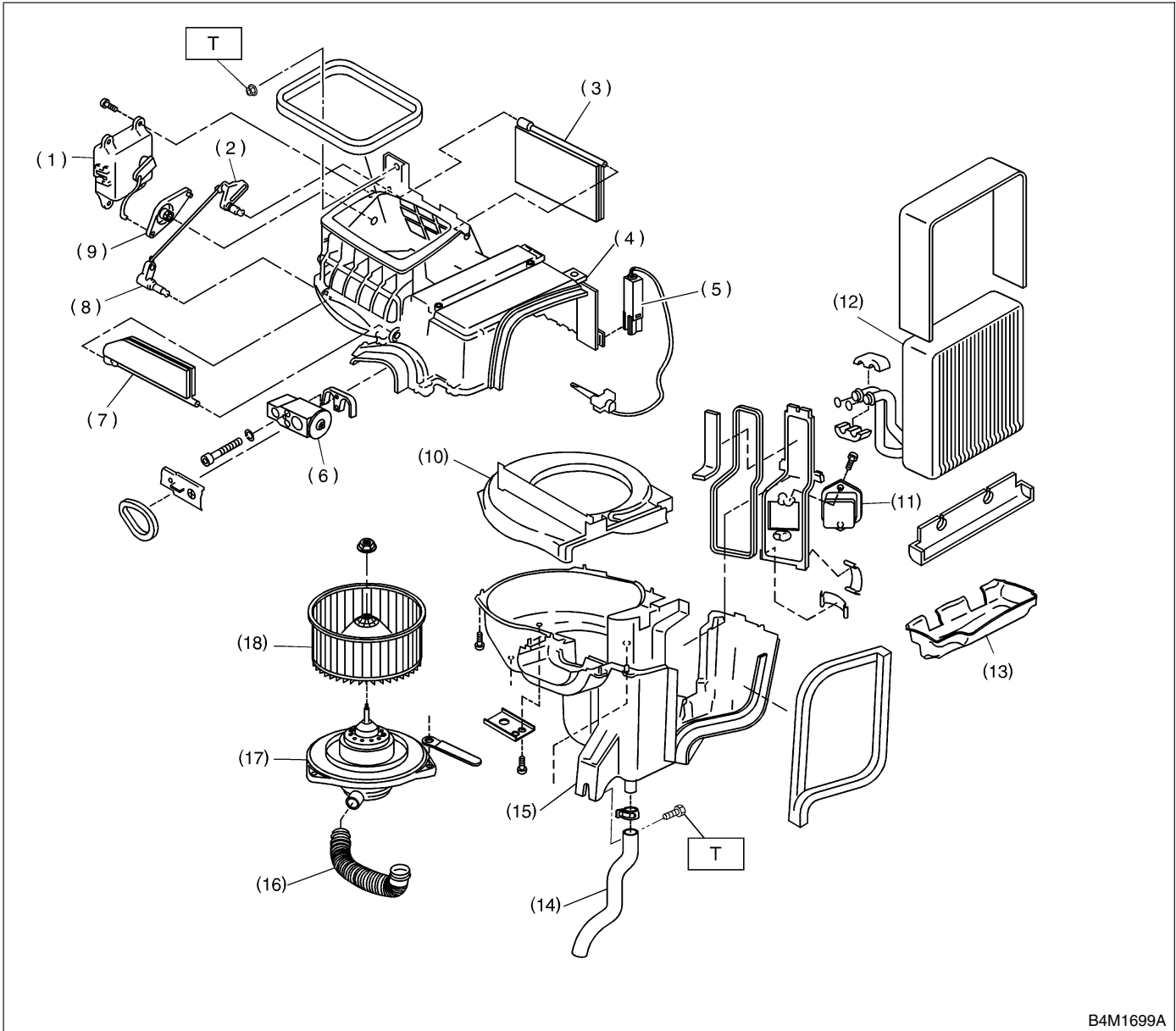

B4M1699A

- | | | |
|--|---------------------------------------|-----------------------------|
| (1) Intake door actuator | (8) Lever (B) | (15) Intake unit case lower |
| (2) Lever (A) | (9) Lever (C) | (16) Aspirator pipe |
| (3) Door (A) | (10) Blower plate | (17) Blower motor |
| (4) Intake unit case upper | (11) Resistor | (18) Fan |
| (5) Thermistor (With A/C model) | (12) Evaporator (With A/C model) | |
| (6) Block expansion valve (With A/C model) | (13) Evaporator case (With A/C model) | |
| (7) Door (B) | (14) Drain hose | |

Tightening torque: N·m (kgf·m, ft·lb)

T: 7.4 (0.75, 5.4)

GENERAL DESCRIPTION

HVAC System (Heater, Ventilator and A/C)

3. CONTROL UNIT (MANUAL A/C) S701001A0507

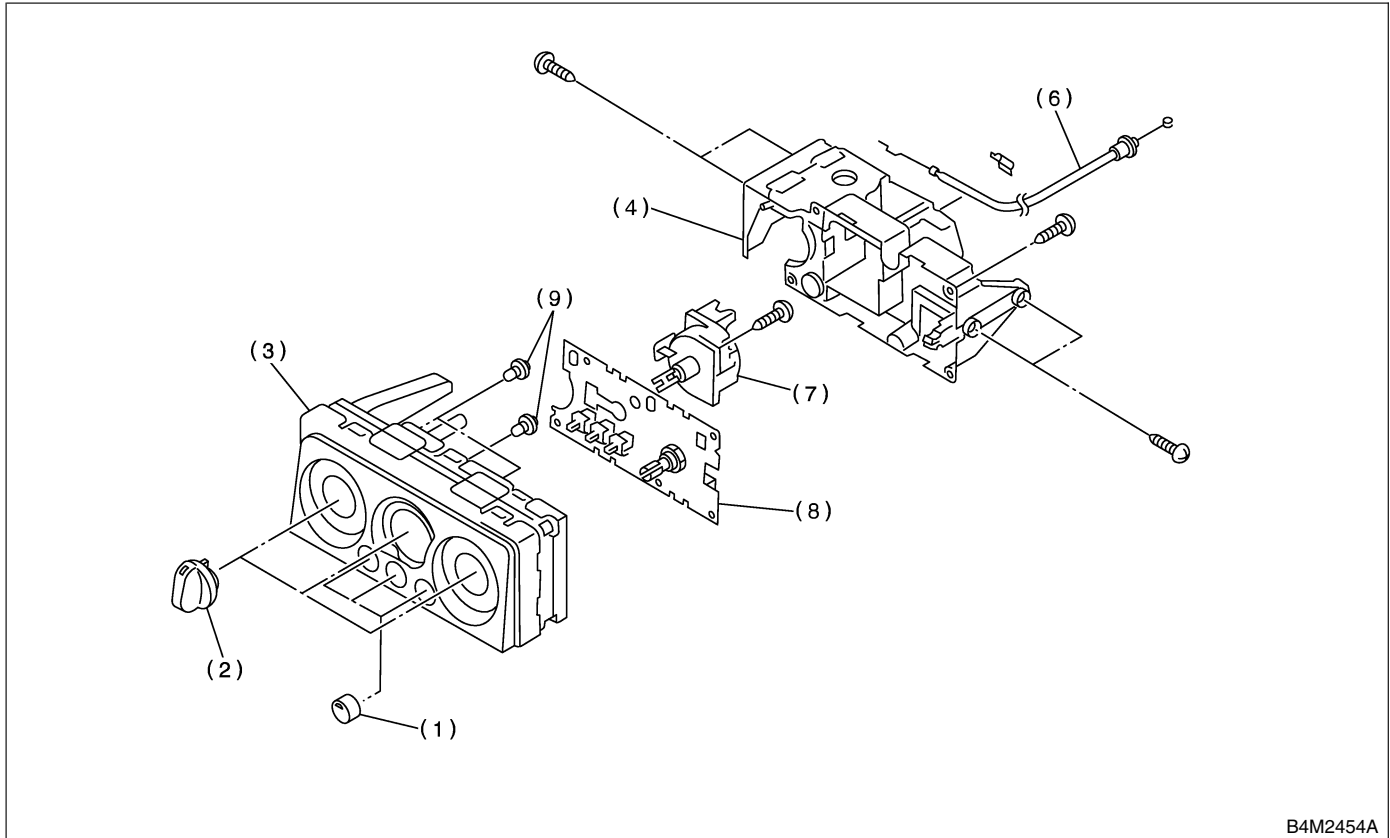

B4M2454A

- | | | |
|------------------------|-------------------------------|---------------------|
| (1) Switch | (4) Base unit | (7) Fan switch ASSY |
| (2) Control dial knob | (5) Cover | (8) Circuit ASSY |
| (3) Control panel ASSY | (6) Temperature control cable | (9) Bulb |

GENERAL DESCRIPTION

HVAC System (Heater, Ventilator and A/C)

4. CONTROL UNIT (AUTO A/C) S701001A0508

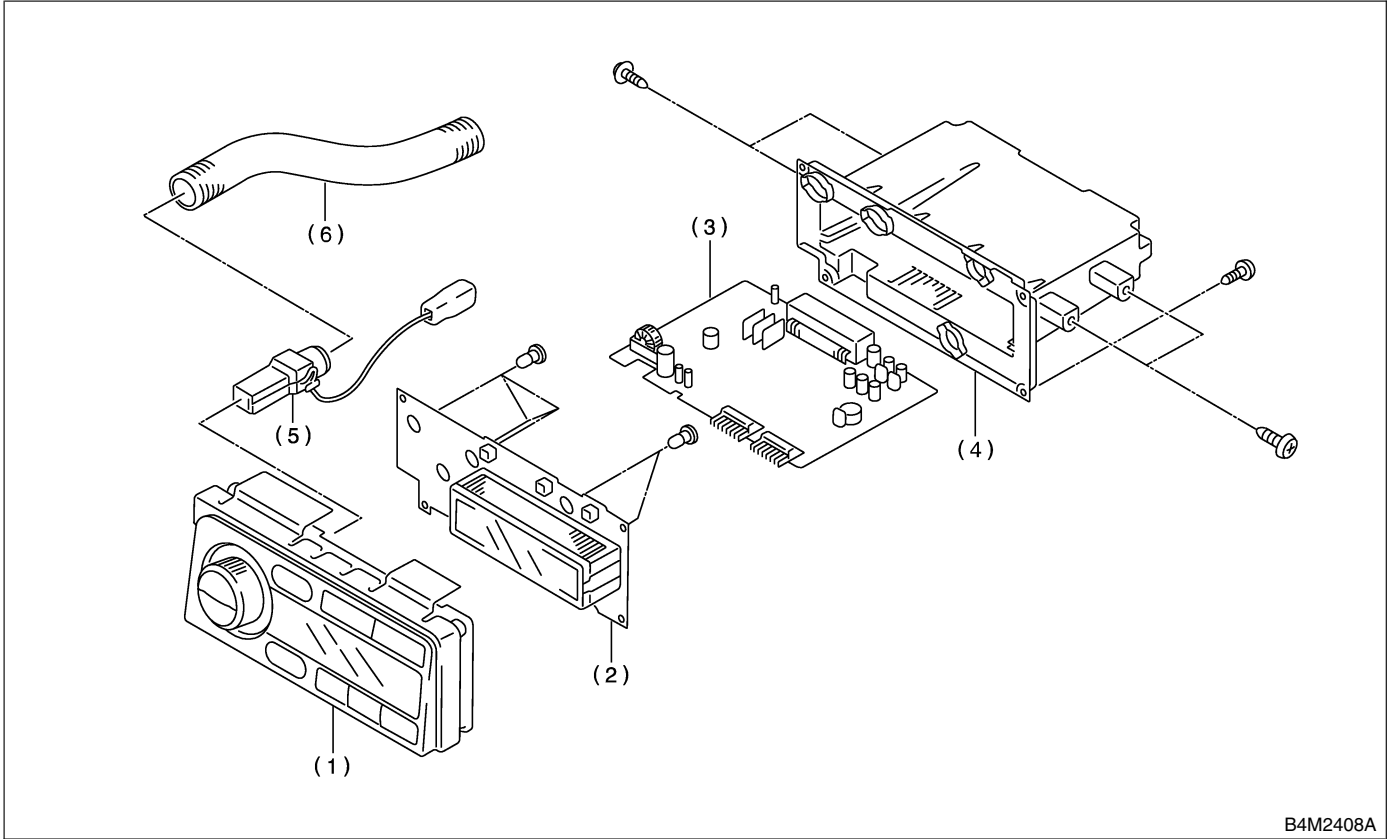

(1) Control panel
(2) Circuit ASSY

(3) Electronic control unit
(4) Control case

(5) In-car sensor
(6) Aspirator hose

GENERAL DESCRIPTION

HVAC System (Heater, Ventilator and A/C)

5. AIR CONDITIONING UNIT S701001A0504

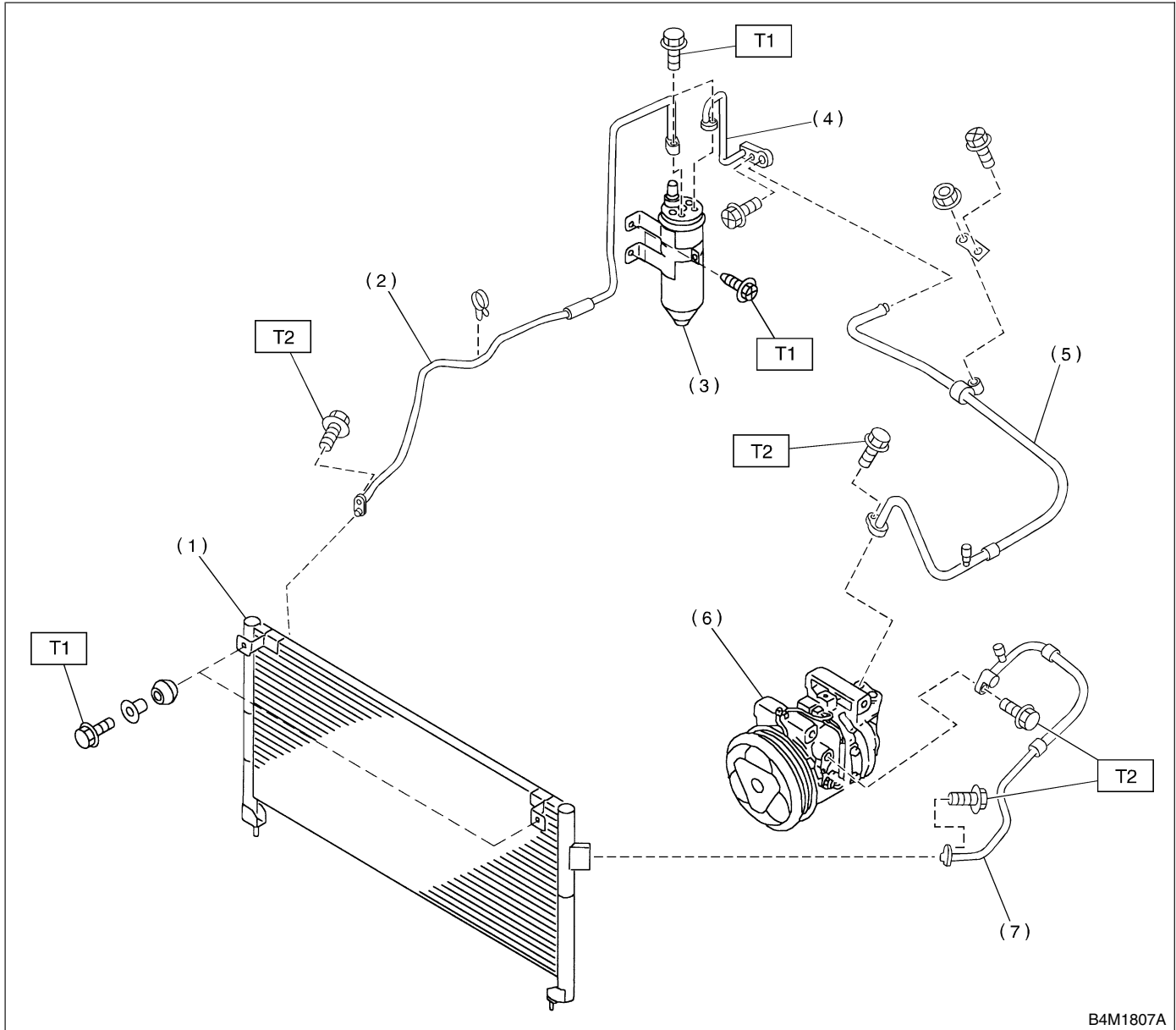

- | | |
|---------------------------------------|--------------------------|
| (1) Condenser | (5) Hose (Low-pressure) |
| (2) Pipe (Condenser — Receiver drier) | (6) Compressor |
| (3) Receiver drier | (7) Hose (High-pressure) |
| (4) Pipe (Receiver drier — C/unit) | |

Tightening torque: N·m (kgf·m, ft·lb)

T1: 7.4 (0.75, 5.4)

T2: 15 (1.5, 10.8)

GENERAL DESCRIPTION

HVAC System (Heater, Ventilator and A/C)

6. INTAKE UNIT WITH EVAPORATOR

S701001A0505

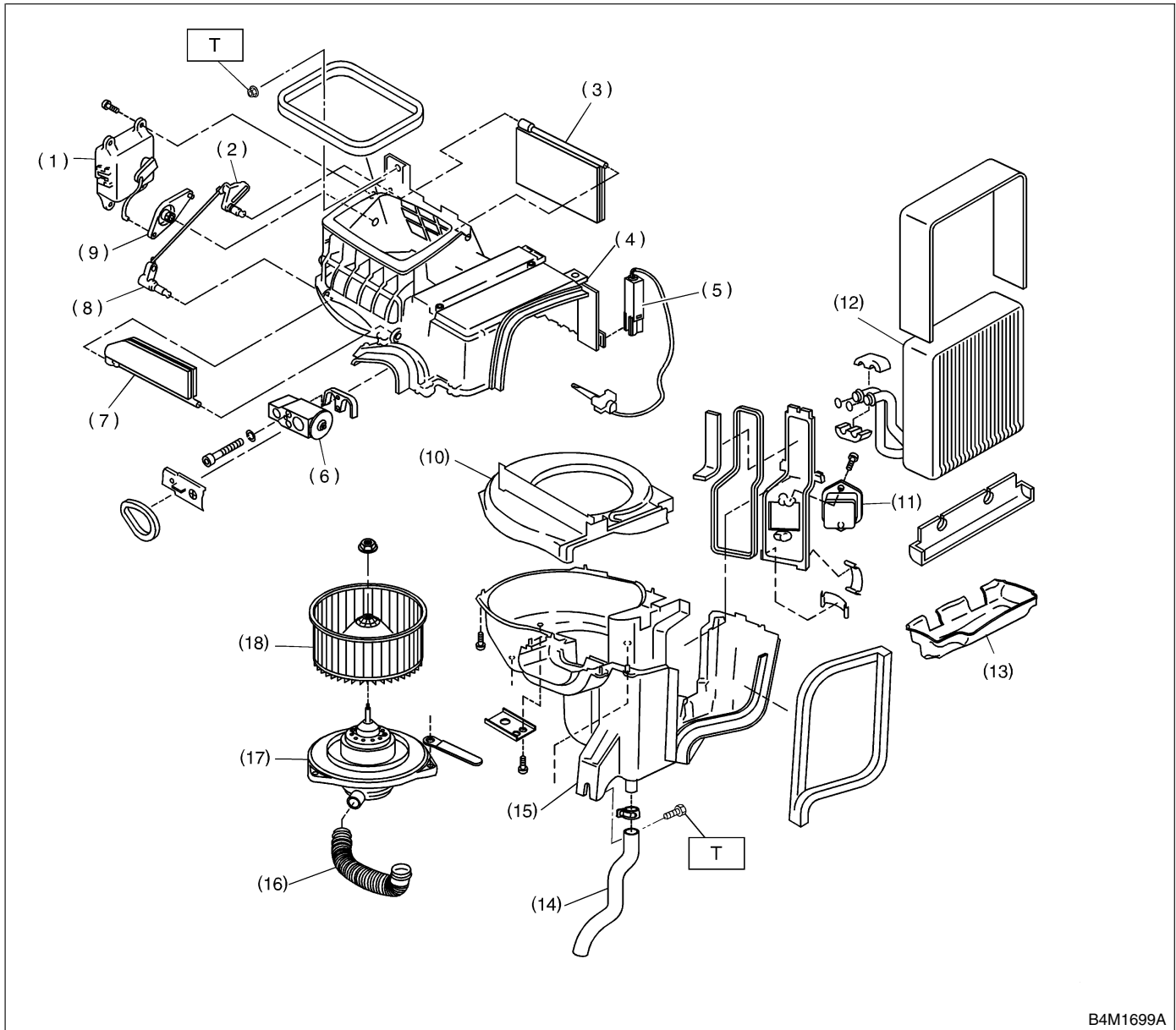

B4M1699A

- | | | |
|--|---------------------------------------|-----------------------------|
| (1) Intake door actuator | (8) Lever (B) | (15) Intake unit case lower |
| (2) Lever (A) | (9) Lever (C) | (16) Aspirator pipe |
| (3) Door (A) | (10) Blower plate | (17) Blower motor |
| (4) Intake unit case upper | (11) Resistor | (18) Fan |
| (5) Thermistor (With A/C model) | (12) Evaporator (With A/C model) | |
| (6) Block expansion valve (With A/C model) | (13) Evaporator case (With A/C model) | |
| (7) Door (B) | (14) Drain hose | |

Tightening torque: N·m (kgf·m, ft·lb)
T: 7.35 (0.750, 5.421)

GENERAL DESCRIPTION

HVAC System (Heater, Ventilator and A/C)

7. COMPRESSOR S701001A0506

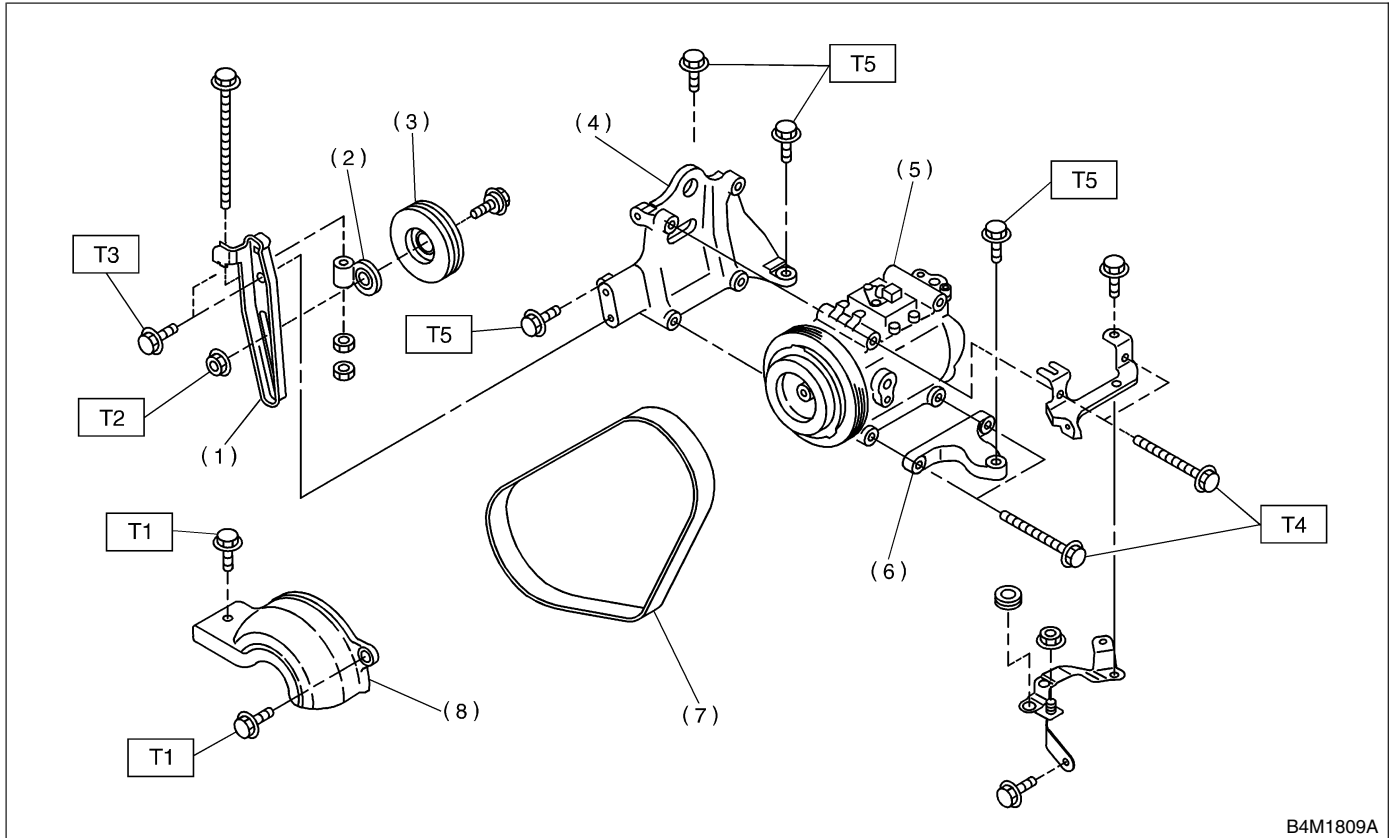

B4M1809A

- (1) Idler pulley bracket
- (2) Idler pulley adjuster
- (3) Idler pulley
- (4) Compressor bracket upper
- (5) Compressor
- (6) Compressor bracket lower
- (7) V-belt
- (8) Compressor belt cover

Tightening torque: N-m (kgf-m, ft-lb)

T1: 7.4 (0.75, 5.4)

T2: 23 (2.3, 17)

T3: 23.0 (2.35, 17.0)

T4: 28.9 (2.95, 21.3)

T5: 35 (3.6, 26)

GENERAL DESCRIPTION

HVAC System (Heater, Ventilator and A/C)

C: CAUTION S701001A03

1. HFC-134a A/C SYSTEM S701001A0301

- Unlike the old conventional HFC-12 system components, the cooling system components for the HFC-134a system such as the refrigerant and compressor oil are incompatible.
- Vehicles with the HFC-134a system can be identified by the label “A” attached to the vehicle. Before maintenance, check which A/C system is installed in the vehicle.

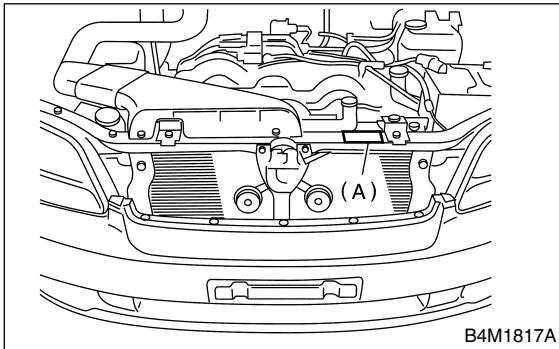

2. COMPRESSOR OIL S701001A0302

- HFC-134a compressor oil has no compatibility with that for R12 system.
- Use only the manufacturer-authorized compressor oil for the HFC-134a system; only use ZXL200PG.
- Do not mix multiple compressor oils. If HFC-12 compressor oil is used in a HFC-134a A/C system, the compressor may become stuck due to poor lubrication, or the refrigerant may leak due to swelling of rubber parts. On the other hand, if HFC-134a compressor oil is used in a HFC-12 A/C system, the durability of the A/C system will be lowered.
- HFC-134a compressor oil is very hygroscopic. When replacing or installing/removing A/C parts, immediately isolate the oil from the atmosphere using a plug or tape. In order to avoid moisture, store the oil in a container with its cap tightly closed.

3. REFRIGERANT S701001A0303

- The HFC-12 refrigerant cannot be used in the HFC-134a A/C system. The HFC-134a refrigerant, also, cannot be used in the HFC-12 A/C system.
- If an incorrect or no refrigerant is used, poor lubrication will result and the compressor itself may be damaged.

4. HANDLING OF REFRIGERANT S701001A0304

- The refrigerant boils at approx. -30°C (-22°F). When handling it, be sure to wear safety goggles and protective gloves. Direct contact of the refrigerant with skin may cause frostbite. If the refrigerant gets into your eye, avoid rubbing your eyes with your hands. Wash your eye with plenty of water, and receive medical treatment from an eye doctor.
- Do not heat a service can. If a service can is directly heated, or put into boiling water, the inside pressure will become extremely high. This may cause the can to explode. If a service can must be warmed up, use hot water in 40°C (104°F) max.
- Do not drop or impact a service can. (Observe the precautions and operation procedure described on the refrigerant can.)
- When the engine is running, do not open the high-pressure valve of the manifold gauge. The high-pressure gas will back-flow resulting in an explosion of the can.
- The refrigerant is non-toxic and harmless under normal operating circumstance, but it may change to phosgene (a noxious fume) under open flames or high temperatures (caused by a cigarette or heater).
- Provide good ventilation and do not work in a closed area.
- Never perform a gas leak test using a halide torch-type leak tester.
- In order to avoid destroying the ozone layer, prevent HFC-134a from being released into the atmosphere. Using a refrigerant recovery system, discharge and reuse it.

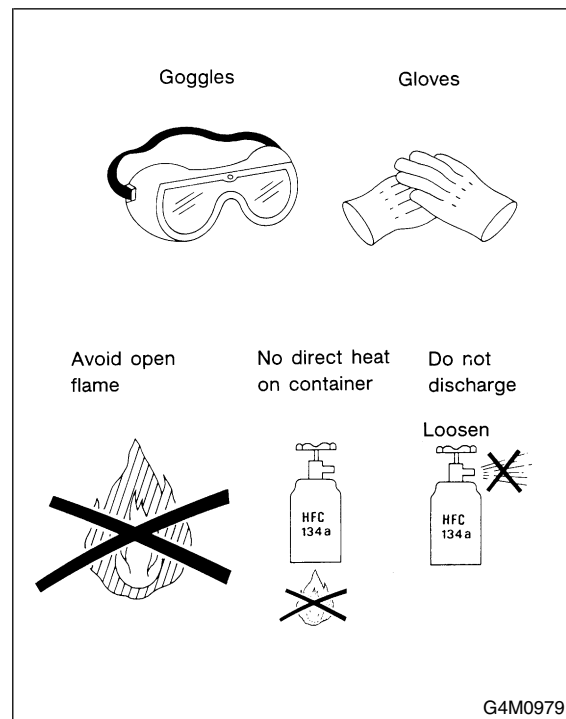

GENERAL DESCRIPTION

HVAC System (Heater, Ventilator and A/C)

5. O-RING CONNECTIONS S701001A0305

- Use new O-rings.
- In order to keep the O-rings free of lint which will cause a refrigerant gas leak, perform operations without gloves and shop towels.
- Apply the compressor oil to the O-rings to avoid sticking, then install them.
- Use a torque wrench to tighten the O-ring fittings: Over-tightening will damage the O-ring and tube end distortion.
- If the operation is interrupted before completing a pipe connection, recap the tubes, components, and fittings with a plug or tape to prevent contamination from entering.

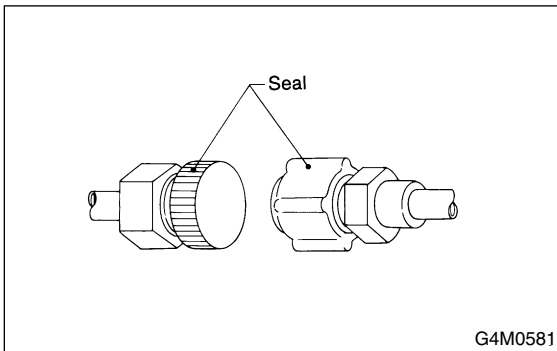

- Visually check the surfaces and mating surfaces of O-rings, threads, and connecting points. If a failure is found, replace the applicable parts.
- Install the O-rings at right angle to the tube beads.

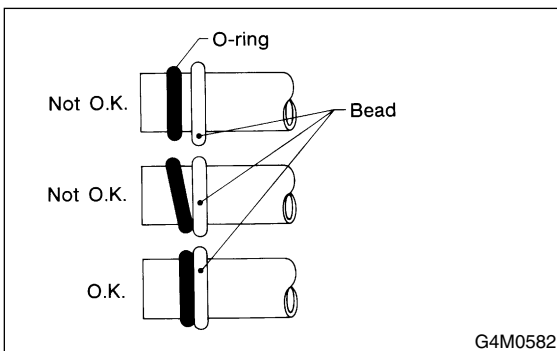

- Use the oil specified in the service manual to lubricate the O-rings. Apply the oil to the top and sides of the O-rings before installation. Apply the oil to the area including the O-rings and tube beads.

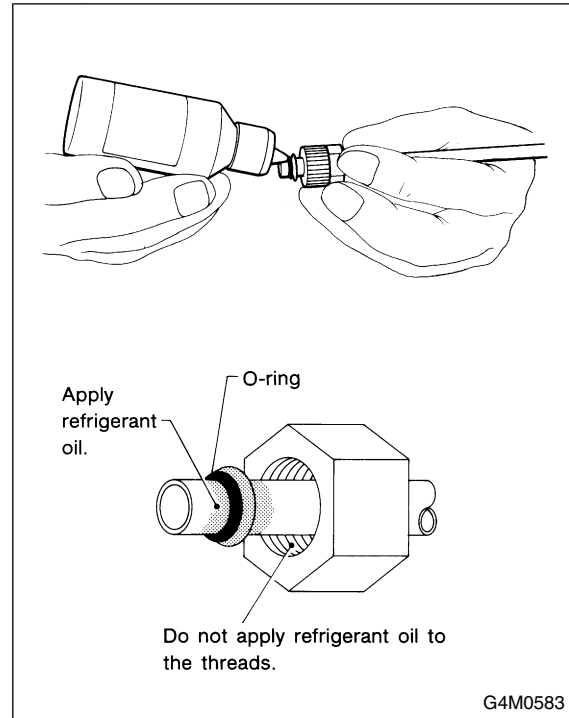

- When connecting hoses or pipes, use 2 wrenches (a torque wrench for tightening). While securing one side with a wrench, tighten the other side to the specified torque with a torque wrench. If only one wrench is used to tighten, the tightening torque will be excessive or insufficient. This may cause a pipe distortion or gas leak, resulting in damage to hoses and pipes.
- After tightening, using a clean shop towel to remove excess oil from the connections and any oil which may have run on the vehicle body or other parts.
- If any leakage is suspected after tightening, do not retighten the connections, Disconnect the connections, remove the O-rings, and check the O-rings, threads, and connections.

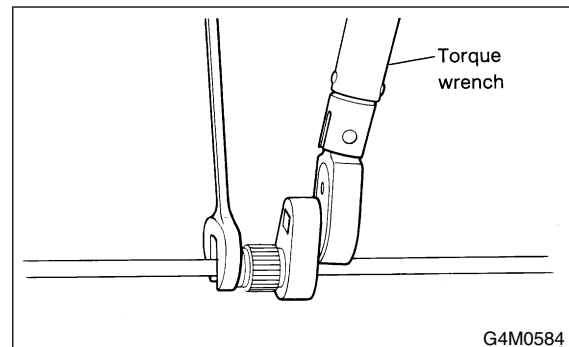

GENERAL DESCRIPTION

HVAC System (Heater, Ventilator and A/C)

D: PREPARATION TOOL S701001A17

CAUTION:

When working on vehicles with the HFC-134a system, only use HFC-134a specified tools and parts. Do not mix with CFC-12 tools and parts. If HFC-134a and CFC-12 refrigerant or compressor oil is mixed, poor lubrication will result and the compressor itself may be destroyed. In order to help prevent mixing HFC-134a and CFC-12 parts and liquid, the tool and screw type and the type of service valves used are different. The gas leak detectors for the HFC-134a and CFC-12 systems must also not be interchanged.

	HFC-134a	CFC-12
Tool & screw type	Millimeter size	Inch size
Valve type	Quick joint type	Screw-in type

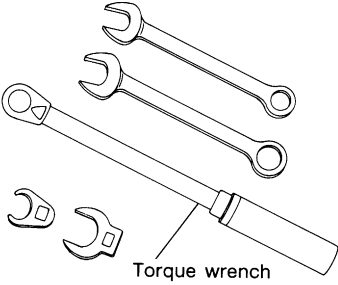
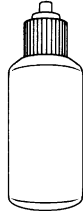
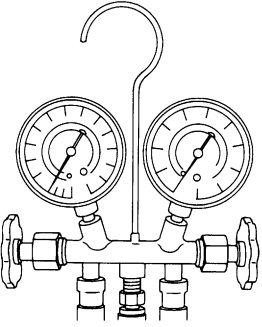
Tools and Equipment	Description
<p>Wrench</p> <p>Various WRENCHES will be required to service any A/C system. A 7 to 40 N-m (0.7 to 4.1 kg-m, 5 to 30 ft-lb) torque wrench with various crowfoot wrenches will be needed. Open end or flare nut wrenches will be needed for back-up on the tube and hose fittings.</p>	 <p style="text-align: center;">Torque wrench</p> <p style="text-align: right;">G4M0571</p>
<p>Applicator bottle</p> <p>A small APPLICATOR BOTTLE is recommended to apply refrigerant oil to the various parts. They can be obtained at a hardware or drug store.</p>	 <p style="text-align: right;">G4M0572</p>
<p>Manifold gauge set</p> <p>A MANIFOLD GAUGE SET (with hoses) can be obtained from either a commercial refrigeration supply house or from an auto shop equipment supplier.</p>	 <p style="text-align: right;">G4M0573</p>

GENERAL DESCRIPTION

HVAC System (Heater, Ventilator and A/C)

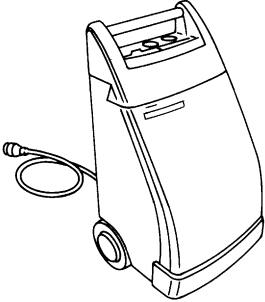
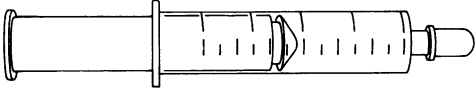
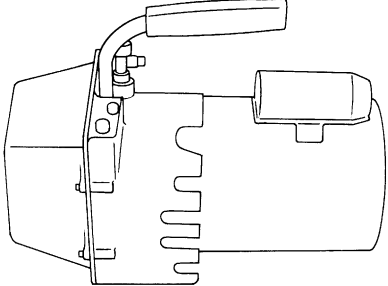
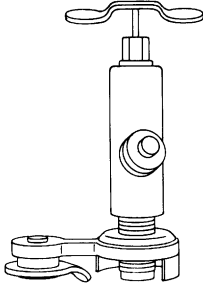
Tools and Equipment	Description
<p>Refrigerant recovery system</p> <p>A REFRIGERANT RECOVERY SYSTEM is used for the recovery and reuse of A/C system refrigerant after contaminants and moisture have been removed from the refrigerant.</p>	 <p>G4M0574</p>
<p>Syringe</p> <p>A graduated plastic SYRINGE will be needed to add oil back into the system. The syringe can be found at a pharmacy or drug store.</p>	 <p>G4M0575</p>
<p>Vacuum pump</p> <p>A VACUUM PUMP (in good working condition) is necessary, and may be obtained from either a commercial refrigeration supply house or an automotive equipment supplier.</p>	 <p>G4M0576</p>
<p>Can tap</p> <p>A CAN TAP for the 397 g (14 oz) can is available from an auto supply store.</p>	 <p>G4M0577</p>

GENERAL DESCRIPTION

HVAC System (Heater, Ventilator and A/C)

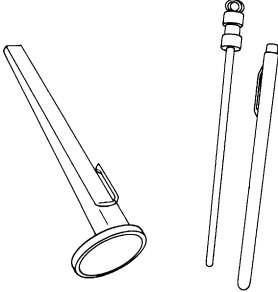
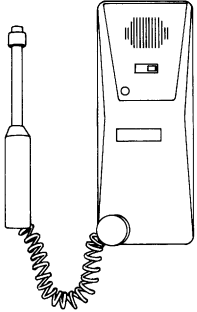
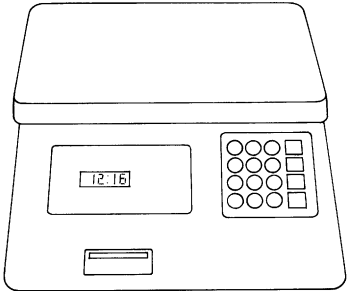
Tools and Equipment	Description
<p>Thermometer</p> <p>Pocket THERMOMETERS are available from either industrial hardware store or commercial refrigeration supply houses.</p>	 <p>G4M0578</p>
<p>Electronic leak detector</p> <p>An ELECTRONIC LEAK DETECTOR can be obtained from either a specialty tool supply or an A/C equipment supplier.</p>	 <p>G4M0579</p>
<p>Weight scale</p> <p>A WEIGHT SCALE such as an electronic charging scale or a bathroom scale with digital display will be needed if a 13.6 kg (30 lb) refrigerant container is used.</p>	 <p>G4M0580</p>

2. Refrigerant Pressure with Manifold Gauge Set S701631

A: OPERATION S701631A16

- 1) Place the vehicle in a shady draft-free location.
- 2) Connect the manifold gauge set.
- 3) Open the front windows and close all doors.
- 4) Open the hood.
- 5) Increase engine rpm to 1,500.
- 6) Turn ON the A/C switch.
- 7) Turn the temperature control switch to MAX COOL.
- 8) Put in RECIRC position.
- 9) Turn the blower control switch to HI.
- 10) Read the gauge.

Standard:

Low pressure: 127 - 196 kPa (1.3 - 2.0 kg/cm², 18 - 28 psi)

High pressure: 1,471 - 1,667 kPa (15 - 17 kg/cm², 213 - 242 psi)

Ambient temperature: 30 - 35°C (86 - 95°F)

B: INSPECTION S701631A10

Symptom	Probable cause	Repair order
High-pressure side is unusually high.	<ul style="list-style-type: none"> ● Defective condenser fan motor ● Clogged condenser fan ● Too much refrigerant ● Air inside the system ● Defective receiver drier 	<ul style="list-style-type: none"> ● Replace the fan motor. ● Clean the condenser fin. ● Discharge refrigerant. ● Replace the receiver drier.
High-pressure side is unusually low.	<ul style="list-style-type: none"> ● Defective compressor ● Not enough refrigerant ● Clogged expansion valve ● Expansion valve frozen temporarily by moisture 	<ul style="list-style-type: none"> ● Replace the compressor. ● Check for leaks. ● Replace the expansion valve.
Low-pressure side is unusually high.	<ul style="list-style-type: none"> ● Defective compressor ● Defective expansion valve ● Too much refrigerant 	<ul style="list-style-type: none"> ● Replace the compressor. ● Replace the expansion valve. ● Discharge refrigerant.
Low-pressure side is unusually low.	<ul style="list-style-type: none"> ● Not enough refrigerant ● Clogged expansion valve ● Expansion valve frozen temporarily by moisture ● Saturated receiver drier 	<ul style="list-style-type: none"> ● Check for leaks. ● Replace the expansion valve ● Replace the receiver drier.

2. Refrigerant Pressure with Manifold Gauge Set S701631

A: OPERATION S701631A16

- 1) Place the vehicle in a shady draft-free location.
- 2) Connect the manifold gauge set.
- 3) Open the front windows and close all doors.
- 4) Open the hood.
- 5) Increase engine rpm to 1,500.
- 6) Turn ON the A/C switch.
- 7) Turn the temperature control switch to MAX COOL.
- 8) Put in RECIRC position.
- 9) Turn the blower control switch to HI.
- 10) Read the gauge.

Standard:

Low pressure: 127 - 196 kPa (1.3 - 2.0 kg/cm², 18 - 28 psi)

High pressure: 1,471 - 1,667 kPa (15 - 17 kg/cm², 213 - 242 psi)

Ambient temperature: 30 - 35°C (86 - 95°F)

B: INSPECTION S701631A10

Symptom	Probable cause	Repair order
High-pressure side is unusually high.	<ul style="list-style-type: none"> ● Defective condenser fan motor ● Clogged condenser fan ● Too much refrigerant ● Air inside the system ● Defective receiver drier 	<ul style="list-style-type: none"> ● Replace the fan motor. ● Clean the condenser fin. ● Discharge refrigerant. ● Replace the receiver drier.
High-pressure side is unusually low.	<ul style="list-style-type: none"> ● Defective compressor ● Not enough refrigerant ● Clogged expansion valve ● Expansion valve frozen temporarily by moisture 	<ul style="list-style-type: none"> ● Replace the compressor. ● Check for leaks. ● Replace the expansion valve.
Low-pressure side is unusually high.	<ul style="list-style-type: none"> ● Defective compressor ● Defective expansion valve ● Too much refrigerant 	<ul style="list-style-type: none"> ● Replace the compressor. ● Replace the expansion valve. ● Discharge refrigerant.
Low-pressure side is unusually low.	<ul style="list-style-type: none"> ● Not enough refrigerant ● Clogged expansion valve ● Expansion valve frozen temporarily by moisture ● Saturated receiver drier 	<ul style="list-style-type: none"> ● Check for leaks. ● Replace the expansion valve ● Replace the receiver drier.

REFRIGERANT RECOVERY PROCEDURE

HVAC System (Heater, Ventilator and A/C)

3. Refrigerant Recovery Procedure S701291

A: OPERATION S701291A16

CAUTION:

- During operation, be sure to wear safety goggles and protective gloves.
- Connect the refrigerant recovery system with the manifold gauge set to discharge the refrigerant from the A/C system and reuse it.
- When reusing the discharged refrigerant, keep service cans on hand. Because the discharge rate with the recovery system is approx. 90%, service cans are necessary to charge the refrigerant.
- Follow the detailed operation procedure described in the operation manual attached to the refrigerant recovery system.

- 1) Perform the compressor oil return operation.
<Ref. to AC-24, OPERATION, Compressor Oil.>
- 2) Stop the engine.
- 3) Close the valves on the low-/high-pressure sides of the manifold gauge set.

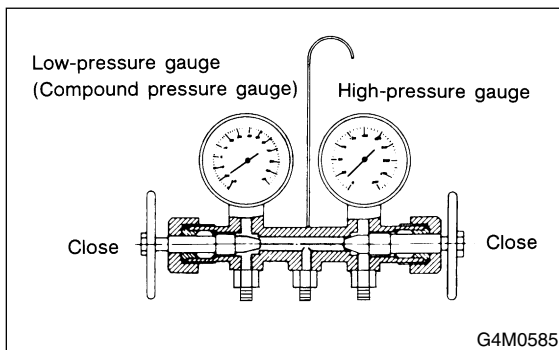

- 4) Install the low-/high-pressure hoses to the service ports on the low-/high-pressure sides of the vehicle respectively.

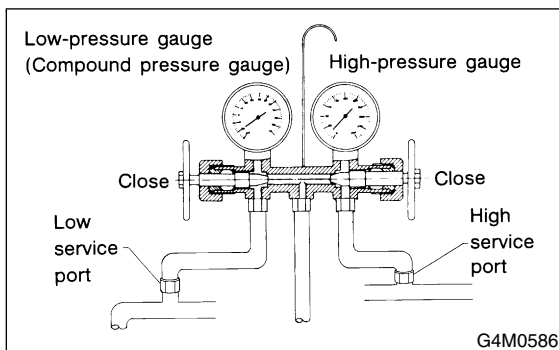

- 5) Connect the center hose to the refrigerant recovery system.
- 6) Follow the operation manual to activate the refrigerant recovery system.

REFRIGERANT RECOVERY PROCEDURE

HVAC System (Heater, Ventilator and A/C)

3. Refrigerant Recovery Procedure

S701291

A: OPERATION

S701291A16

CAUTION:

- During operation, be sure to wear safety goggles and protective gloves.
- Connect the refrigerant recovery system with the manifold gauge set to discharge the refrigerant from the A/C system and reuse it.
- When reusing the discharged refrigerant, keep service cans on hand. Because the discharge rate with the recovery system is approx. 90%, service cans are necessary to charge the refrigerant.
- Follow the detailed operation procedure described in the operation manual attached to the refrigerant recovery system.

- 1) Perform the compressor oil return operation.
<Ref. to AC-24, OPERATION, Compressor Oil.>
- 2) Stop the engine.
- 3) Close the valves on the low-/high-pressure sides of the manifold gauge set.

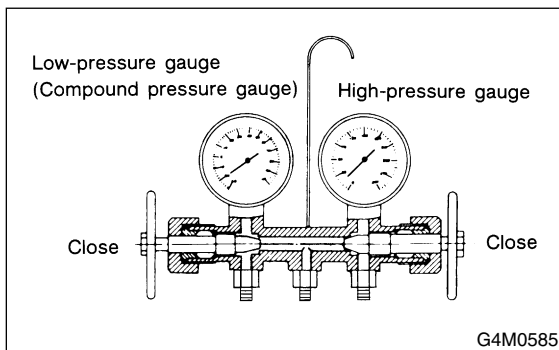

- 4) Install the low-/high-pressure hoses to the service ports on the low-/high-pressure sides of the vehicle respectively.

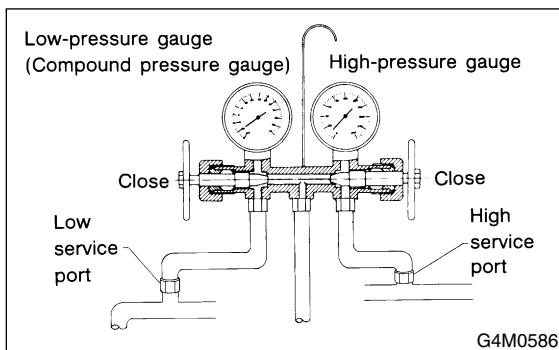

- 5) Connect the center hose to the refrigerant recovery system.
- 6) Follow the operation manual to activate the refrigerant recovery system.

REFRIGERANT CHARGING PROCEDURE

HVAC System (Heater, Ventilator and A/C)

4. Refrigerant Charging Procedure

S701292

A: OPERATION

S701292A16

CAUTION:

- During operation, be sure to wear safety goggles and protective gloves.
- Before charging the refrigerant, evacuate the system to remove small amounts of moisture remaining in the system. The moisture in the system can be completely evacuated only under the minimum vacuum level. The minimum vacuum level affects the temperature in the system.
- The list below shows the vacuum values necessary to boil water in various temperature. In addition, the vacuum levels indicated on the gauge are approx. 3.3 kPa (25 mmHg, 0.98 inHg) lower than those measured at 304.8 m (1,000 ft) above sea level.

Vacuum level required to boil water (at sea level)	
Temperature	Vacuum
1.7°C (35°F)	100.9 kPa (757 mmHg, 29.8 inHg)
7.2°C (45°F)	100.5 kPa (754 mmHg, 29.7 inHg)
12.8°C (55°F)	99.8 kPa (749 mmHg, 29.5 inHg)
18.3°C (65°F)	99.2 kPa (744 mmHg, 29.3 inHg)
23.9°C (75°F)	98.5 kPa (739 mmHg, 29.1 inHg)
29.4°C (85°F)	97.2 kPa (729 mmHg, 28.7 inHg)
35°C (95°F)	95.8 kPa (719 mmHg, 28.3 inHg)

1) Close the valves on low-/high-pressure sides of the manifold gauge.

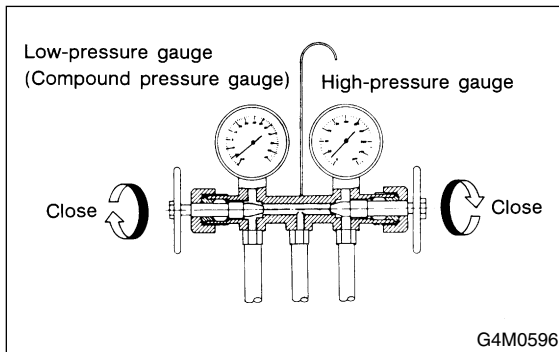

- 2) Install the low-/high-pressure hoses to the corresponding service ports on the vehicle respectively.
- 3) Connect the center hose of the manifold gauge set with the vacuum pump.

4) Carefully open the valves on the low-/high-pressure sides to activate the vacuum pump.

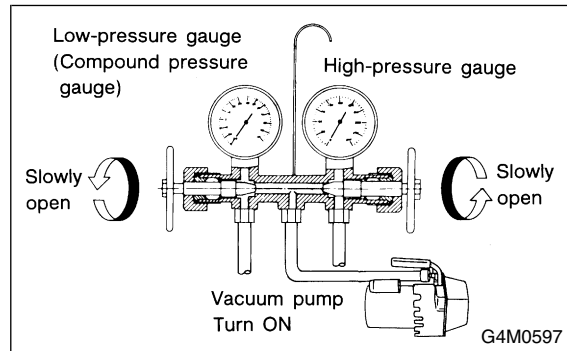

5) After the low-pressure gauge reaches 100.0 kPa (750 mmHg, 29.5 inHg) or higher, evacuate the system for approx. 15 minutes.

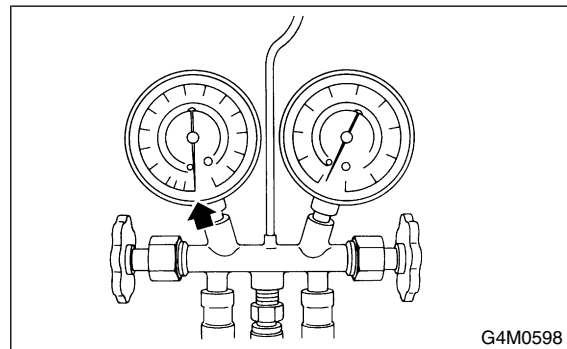

6) After 15 minutes of evacuation, if the reading shows 100.0 kPa (750 mmHg, 29.5 inHg) or higher, close the valves on the both sides to stop the vacuum pump.

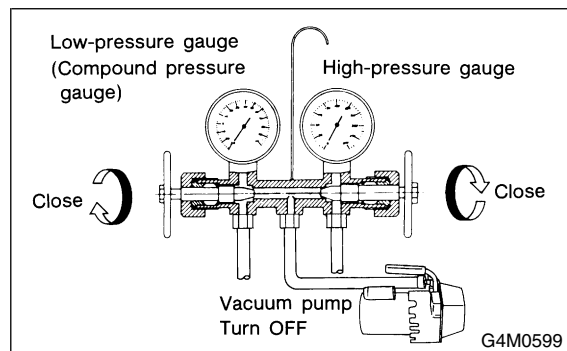

7) Note the low-pressure gauge reading.

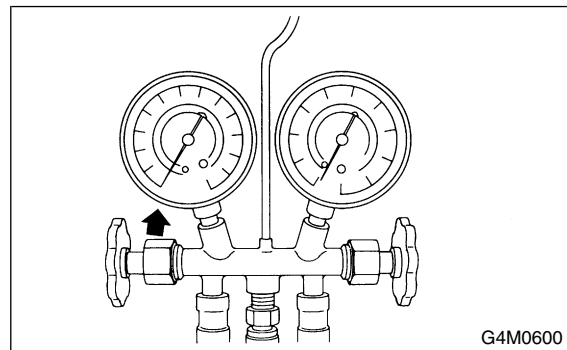

REFRIGERANT CHARGING PROCEDURE

HVAC System (Heater, Ventilator and A/C)

- 8) Leave it at least 5 minutes, and then check the low-pressure gauge reading for any changes. When a gauge indicator shows near to zero point, this is a sign of leakage. Check pipe connector points, repair them, make sure there is no leakage by air bleeding.
- 9) Following the can tap operation manual instructions, install it to the refrigerant can.

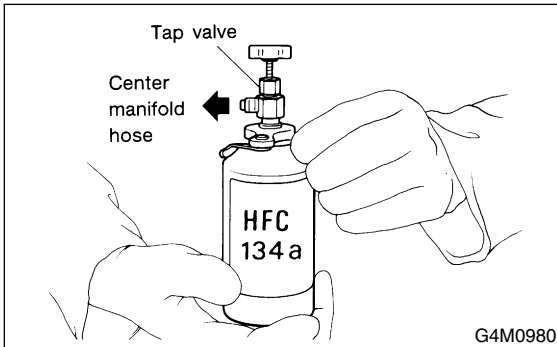

- 10) Disconnect the center manifold hose from the vacuum pump, and connect the hose to the tap valve.

- 11) When a 13.6 kg (30 lb) refrigerant container is used, measure the refrigerant amount in use using a weighting scale.

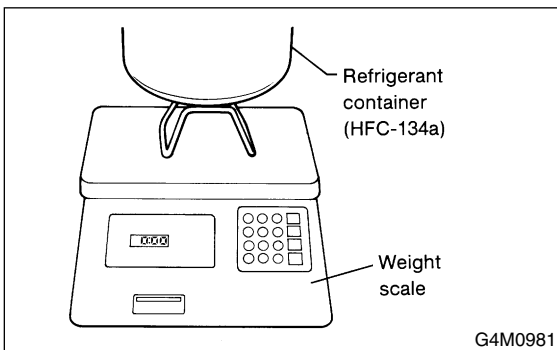

- 12) Confirm that all the 3 hoses are tightly connected to the manifold gauge set.

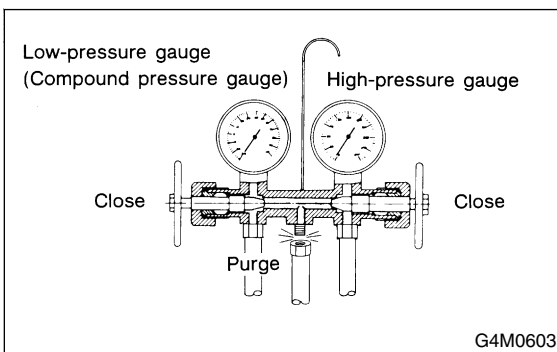

- 13) Open the valve on the HFC-134a source.
- 14) Loosen the center hose connection on the manifold gauge set (if applicable, press a purge valve on the manifold gauge set) only for a couple of seconds to allow the air in the center hose to escape by the refrigerant.

- 15) Carefully open the high-pressure valve with the engine OFF.

CAUTION:
Do not open the low-pressure valve.

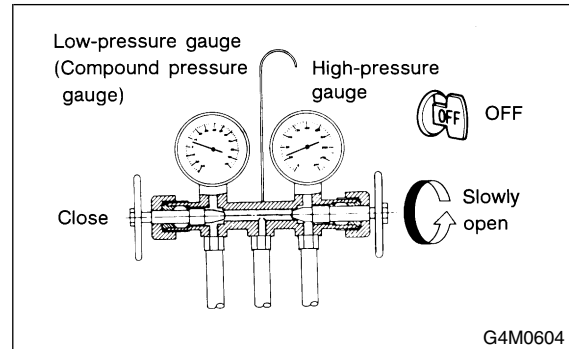

CAUTION:
Never run the engine during charging from the high-pressure side.

- 16) Close the high-pressure valve when the low-pressure gauge reaches 98 kPa (1 kg/cm², 14 psi). Using a leak tester, check the system for leaks. If any leakage is found after the refrigerant recovery is completed, repair the applicable area.

- 17) After confirming that there are no leaks with the leak test, charge the required amount of refrigerant.

CAUTION:
Never run the engine during charging from the high-pressure side.

- 18) Close the high-pressure valve when;
- the readings of low- and high-pressure gauges become almost equal, after the charging speed is reduced,
 - the HFC-134a source becomes empty, or
 - the system is filled with the gas.

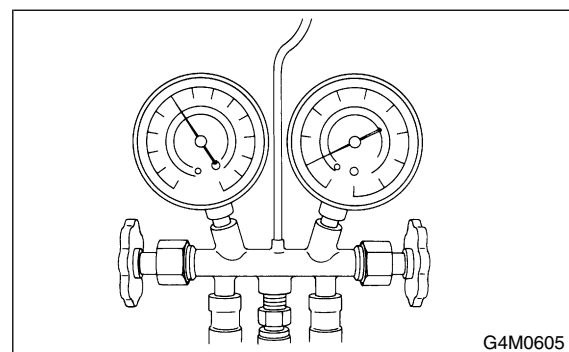

REFRIGERANT CHARGING PROCEDURE

HVAC System (Heater, Ventilator and A/C)

19) If the HFC-134a source is empty, close the high-pressure valve, close the valve on the can tap, and replace the HFC-134a source with a new one to restart the operation.

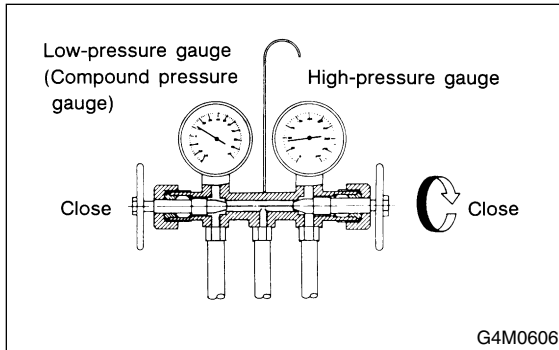

20) Confirm that both the low and high pressure valves can be closed. Start the engine with the A/C switch OFF.

21) Quickly repeat ON-OFF cycles a few times to prevent initial compressor damage.

22) Set up the vehicle to the following status:

- A/C switch ON
- Engine running at 1,500 rpm
- Blower speed setting to "HI"
- Temperature setting to "MAX COOL"
- Air inlet setting to "RECIRC"
- Windows open

23) While reading the low-pressure gauge, carefully open the low-pressure valve with the refrigerant source connected and the service hose purged.

CAUTION:

Never open the high-pressure valve with the engine running.

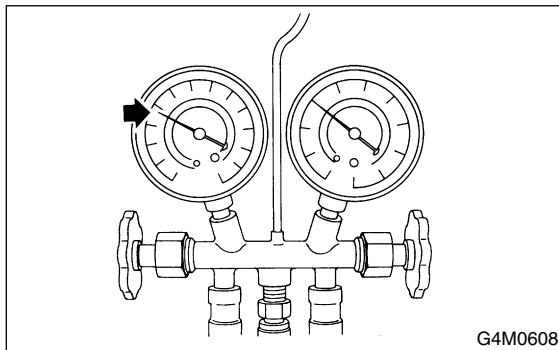

24) Adjust the refrigerant flow to maintain the pressure on the low-pressure side at 276 kPa (2.81 kg/cm², 40 psi) max.

25) After the system is fully charged, close the low-pressure valve.

26) Close the valve on the refrigerant source.

Refrigerant amount		
Refrigerant	Minimum	Maximum
HFC-134a	LHD	0.6 kg (1.3 lb)
	RHD	0.4 kg (0.9 lb)

27) Disconnect the hose from the service port, and install the service port cap.

REFRIGERANT CHARGING PROCEDURE

HVAC System (Heater, Ventilator and A/C)

4. Refrigerant Charging Procedure

S701292

A: OPERATION

S701292A16

CAUTION:

- During operation, be sure to wear safety goggles and protective gloves.
- Before charging the refrigerant, evacuate the system to remove small amounts of moisture remaining in the system. The moisture in the system can be completely evacuated only under the minimum vacuum level. The minimum vacuum level affects the temperature in the system.
- The list below shows the vacuum values necessary to boil water in various temperature. In addition, the vacuum levels indicated on the gauge are approx. 3.3 kPa (25 mmHg, 0.98 inHg) lower than those measured at 304.8 m (1,000 ft) above sea level.

Vacuum level required to boil water (at sea level)	
Temperature	Vacuum
1.7°C (35°F)	100.9 kPa (757 mmHg, 29.8 inHg)
7.2°C (45°F)	100.5 kPa (754 mmHg, 29.7 inHg)
12.8°C (55°F)	99.8 kPa (749 mmHg, 29.5 inHg)
18.3°C (65°F)	99.2 kPa (744 mmHg, 29.3 inHg)
23.9°C (75°F)	98.5 kPa (739 mmHg, 29.1 inHg)
29.4°C (85°F)	97.2 kPa (729 mmHg, 28.7 inHg)
35°C (95°F)	95.8 kPa (719 mmHg, 28.3 inHg)

- 1) Close the valves on low-/high-pressure sides of the manifold gauge.

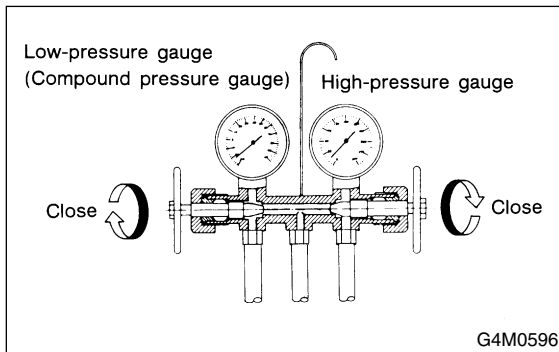

- 2) Install the low-/high-pressure hoses to the corresponding service ports on the vehicle respectively.
- 3) Connect the center hose of the manifold gauge set with the vacuum pump.

- 4) Carefully open the valves on the low-/high-pressure sides to activate the vacuum pump.

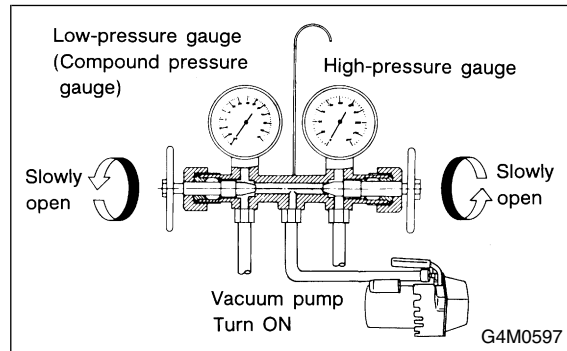

- 5) After the low-pressure gauge reaches 100.0 kPa (750 mmHg, 29.5 inHg) or higher, evacuate the system for approx. 15 minutes.

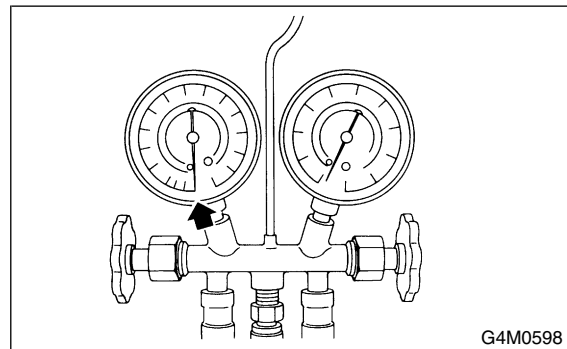

- 6) After 15 minutes of evacuation, if the reading shows 100.0 kPa (750 mmHg, 29.5 inHg) or higher, close the valves on the both sides to stop the vacuum pump.

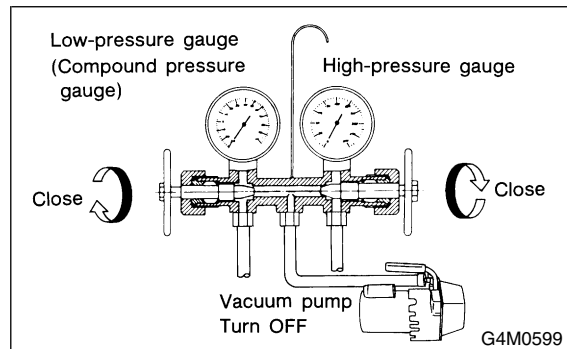

- 7) Note the low-pressure gauge reading.

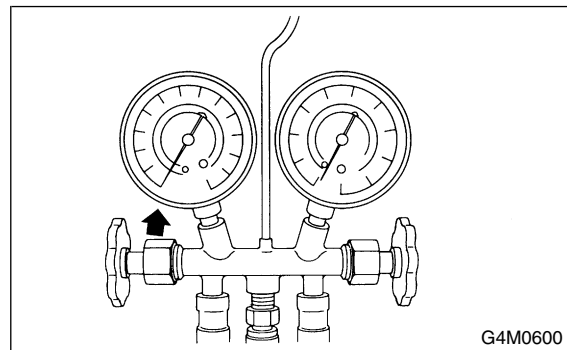

REFRIGERANT CHARGING PROCEDURE

HVAC System (Heater, Ventilator and A/C)

- 8) Leave it at least 5 minutes, and then check the low-pressure gauge reading for any changes. When a gauge indicator shows near to zero point, this is a sign of leakage. Check pipe connector points, repair them, make sure there is no leakage by air bleeding.
- 9) Following the can tap operation manual instructions, install it to the refrigerant can.

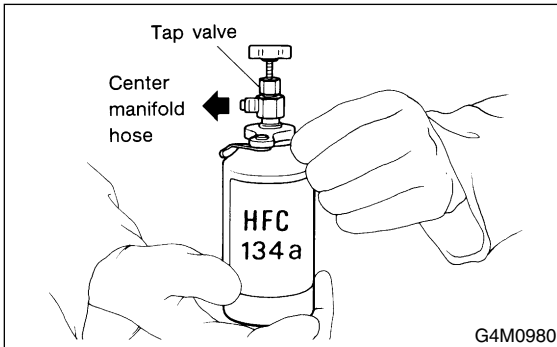

- 10) Disconnect the center manifold hose from the vacuum pump, and connect the hose to the tap valve.

- 11) When a 13.6 kg (30 lb) refrigerant container is used, measure the refrigerant amount in use using a weighting scale.

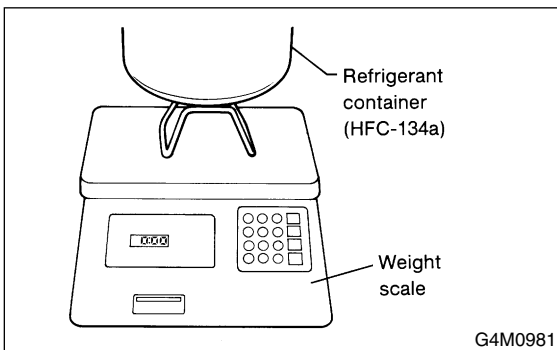

- 12) Confirm that all the 3 hoses are tightly connected to the manifold gauge set.

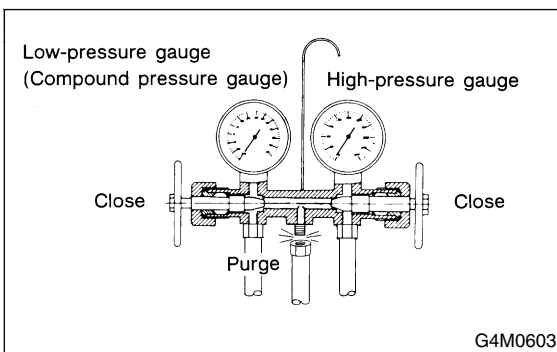

- 13) Open the valve on the HFC-134a source.
- 14) Loosen the center hose connection on the manifold gauge set (if applicable, press a purge valve on the manifold gauge set) only for a couple of seconds to allow the air in the center hose to escape by the refrigerant.

- 15) Carefully open the high-pressure valve with the engine OFF.

CAUTION:
Do not open the low-pressure valve.

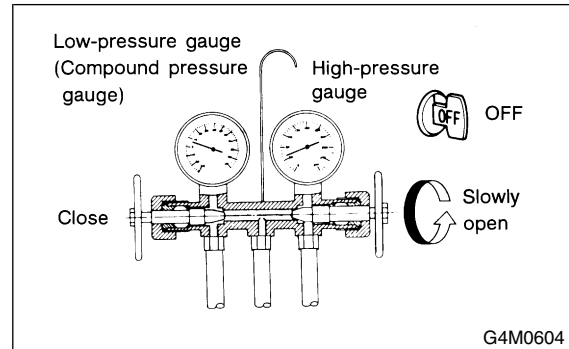

CAUTION:
Never run the engine during charging from the high-pressure side.

- 16) Close the high-pressure valve when the low-pressure gauge reaches 98 kPa (1 kg/cm², 14 psi). Using a leak tester, check the system for leaks. If any leakage is found after the refrigerant recovery is completed, repair the applicable area.

- 17) After confirming that there are no leaks with the leak test, charge the required amount of refrigerant.

CAUTION:
Never run the engine during charging from the high-pressure side.

- 18) Close the high-pressure valve when;
- the readings of low- and high-pressure gauges become almost equal, after the charging speed is reduced,
 - the HFC-134a source becomes empty, or
 - the system is filled with the gas.

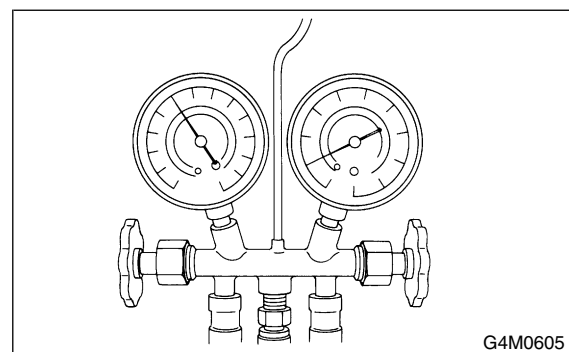

REFRIGERANT CHARGING PROCEDURE

HVAC System (Heater, Ventilator and A/C)

19) If the HFC-134a source is empty, close the high-pressure valve, close the valve on the can tap, and replace the HFC-134a source with a new one to restart the operation.

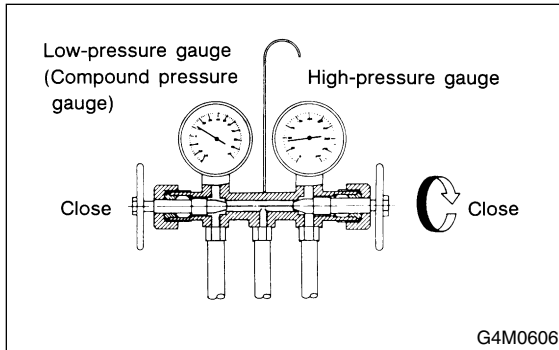

20) Confirm that both the low and high pressure valves can be closed. Start the engine with the A/C switch OFF.

21) Quickly repeat ON-OFF cycles a few times to prevent initial compressor damage.

22) Set up the vehicle to the following status:

- A/C switch ON
- Engine running at 1,500 rpm
- Blower speed setting to "HI"
- Temperature setting to "MAX COOL"
- Air inlet setting to "RECIRC"
- Windows open

23) While reading the low-pressure gauge, carefully open the low-pressure valve with the refrigerant source connected and the service hose purged.

CAUTION:

Never open the high-pressure valve with the engine running.

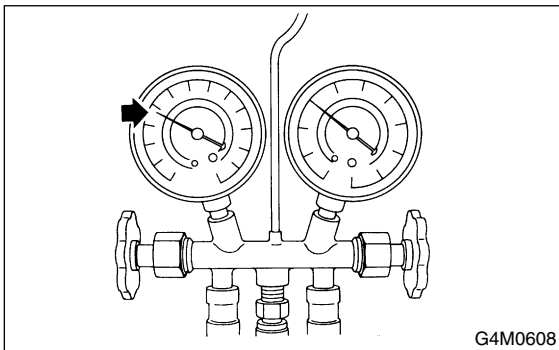

24) Adjust the refrigerant flow to maintain the pressure on the low-pressure side at 276 kPa (2.81 kg/cm², 40 psi) max.

25) After the system is fully charged, close the low-pressure valve.

26) Close the valve on the refrigerant source.

Refrigerant amount		
Refrigerant	Minimum	Maximum
HFC-134a	LHD	0.6 kg (1.3 lb)
	RHD	0.4 kg (0.9 lb)
		0.7 kg (1.5 lb)
		0.5 kg (1.1 lb)

27) Disconnect the hose from the service port, and install the service port cap.

REFRIGERANT LEAK CHECK

HVAC System (Heater, Ventilator and A/C)

5. Refrigerant Leak Check S701293

A: INSPECTION S701293A10

1) Operate the A/C system for approx. 10 minutes, and confirm that the high-side pressure shows at least 690 kPa (7.03 kg/cm², 100 psi). Then stop the engine to start the leak test.

2) Starting from the connection between the high-pressure tube and evaporator, check the system for leaks along the high-pressure side through the compressor. The following items must be checked thoroughly.

- Connection between the tube and tube fitting

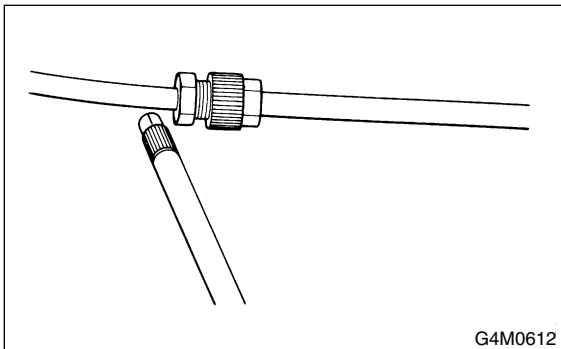

- Connection between 2 parts

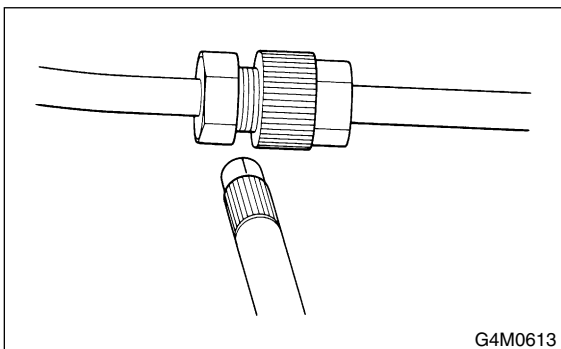

- Connection between the tube and nut

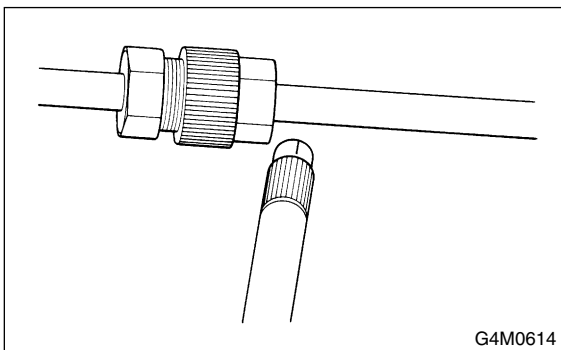

3) Check the joint and seam between the pressure switch (dual switch) and receiver dryer.

4) Check the connections between the condenser and tubes, and welded joints on the condenser. The leak tester may detect the oil on the condenser fins as a leak.

5) Check the joint between the compressor and hoses.

6) Check the machined area of compressor and other joints on the compressor.

7) Check the thermal limiter (if equipped) on the compressor housing.

8) Check the compressor shaft seal at the area near the center of compressor clutch pulley.

Some shaft seals show a slight amount of leakage about 28 g (1.0 oz) per year. This is not a problem.

9) Starting from the connection between the low-pressure tube and evaporator, check the system for leakage along the high-pressure side through the compressor. The following items must be checked thoroughly.

- Connection between the tube and tube fitting
- Connection between 2 parts
- Connection between the tube and nut

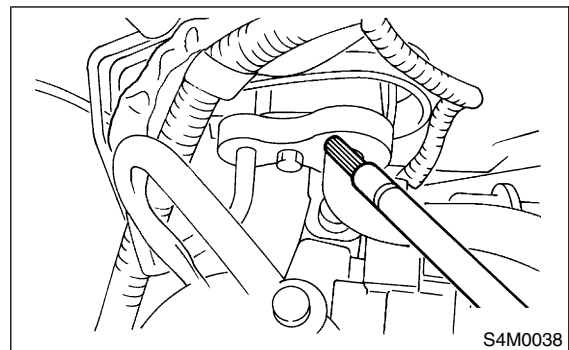

10) Visually check the rubber area of the flexible hose for cracks.

Check the entire length of the flexible hose, especially the connection with the metal hose end.

CAUTION:

Carefully check the external surface of hoses and tubes at approx. 25 mm (0.98 in) per second.

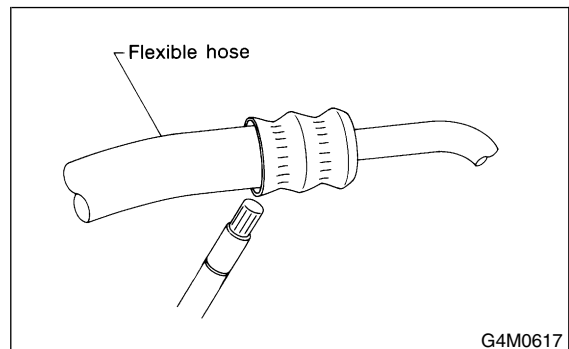

11) Disconnect the drain hose from the evaporator case, and check the hose end for at least 10 seconds.

After the test is finished, reconnect the drain hose.

REFRIGERANT LEAK CHECK

HVAC System (Heater, Ventilator and A/C)

12) Turn the ignition key to ON position, and run the blower at high speed for 1 minute. Stop the blower to check the ventilation grille on the instrument panel. While moving the tester closer to the grille, run the blower for 1 or 2 seconds, then stop it. Check the grille at that point for at least 10 seconds.

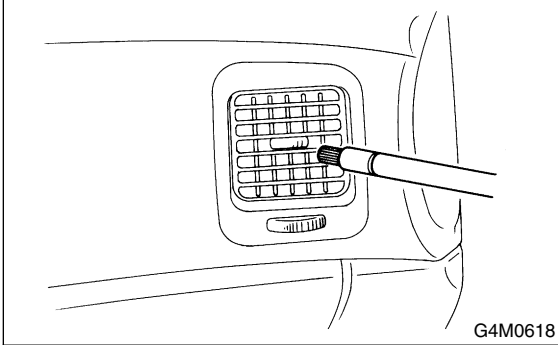

13) Check the valve in the service port.
14) Visually check the rubber seal in the service port cap.

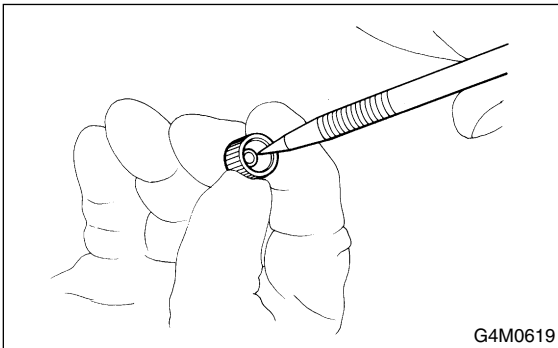

REFRIGERANT LEAK CHECK

HVAC System (Heater, Ventilator and A/C)

5. Refrigerant Leak Check S701293

A: INSPECTION S701293A10

1) Operate the A/C system for approx. 10 minutes, and confirm that the high-side pressure shows at least 690 kPa (7.03 kg/cm², 100 psi). Then stop the engine to start the leak test.

2) Starting from the connection between the high-pressure tube and evaporator, check the system for leaks along the high-pressure side through the compressor. The following items must be checked thoroughly.

- Connection between the tube and tube fitting

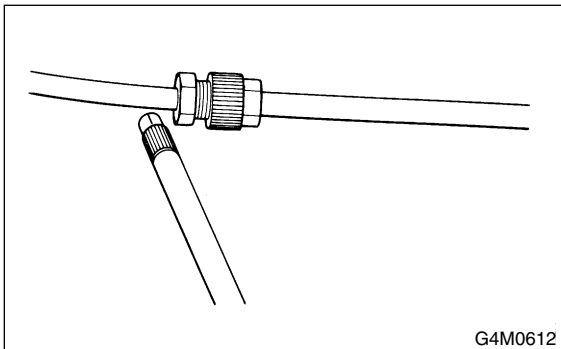

- Connection between 2 parts

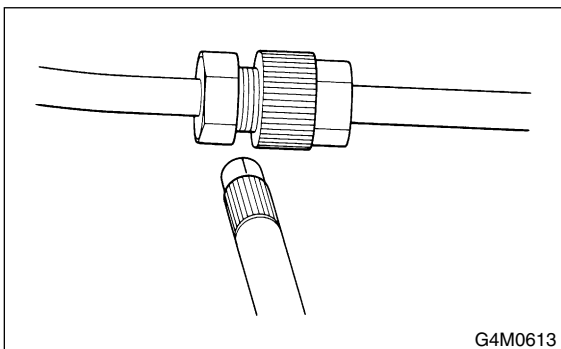

- Connection between the tube and nut

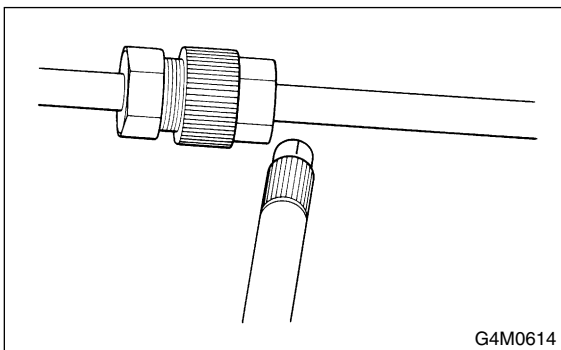

3) Check the joint and seam between the pressure switch (dual switch) and receiver dryer.

4) Check the connections between the condenser and tubes, and welded joints on the condenser. The leak tester may detect the oil on the condenser fins as a leak.

5) Check the joint between the compressor and hoses.

6) Check the machined area of compressor and other joints on the compressor.

7) Check the thermal limiter (if equipped) on the compressor housing.

8) Check the compressor shaft seal at the area near the center of compressor clutch pulley.

Some shaft seals show a slight amount of leakage about 28 g (1.0 oz) per year. This is not a problem.

9) Starting from the connection between the low-pressure tube and evaporator, check the system for leakage along the high-pressure side through the compressor. The following items must be checked thoroughly.

- Connection between the tube and tube fitting
- Connection between 2 parts
- Connection between the tube and nut

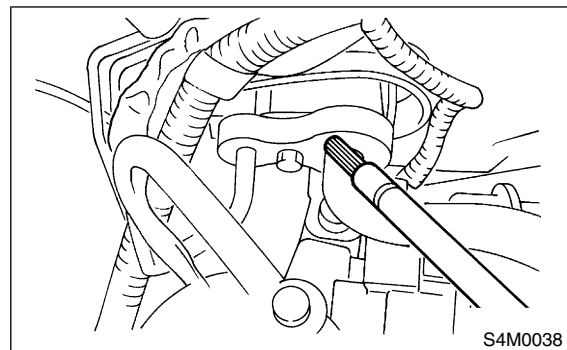

10) Visually check the rubber area of the flexible hose for cracks.

Check the entire length of the flexible hose, especially the connection with the metal hose end.

CAUTION:

Carefully check the external surface of hoses and tubes at approx. 25 mm (0.98 in) per second.

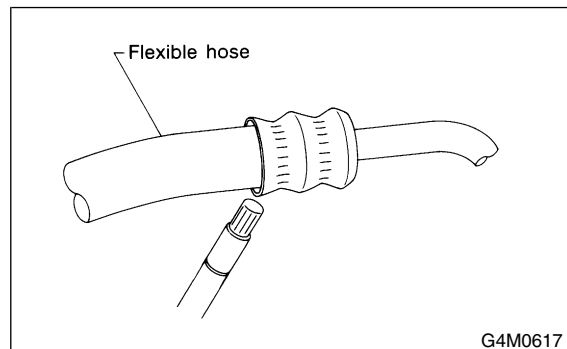

11) Disconnect the drain hose from the evaporator case, and check the hose end for at least 10 seconds.

After the test is finished, reconnect the drain hose.

REFRIGERANT LEAK CHECK

HVAC System (Heater, Ventilator and A/C)

12) Turn the ignition key to ON position, and run the blower at high speed for 1 minute. Stop the blower to check the ventilation grille on the instrument panel. While moving the tester closer to the grille, run the blower for 1 or 2 seconds, then stop it. Check the grille at that point for at least 10 seconds.

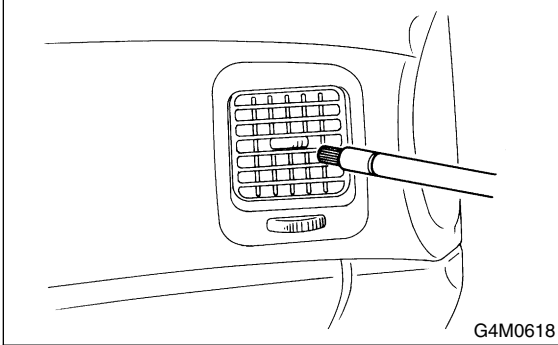

13) Check the valve in the service port.
14) Visually check the rubber seal in the service port cap.

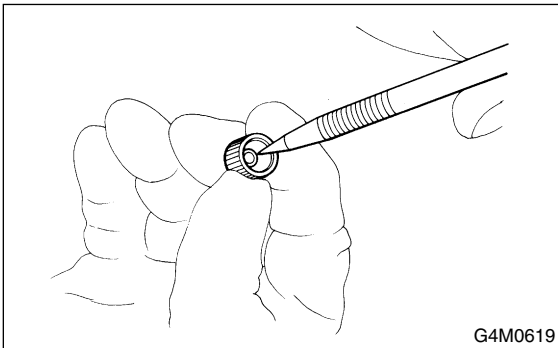

COMPRESSOR OIL

HVAC System (Heater, Ventilator and A/C)

6. Compressor Oil S701294

A: OPERATION S701294A16

NOTE:

Before making repairs, conduct the oil return operation to return the compressor oil in circulation with the refrigerant to the compressor.

- 1) Increase engine to 1,500 rpm.
- 2) Turn ON the A/C switch.
- 3) Turn the temperature control switch to MAX COOL.
- 4) Put in RECIRC position.
- 5) Turn the blower control switch to HI.
- 6) Leave in this condition for 10 minutes.

B: REPLACEMENT S701294A20

NOTE:

- If a component is replaced, add an appropriate amount of compressor oil.
- When replacing the compressor, the new compressor will already have the specified amount of oil in it. Install the new compressor after removing the same amount of oil that is remaining in the compressor removed.

Replacement parts	Amount of oil replenishment
Evaporator	114 ml (3.9 US fl oz, 4.0 Imp fl oz)
Receiver drier	5 ml (0.2 US fl oz, 0.2 Imp fl oz)
Condenser	2 ml (0.07 US fl oz, 0.07 Imp fl oz)
Hose	1 ml (0.03 US fl oz, 0.04 Imp fl oz)

COMPRESSOR OIL

HVAC System (Heater, Ventilator and A/C)

6. Compressor Oil S701294

A: OPERATION S701294A16

NOTE:

Before making repairs, conduct the oil return operation to return the compressor oil in circulation with the refrigerant to the compressor.

- 1) Increase engine to 1,500 rpm.
- 2) Turn ON the A/C switch.
- 3) Turn the temperature control switch to MAX COOL.
- 4) Put in RECIRC position.
- 5) Turn the blower control switch to HI.
- 6) Leave in this condition for 10 minutes.

B: REPLACEMENT S701294A20

NOTE:

- If a component is replaced, add an appropriate amount of compressor oil.
- When replacing the compressor, the new compressor will already have the specified amount of oil in it. Install the new compressor after removing the same amount of oil that is remaining in the compressor removed.

Replacement parts	Amount of oil replenishment
Evaporator	114 ml (3.9 US fl oz, 4.0 Imp fl oz)
Receiver drier	5 ml (0.2 US fl oz, 0.2 Imp fl oz)
Condenser	2 ml (0.07 US fl oz, 0.07 Imp fl oz)
Hose	1 ml (0.03 US fl oz, 0.04 Imp fl oz)

7. Heater Unit S701290

A: REMOVAL S701290A18

- 1) Disconnect ground cable from battery.
- 2) Pull out LLC.
- 3) Remove air cleaner case.
- 4) Release heater hose clamps in engine compartment to remove the hoses.

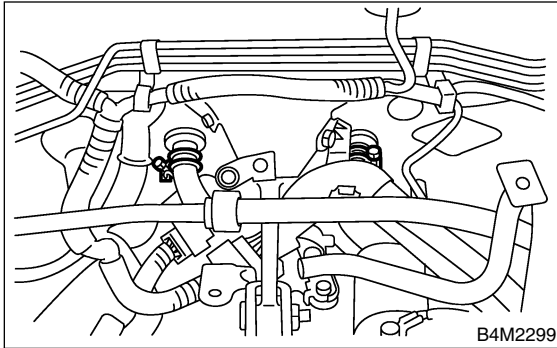

- 5) Remove A/C unit. <Ref. to AC-36, REMOVAL, Intake Unit.>
- 6) Using a Torx wrench, remove airbag control unit.

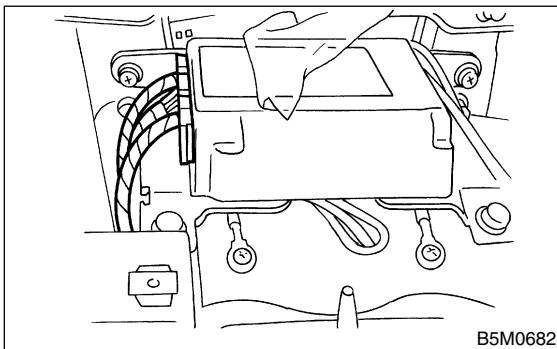

- 7) Disconnect connector of airbag main harness near steering support beam.

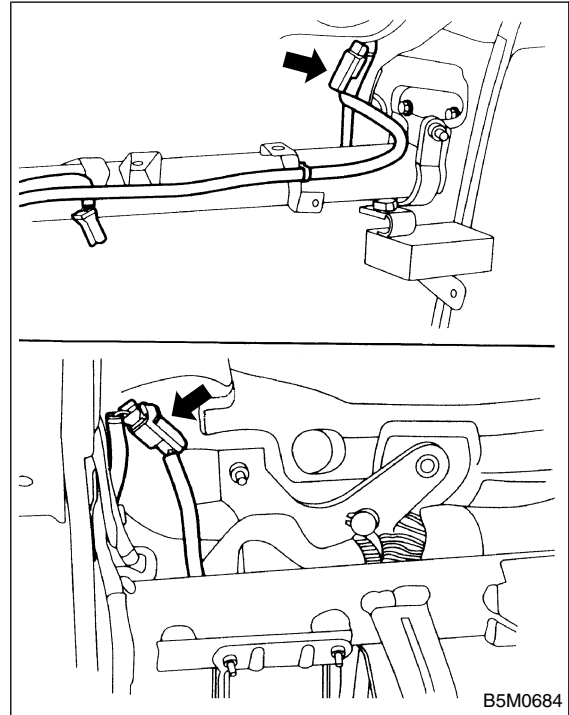

- 8) Loosen bolts and nuts of support beam to remove support beam.
- 9) Disconnect servo connector.
- 10) Loosen bolts and nuts of heater unit to remove heater unit.

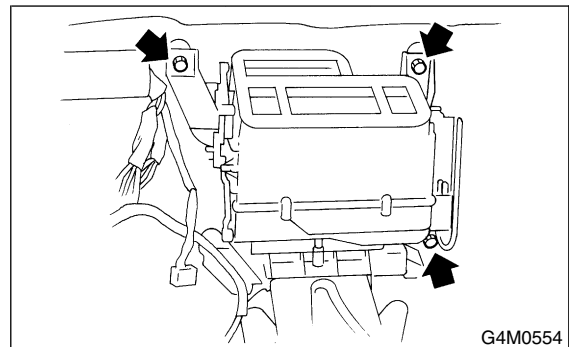

B: INSTALLATION S701290A11

Install in the reverse order of removal.

Tightening torque:

Refer to COMPONENT of General Description

<Ref to. AC-5, HEATER UNIT, COMPONENT, General Description.>

7. Heater Unit S701290

A: REMOVAL S701290A18

- 1) Disconnect ground cable from battery.
- 2) Pull out LLC.
- 3) Remove air cleaner case.
- 4) Release heater hose clamps in engine compartment to remove the hoses.

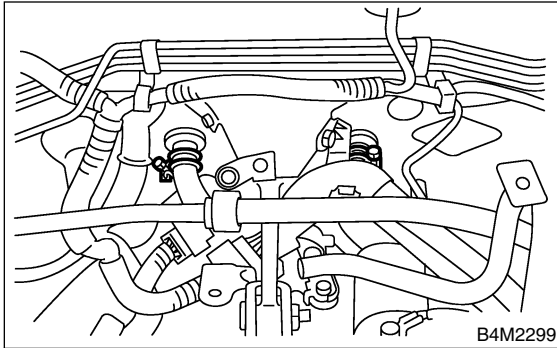

- 5) Remove A/C unit. <Ref. to AC-36, REMOVAL, Intake Unit.>
- 6) Using a Torx wrench, remove airbag control unit.

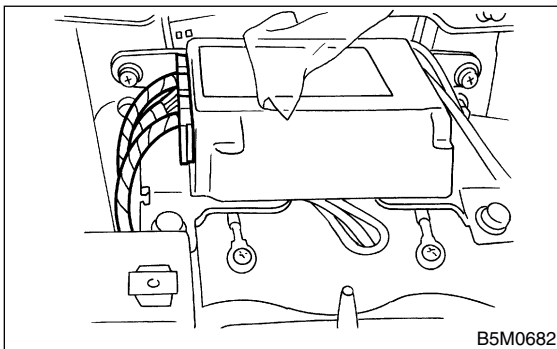

- 7) Disconnect connector of airbag main harness near steering support beam.

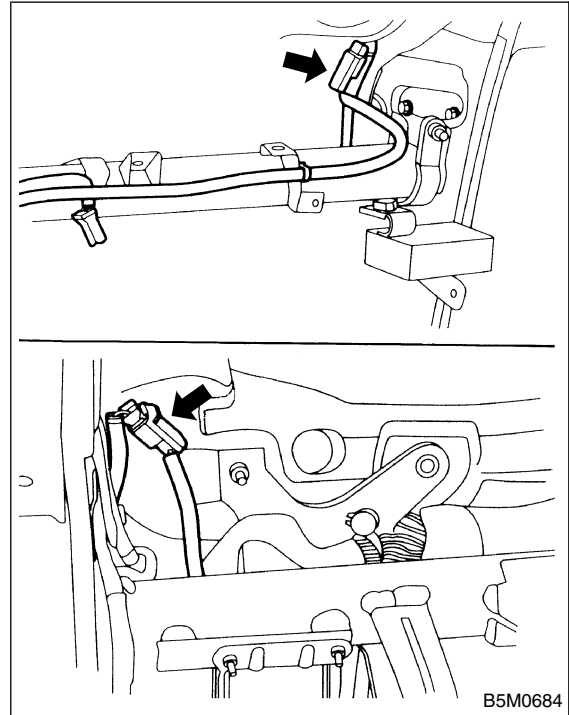

- 8) Loosen bolts and nuts of support beam to remove support beam.
- 9) Disconnect servo connector.
- 10) Loosen bolts and nuts of heater unit to remove heater unit.

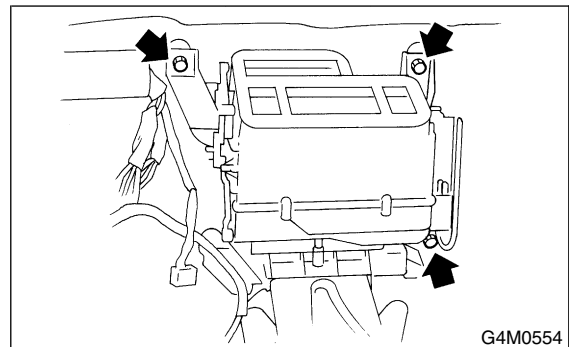

B: INSTALLATION S701290A11

Install in the reverse order of removal.

Tightening torque:

Refer to COMPONENT of General Description

<Ref to. AC-5, HEATER UNIT, COMPONENT, General Description.>

BLOWER MOTOR ASSEMBLY

HVAC System (Heater, Ventilator and A/C)

8. Blower Motor Assembly S701295

A: REMOVAL S701295A18

- 1) Disconnect ground cable from battery.
- 2) Remove glove box. <Ref. to EI-34, REMOVAL, Glove Box.>
- 3) Remove mounting bolts of harness stay.

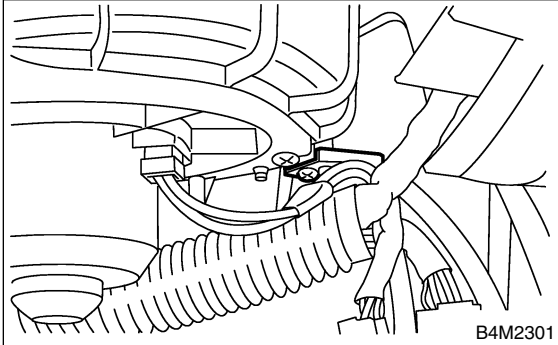

- 4) Remove nuts of keyless unit stay and CRU unit stay.

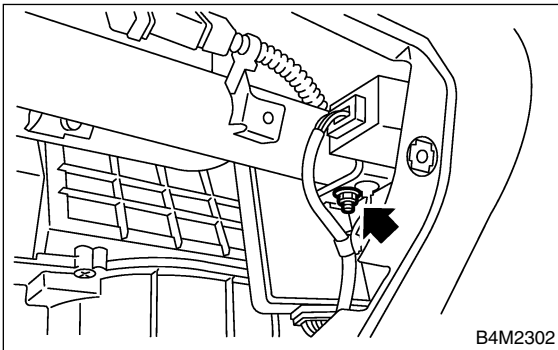

- 5) Disconnect connector of sunroof.
- 6) Disconnect servo connector.

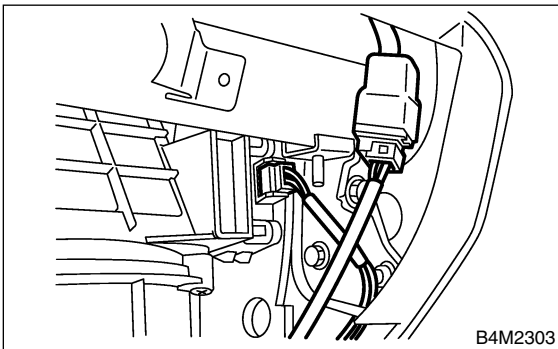

- 7) Disconnect blower motor connector.

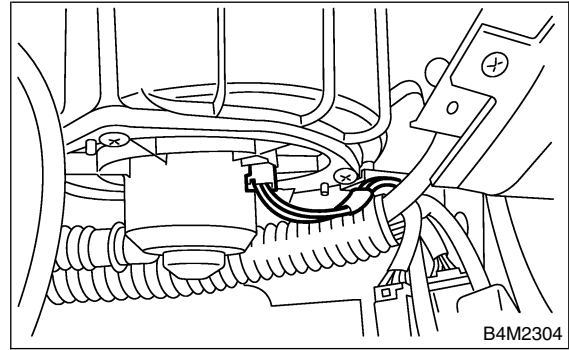

- 8) Remove 3 screws.
- 9) Disconnect aspirator pipe (A) and remove blower motor.

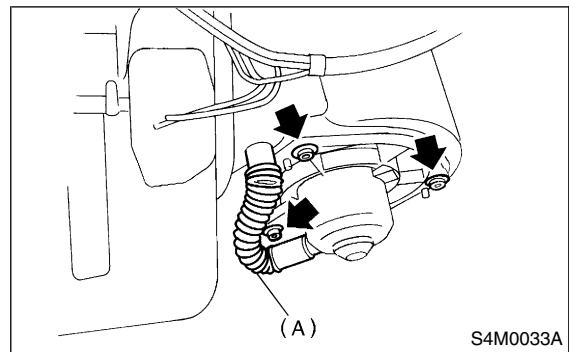

B: INSTALLATION S701295A11

Install in the reverse order of removal.

C: INSPECTION S701295A10

Connect motor connector terminal 1 from the battery to the positive (+) lead and terminal 2 to the negative (-) lead. Make sure the motor runs smoothly.

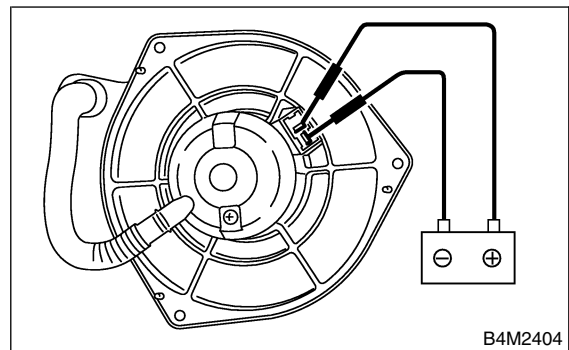

BLOWER MOTOR ASSEMBLY

HVAC System (Heater, Ventilator and A/C)

8. Blower Motor Assembly S701295

A: REMOVAL S701295A18

- 1) Disconnect ground cable from battery.
- 2) Remove glove box. <Ref. to EI-34, REMOVAL, Glove Box.>
- 3) Remove mounting bolts of harness stay.

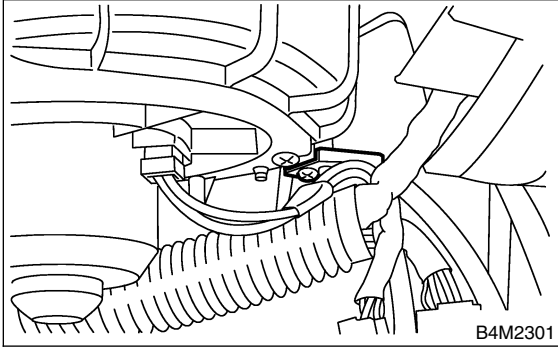

- 4) Remove nuts of keyless unit stay and CRU unit stay.

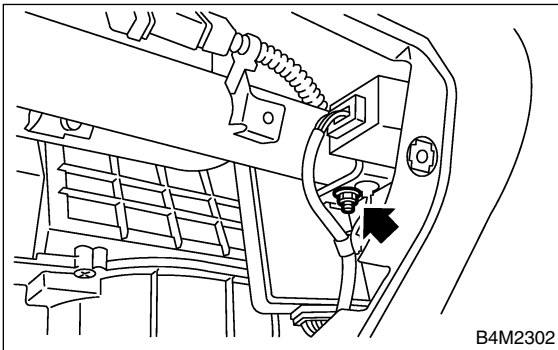

- 5) Disconnect connector of sunroof.
- 6) Disconnect servo connector.

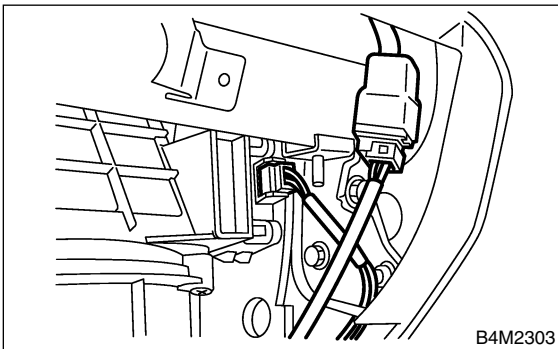

- 7) Disconnect blower motor connector.

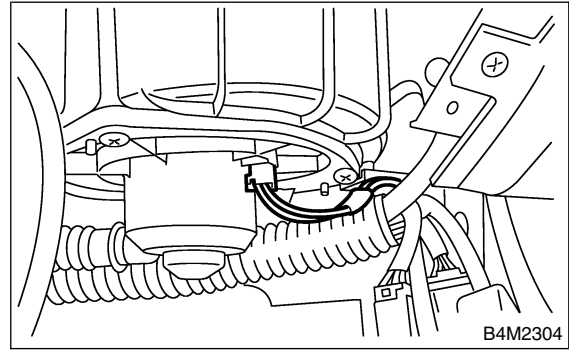

- 8) Remove 3 screws.
- 9) Disconnect aspirator pipe (A) and remove blower motor.

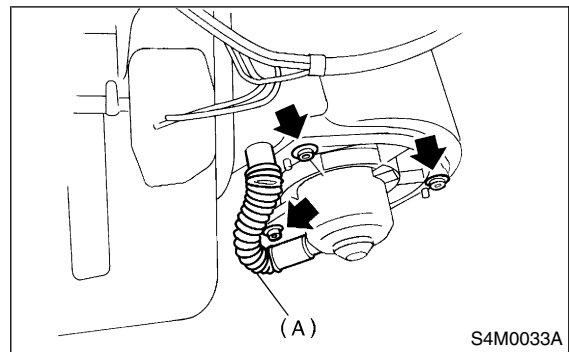

B: INSTALLATION S701295A11

Install in the reverse order of removal.

C: INSPECTION S701295A10

Connect motor connector terminal 1 from the battery to the positive (+) lead and terminal 2 to the negative (-) lead. Make sure the motor runs smoothly.

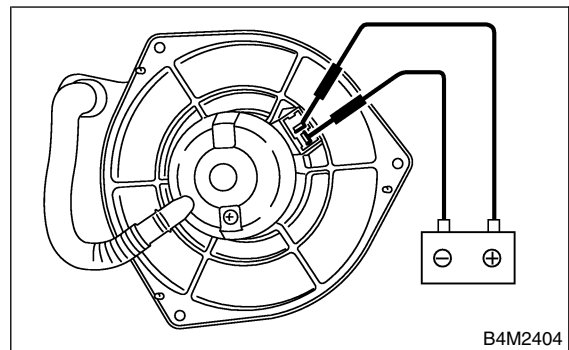

9. Power Transistor (Heater Blower Resistor) S701553

A: REMOVAL S701553A18

- 1) Remove glove box. <Ref. to EI-34, REMOVAL, Glove Box.>
- 2) Disconnect power transistor connector.
- 3) Loosen 2 screws to remove power transistor.

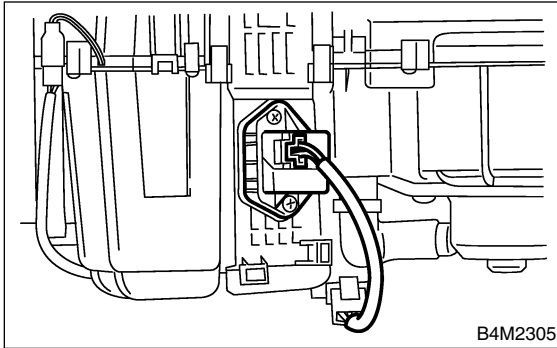

B: INSTALLATION S701553A11

Install in the reverse order of removal.

POWER TRANSISTOR (HEATER BLOWER RESISTOR)

HVAC System (Heater, Ventilator and A/C)

C: INSPECTION S701553A10

1. MANUAL A/C S701553A1002

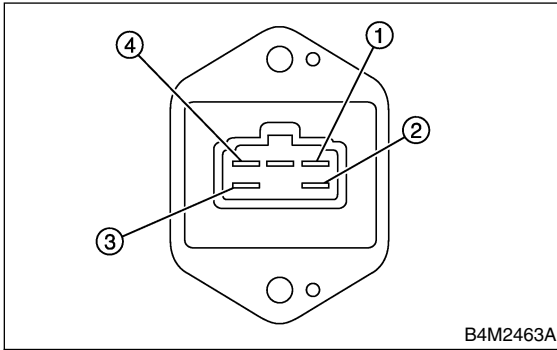

Measure switch resistance.

Terminal No.	Condition	Standard
4 and 3	Constant	Approx. 0.46 Ω
3 and 2	Constant	Approx. 0.85 Ω
2 and 1	Constant	Approx. 1.77 Ω

If NG, replace the blower resistor.

10. Heater Core S701554

A: REMOVAL S701554A18

- 1) Remove heater unit. <Ref. to AC-25, REMOVAL, Heater Unit.>
- 2) Remove screws to separate heater unit case.
- 3) Remove heater core.

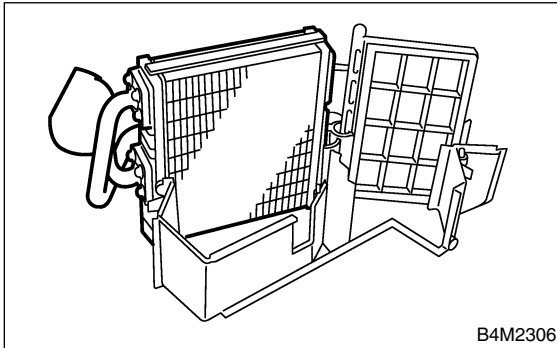

B: INSTALLATION S701554A11

Install in the reverse order of removal.

10. Heater Core S701554

A: REMOVAL S701554A18

- 1) Remove heater unit. <Ref. to AC-25, REMOVAL, Heater Unit.>
- 2) Remove screws to separate heater unit case.
- 3) Remove heater core.

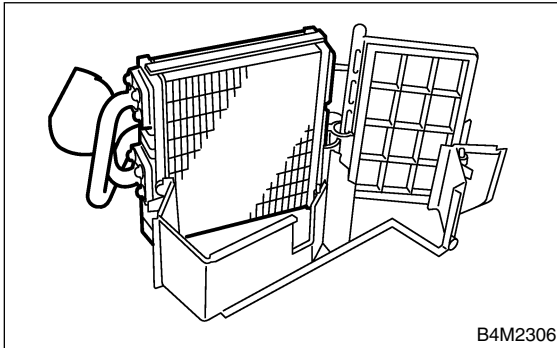

B: INSTALLATION S701554A11

Install in the reverse order of removal.

CONTROL UNIT

HVAC System (Heater, Ventilator and A/C)

11. Control Unit S701285

A: REMOVAL S701285A18

1. AUTO A/C S701285A1801

- 1) Disconnect ground cable from battery.
- 2) Remove front cover (A).
- 3) Loosen 2 screws (B) to remove center panel (C).

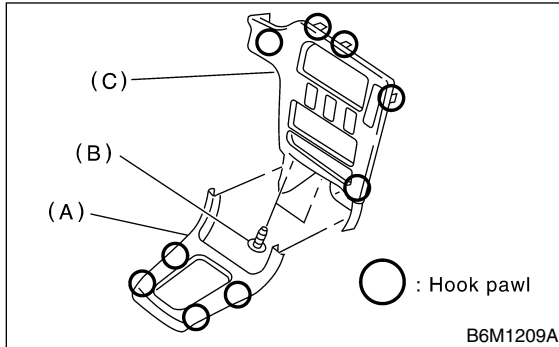

- 4) Loosen screws to pull control unit slightly out of center console.

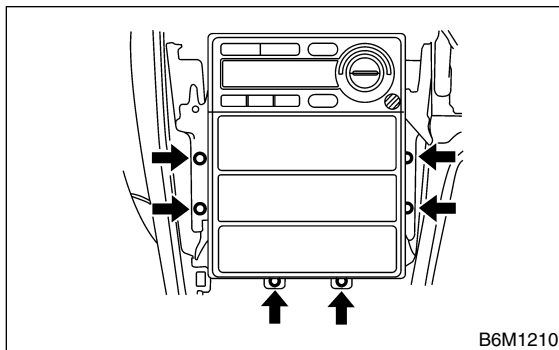

- 5) Disconnect connector to remove control unit.

2. MANUAL A/C S701285A1802

- 1) Disconnect ground cable from battery.
- 2) Remove front cover (A).
- 3) Loosen 2 screws (B) to remove center panel (C).

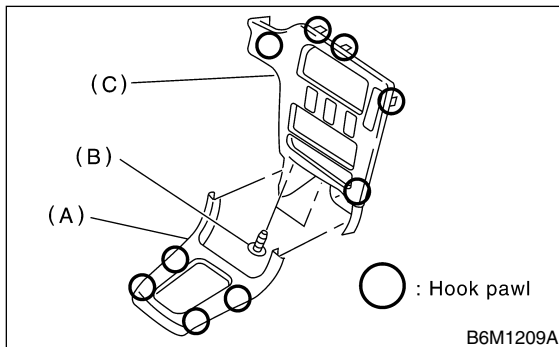

- 4) Set temperature control switch to "FULL HOT", and disconnect temperature control cable from heater unit.

- 5) Loosen screws to pull control unit slightly out of center console.

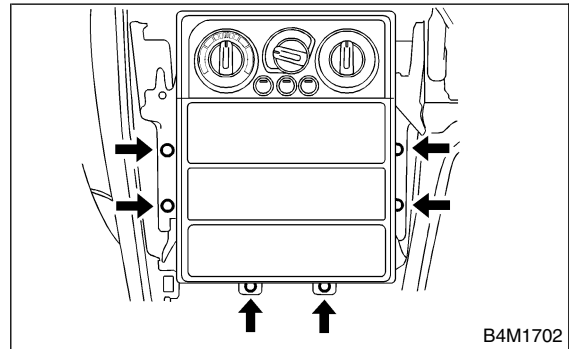

- 6) Disconnect connector from antenna cable to remove control unit.

B: INSTALLATION S701285A11

1. AUTO A/C S701285A1101

Install in the reverse order of removal.

2. MANUAL A/C S701285A1102

- 1) Install in the reverse order of removal.
- 2) Before installation, set temperature control switch to "FULL HOT".

CONTROL UNIT

HVAC System (Heater, Ventilator and A/C)

11. Control Unit S701285

A: REMOVAL S701285A18

1. AUTO A/C S701285A1801

- 1) Disconnect ground cable from battery.
- 2) Remove front cover (A).
- 3) Loosen 2 screws (B) to remove center panel (C).

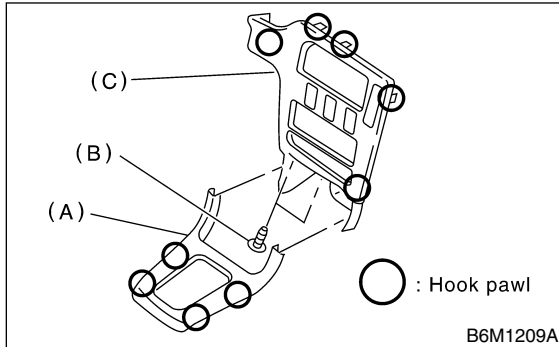

- 4) Loosen screws to pull control unit slightly out of center console.

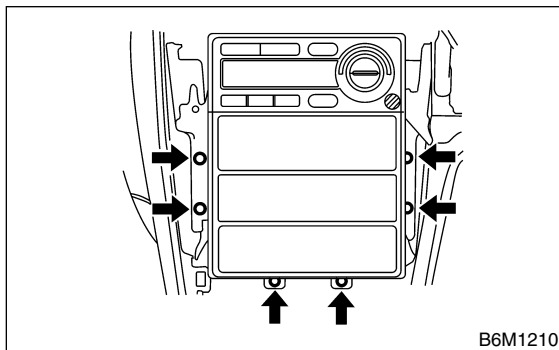

- 5) Disconnect connector to remove control unit.

2. MANUAL A/C S701285A1802

- 1) Disconnect ground cable from battery.
- 2) Remove front cover (A).
- 3) Loosen 2 screws (B) to remove center panel (C).

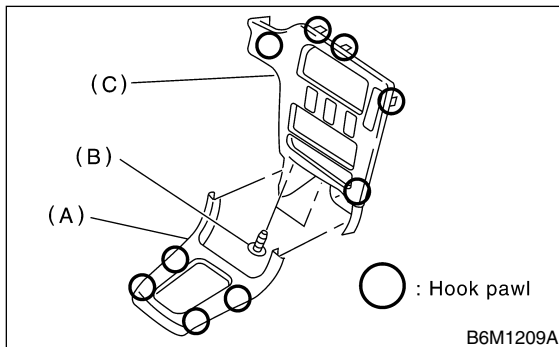

- 4) Set temperature control switch to "FULL HOT", and disconnect temperature control cable from heater unit.

- 5) Loosen screws to pull control unit slightly out of center console.

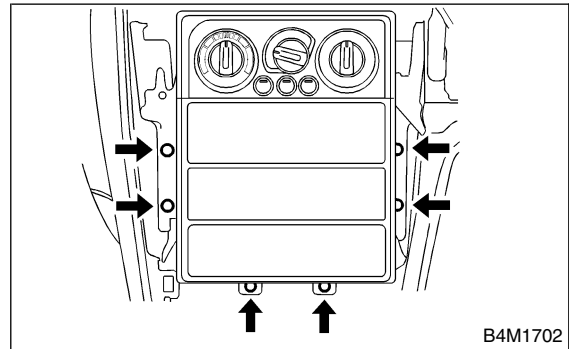

- 6) Disconnect connector from antenna cable to remove control unit.

B: INSTALLATION S701285A11

1. AUTO A/C S701285A1101

Install in the reverse order of removal.

2. MANUAL A/C S701285A1102

- 1) Install in the reverse order of removal.
- 2) Before installation, set temperature control switch to "FULL HOT".

12. Compressor S701281

A: INSPECTION S701281A10

1. MAGNETIC CLUTCH CLEARANCE

S701281A1001

- 1) Check the clearance of the entire circumference around the drive plate and pulley.

Standard:

0.45±0.15 mm (0.0177±0.0059 in)

2. MAGNETIC CLUTCH OPERATION

S701281A1002

- 1) Disconnect the compressor connector.
- 2) Connect the No. 3 terminal of the compressor connector from the battery to the positive (+) lead. Ground the negative (-) lead to the body.

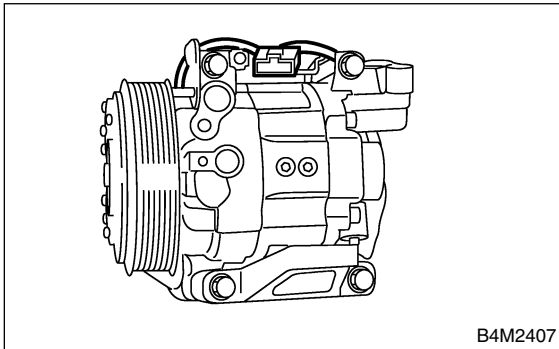

- 3) Make sure the magnet clutch engages. If NG, replace the compressor.

B: REMOVAL S701281A18

- 1) Perform oil return operation. <Ref. to AC-24, OPERATION, Compressor Oil.>
- 2) Turn A/C switch OFF and stop the engine.
- 3) Using refrigerant recovery system, discharge refrigerant. <Ref. to AC-18, OPERATION, Refrigerant Recovery Procedure.>
- 4) Disconnect ground cable from battery.
- 5) Remove duct (A).

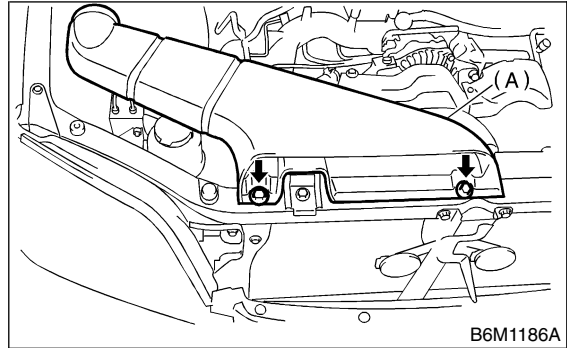

- 6) Disconnect low-pressure hose (A) and high-pressure hose (B).

CAUTION:

Be careful not to lose O-rings on hose. Immediately seal hose with a plug or vinyl tape to prevent the entry of contamination.

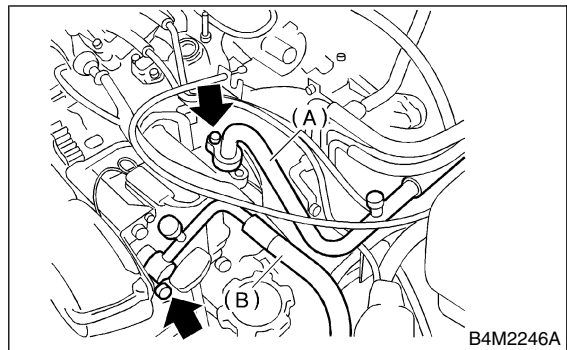

- 7) Remove V-belt. <Ref. to ME-42, REMOVAL, V-belt.>
- 8) Remove generator. <Ref. to SC-15, REMOVAL, Generator.>
- 9) Disconnect compressor harness from body harness.

COMPRESSOR

HVAC System (Heater, Ventilator and A/C)

10) Remove bolts from compressor bracket.

4 CYLINDERS:

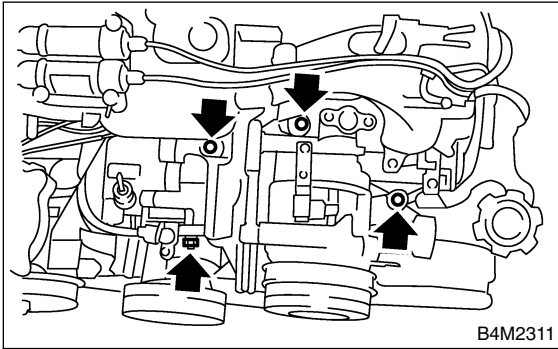

6 CYLINDERS:

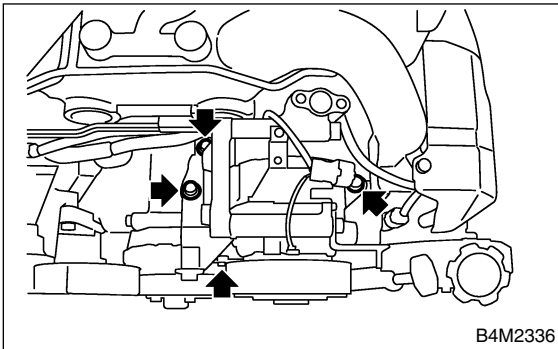

11) Loosen bolts to remove compressor from bracket.

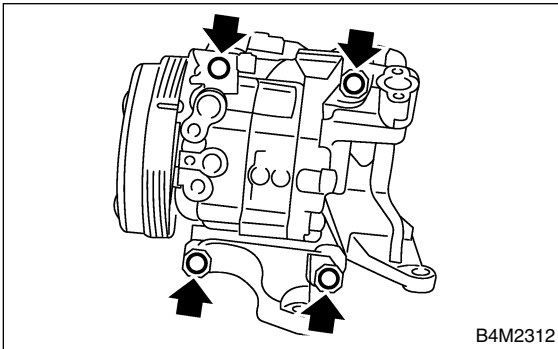

C: INSTALLATION S701281A11

- 1) Install in the reverse order of removal.
- 2) Replace O-rings on low-/high-pressure hoses with new ones, then apply compressor oil.
- 3) When replacing compressor, adjust amount of compressor oil. <Ref. to AC-24, Compressor Oil.>
- 4) Charge refrigerant. <Ref. to AC-19, OPERATION, Refrigerant Charging Procedure.>

Tightening torque:

Refer to COMPONENT of General Description

<Ref. to AC-9, AIR CONDITIONING UNIT, COMPONENT, General Description.>

12. Compressor S701281

A: INSPECTION S701281A10

1. MAGNETIC CLUTCH CLEARANCE

S701281A1001

1) Check the clearance of the entire circumference around the drive plate and pulley.

Standard:

0.45±0.15 mm (0.0177±0.0059 in)

2. MAGNETIC CLUTCH OPERATION

S701281A1002

1) Disconnect the compressor connector.
 2) Connect the No. 3 terminal of the compressor connector from the battery to the positive (+) lead. Ground the negative (-) lead to the body.

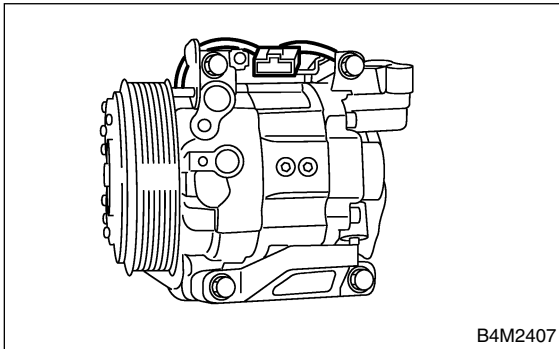

3) Make sure the magnet clutch engages. If NG, replace the compressor.

B: REMOVAL S701281A18

1) Perform oil return operation. <Ref. to AC-24, OPERATION, Compressor Oil.>
 2) Turn A/C switch OFF and stop the engine.
 3) Using refrigerant recovery system, discharge refrigerant. <Ref. to AC-18, OPERATION, Refrigerant Recovery Procedure.>
 4) Disconnect ground cable from battery.
 5) Remove duct (A).

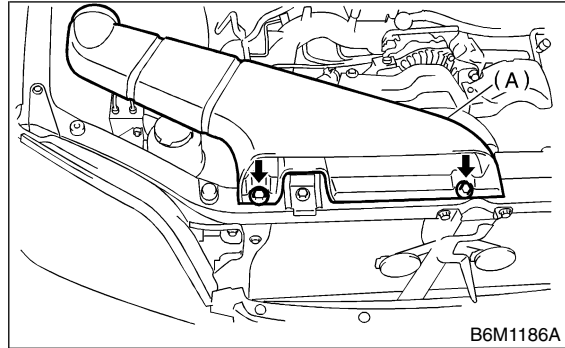

6) Disconnect low-pressure hose (A) and high-pressure hose (B).

CAUTION:

Be careful not to lose O-rings on hose. Immediately seal hose with a plug or vinyl tape to prevent the entry of contamination.

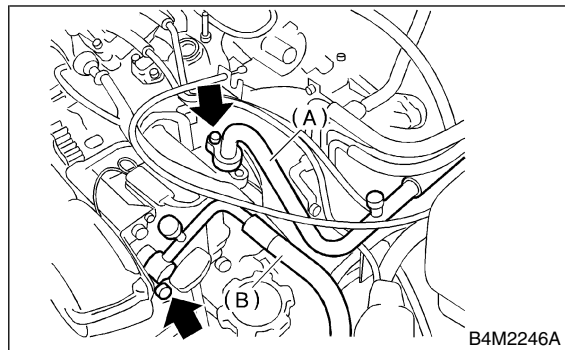

7) Remove V-belt. <Ref. to ME-42, REMOVAL, V-belt.>
 8) Remove generator. <Ref. to SC-15, REMOVAL, Generator.>
 9) Disconnect compressor harness from body harness.

COMPRESSOR

HVAC System (Heater, Ventilator and A/C)

10) Remove bolts from compressor bracket.

4 CYLINDERS:

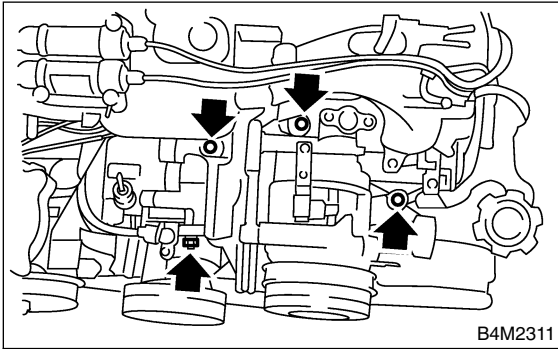

6 CYLINDERS:

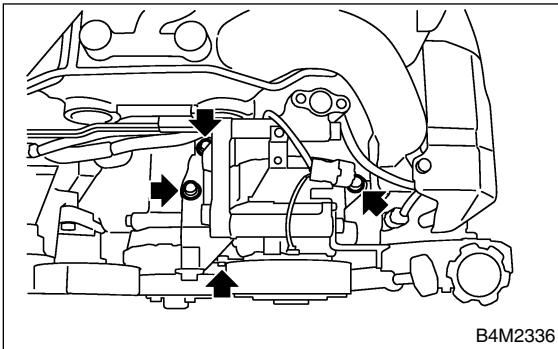

11) Loosen bolts to remove compressor from bracket.

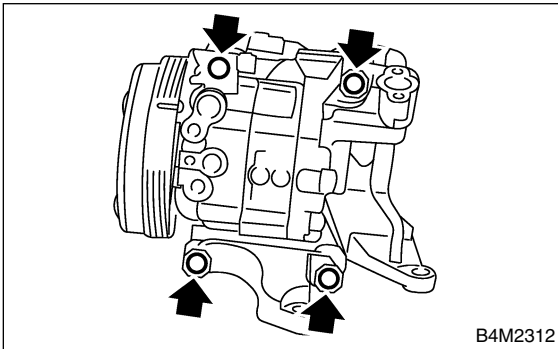

C: INSTALLATION S701281A11

- 1) Install in the reverse order of removal.
- 2) Replace O-rings on low-/high-pressure hoses with new ones, then apply compressor oil.
- 3) When replacing compressor, adjust amount of compressor oil. <Ref. to AC-24, Compressor Oil.>
- 4) Charge refrigerant. <Ref. to AC-19, OPERATION, Refrigerant Charging Procedure.>

Tightening torque:

Refer to COMPONENT of General Description

<Ref. to AC-9, AIR CONDITIONING UNIT, COMPONENT, General Description.>

13. Condenser S701282

A: REMOVAL S701282A18

- 1) Using refrigerant recovery system, discharge refrigerant. <Ref. to AC-18, OPERATION, Refrigerant Recovery Procedure.>
- 2) Disconnect ground cable from battery.
- 3) Remove duct (A).

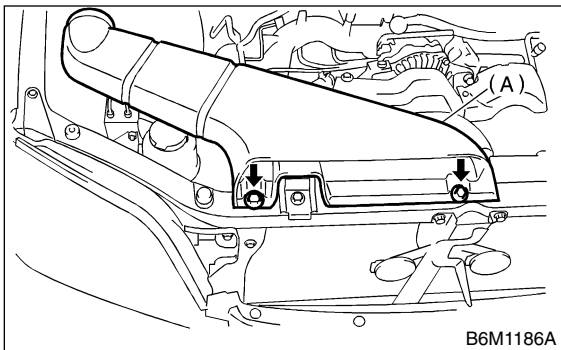

- 4) Disconnect high-pressure hose (A) and low-pressure hose (B) from condenser.

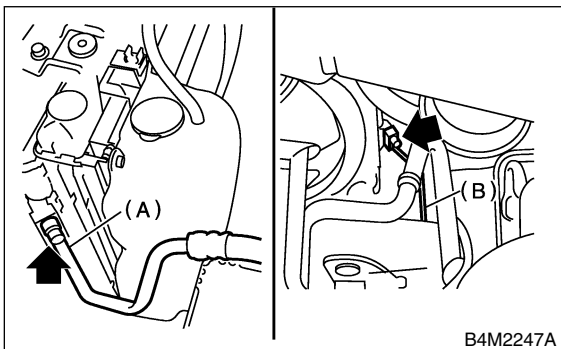

- 5) Remove radiator bracket (A).

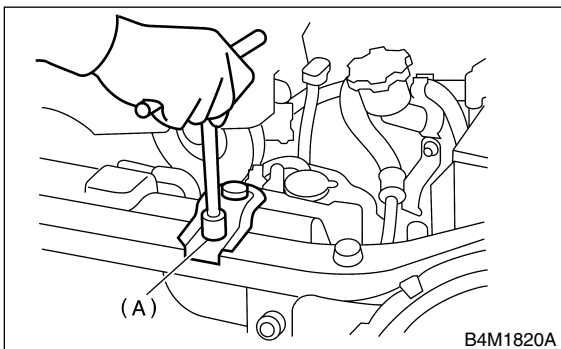

- 6) Remove 2 bolts. While lifting condenser, pull it out through the space between the radiator and the radiator panel.

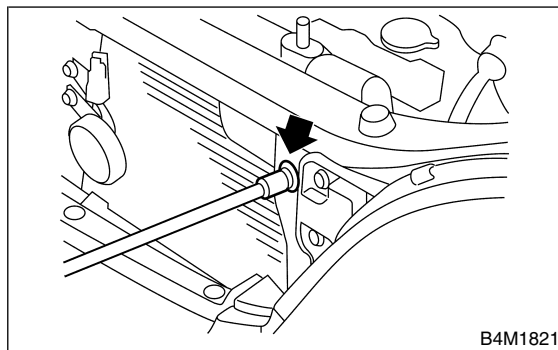

CAUTION:
 Be careful not to damage condenser fins. If a damaged fin is found, repair it using a thin screwdriver.
 If condenser is replaced, add appropriate amount of compressor oil to the compressor. <Ref. to AC-24, REPLACEMENT, Compressor Oil.>

B: INSTALLATION S701282A11

- 1) Install in the reverse order of removal.

CAUTION:
 Replace O-rings on hoses or pipes with new ones, and then apply compressor oil. Confirm that lower guide of condenser has been fitted into holes on radiator panel.

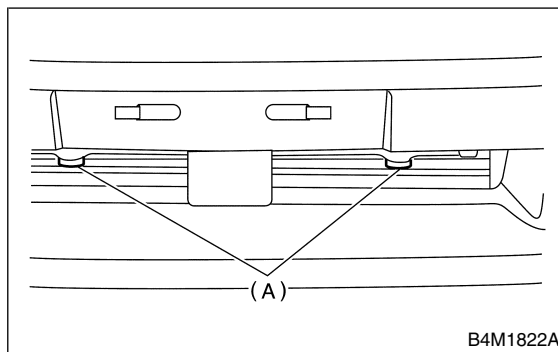

- 2) Charge refrigerant. <Ref. to AC-19, OPERATION, Refrigerant Charging Procedure.>

CONDENSER

HVAC System (Heater, Ventilator and A/C)

C: INSPECTION S701282A10

- 1) Confirm that no dust or insects are found on the condenser fins. Air-blow or flush fins with water as needed.
- 2) Confirm that no oil leaks from condenser. If a failure is found, replace condenser with a new one.

Tightening torque:

Refer to COMPONENT of General

Description

***<Ref. to AC-9, AIR CONDITIONING UNIT,
COMPONENT, General Description.>***

13. Condenser S701282

A: REMOVAL S701282A18

- 1) Using refrigerant recovery system, discharge refrigerant. <Ref. to AC-18, OPERATION, Refrigerant Recovery Procedure.>
- 2) Disconnect ground cable from battery.
- 3) Remove duct (A).

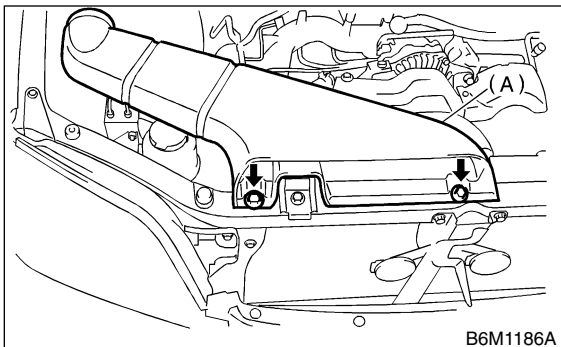

- 4) Disconnect high-pressure hose (A) and low-pressure hose (B) from condenser.

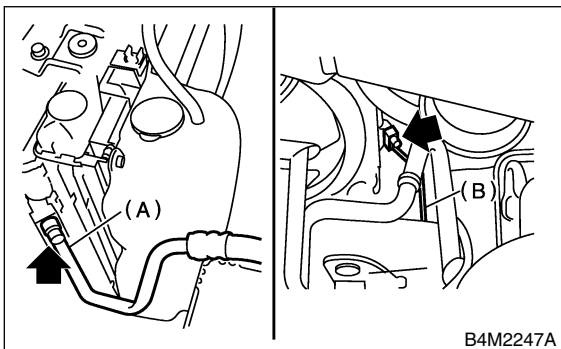

- 5) Remove radiator bracket (A).

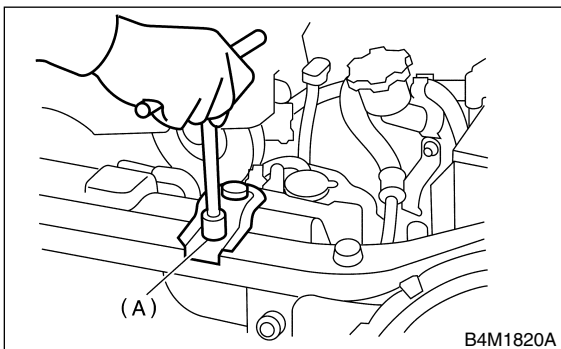

- 6) Remove 2 bolts. While lifting condenser, pull it out through the space between the radiator and the radiator panel.

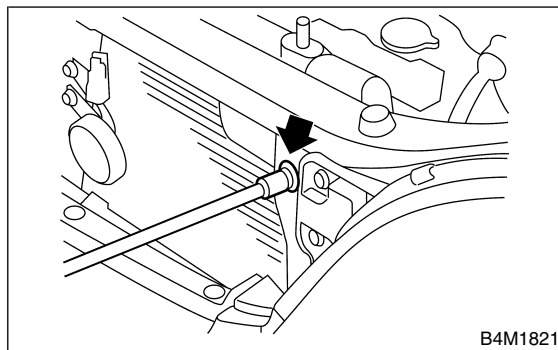

CAUTION:
Be careful not to damage condenser fins. If a damaged fin is found, repair it using a thin screwdriver.

If condenser is replaced, add appropriate amount of compressor oil to the compressor. <Ref. to AC-24, REPLACEMENT, Compressor Oil.>

B: INSTALLATION S701282A11

- 1) Install in the reverse order of removal.

CAUTION:
Replace O-rings on hoses or pipes with new ones, and then apply compressor oil. Confirm that lower guide of condenser has been fitted into holes on radiator panel.

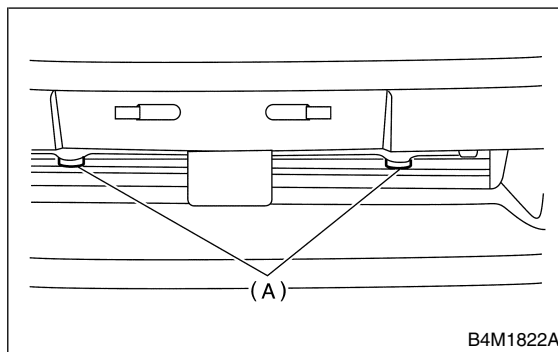

- 2) Charge refrigerant. <Ref. to AC-19, OPERATION, Refrigerant Charging Procedure.>

CONDENSER

HVAC System (Heater, Ventilator and A/C)

C: INSPECTION S701282A10

- 1) Confirm that no dust or insects are found on the condenser fins. Air-blow or flush fins with water as needed.
- 2) Confirm that no oil leaks from condenser. If a failure is found, replace condenser with a new one.

Tightening torque:

Refer to COMPONENT of General

Description

***<Ref. to AC-9, AIR CONDITIONING UNIT,
COMPONENT, General Description.>***

14. Receiver Drier S701283

A: REMOVAL S701283A18

- 1) Disconnect ground cable from battery.
- 2) Using refrigerant recovery system, discharge refrigerant. <Ref. to AC-18, OPERATION, Refrigerant Recovery Procedure.>
- 3) Disconnect pressure switch harness (A).
- 4) Disconnect pipe (B).
- 5) Loosen mounting bolts (C) to remove receiver drier.

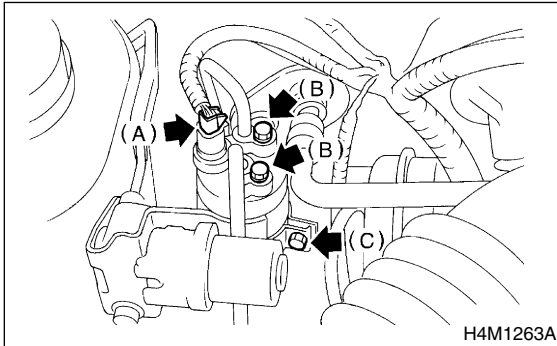

CAUTION:

The receiver drier contains a desiccant. After disconnecting receiver drier, plug it to avoid moisture.

If receiver drier is replaced, add appropriate amount of compressor oil to the compressor. <Ref. to AC-24, REPLACEMENT, Compressor Oil.>

B: INSTALLATION S701283A11

- 1) Install in the reverse order of removal.

CAUTION:

Replace O-rings with new ones, and apply compressor oil.

- 2) Charge refrigerant. <Ref. to AC-19, OPERATION, Refrigerant Charging Procedure.>

Tightening torque:

Refer to **COMPONENT** of **General Description**

<Ref. to AC-9, AIR CONDITIONING UNIT, COMPONENT, General Description.>

14. Receiver Drier S701283

A: REMOVAL S701283A18

- 1) Disconnect ground cable from battery.
- 2) Using refrigerant recovery system, discharge refrigerant. <Ref. to AC-18, OPERATION, Refrigerant Recovery Procedure.>
- 3) Disconnect pressure switch harness (A).
- 4) Disconnect pipe (B).
- 5) Loosen mounting bolts (C) to remove receiver drier.

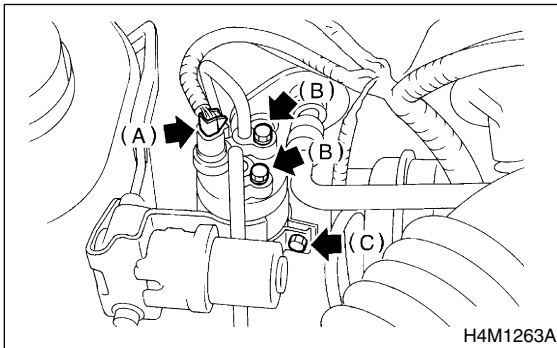

CAUTION:

The receiver drier contains a desiccant. After disconnecting receiver drier, plug it to avoid moisture.

If receiver drier is replaced, add appropriate amount of compressor oil to the compressor. <Ref. to AC-24, REPLACEMENT, Compressor Oil.>

B: INSTALLATION S701283A11

- 1) Install in the reverse order of removal.

CAUTION:

Replace O-rings with new ones, and apply compressor oil.

- 2) Charge refrigerant. <Ref. to AC-19, OPERATION, Refrigerant Charging Procedure.>

Tightening torque:

Refer to **COMPONENT** of **General Description**

<Ref. to AC-9, AIR CONDITIONING UNIT, COMPONENT, General Description.>

INTAKE UNIT

HVAC System (Heater, Ventilator and A/C)

15. Intake Unit S701632

A: REMOVAL S701632A18

- 1) Using refrigerant recovery system, discharge refrigerant. <Ref. to AC-18, OPERATION, Refrigerant Recovery Procedure.>
- 2) Disconnect ground cable from battery.
- 3) Remove bolts securing expansion valve and pipe in engine compartment.

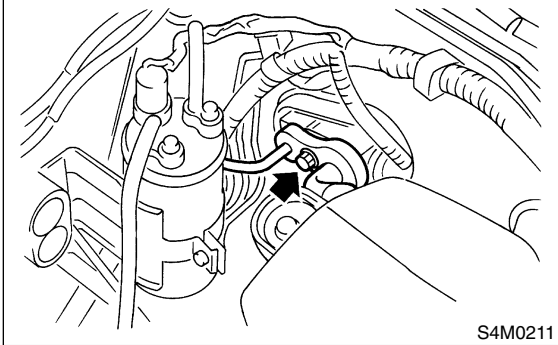

- 4) Remove instrument panel. <Ref. to EI-37, REMOVAL, Instrument Panel Assembly.>
- 5) Remove keyless unit and CRU unit.

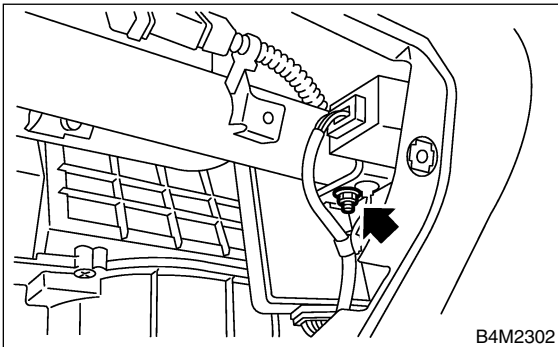

- 6) Disconnect sunroof connector.
- 7) Disconnect servo motor connector.

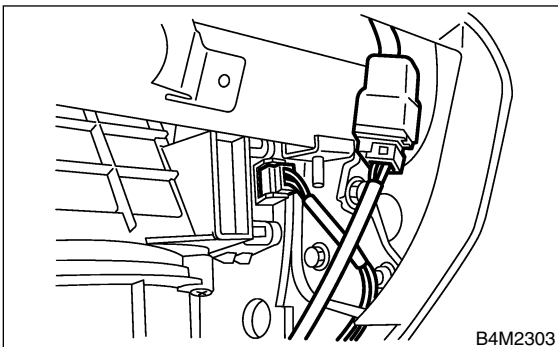

- 8) Disconnect heater blower power transistor connector.
- 9) Disconnect heater blower motor connector.

- 10) Disconnect in-vehicle temperature sensor connector.

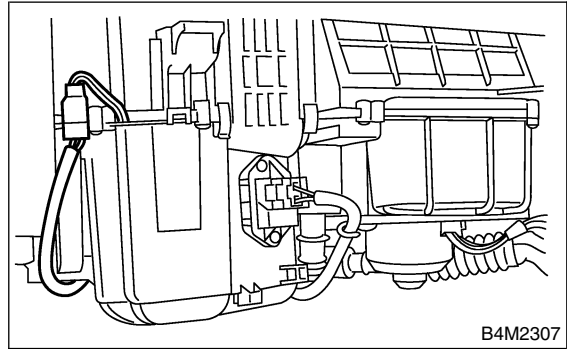

- 11) Remove bolts and nuts on the unit.

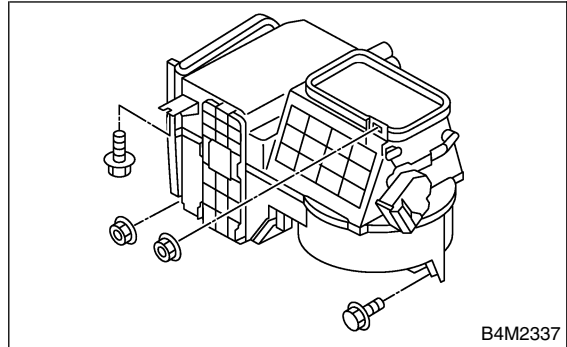

- 12) Disconnect drain hose.
- 13) Remove the unit.

B: INSTALLATION S701632A11

- 1) Install in the reverse order of removal.

CAUTION:
Replace O-rings with new ones, and apply compressor oil.

- 2) Charge refrigerant. <Ref. to AC-19, OPERATION, Refrigerant Charging Procedure.>

Tightening torque:

Refer to **COMPONENT** of **General Description**
<Ref. to AC-10, INTAKE UNIT WITH EVAPORATOR, COMPONENT, General Description.>

INTAKE UNIT

HVAC System (Heater, Ventilator and A/C)

C: DISASSEMBLY S701632A06

- 1) Remove resistor (A) and thermistor (B) from intake unit.
- 2) Remove screws and clips to separate intake unit.

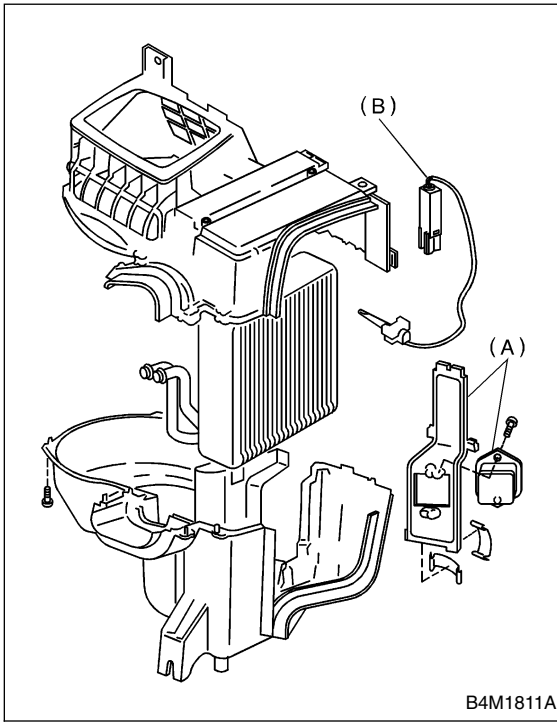

- 3) Remove expansion valve (A) from evaporator.

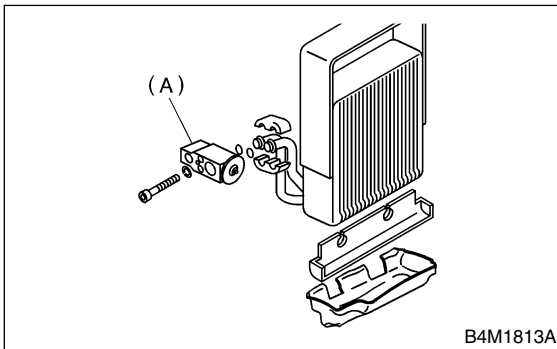

CAUTION:

If evaporator is replaced, add appropriate amount of compressor oil to evaporator. <Ref. to AC-24, REPLACEMENT, Compressor Oil.>

D: ASSEMBLY S701632A02

Assemble in the reverse order of disassembly.

CAUTION:
Replace O-rings with new ones, and then apply compressor oil.

INTAKE UNIT

HVAC System (Heater, Ventilator and A/C)

15. Intake Unit S701632

A: REMOVAL S701632A18

- 1) Using refrigerant recovery system, discharge refrigerant. <Ref. to AC-18, OPERATION, Refrigerant Recovery Procedure.>
- 2) Disconnect ground cable from battery.
- 3) Remove bolts securing expansion valve and pipe in engine compartment.

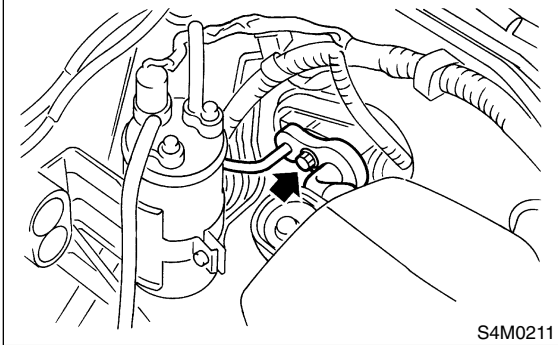

- 4) Remove instrument panel. <Ref. to EI-37, REMOVAL, Instrument Panel Assembly.>
- 5) Remove keyless unit and CRU unit.

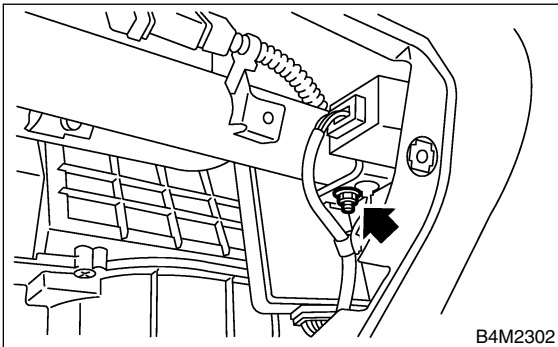

- 6) Disconnect sunroof connector.
- 7) Disconnect servo motor connector.

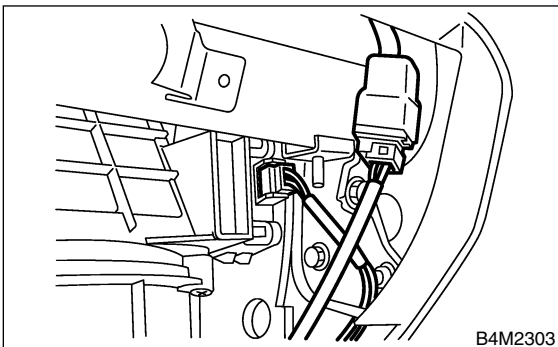

- 8) Disconnect heater blower power transistor connector.
- 9) Disconnect heater blower motor connector.

- 10) Disconnect in-vehicle temperature sensor connector.

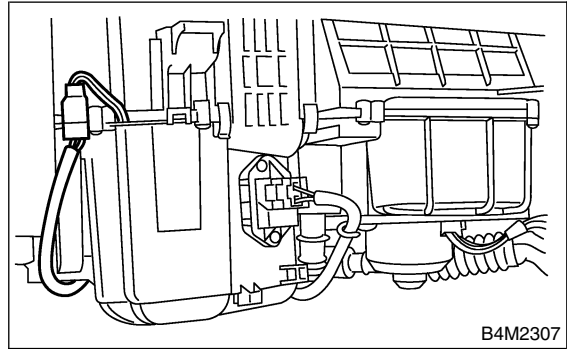

- 11) Remove bolts and nuts on the unit.

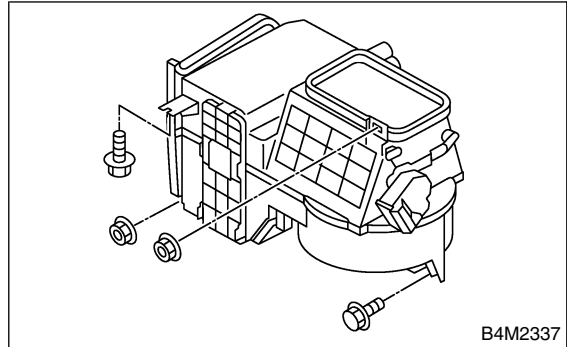

- 12) Disconnect drain hose.
- 13) Remove the unit.

B: INSTALLATION S701632A11

- 1) Install in the reverse order of removal.

CAUTION:
Replace O-rings with new ones, and apply compressor oil.

- 2) Charge refrigerant. <Ref. to AC-19, OPERATION, Refrigerant Charging Procedure.>

Tightening torque:

Refer to **COMPONENT** of **General Description**
<Ref. to AC-10, INTAKE UNIT WITH EVAPORATOR, COMPONENT, General Description.>

INTAKE UNIT

HVAC System (Heater, Ventilator and A/C)

C: DISASSEMBLY S701632A06

- 1) Remove resistor (A) and thermistor (B) from intake unit.
- 2) Remove screws and clips to separate intake unit.

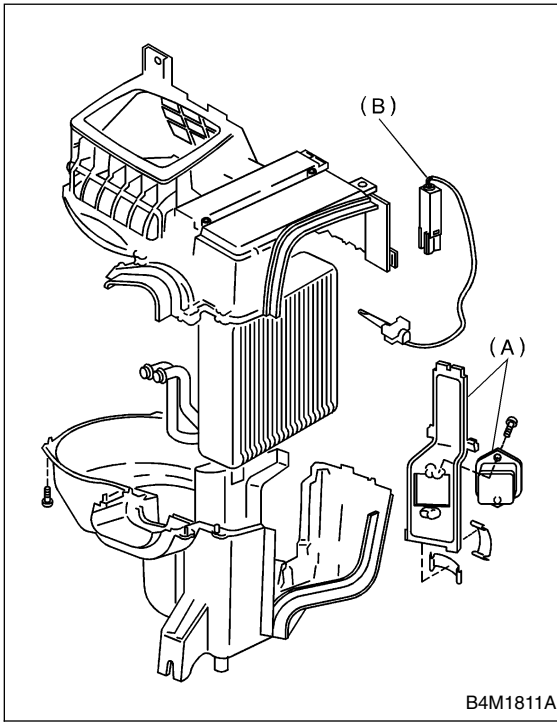

- 3) Remove expansion valve (A) from evaporator.

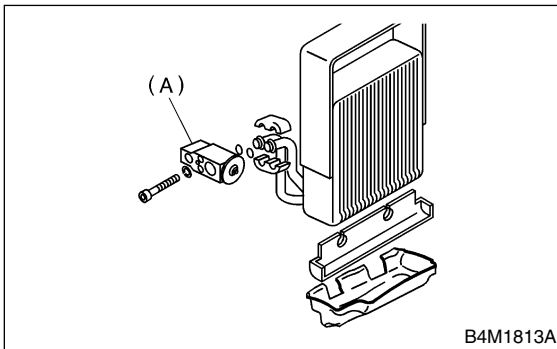

CAUTION:

If evaporator is replaced, add appropriate amount of compressor oil to evaporator. <Ref. to AC-24, REPLACEMENT, Compressor Oil.>

D: ASSEMBLY S701632A02

Assemble in the reverse order of disassembly.

CAUTION:
Replace O-rings with new ones, and then apply compressor oil.

FLEXIBLE HOSE

HVAC System (Heater, Ventilator and A/C)

16. Flexible Hose S701286

A: REMOVAL S701286A18

CAUTION:

- When disconnecting/connecting hoses, do not apply excessive force them. Confirm that no torsion and excessive tension exist after installing.
- Seal the disconnected hose with a plug or vinyl tape to prevent contamination from entering.

- 1) Disconnect ground cable from battery.
- 2) Using refrigerant recovery system, discharge refrigerant. <Ref. to AC-18, OPERATION, Refrigerant Recovery Procedure.>
- 3) Remove duct (A).

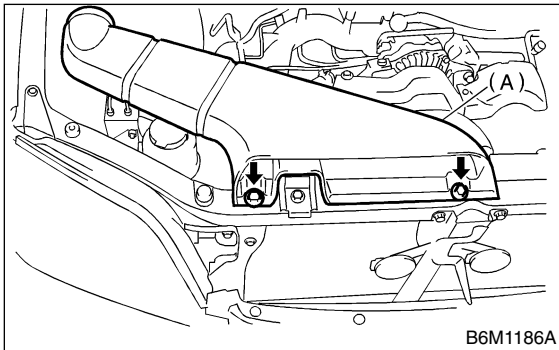

- 4) Remove hose attaching bolts (C).
- 5) Disconnect hose from evaporator unit.
- 6) Disconnect hose from compressor.
- 7) Remove low-pressure hose (A) from the vehicle.
- 8) Remove hose attaching bolts (D).
- 9) Disconnect hose from compressor.
- 10) Disconnect hose from condenser.

- 11) Disconnect high-pressure hose (B) from the vehicle.

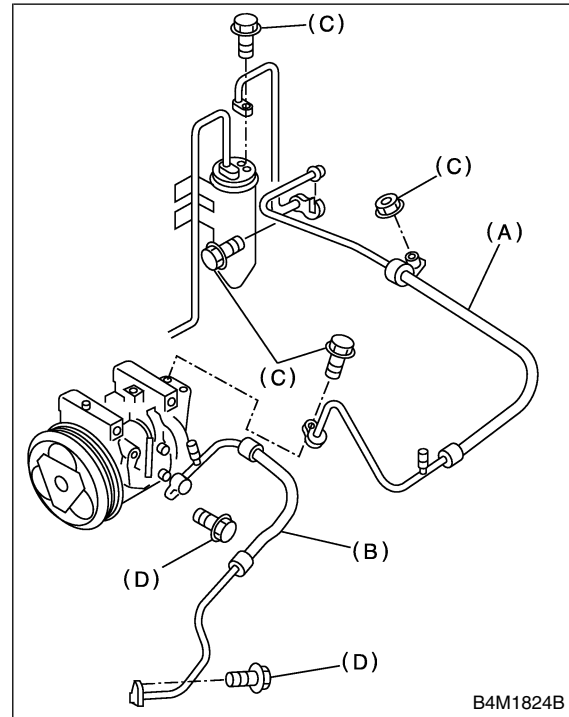

B: INSTALLATION S701286A11

CAUTION:

When disconnecting/connecting hoses, do not apply an excessive force them. Confirm that no torsion and excessive tension exists after installing.

Seal the disconnected hose with a plug or vinyl tape to prevent contamination from entering.

- 1) Install in the reverse order of removal.
- 2) Charge refrigerant. <Ref. to AC-19, OPERATION, Refrigerant Charging Procedure.>

Tightening torque:

Refer to **COMPONENT of General Description**

<Ref. to AC-9, AIR CONDITIONING UNIT, COMPONENT, General Description.>

C: INSPECTION S701286A10

NOTE:

If cracking, damage, or swelling is found on a hose, replace it with a new one.

FLEXIBLE HOSE

HVAC System (Heater, Ventilator and A/C)

16. Flexible Hose S701286

A: REMOVAL S701286A18

CAUTION:

- When disconnecting/connecting hoses, do not apply excessive force them. Confirm that no torsion and excessive tension exist after installing.
- Seal the disconnected hose with a plug or vinyl tape to prevent contamination from entering.

- 1) Disconnect ground cable from battery.
- 2) Using refrigerant recovery system, discharge refrigerant. <Ref. to AC-18, OPERATION, Refrigerant Recovery Procedure.>
- 3) Remove duct (A).

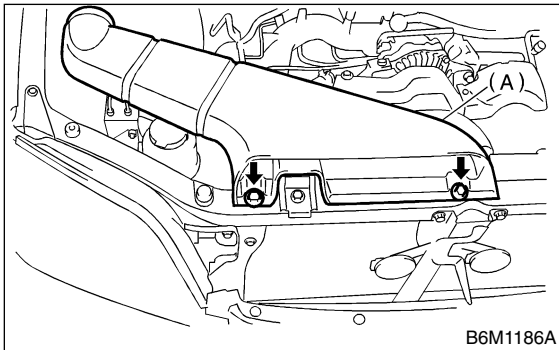

- 4) Remove hose attaching bolts (C).
- 5) Disconnect hose from evaporator unit.
- 6) Disconnect hose from compressor.
- 7) Remove low-pressure hose (A) from the vehicle.
- 8) Remove hose attaching bolts (D).
- 9) Disconnect hose from compressor.
- 10) Disconnect hose from condenser.

- 11) Disconnect high-pressure hose (B) from the vehicle.

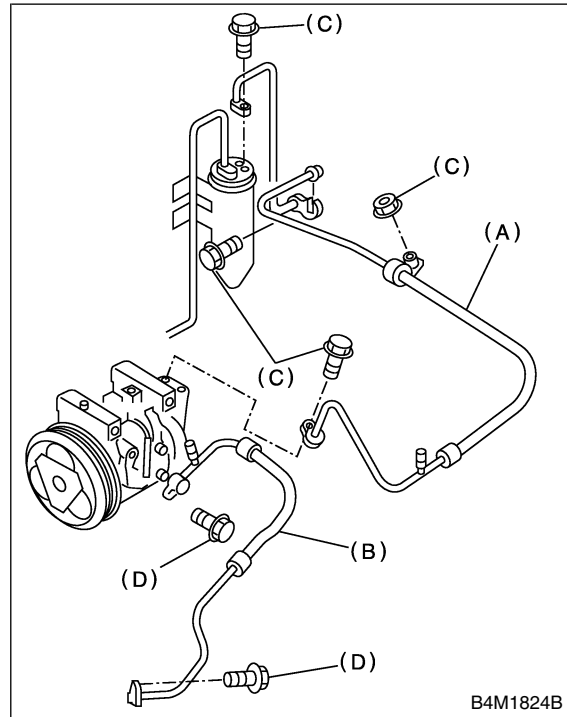

B: INSTALLATION S701286A11

CAUTION:

When disconnecting/connecting hoses, do not apply an excessive force them. Confirm that no torsion and excessive tension exists after installing.

Seal the disconnected hose with a plug or vinyl tape to prevent contamination from entering.

- 1) Install in the reverse order of removal.
- 2) Charge refrigerant. <Ref. to AC-19, OPERATION, Refrigerant Charging Procedure.>

Tightening torque:

Refer to **COMPONENT of General Description**

<Ref. to AC-9, AIR CONDITIONING UNIT, COMPONENT, General Description.>

C: INSPECTION S701286A10

NOTE:

If cracking, damage, or swelling is found on a hose, replace it with a new one.

17. Relay and Fuse S701287

A: LOCATION S701287A13

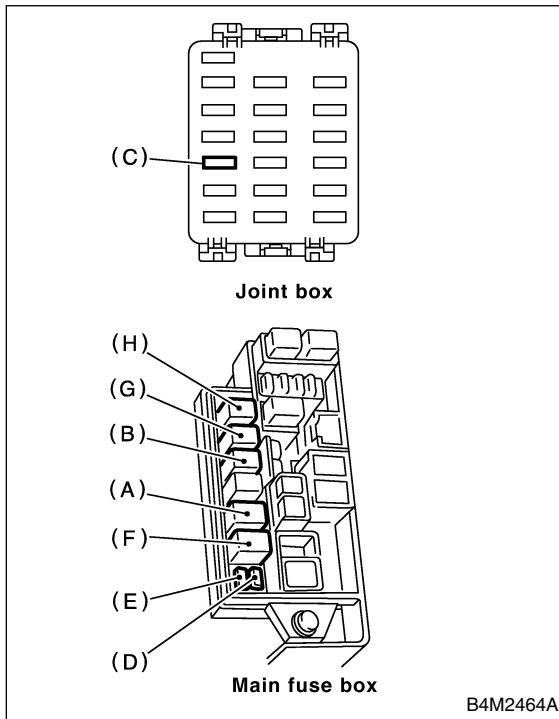

	4 cylinder engine model	6 cylinder engine model
Main fan relay	F	—
Sub fan relay	B	—
A/C relay	A	A
Main fan relay 1	—	F
Sub fan relay 1	—	G
Main fan relay 2	—	B
Sub fan relay 2	—	H
A/C fuse	C	C
Main fan fuse	E (20 A)	E (30 A)
Sub fan fuse	D (20 A)	D (30 A)

RELAY AND FUSE

HVAC System (Heater, Ventilator and A/C)

B: INSPECTION S701287A10

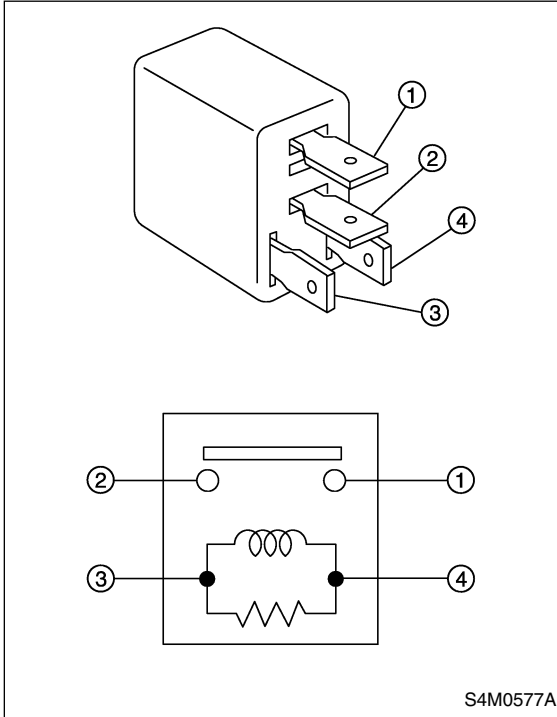

(3) — (4): Continuity exists.

(1) — (2): No continuity

While applying battery voltage to the cable between (3) and (4), check continuity between (1) and (2).

If no continuity exists, replace the relay with a new one.

17. Relay and Fuse S701287

A: LOCATION S701287A13

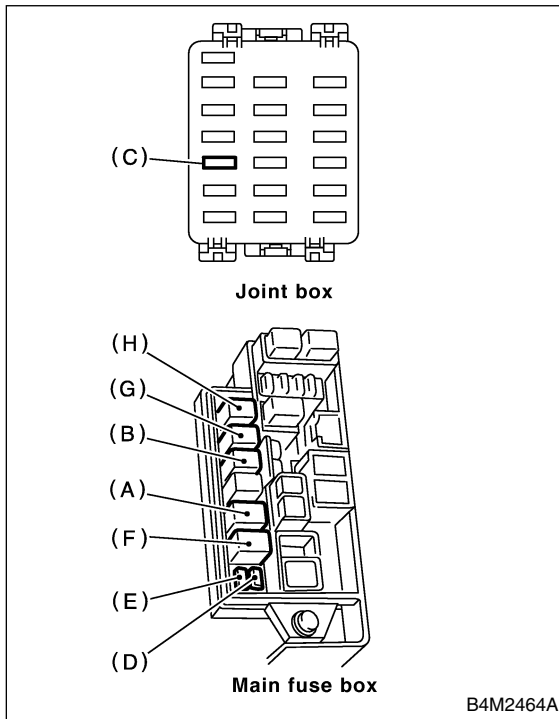

	4 cylinder engine model	6 cylinder engine model
Main fan relay	F	—
Sub fan relay	B	—
A/C relay	A	A
Main fan relay 1	—	F
Sub fan relay 1	—	G
Main fan relay 2	—	B
Sub fan relay 2	—	H
A/C fuse	C	C
Main fan fuse	E (20 A)	E (30 A)
Sub fan fuse	D (20 A)	D (30 A)

RELAY AND FUSE

HVAC System (Heater, Ventilator and A/C)

B: INSPECTION S701287A10

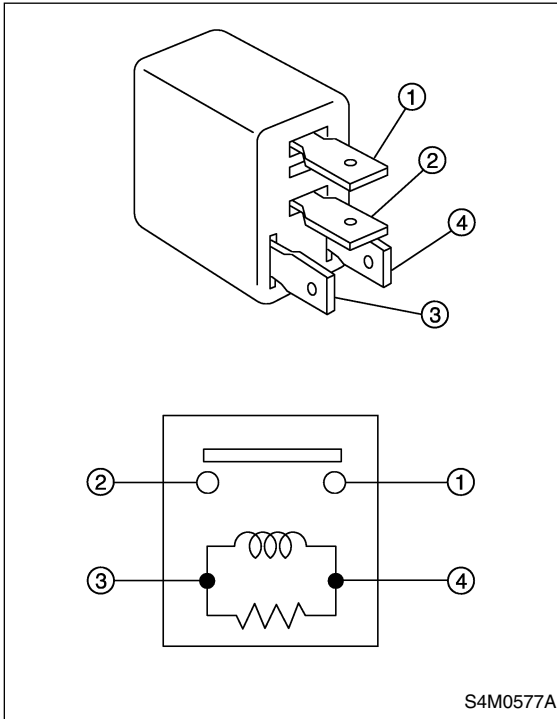

(3) — (4): Continuity exists.

(1) — (2): No continuity

While applying battery voltage to the cable between (3) and (4), check continuity between (1) and (2).

If no continuity exists, replace the relay with a new one.

PRESSURE SWITCH (DUAL SWITCH)

HVAC System (Heater, Ventilator and A/C)

18. Pressure Switch (Dual Switch)

S701555

A: INSPECTION

S701555A10

- 1) Connect the manifold gauge to the service valve on the high-pressure side.
- 2) Remove the pressure switch harness connector. Using a circuit tester, inspect the ON-OFF operation of the pressure switch.

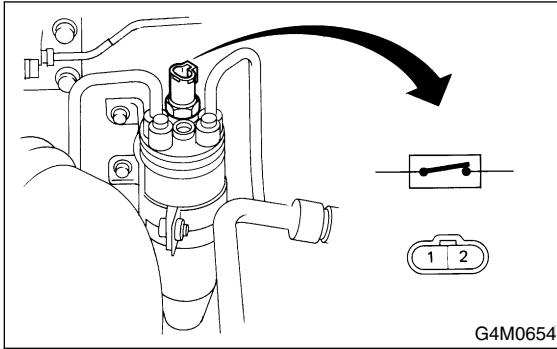

	Tester connection	Operation	Specified condition kPa (kg/cm ² , psi)
High and low pressure switch	1 — 2	Turns OFF.	Increasing to 2,942±196 (30±2, 427±28)
			Decreasing to 177±20 (1.8±0.2, 26±3)
		Turns ON.	Increasing to 216 (2.2, 31) or less
			Decreasing to 2,354±196 (24±2, 341±28)

PRESSURE SWITCH (DUAL SWITCH)

HVAC System (Heater, Ventilator and A/C)

18. Pressure Switch (Dual Switch)

S701555

A: INSPECTION

S701555A10

- 1) Connect the manifold gauge to the service valve on the high-pressure side.
- 2) Remove the pressure switch harness connector. Using a circuit tester, inspect the ON-OFF operation of the pressure switch.

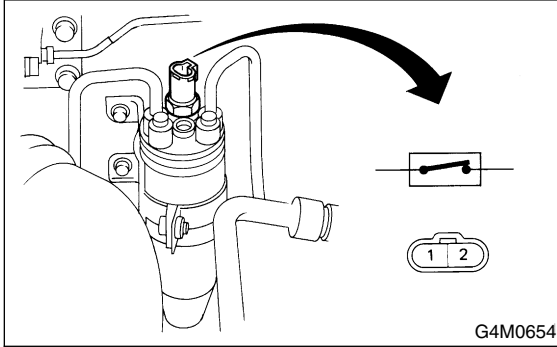

	Tester connection	Operation	Specified condition kPa (kg/cm ² , psi)
High and low pressure switch	1 — 2	Turns OFF.	Increasing to 2,942±196 (30±2, 427±28)
			Decreasing to 177±20 (1.8±0.2, 26±3)
		Turns ON.	Increasing to 216 (2.2, 31) or less
			Decreasing to 2,354±196 (24±2, 341±28)

PRESSURE SWITCH (TRIPLE SWITCH)

HVAC System (Heater, Ventilator and A/C)

19. Pressure Switch (Triple Switch)

S701633

A: INSPECTION

S701633A10

- 1) Connect the manifold gauge to the service manifold on the high-pressure side.
- 2) Remove the pressure switch harness connector. Using a circuit tester, inspect the ON-OFF operation of the pressure switch.

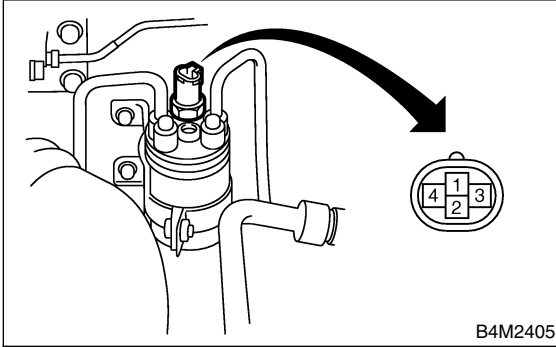

	Tester connection	Operation	Specified condition kPa (kg/cm ² , psi)
High and low pressure switch	1 — 2	Turns OFF.	Increasing to 2,940±196 (29.98±2.00, 426±28) Decreasing to 177±20 (1.8±0.2, 26±3)
		Turns ON.	Increasing to 216 or less (2.2, 31) Decreasing to 2,350±196 (23.97±2.00, 341±28)
Middle pressure switch	3 — 4	Turns OFF.	1,370±120 (13.97±1.22, 199±17)
		Turns ON.	1,770±100 (18.05±1.02, 257±15)

PRESSURE SWITCH (TRIPLE SWITCH)

HVAC System (Heater, Ventilator and A/C)

19. Pressure Switch (Triple Switch)

S701633

A: INSPECTION

S701633A10

- 1) Connect the manifold gauge to the service manifold on the high-pressure side.
- 2) Remove the pressure switch harness connector. Using a circuit tester, inspect the ON-OFF operation of the pressure switch.

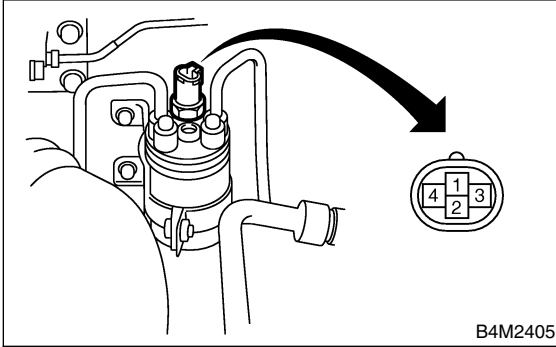

	Tester connection	Operation	Specified condition kPa (kg/cm ² , psi)
High and low pressure switch	1 — 2	Turns OFF.	Increasing to 2,940±196 (29.98±2.00, 426±28) Decreasing to 177±20 (1.8±0.2, 26±3)
		Turns ON.	Increasing to 216 or less (2.2, 31) Decreasing to 2,350±196 (23.97±2.00, 341±28)
Middle pressure switch	3 — 4	Turns OFF.	1,370±120 (13.97±1.22, 199±17)
		Turns ON.	1,770±100 (18.05±1.02, 257±15)

20. Ambient Sensor (Auto A/C)

S701289

A: REMOVAL S701289A18

- 1) Open front hood.
- 2) Disconnect ground cable from battery.
- 3) Disconnect ambient sensor connector.
- 4) Remove ambient sensor from radiator lower panel.

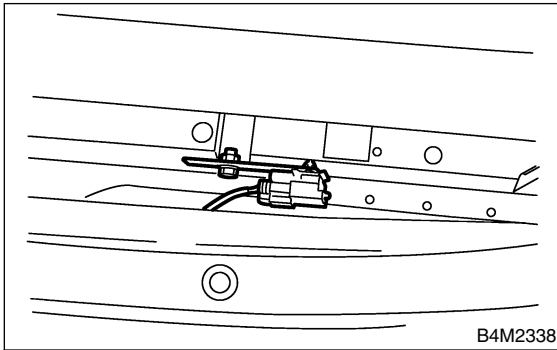

B: INSTALLATION S701289A11

Install in the reverse order of removal.

C: INSPECTION S701289A10

<Ref. to AC-26, TROUBLE CODE 21 OR -21 (AMBIENT SENSOR), Diagnostic Procedure with Trouble Code.>

20. Ambient Sensor (Auto A/C)

S701289

A: REMOVAL S701289A18

- 1) Open front hood.
- 2) Disconnect ground cable from battery.
- 3) Disconnect ambient sensor connector.
- 4) Remove ambient sensor from radiator lower panel.

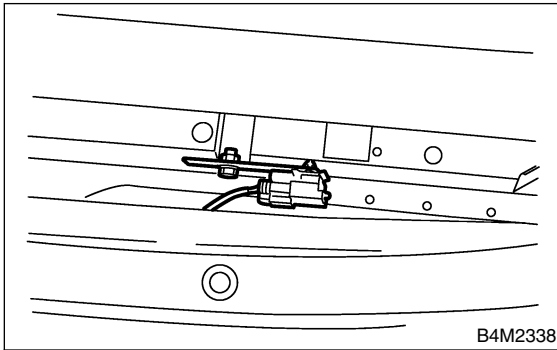

B: INSTALLATION S701289A11

Install in the reverse order of removal.

C: INSPECTION S701289A10

<Ref. to AC-26, TROUBLE CODE 21 OR -21 (AMBIENT SENSOR), Diagnostic Procedure with Trouble Code.>

SUN-LOAD SENSOR (AUTO A/C)

HVAC System (Heater, Ventilator and A/C)

21. Sun-load Sensor (Auto A/C)

S701279

A: REMOVAL S701279A18

- 1) Disconnect ground cable from battery.
- 2) Insert a slot-type screwdriver to remove sun-load sensor.

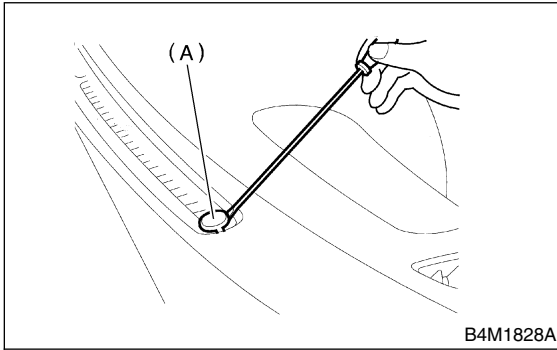

- 3) Disconnect sunload sensor connector.

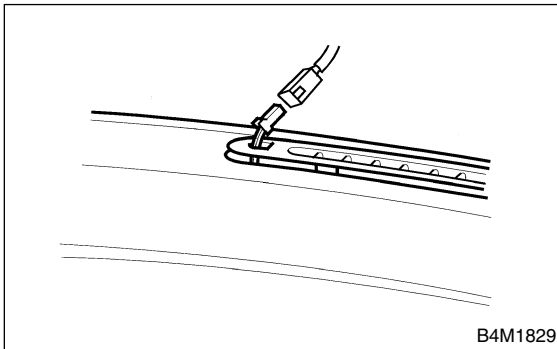

CAUTION:

Be careful not to damage sensors and interior trims when removing them.

B: INSTALLATION S701279A11

Install in the reverse order of removal.

C: INSPECTION S701279A10

<Ref. to AC-32, TROUBLE CODE 25 OR -25 (SUNLOAD SENSOR), Diagnostic Procedure with Trouble Code.>

SUN-LOAD SENSOR (AUTO A/C)

HVAC System (Heater, Ventilator and A/C)

21. Sun-load Sensor (Auto A/C)

S701279

A: REMOVAL S701279A18

- 1) Disconnect ground cable from battery.
- 2) Insert a slot-type screwdriver to remove sun-load sensor.

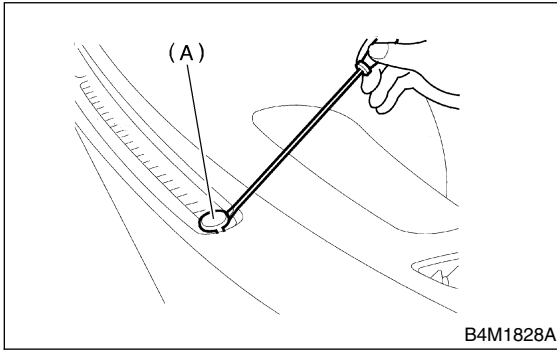

- 3) Disconnect sunload sensor connector.

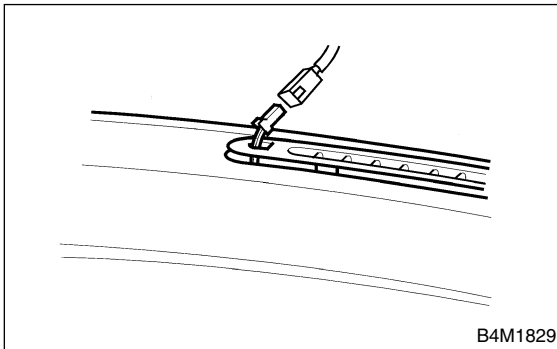

CAUTION:

Be careful not to damage sensors and interior trims when removing them.

B: INSTALLATION S701279A11

Install in the reverse order of removal.

C: INSPECTION S701279A10

<Ref. to AC-32, TROUBLE CODE 25 OR -25 (SUNLOAD SENSOR), Diagnostic Procedure with Trouble Code.>

22. Air Vent Grille S701284

A: REMOVAL S701284A18

1. AIR VENT GRILLE DRIVER SIDE S701284A1801

- 1) Disconnect ground cable from battery.
- 2) Set tilt steering to the lowest position.
- 3) Disconnect each electrical connector to remove front cover (A) and switch panel (B).
- 4) Loosen screw (C) to remove center panel (D).
- 5) Remove meter visor (E).

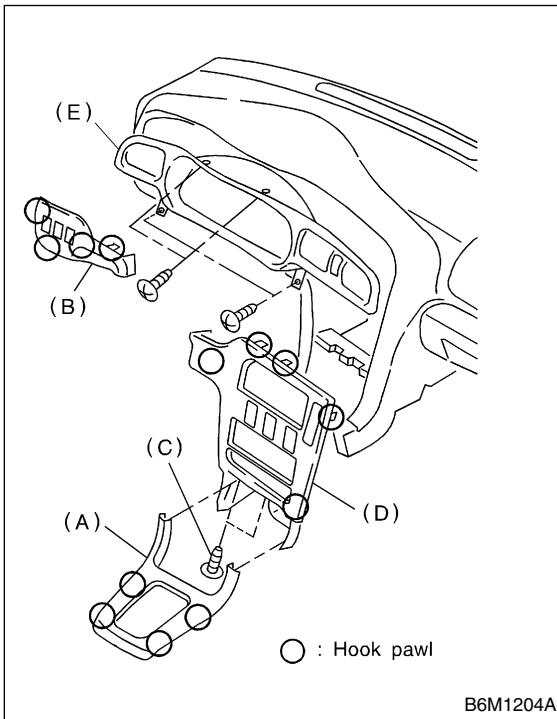

- 6) Loosen screws to remove grille.

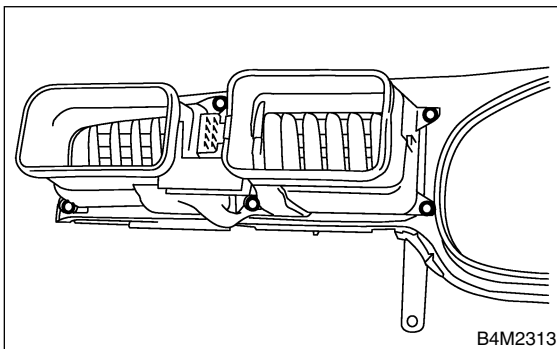

2. AIR VENT GRILLE PASSENGER SIDE S701284A1802

- 1) Remove grille using slot-type screwdriver.

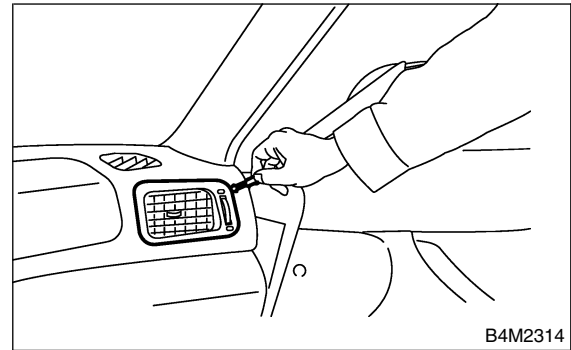

CAUTION:
Wrap screwdriver with vinyl tape to prevent damage to interior parts.

B: INSTALLATION S701284A11

Install in the reverse order of removal.

C: INSPECTION S701284A10

The direction and amount of air should be adjusted smoothly.
The adjustment should be kept in each position.

22. Air Vent Grille S701284

A: REMOVAL S701284A18

1. AIR VENT GRILLE DRIVER SIDE S701284A1801

- 1) Disconnect ground cable from battery.
- 2) Set tilt steering to the lowest position.
- 3) Disconnect each electrical connector to remove front cover (A) and switch panel (B).
- 4) Loosen screw (C) to remove center panel (D).
- 5) Remove meter visor (E).

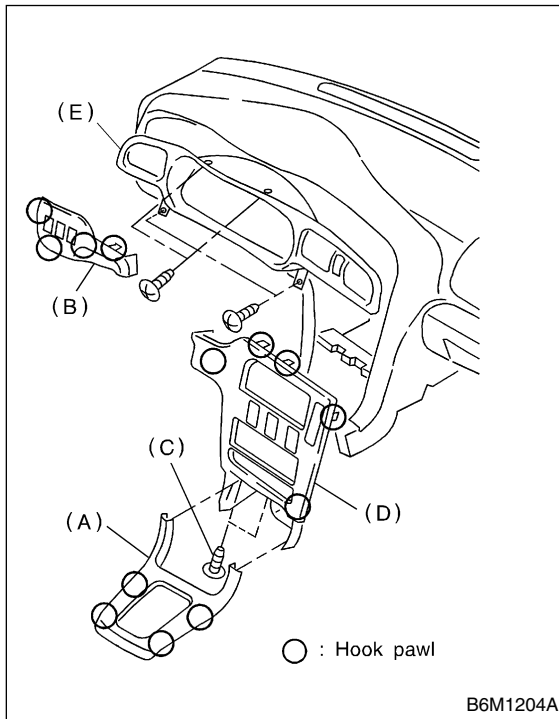

- 6) Loosen screws to remove grille.

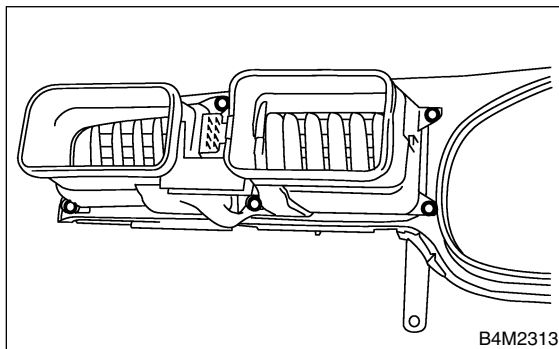

2. AIR VENT GRILLE PASSENGER SIDE S701284A1802

- 1) Remove grille using slot-type screwdriver.

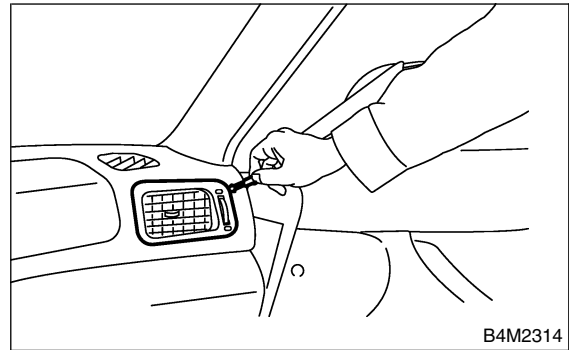

CAUTION:
Wrap screwdriver with vinyl tape to prevent damage to interior parts.

B: INSTALLATION S701284A11

Install in the reverse order of removal.

C: INSPECTION S701284A10

The direction and amount of air should be adjusted smoothly.
The adjustment should be kept in each position.

HEATER DUCT

HVAC System (Heater, Ventilator and A/C)

23. Heater Duct S701556

A: REMOVAL S701556A18

- 1) Remove heater unit. <Ref. to AC-25, REMOVAL, Heater Unit.>
- 2) Remove front seat. <Ref. to SE-7, REMOVAL, Front Seat.>
- 3) Remove front side sill cover.
- 4) Pull off floor mat to remove heater duct.

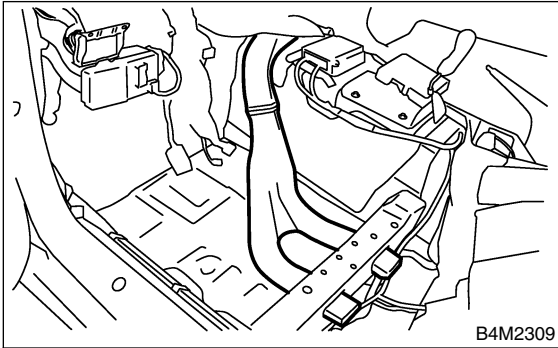

B: INSTALLATION S701556A11

Install in the reverse order of removal.

HEATER DUCT

HVAC System (Heater, Ventilator and A/C)

23. Heater Duct S701556

A: REMOVAL S701556A18

- 1) Remove heater unit. <Ref. to AC-25, REMOVAL, Heater Unit.>
- 2) Remove front seat. <Ref. to SE-7, REMOVAL, Front Seat.>
- 3) Remove front side sill cover.
- 4) Pull off floor mat to remove heater duct.

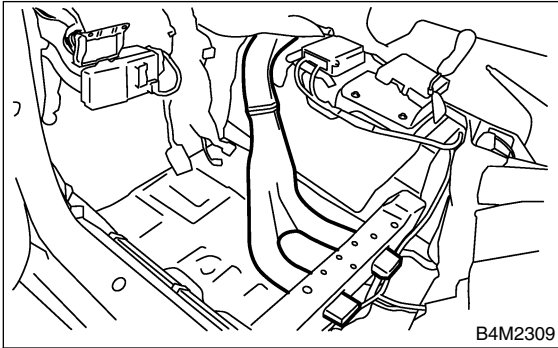

B: INSTALLATION S701556A11

Install in the reverse order of removal.

24. Heater Vent Duct S701557

A: REMOVAL S701557A18

- 1) Remove instrument panel. <Ref. to EI-37, REMOVAL, Instrument Panel Assembly.>
- 2) Remove nine screws.
- 3) Remove heater vent duct.

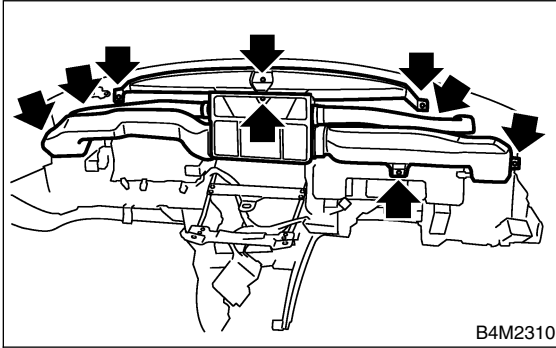

B: INSTALLATION S701557A11

Install in the reverse order of removal.

24. Heater Vent Duct S701557

A: REMOVAL S701557A18

- 1) Remove instrument panel. <Ref. to EI-37, REMOVAL, Instrument Panel Assembly.>
- 2) Remove nine screws.
- 3) Remove heater vent duct.

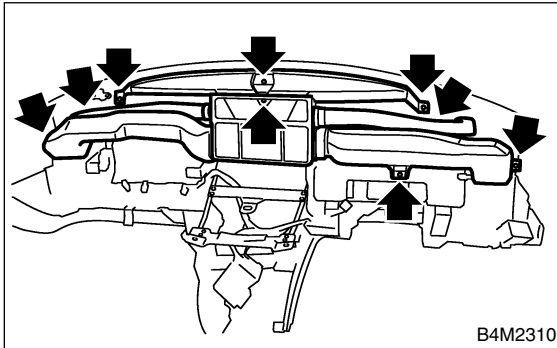

B: INSTALLATION S701557A11

Install in the reverse order of removal.

GENERAL DIAGNOSTICS

HVAC System (Heater, Ventilator and A/C)

25. General Diagnostics S701278

A: INSPECTION S701278A10

Symptom		Repair order
Blower motor	Doesn't move.	Fuse
		Blower motor relay
		Blower motor
		Blower motor resister
		Blower switch
	Wire harness	
	Strange noise.	Blower motor
Compressor	Doesn't move.	Refrigerant
		Fuse
		Air conditioning relay
		Magnet clutch
		Compressor
		Pressure switch
		A/C switch
		Blower switch
	Wire harness	
		Strange noise
		Magnet clutch
		Compressor
Cold air not emitted.		Refrigerant
		V-Belt
		Magnet clutch
		Compressor
		Pressure switch
		A/C switch
		Blower switch
		Wire harness
		Heater duct
		Heater vent duct
Warm air not emitted.		Engine coolant
		Blower switch
		Heater core
Temperature of air from vents does not change.		Engine coolant
		Mode actuator
		Wire harness
Unable to switch blow vents.		Mode actuator
		Air flow switch
		Wire harness
Unable to switch suction vents.		Air inlet select switch
		FRESH/RECIRC actuator
		Wire harness

GENERAL DIAGNOSTICS

HVAC System (Heater, Ventilator and A/C)

25. General Diagnostics S701278

A: INSPECTION S701278A10

Symptom		Repair order
Blower motor	Doesn't move.	Fuse
		Blower motor relay
		Blower motor
		Blower motor resister
		Blower switch
	Wire harness	
	Strange noise.	Blower motor
Compressor	Doesn't move.	Refrigerant
		Fuse
		Air conditioning relay
		Magnet clutch
		Compressor
		Pressure switch
		A/C switch
		Blower switch
	Wire harness	
		Strange noise
		Magnet clutch
		Compressor
Cold air not emitted.		Refrigerant
		V-Belt
		Magnet clutch
		Compressor
		Pressure switch
		A/C switch
		Blower switch
		Wire harness
		Heater duct
		Heater vent duct
Warm air not emitted.		Engine coolant
		Blower switch
		Heater core
Temperature of air from vents does not change.		Engine coolant
		Mode actuator
		Wire harness
Unable to switch blow vents.		Mode actuator
		Air flow switch
		Wire harness
Unable to switch suction vents.		Air inlet select switch
		FRESH/RECIRC actuator
		Wire harness

BASIC DIAGNOSTIC PROCEDURE

HVAC System (Auto A/C) (DIAGNOSTICS)

1. Basic Diagnostic Procedure S001501

A: PROCEDURE S001501E45

No.	Step	Check	Yes	No
1	START INSPECTIONS. 1) Perform pre-inspection. 2) Perform self-diagnosis. <Ref. to AC-12, SELF-DIAGNOSIS MODE, Diagnostics Chart for Diagnosis System.>	Does self-diagnosis operate?	Go to step 2.	<Ref. to AC-16, A/C AND/OR SELF-DIAGNOSIS SYSTEMS DO NOT OPERATE, Diagnostics for A/C System Failure.>
2	CHECK TROUBLE CODE. Check trouble code.	Is trouble code indicated?	<Ref. to AC-26, Diagnostic Procedure with Trouble Code.>	Go to step 3.
3	CHECK BLOWER MOTOR OPERATION. 1) Turn blower switch ON. 2) Check blower motor operation.	Is blower motor rotated?	Go to step 4.	<Ref. to AC-18, BLOWER MOTOR IS NOT ROTATED, Diagnostics for A/C System Failure.>
4	CHECK FRESH/RECIRC MODE. Change FRESH/RECIRC mode by pushing mode switch.	Is FRESH/RECIRC mode changed?	Go to step 5.	<Ref. to AC-20, FRESH/RECIRC IS NOT CHANGED, Diagnostics for A/C System Failure.>
5	CHECK COMPARTMENT TEMPERATURE. 1) Turn A/C switch ON. 2) Set temperature at 18°C (65°F) (MAX COOL). 3) Check compartment temperature changes.	Is the compartment temperature changed?	Go to step 6.	<Ref. to AC-22, COMPARTMENT TEMPERATURE IS NOT CHANGED OR A/C SYSTEM DOES NOT RESPOND QUICKLY, Diagnostics for A/C System Failure.>
6	CHECK A/C SYSTEM RESPONSE. Change the temperature setting, and check response of A/C system.	Does A/C system respond quickly?	A/C system is OK.	<Ref. to AC-22, COMPARTMENT TEMPERATURE IS NOT CHANGED OR A/C SYSTEM DOES NOT RESPOND QUICKLY, Diagnostics for A/C System Failure.>

BASIC DIAGNOSTIC PROCEDURE

HVAC System (Auto A/C) (DIAGNOSTICS)

1. Basic Diagnostic Procedure S001501

A: PROCEDURE S001501E45

No.	Step	Check	Yes	No
1	START INSPECTIONS. 1) Perform pre-inspection. 2) Perform self-diagnosis. <Ref. to AC-12, SELF-DIAGNOSIS MODE, Diagnostics Chart for Diagnosis System.>	Does self-diagnosis operate?	Go to step 2.	<Ref. to AC-16, A/C AND/OR SELF-DIAGNOSIS SYSTEMS DO NOT OPERATE, Diagnostics for A/C System Failure.>
2	CHECK TROUBLE CODE. Check trouble code.	Is trouble code indicated?	<Ref. to AC-26, Diagnostic Procedure with Trouble Code.>	Go to step 3.
3	CHECK BLOWER MOTOR OPERATION. 1) Turn blower switch ON. 2) Check blower motor operation.	Is blower motor rotated?	Go to step 4.	<Ref. to AC-18, BLOWER MOTOR IS NOT ROTATED, Diagnostics for A/C System Failure.>
4	CHECK FRESH/RECIRC MODE. Change FRESH/RECIRC mode by pushing mode switch.	Is FRESH/RECIRC mode changed?	Go to step 5.	<Ref. to AC-20, FRESH/RECIRC IS NOT CHANGED, Diagnostics for A/C System Failure.>
5	CHECK COMPARTMENT TEMPERATURE. 1) Turn A/C switch ON. 2) Set temperature at 18°C (65°F) (MAX COOL). 3) Check compartment temperature changes.	Is the compartment temperature changed?	Go to step 6.	<Ref. to AC-22, COMPARTMENT TEMPERATURE IS NOT CHANGED OR A/C SYSTEM DOES NOT RESPOND QUICKLY, Diagnostics for A/C System Failure.>
6	CHECK A/C SYSTEM RESPONSE. Change the temperature setting, and check response of A/C system.	Does A/C system respond quickly?	A/C system is OK.	<Ref. to AC-22, COMPARTMENT TEMPERATURE IS NOT CHANGED OR A/C SYSTEM DOES NOT RESPOND QUICKLY, Diagnostics for A/C System Failure.>

2. General Description S001001

A: CAUTION S001001A03

- 1) Never connect the battery in reverse polarity.
 - The auto A/C control module will be destroyed instantly.
- 2) Do not disconnect the battery cables while the engine is running.
 - A large counter electromotive force will be generated in the alternator, and this voltage may damage electronic parts such as A/C control module.
- 3) Before disconnecting the connectors of each sensor and the A/C control module, be sure to turn off the ignition switch.
 - Otherwise, the auto A/C control module may be damaged.
- 4) Every auto A/C-related part is a precision part. Do not drop them.
- 5) Airbag system wiring harness is routed near the A/C control panel (A/C control module) and junction box.

CAUTION:

- All airbag system wiring harness and connectors are colored yellow. Do not use electrical test equipment on these circuits.
- Be careful not to damage airbag system wiring harness when servicing the A/C control panel (A/C control module) and junction box.

B: INSPECTION S001001A10

Before performing diagnosis, check the following items which might affect engine problems.

1. BATTERY S001001A1001

- 1) Measure battery voltage and specific gravity of electrolyte.

Standard voltage: 12 V

Specific gravity: Above 1.260

- 2) Check the condition of the fuses for A/C, heater and other fuses.
- 3) Check the condition of the harnesses and harness connectors connection.

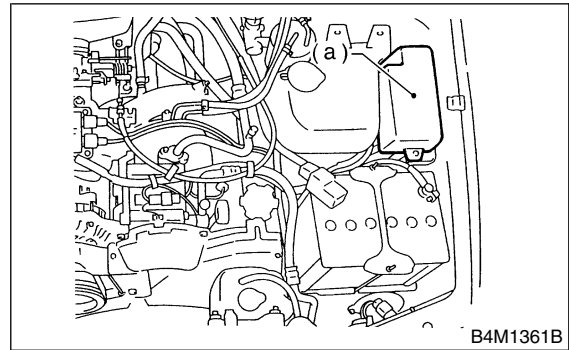

(a) Main fuse box

2. ASPIRATOR HOSE S001001A1002

- 1) Make sure that the aspirator hose is securely connected to the heater unit by inserting a hand from the driver's compartment and secure as necessary.
- 2) Turn ignition switch to ON.
- 3) Push "DEF" switch and then blower fan switch to turn the blower fan to maximum speed.

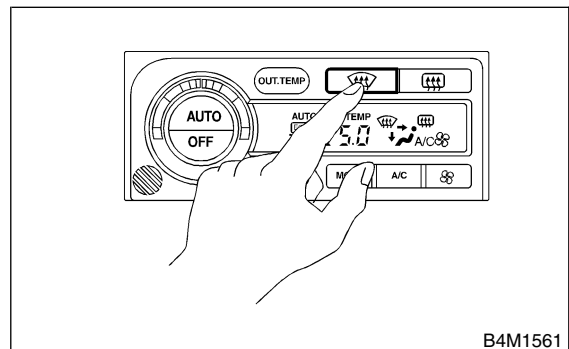

GENERAL DESCRIPTION

HVAC System (Auto A/C) (DIAGNOSTICS)

4) Firmly hold a thin thread (b) in front of the in-vehicle sensor suction port (a) for the auto A/C control unit and check that the thread moves towards the port indicating that air is being sucked into the port.

NOTE:

- Ensure the thread does not get sucked into the port.
- Hold the thread approximately 5 mm (0.20 in) away from the port when the suction force is not very strong.

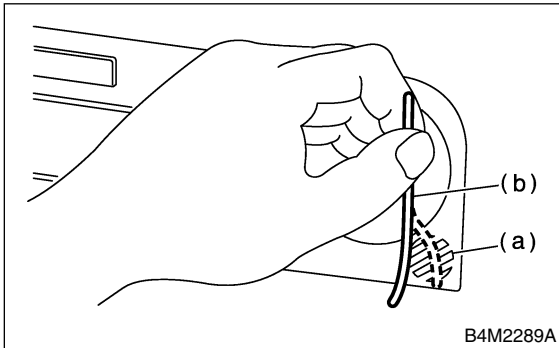

5) If the thread does not move at all, remove the auto A/C control unit <Ref. to AC-30, AUTO A/C, REMOVAL, Control Unit.> and check for improper connection of the aspirator hose (a) and auto A/C control unit and secure as necessary.

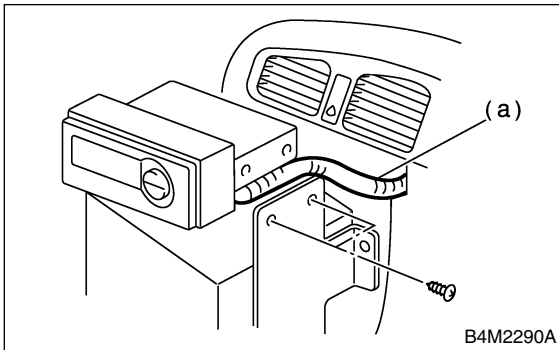

3. REFRIGERANT LINE S001001A1003

Check contact for refrigerant line (A).

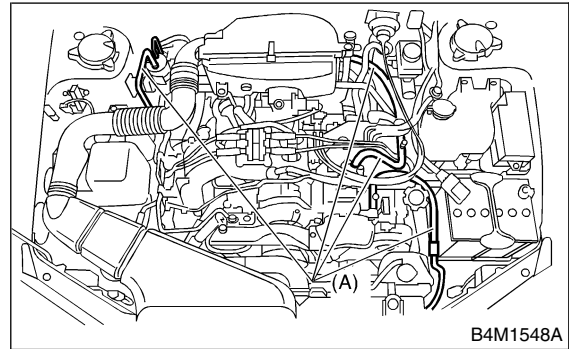

4. CONTROL LINKAGE S001001A1004

- 1) Check state of mode door control rod and linkage.
- 2) Check state of air mix door control rod and linkage.
- 3) Check state of intake door control rod and linkage.

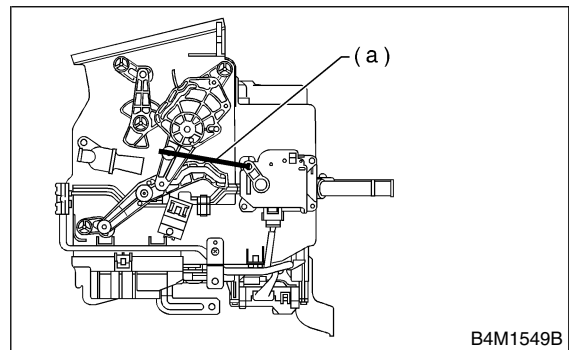

(a) Control rod

GENERAL DESCRIPTION

HVAC System (Auto A/C) (DIAGNOSTICS)

5. CONTROL SWITCHES S001001A1006

Start and warm up engine completely.

1) Inspection using switches.

No.	Point to check	Switch operation	Judgement standard
1	OFF switch	OFF switch "ON"	"SET" temperature display go out. <ul style="list-style-type: none"> ● Air flow → OFF ● Outlet → HEAT ● Inlet → FRESH ● Compressor → OFF
2	AUTO switch	A. AUTO switch "ON" B. Temp. control switch 18°C (65°F) (Max. Cold)	a. AUTO switch display illuminates. b. <ul style="list-style-type: none"> ● Outlet air → Cool ● Air flow → HI (AUTO) ● Outlet → VENT ● Inlet → AUTO ● Compressor → AUTO
		C. TEMP control switch is gradually set from 18°C (65°F) to 32°C (85°F).	c. Air and air outlet mode change as follows: <ul style="list-style-type: none"> ● Outlet air: Cool → Hot ● Air flow: AUTO ● Outlet: VENT → BI-LEVEL → HEAT ● Inlet: AUTO
		D. Temp. control switch 32°C (85°F) (Max. Hot)	d. Outlet air → Hot <ul style="list-style-type: none"> ● Air flow → HI (AUTO) ● Outlet → HEAT ● Inlet → FRESH (AUTO) ● Compressor → AUTO
3	DEF switch	A. DEF switch "ON" B. Temp. control switch 18 — 32°C (65 — 85°F)	a. DEF switch display illuminates. b. <ul style="list-style-type: none"> ● Outlet air temperature (AUTO control) ● Air flow (AUTO control) ● Outlet → DEF ● Inlet → FRESH ● Compressor → ON
4	FRESH/RECIRC switch	FRESH/RECIRC switch "ON"	Changes from RECIRC → FRESH, or FRESH → RECIRC.
5	MODE switch	MODE switch "ON"	Outlet changes from VENT → BI-LEVEL → HEAT → DEF/HEAT each time MODE switch is pushed.
6	FAN switch	FAN switch "ON"	Fan speed changes from LO → M1 → M2 → HI each time FAN switch is pushed.
7	OUT-TEMP switch	OUT-TEMP switch "ON"	Ambient temperature flashes on "set" temperature display, and "set" temperature appears.

2) Compressor operation inspection

No.	Point to check	Switch operation	Judgement standard	Remarks
1	Compressor	A. AUTO switch "ON" B. A/C switch "ON" C. DEF switch "ON"	a. Compressor ON b. Compressor ON c. Compressor ON	Compressor turns OFF several seconds after AUTO switch is turned ON.

3) Illumination control inspection

No.	Point to check	Switch operation	Judgement standard	Remarks
1	Illumination switch	Lighting switch "ON"	Illumination light illuminates and both switch light and "set" temperature display dim. <ul style="list-style-type: none"> ● Switch lights: OFF → Green light illuminates. ON → Green light illuminates. 	Green lights remain on although OFF and OUT-TEMP switches are ON.

2. General Description S001001

A: CAUTION S001001A03

- 1) Never connect the battery in reverse polarity.
 - The auto A/C control module will be destroyed instantly.
- 2) Do not disconnect the battery cables while the engine is running.
 - A large counter electromotive force will be generated in the alternator, and this voltage may damage electronic parts such as A/C control module.
- 3) Before disconnecting the connectors of each sensor and the A/C control module, be sure to turn off the ignition switch.
 - Otherwise, the auto A/C control module may be damaged.
- 4) Every auto A/C-related part is a precision part. Do not drop them.
- 5) Airbag system wiring harness is routed near the A/C control panel (A/C control module) and junction box.

CAUTION:

- All airbag system wiring harness and connectors are colored yellow. Do not use electrical test equipment on these circuits.
- Be careful not to damage airbag system wiring harness when servicing the A/C control panel (A/C control module) and junction box.

B: INSPECTION S001001A10

Before performing diagnosis, check the following items which might affect engine problems.

1. BATTERY S001001A1001

- 1) Measure battery voltage and specific gravity of electrolyte.

Standard voltage: 12 V

Specific gravity: Above 1.260

- 2) Check the condition of the fuses for A/C, heater and other fuses.
- 3) Check the condition of the harnesses and harness connectors connection.

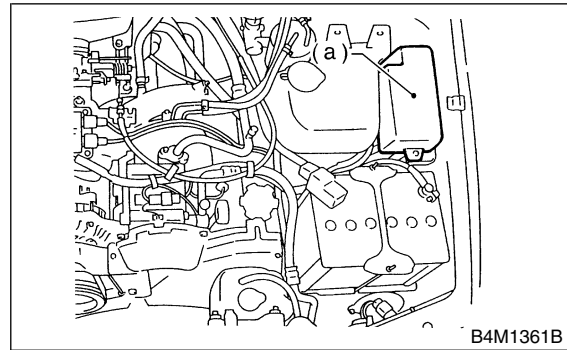

(a) Main fuse box

2. ASPIRATOR HOSE S001001A1002

- 1) Make sure that the aspirator hose is securely connected to the heater unit by inserting a hand from the driver's compartment and secure as necessary.
- 2) Turn ignition switch to ON.
- 3) Push "DEF" switch and then blower fan switch to turn the blower fan to maximum speed.

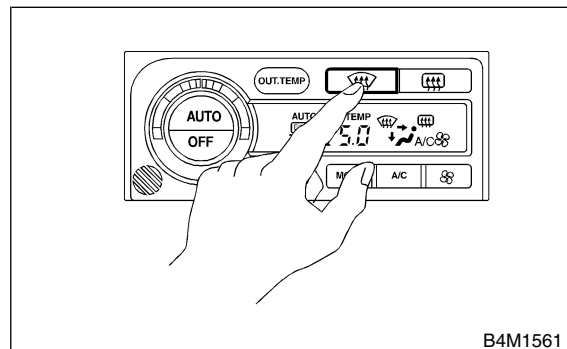

GENERAL DESCRIPTION

HVAC System (Auto A/C) (DIAGNOSTICS)

4) Firmly hold a thin thread (b) in front of the in-vehicle sensor suction port (a) for the auto A/C control unit and check that the thread moves towards the port indicating that air is being sucked into the port.

NOTE:

- Ensure the thread does not get sucked into the port.
- Hold the thread approximately 5 mm (0.20 in) away from the port when the suction force is not very strong.

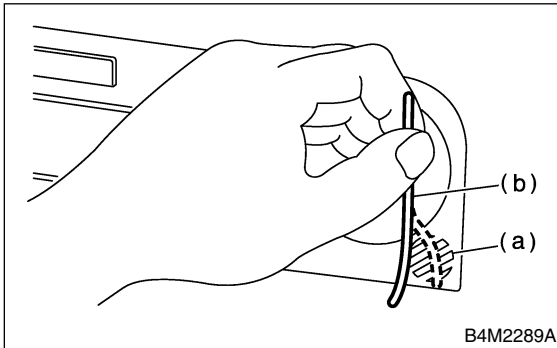

5) If the thread does not move at all, remove the auto A/C control unit <Ref. to AC-30, AUTO A/C, REMOVAL, Control Unit.> and check for improper connection of the aspirator hose (a) and auto A/C control unit and secure as necessary.

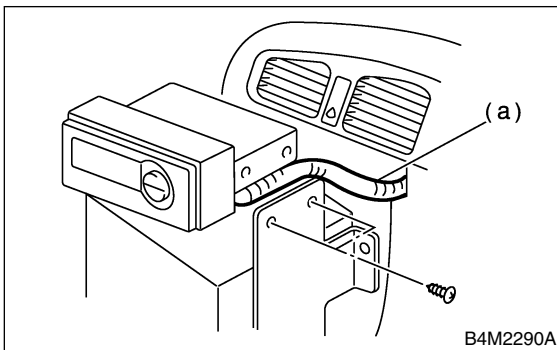

3. REFRIGERANT LINE S001001A1003

Check contact for refrigerant line (A).

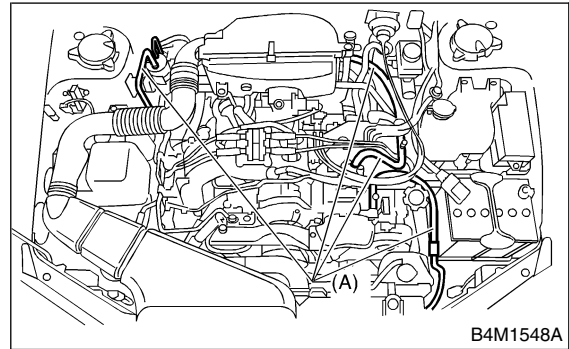

4. CONTROL LINKAGE S001001A1004

- 1) Check state of mode door control rod and linkage.
- 2) Check state of air mix door control rod and linkage.
- 3) Check state of intake door control rod and linkage.

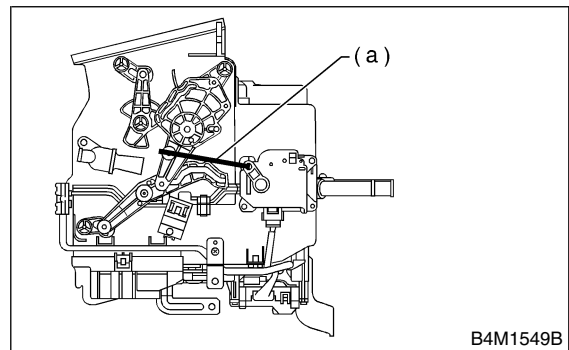

(a) Control rod

GENERAL DESCRIPTION

HVAC System (Auto A/C) (DIAGNOSTICS)

5. CONTROL SWITCHES S001001A1006

Start and warm up engine completely.

1) Inspection using switches.

No.	Point to check	Switch operation	Judgement standard
1	OFF switch	OFF switch "ON"	"SET" temperature display go out. <ul style="list-style-type: none"> ● Air flow → OFF ● Outlet → HEAT ● Inlet → FRESH ● Compressor → OFF
2	AUTO switch	A. AUTO switch "ON" B. Temp. control switch 18°C (65°F) (Max. Cold)	a. AUTO switch display illuminates. b. <ul style="list-style-type: none"> ● Outlet air → Cool ● Air flow → HI (AUTO) ● Outlet → VENT ● Inlet → AUTO ● Compressor → AUTO
		C. TEMP control switch is gradually set from 18°C (65°F) to 32°C (85°F).	c. Air and air outlet mode change as follows: <ul style="list-style-type: none"> ● Outlet air: Cool → Hot ● Air flow: AUTO ● Outlet: VENT → BI-LEVEL → HEAT ● Inlet: AUTO
		D. Temp. control switch 32°C (85°F) (Max. Hot)	d. Outlet air → Hot <ul style="list-style-type: none"> ● Air flow → HI (AUTO) ● Outlet → HEAT ● Inlet → FRESH (AUTO) ● Compressor → AUTO
3	DEF switch	A. DEF switch "ON" B. Temp. control switch 18 — 32°C (65 — 85°F)	a. DEF switch display illuminates. b. <ul style="list-style-type: none"> ● Outlet air temperature (AUTO control) ● Air flow (AUTO control) ● Outlet → DEF ● Inlet → FRESH ● Compressor → ON
4	FRESH/RECIRC switch	FRESH/RECIRC switch "ON"	Changes from RECIRC → FRESH, or FRESH → RECIRC.
5	MODE switch	MODE switch "ON"	Outlet changes from VENT → BI-LEVEL → HEAT → DEF/HEAT each time MODE switch is pushed.
6	FAN switch	FAN switch "ON"	Fan speed changes from LO → M1 → M2 → HI each time FAN switch is pushed.
7	OUT-TEMP switch	OUT-TEMP switch "ON"	Ambient temperature flashes on "set" temperature display, and "set" temperature appears.

2) Compressor operation inspection

No.	Point to check	Switch operation	Judgement standard	Remarks
1	Compressor	A. AUTO switch "ON" B. A/C switch "ON" C. DEF switch "ON"	a. Compressor ON b. Compressor ON c. Compressor ON	Compressor turns OFF several seconds after AUTO switch is turned ON.

3) Illumination control inspection

No.	Point to check	Switch operation	Judgement standard	Remarks
1	Illumination switch	Lighting switch "ON"	Illumination light illuminates and both switch light and "set" temperature display dim. <ul style="list-style-type: none"> ● Switch lights: OFF → Green light illuminates. ON → Green light illuminates. 	Green lights remain on although OFF and OUT-TEMP switches are ON.

ELECTRICAL COMPONENTS LOCATION

HVAC System (Auto A/C) (DIAGNOSTICS)

3. Electrical Components Location S001507

A: LOCATION S001507A13

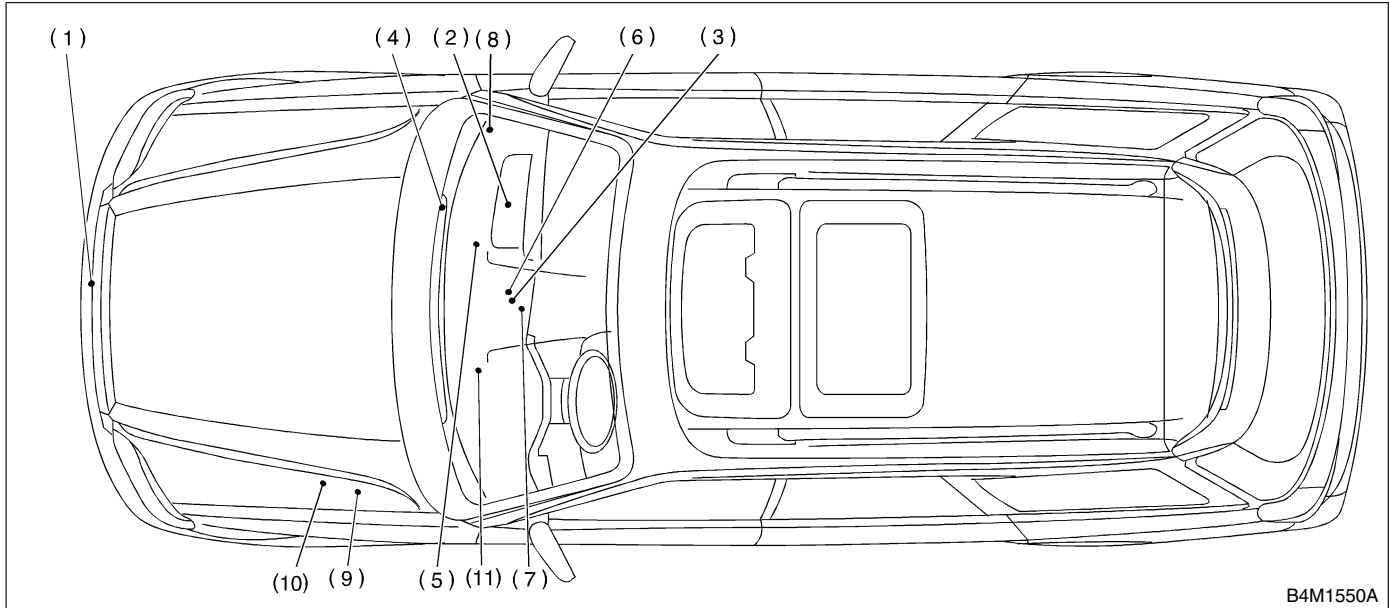

- | | | |
|-----------------------|-----------------------------|----------------------|
| (1) Ambient sensor | (5) Evaporator sensor | (9) A/C relay |
| (2) Power transistor | (6) Auto A/C control module | (10) A/C fuse |
| (3) In-vehicle sensor | (7) Air mix door motor | (11) Mode door motor |
| (4) Sunload sensor | (8) Intake door motor | |

ELECTRICAL COMPONENTS LOCATION

HVAC System (Auto A/C) (DIAGNOSTICS)

3. Electrical Components Location S001507

A: LOCATION S001507A13

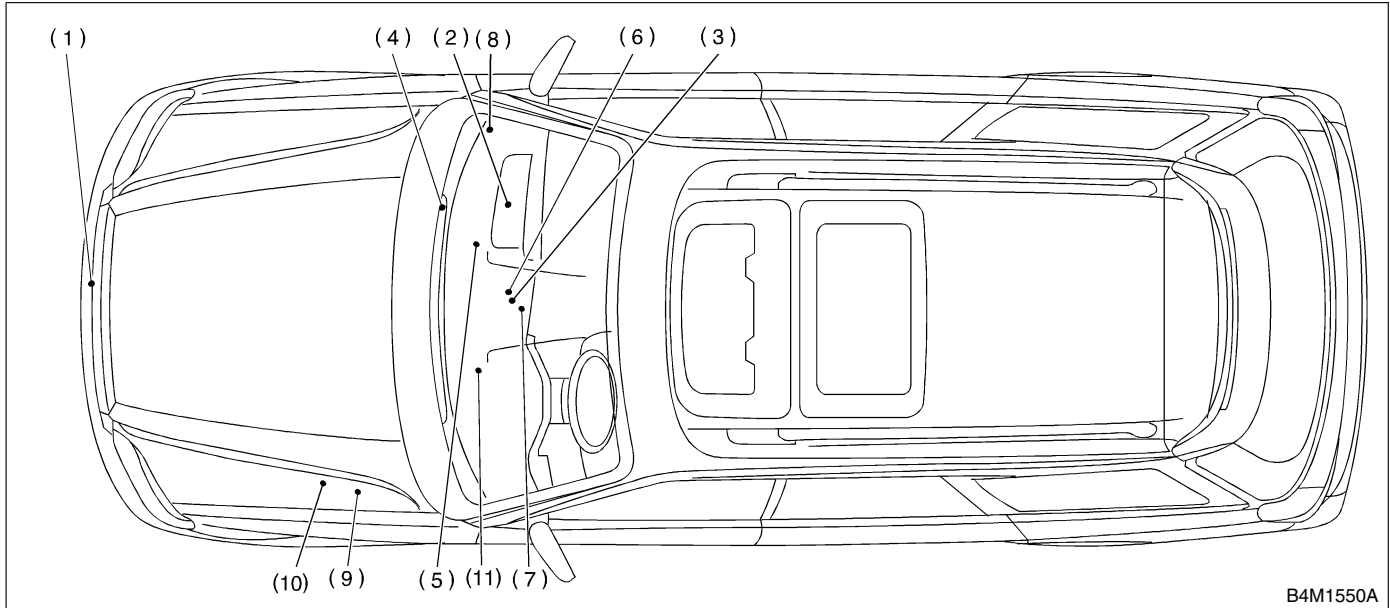

- | | | |
|-----------------------|-----------------------------|----------------------|
| (1) Ambient sensor | (5) Evaporator sensor | (9) A/C relay |
| (2) Power transistor | (6) Auto A/C control module | (10) A/C fuse |
| (3) In-vehicle sensor | (7) Air mix door motor | (11) Mode door motor |
| (4) Sunload sensor | (8) Intake door motor | |

A/C CONTROL MODULE I/O SIGNAL

HVAC System (Auto A/C) (DIAGNOSTICS)

4. A/C Control Module I/O Signal S001518

A: ELECTRICAL SPECIFICATION S001518A08

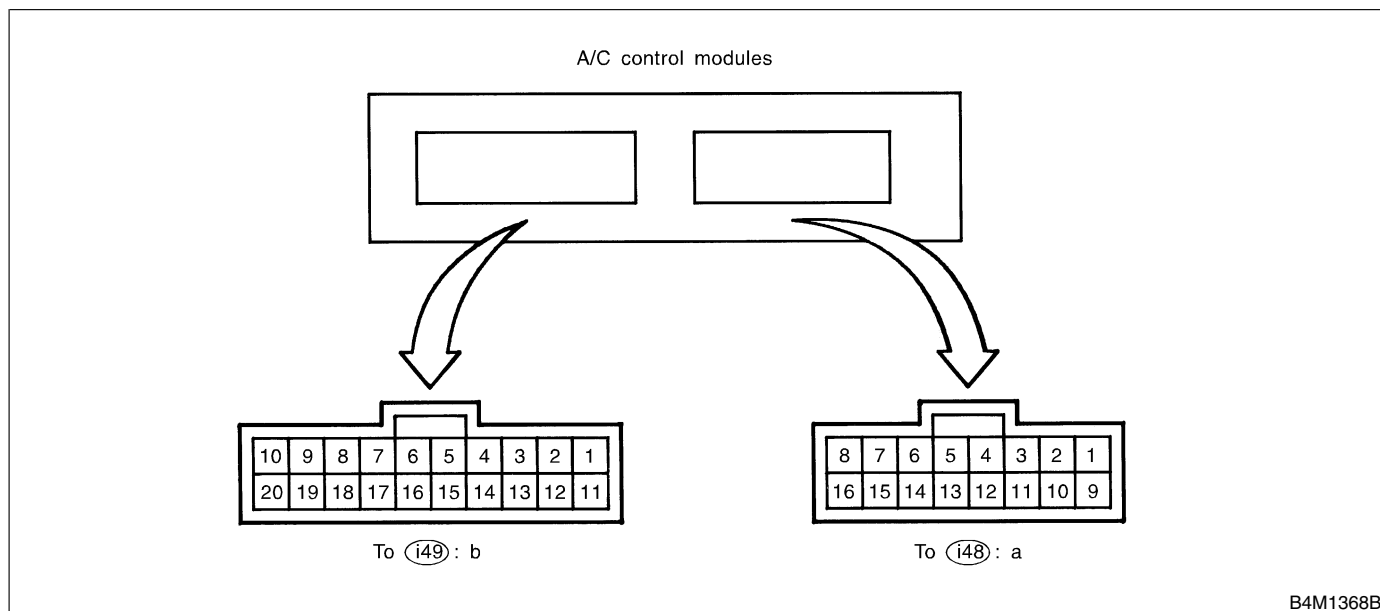

Content	Connector & Terminal No.	Signal (V)
BATT voltage (Memory back-up)	b1—b12	BATT voltage, 13 — 14 (engine running)
IGN power supply	a8—b12	Battery voltage (ignition switch ON), 13 — 14 (engine running)
ACC power supply (OFF: ignition in START or diagnosis system reset)	b2—b12	BATT voltage, 0 (engine cranking), BATT voltage (during engine starts)
A/C control module ground circuit	b12—body	0 (ignition switch ON) — circuit constantly grounded
Sensor ground circuit	b17—body	0 (ignition switch ON) — continuity exists
Ambient sensor	b6—b17	Approx. 3.3 (disconnect connector, and ignition switch ON)
Evaporator sensor	b7—b17	
Thermometer	b15—b12	
Sunload sensor	b16—b17	Approx. 4.2 (disconnect connector, and ignition switch ON)
Air mix door motor	a4—a3	BATT voltage (AUTO mode) positive “+” at terminal “a4” and negative “-” at “a3” [temperature set at 18°C (65°F)]; negative “-” at terminal “a4” and positive “+” at “a13” [temperature set at 32°C (85°F)]
Air mix door motor P.B.R.	a12—b17	Approx. 0.5 [temperature set at 18°C (65°F) in AUTO mode] Approx. 4.5 [temperature set at 32°C (85°F) in AUTO mode]
Mode actuator VENT	a5—b17	BATT voltage (ignition switch ON in MANUAL mode); positive “+” at terminal “a5” and negative “-” at “b17” (VENT); negative “-” at “a5” and positive “+” at “b17” (DEF)
Mode actuator DEF	a6—b17	BATT voltage (ignition switch ON in MANUAL mode) Approx. 4.5 (VENT); approx. 0.5 (DEF)
Intake door FRS voltage	a7—a15	BATT voltage (CIRC switch OFF)
Intake door CIRC voltage	a15—a7	BATT voltage (CIRC switch ON)
Blower fan relay	b14—body	BATT voltage (ignition switch ON)
A/C relay	b3—b12	0 (ignition and A/C switches ON) BATT voltage (A/C switch OFF)
Illumination control signal	b10—b20	BATT voltage (ignition and lighting switches ON)
Rear defogger	a13—b12	0 (IGN ON, R Def SW ON)

A/C CONTROL MODULE I/O SIGNAL

HVAC System (Auto A/C) (DIAGNOSTICS)

B: SCHEMATIC

S001518A21

1. AIR CONDITIONER AUTO A/C

S001518A2103

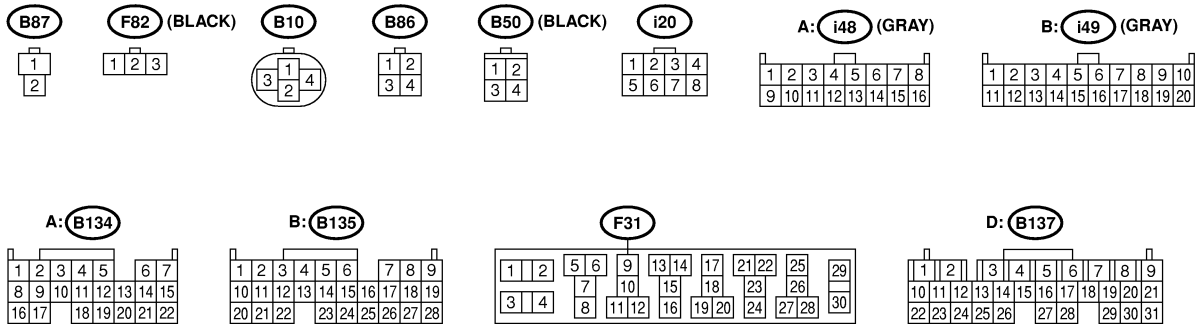
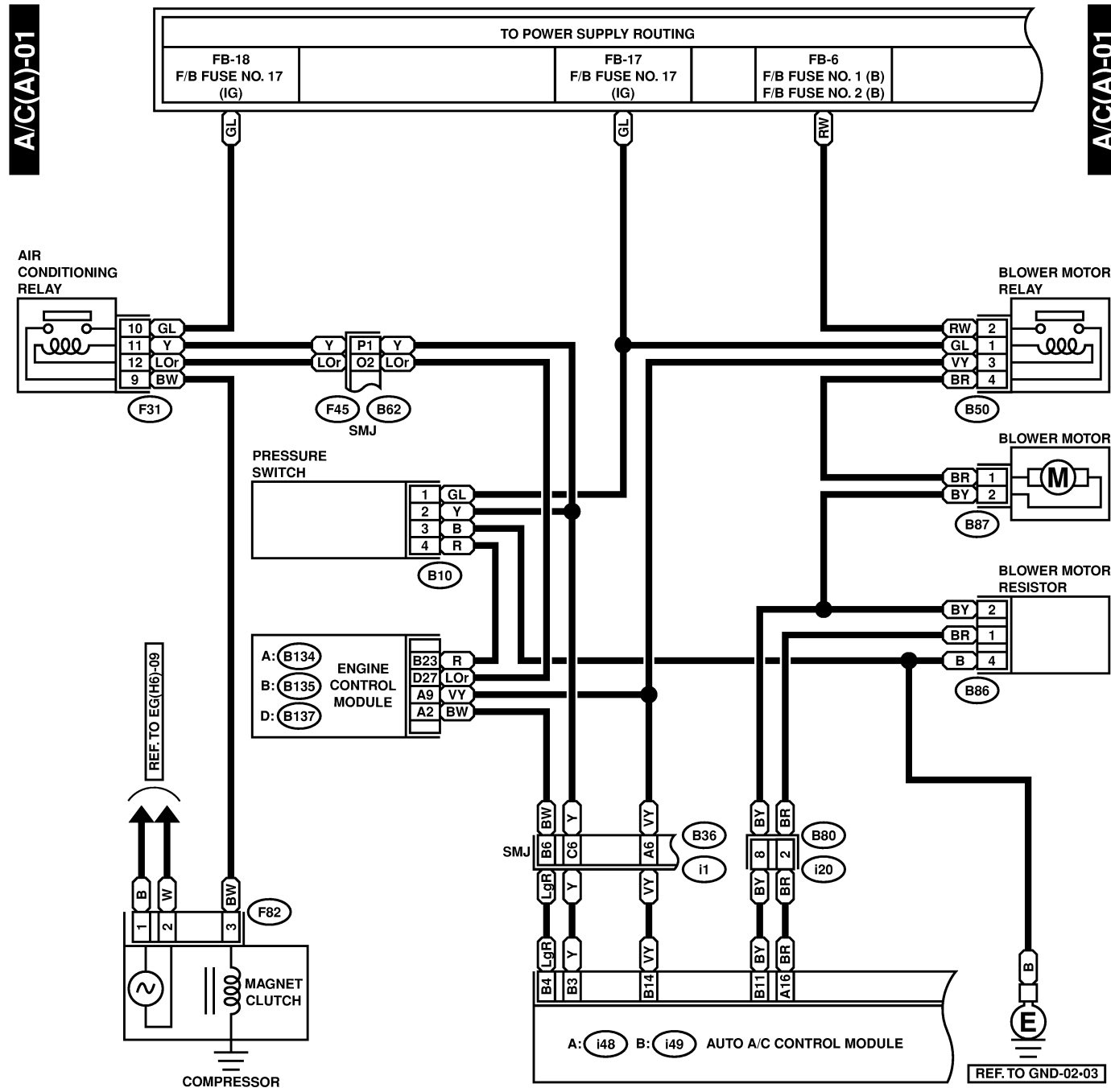

RELAY HOLDER (BLACK)

BU46-20A

A/C CONTROL MODULE I/O SIGNAL

HVAC System (Auto A/C) (DIAGNOSTICS)

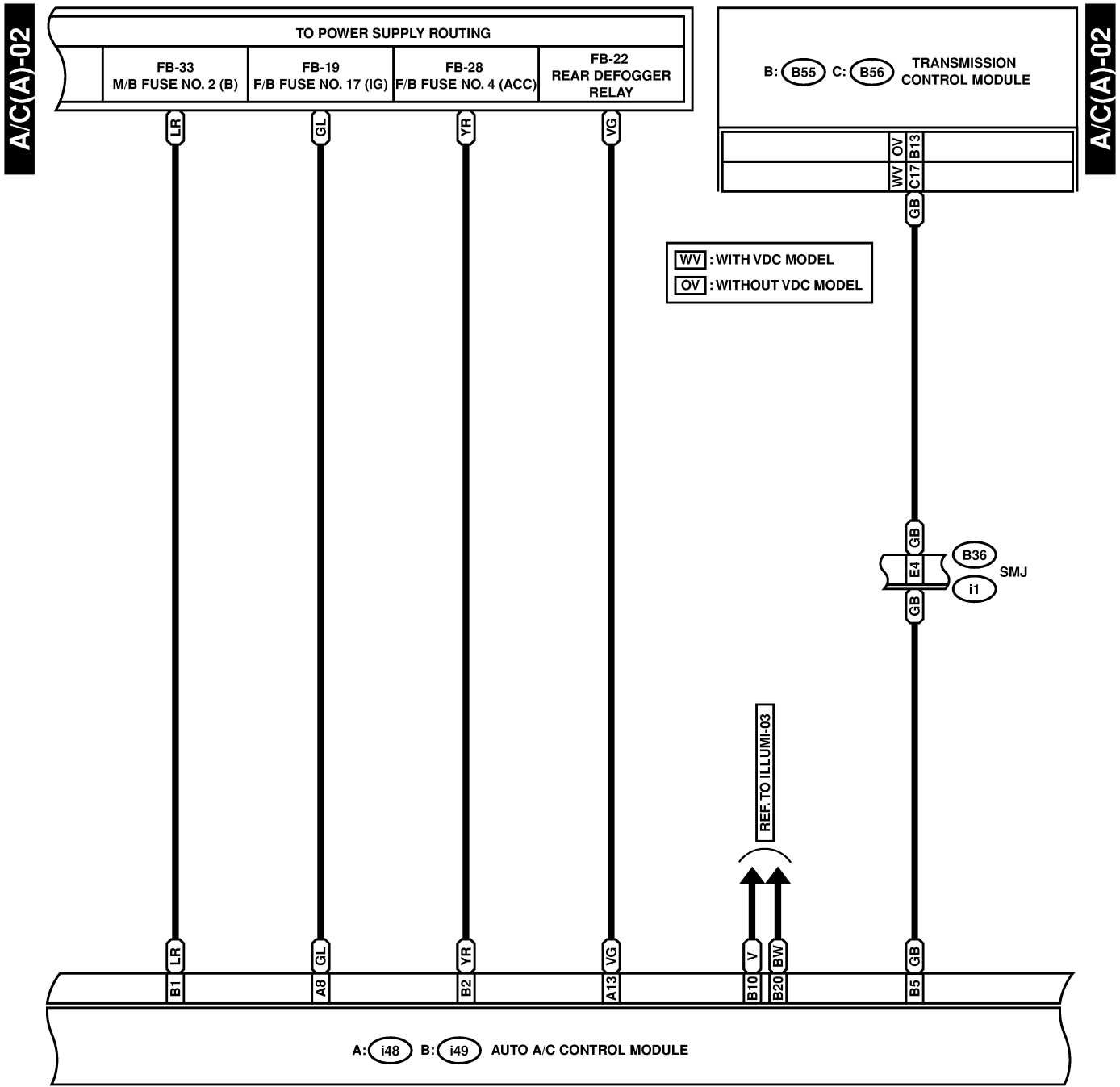

A: i48 (GRAY)

1	2	3	4	5	6	7	8
9	10	11	12	13	14	15	16

B: i49 (GRAY)

1	2	3	4	5	6	7	8	9	10
11	12	13	14	15	16	17	18	19	20

C: B56 (GREEN)

1	2	3	4	5	6	7	8	9
10	11	12	13	14	15	16	17	18
19	20	21				22	23	24

B: B55 (GRAY)

1	2	3	4	5	6	7	8	9
10	11	12	13	14	15	16	17	18
19	20	21				22	23	24

A/C CONTROL MODULE I/O SIGNAL

HVAC System (Auto A/C) (DIAGNOSTICS)

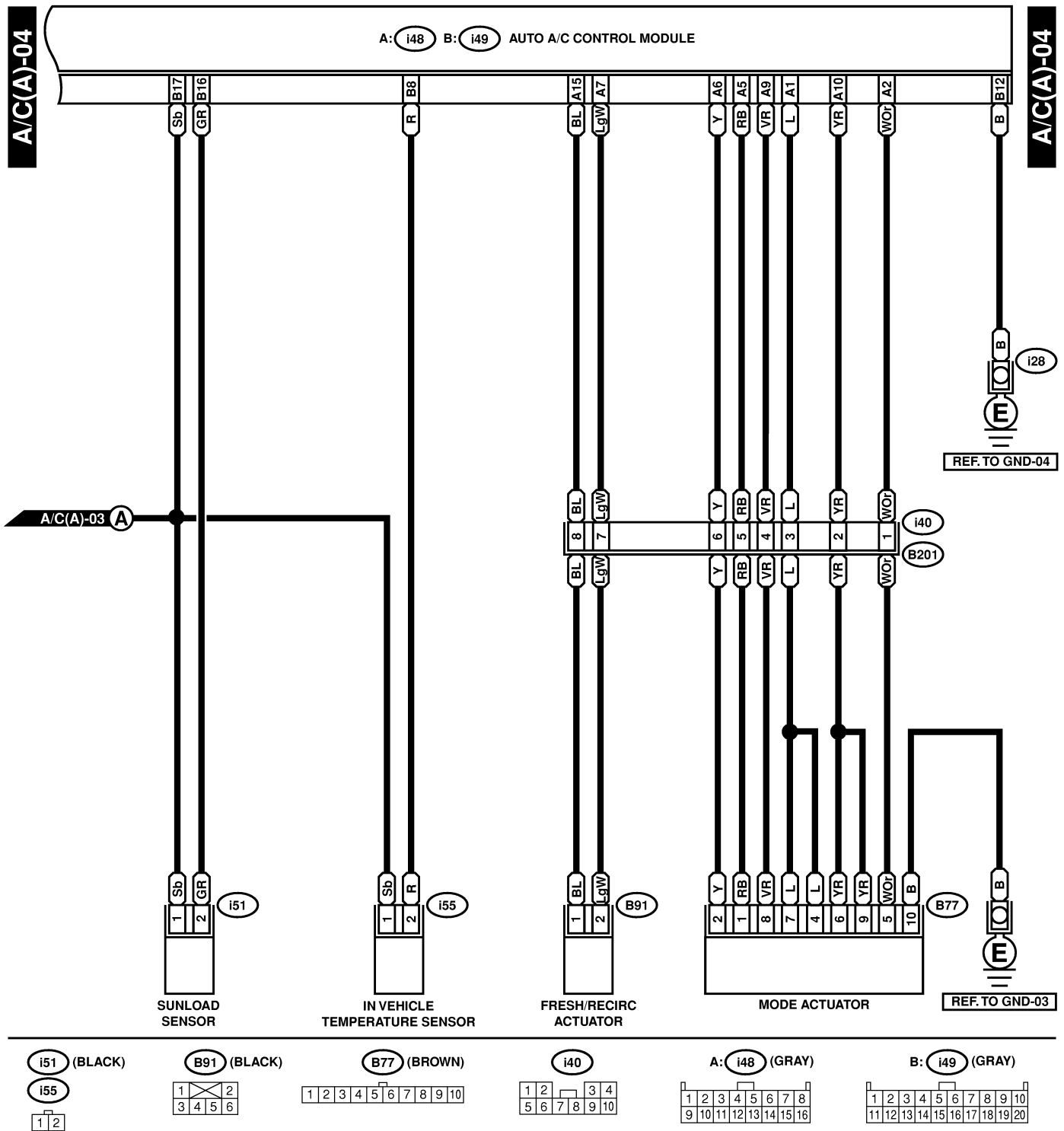

A/C CONTROL MODULE I/O SIGNAL

HVAC System (Auto A/C) (DIAGNOSTICS)

4. A/C Control Module I/O Signal S001518

A: ELECTRICAL SPECIFICATION S001518A08

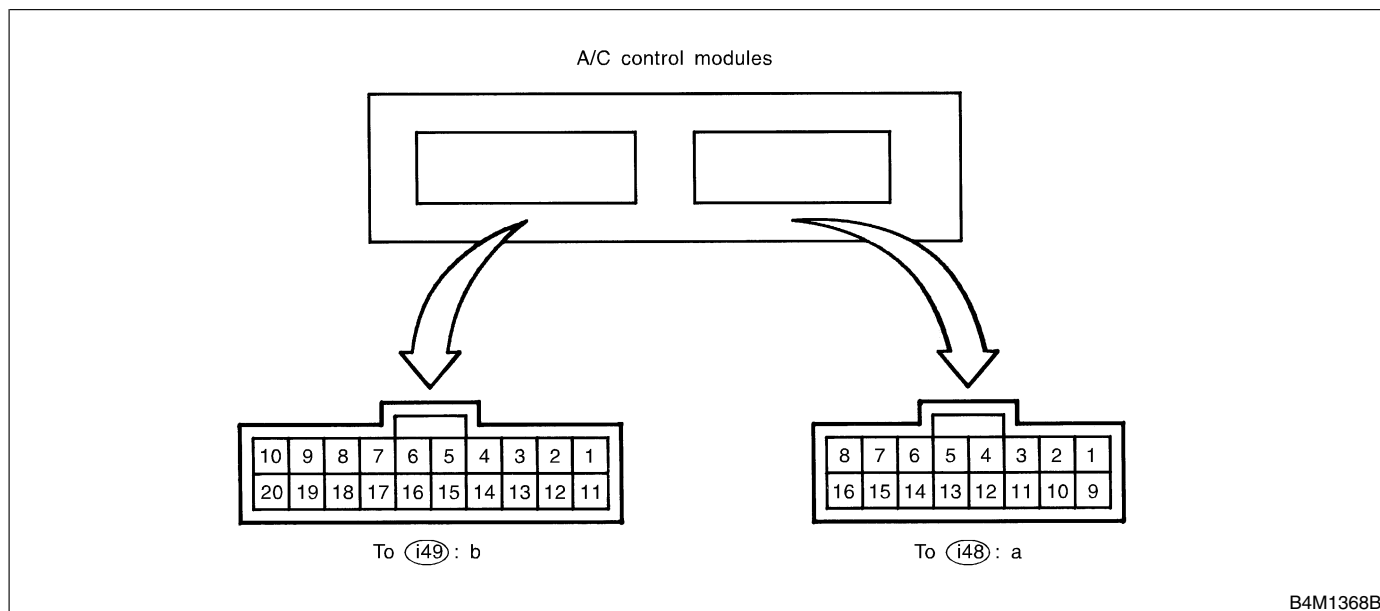

Content	Connector & Terminal No.	Signal (V)
BATT voltage (Memory back-up)	b1—b12	BATT voltage, 13 — 14 (engine running)
IGN power supply	a8—b12	Battery voltage (ignition switch ON), 13 — 14 (engine running)
ACC power supply (OFF: ignition in START or diagnosis system reset)	b2—b12	BATT voltage, 0 (engine cranking), BATT voltage (during engine starts)
A/C control module ground circuit	b12—body	0 (ignition switch ON) — circuit constantly grounded
Sensor ground circuit	b17—body	0 (ignition switch ON) — continuity exists
Ambient sensor	b6—b17	Approx. 3.3 (disconnect connector, and ignition switch ON)
Evaporator sensor	b7—b17	
Thermometer	b15—b12	
Sunload sensor	b16—b17	Approx. 4.2 (disconnect connector, and ignition switch ON)
Air mix door motor	a4—a3	BATT voltage (AUTO mode) positive “+” at terminal “a4” and negative “-” at “a3” [temperature set at 18°C (65°F)]; negative “-” at terminal “a4” and positive “+” at “a13” [temperature set at 32°C (85°F)]
Air mix door motor P.B.R.	a12—b17	Approx. 0.5 [temperature set at 18°C (65°F) in AUTO mode] Approx. 4.5 [temperature set at 32°C (85°F) in AUTO mode]
Mode actuator VENT	a5—b17	BATT voltage (ignition switch ON in MANUAL mode); positive “+” at terminal “a5” and negative “-” at “b17” (VENT); negative “-” at “a5” and positive “+” at “b17” (DEF)
Mode actuator DEF	a6—b17	BATT voltage (ignition switch ON in MANUAL mode) Approx. 4.5 (VENT); approx. 0.5 (DEF)
Intake door FRS voltage	a7—a15	BATT voltage (CIRC switch OFF)
Intake door CIRC voltage	a15—a7	BATT voltage (CIRC switch ON)
Blower fan relay	b14—body	BATT voltage (ignition switch ON)
A/C relay	b3—b12	0 (ignition and A/C switches ON) BATT voltage (A/C switch OFF)
Illumination control signal	b10—b20	BATT voltage (ignition and lighting switches ON)
Rear defogger	a13—b12	0 (IGN ON, R Def SW ON)

A/C CONTROL MODULE I/O SIGNAL

HVAC System (Auto A/C) (DIAGNOSTICS)

B: SCHEMATIC

S001518A21

1. AIR CONDITIONER AUTO A/C

S001518A2103

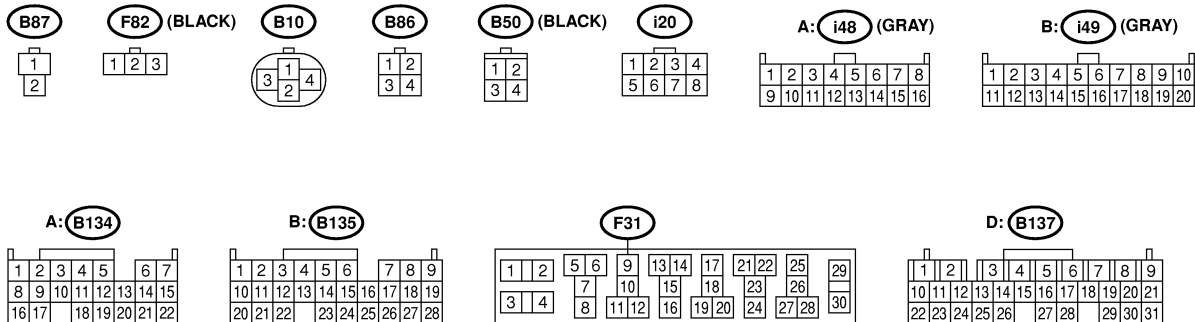
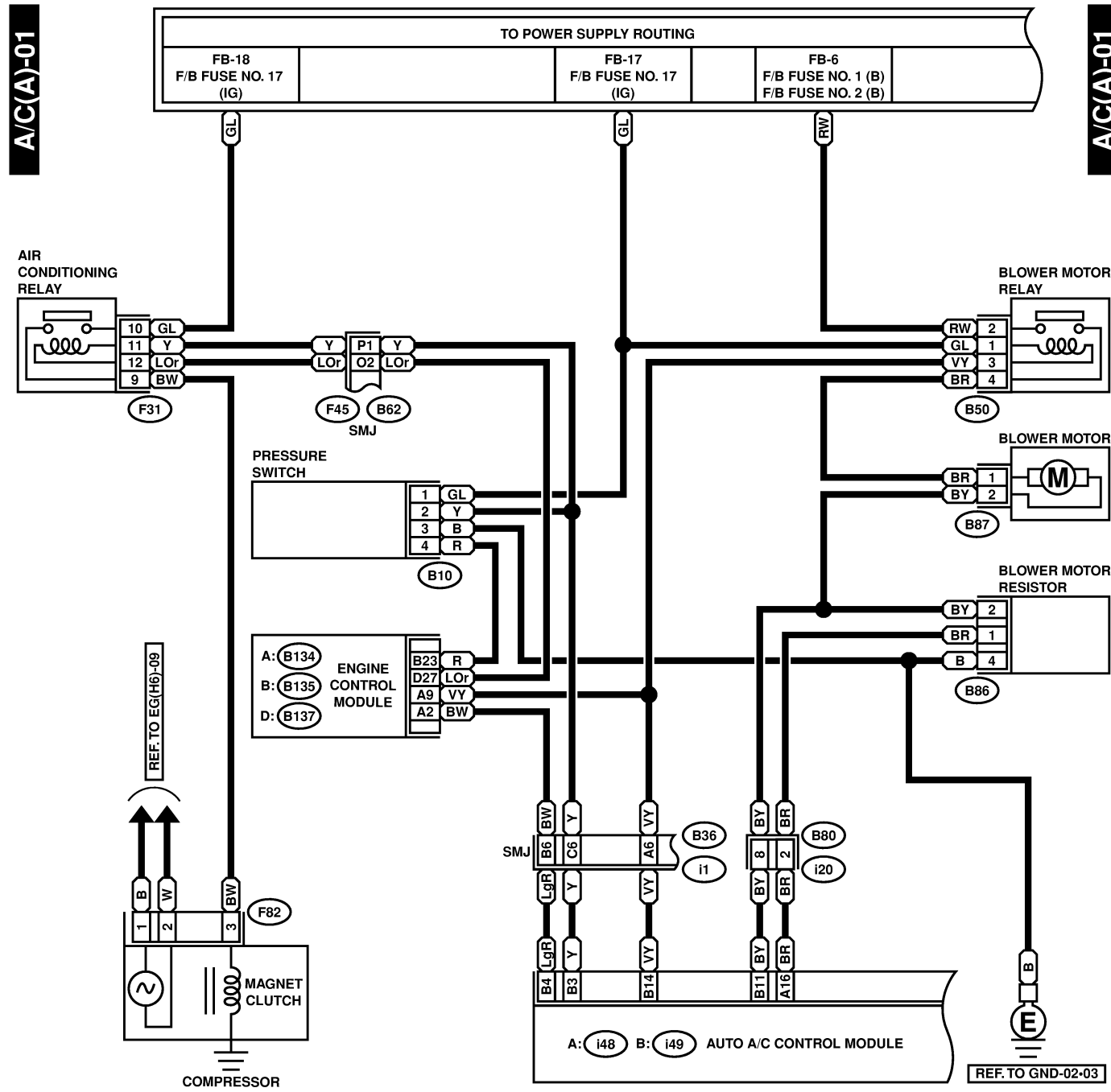

RELAY HOLDER (BLACK)

BU46-20A

A/C CONTROL MODULE I/O SIGNAL

HVAC System (Auto A/C) (DIAGNOSTICS)

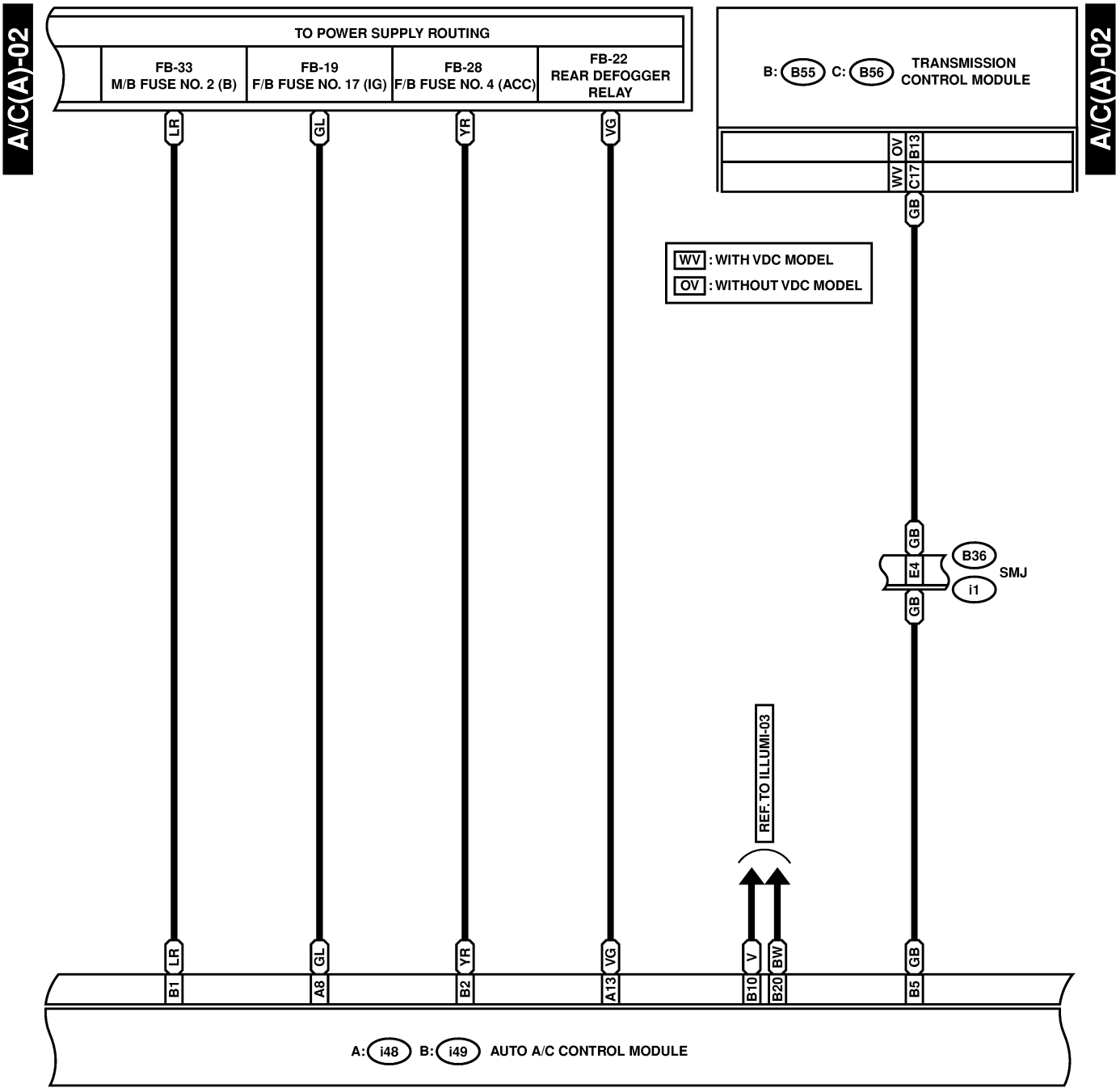

A: i48 (GRAY)

1	2	3	4	5	6	7	8
9	10	11	12	13	14	15	16

B: i49 (GRAY)

1	2	3	4	5	6	7	8	9	10
11	12	13	14	15	16	17	18	19	20

C: B56 (GREEN)

1	2	3	4	5	6	7	8	9
10	11	12	13	14	15	16	17	18
19	20	21				22	23	24

B: B55 (GRAY)

1	2	3	4	5	6	7	8	9
10	11	12	13	14	15	16	17	18
19	20	21				22	23	24

A/C CONTROL MODULE I/O SIGNAL

HVAC System (Auto A/C) (DIAGNOSTICS)

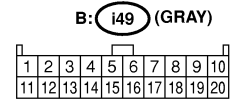
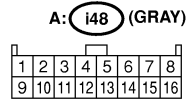
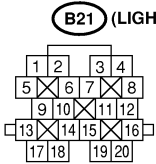
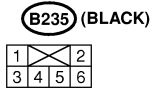
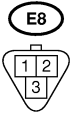
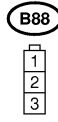
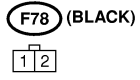
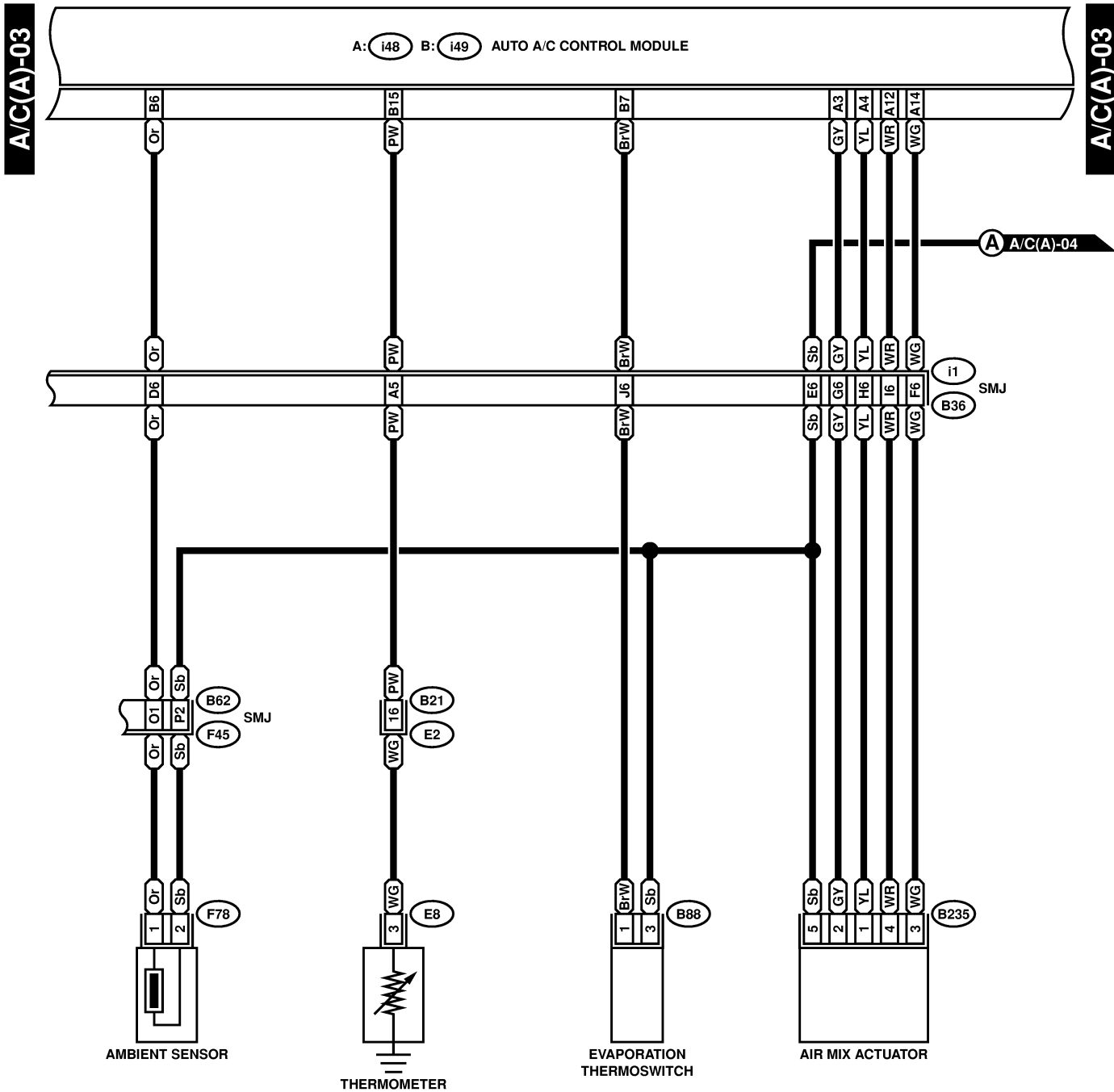

A/C CONTROL MODULE I/O SIGNAL

HVAC System (Auto A/C) (DIAGNOSTICS)

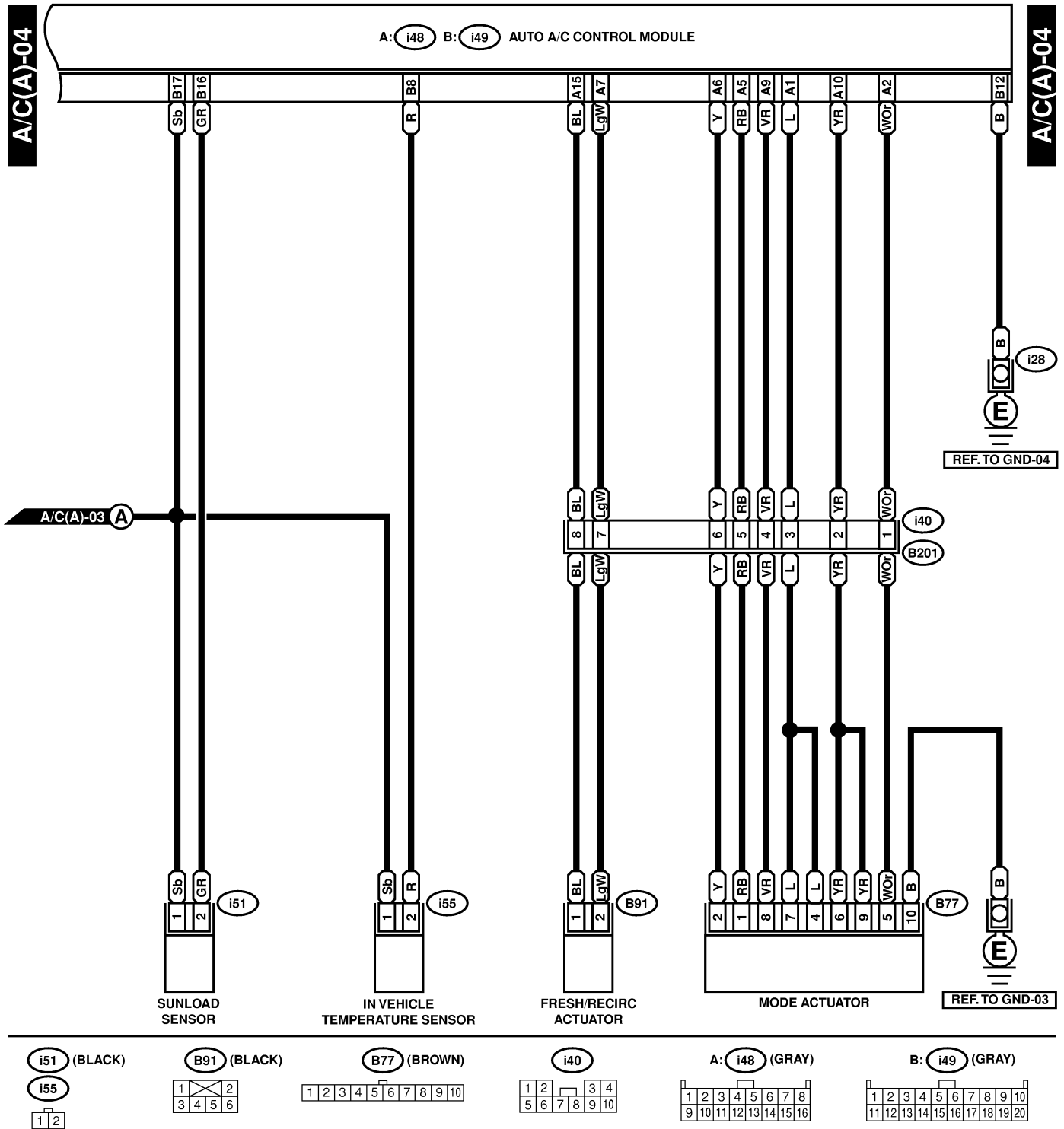

DIAGNOSTICS CHART FOR DIAGNOSIS SYSTEM

HVAC System (Auto A/C) (DIAGNOSTICS)

5. Diagnostics Chart for Diagnosis System S001624

A: SELF-DIAGNOSIS MODE S001624F36

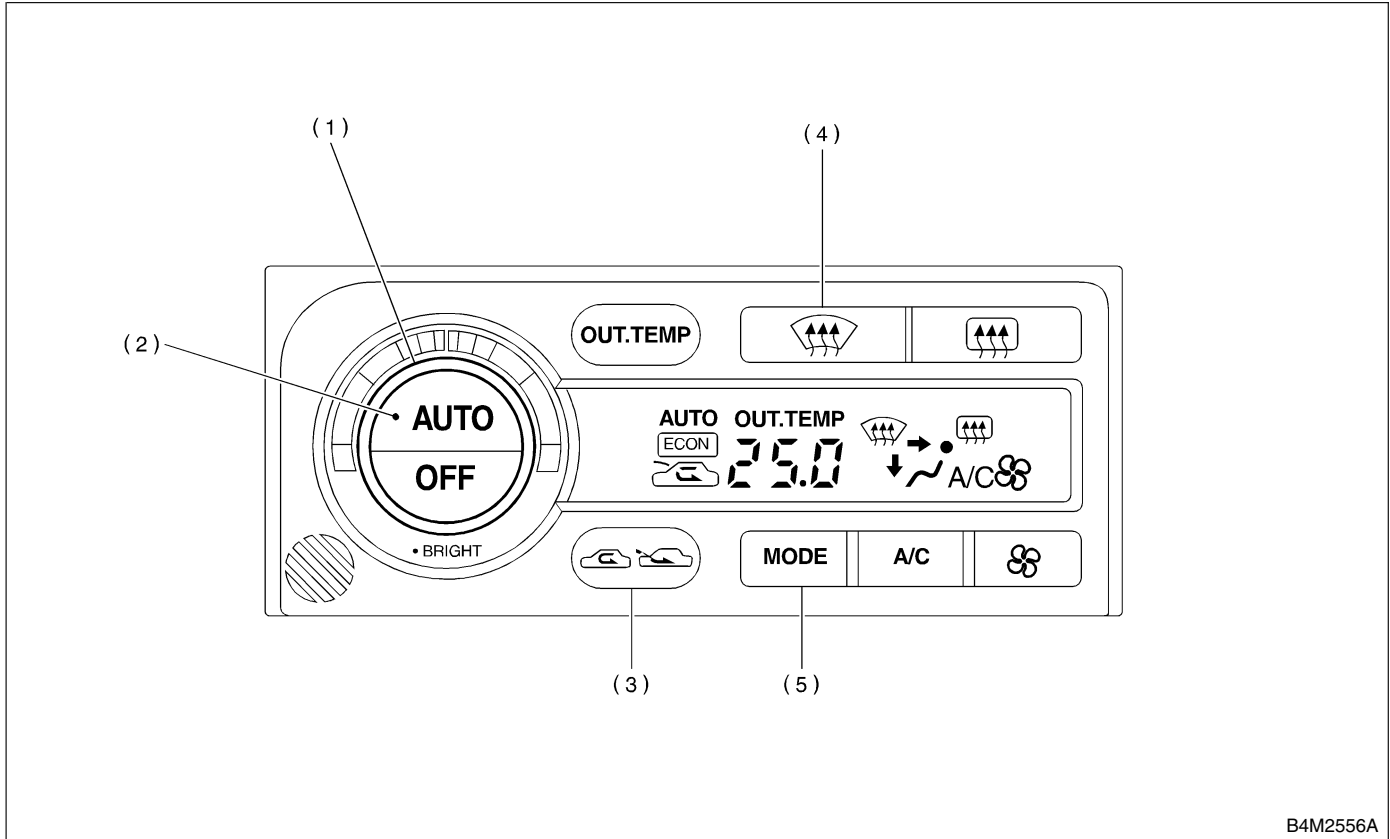

B4M2556A

(1) Temperature select dial
(2) AUTO switch

(3) REC switch
(4) DEF switch

(5) MODE switch

DIAGNOSTICS CHART FOR DIAGNOSIS SYSTEM

HVAC System (Auto A/C) (DIAGNOSTICS)

No.	Step	Check	Yes	No
1	SELECT CONTROL PANEL TO SELF-DIAGNOSIS MODE. 1) Turn ignition switch to OFF. 2) While pushing "AUTO" and "REC" switches, start the engine.	Can it be moved to the self-diagnosis mode?	Go to step 2.	<Ref. to AC-16, A/C AND/OR SELF-DIAGNOSIS SYSTEMS DO NOT OPERATE, Diagnostics for A/C System Failure.>
2	CHECK INDICATOR. 1) Turn temperature select dial clockwise by one click. 2) Make sure that all characters illuminate on the display.	Does each character illuminate?	Go to step 3.	Go to step 7.
3	CHECK EACH SENSOR AND EACH POTENTIOMETER. 1) Turn temperature select dial clockwise by one click. 2) If system has the trouble for each sensor and/or each potentiometer, trouble code is indicated on indicator. 3) If system has no trouble, code "20" is indicated on indicator. NOTE: When the sunload sensor is checked inside the passenger compartment or in the shade, code "25" may appear on the indicator. Always check the sunload sensor in a place where it senses direct sunlight.	Is the code "20" indicated on indicator?	Go to step 4.	Repair each trouble code.
4	CHECK DOOR MOTOR POSITION SWITCH. 1) Turn temperature select dial clockwise by one click. 2) If system has the trouble for each door position switch, trouble code is indicated on indicator. 3) If system has no trouble, code "30" is indicated on indicator.	Is the code "30" indicated on indicator?	Go to step 5.	Repair each trouble code.
5	CHECK OPERATION OF EACH ACTUATOR, BLOWER FAN AND COMPRESSOR CLUTCH. 1) Turn temperature select dial clockwise by one click. 2) Select operating mode by pushing every "DEF" switch. 3) Check the operation for each mode. <ul style="list-style-type: none"> ● Air inlet: ● Air outlet: ● Air mix door: ● Blower fan: ● A/C compressor: 	Does each mode displayed match the operating mode table? <Ref. to AC-14, OPERATING MODE TABLE, SELF-DIAGNOSIS MODE, Diagnostics Chart for Diagnosis System.>	Go to step 6.	Go to step 7.

DIAGNOSTICS CHART FOR DIAGNOSIS SYSTEM

HVAC System (Auto A/C) (DIAGNOSTICS)

No.	Step	Check	Yes	No
6	CHECK INDICATED VALUE OF EACH SENSOR. 1) Turn temperature select dial clockwise by one click. 2) Each time the "DEF" switch is pressed, the value indicated on the display changes to correspond with the ambient sensor, in-vehicle sensor and intake sensor, in that order. 3) Make sure there is no big difference between the temperature indicated on the display and the measured temperature. NOTE: If a large temperature difference is noted, check for ECM standard voltage and sensor function using the performance characteristic diagram.	Is a proper input signal value displayed in each sensor?	End	Go to step 7.
7	CHECK POOR CONTACT. Check poor contact in A/C control module.	Is there poor contact in A/C control module?	Repair poor contact in A/C control module.	Contact with SOA (distributor) service.

1. OPERATING MODE TABLE S001624F3601

Mode display	41	42	43	44	45	46	47	48
Air inlet	REC	REC	REC	FRE	FRE	FRE	FRE	FRE
Air outlet	VENT	VENT	B/L	B/L	B/L	HEAT	D/H	DEF
Air mix door	FULL COOL	FULL COOL	FULL COOL	FULL HOT	FULL HOT	FULL HOT	FULL HOT	FULL HOT
Blower fan	5 V	5 V	Power supply voltage	8.5 V	8.5 V	8.5 V	8.5 V	Power supply voltage
A/C compressor	ON	ON	ON	OFF	OFF	OFF	ON	ON

DIAGNOSTICS CHART FOR DIAGNOSIS SYSTEM

HVAC System (Auto A/C) (DIAGNOSTICS)

MEMO:

DIAGNOSTICS CHART FOR DIAGNOSIS SYSTEM

HVAC System (Auto A/C) (DIAGNOSTICS)

5. Diagnostics Chart for Diagnosis System S001624

A: SELF-DIAGNOSIS MODE S001624F36

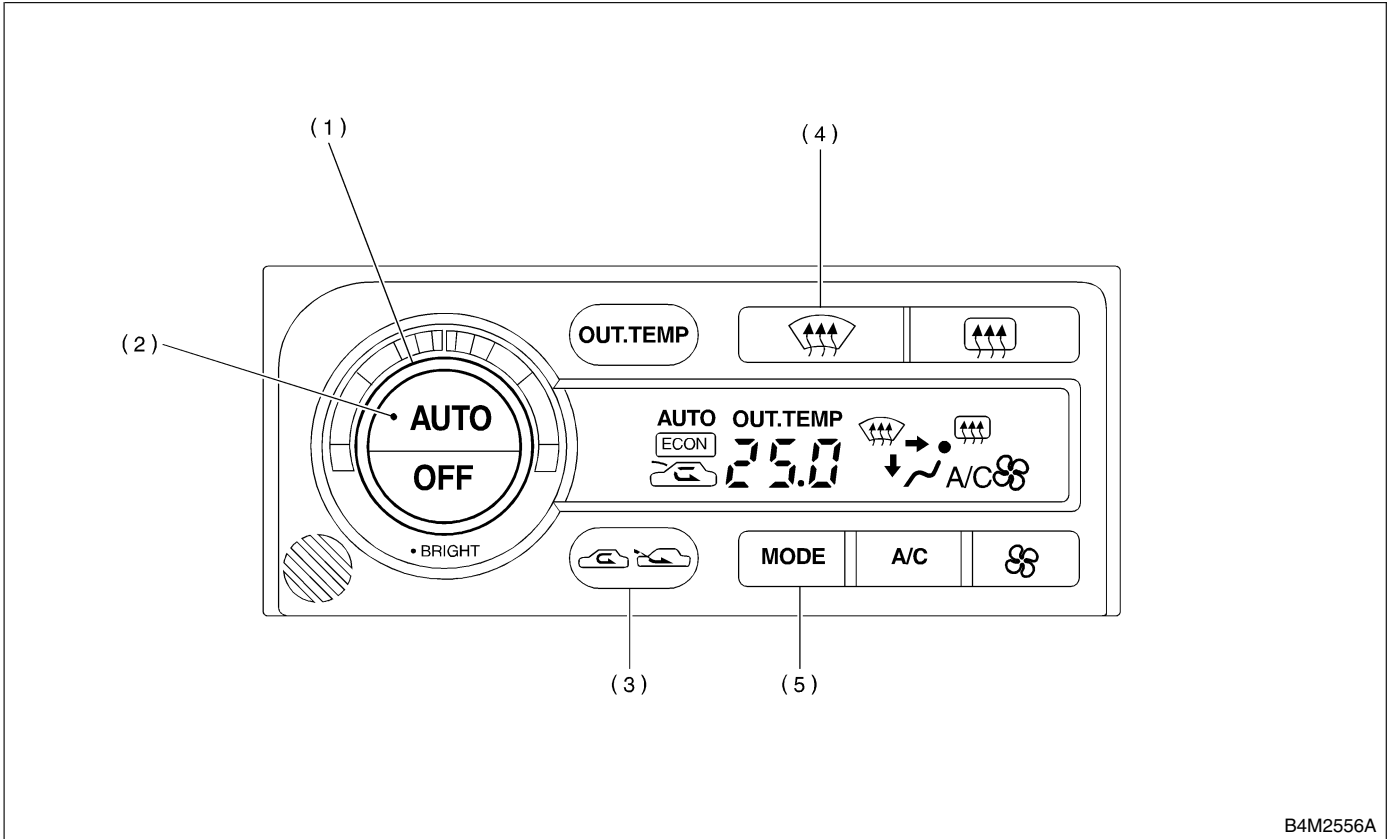

B4M2556A

(1) Temperature select dial
(2) AUTO switch

(3) REC switch
(4) DEF switch

(5) MODE switch

DIAGNOSTICS CHART FOR DIAGNOSIS SYSTEM

HVAC System (Auto A/C) (DIAGNOSTICS)

No.	Step	Check	Yes	No
1	SELECT CONTROL PANEL TO SELF-DIAGNOSIS MODE. 1) Turn ignition switch to OFF. 2) While pushing "AUTO" and "REC" switches, start the engine.	Can it be moved to the self-diagnosis mode?	Go to step 2.	<Ref. to AC-16, A/C AND/OR SELF-DIAGNOSIS SYSTEMS DO NOT OPERATE, Diagnostics for A/C System Failure.>
2	CHECK INDICATOR. 1) Turn temperature select dial clockwise by one click. 2) Make sure that all characters illuminate on the display.	Does each character illuminate?	Go to step 3.	Go to step 7.
3	CHECK EACH SENSOR AND EACH POTENTIOMETER. 1) Turn temperature select dial clockwise by one click. 2) If system has the trouble for each sensor and/or each potentiometer, trouble code is indicated on indicator. 3) If system has no trouble, code "20" is indicated on indicator. NOTE: When the sunload sensor is checked inside the passenger compartment or in the shade, code "25" may appear on the indicator. Always check the sunload sensor in a place where it senses direct sunlight.	Is the code "20" indicated on indicator?	Go to step 4.	Repair each trouble code.
4	CHECK DOOR MOTOR POSITION SWITCH. 1) Turn temperature select dial clockwise by one click. 2) If system has the trouble for each door position switch, trouble code is indicated on indicator. 3) If system has no trouble, code "30" is indicated on indicator.	Is the code "30" indicated on indicator?	Go to step 5.	Repair each trouble code.
5	CHECK OPERATION OF EACH ACTUATOR, BLOWER FAN AND COMPRESSOR CLUTCH. 1) Turn temperature select dial clockwise by one click. 2) Select operating mode by pushing every "DEF" switch. 3) Check the operation for each mode. <ul style="list-style-type: none"> ● Air inlet: ● Air outlet: ● Air mix door: ● Blower fan: ● A/C compressor: 	Does each mode displayed match the operating mode table? <Ref. to AC-14, OPERATING MODE TABLE, SELF-DIAGNOSIS MODE, Diagnostics Chart for Diagnosis System.>	Go to step 6.	Go to step 7.

DIAGNOSTICS CHART FOR DIAGNOSIS SYSTEM

HVAC System (Auto A/C) (DIAGNOSTICS)

No.	Step	Check	Yes	No
6	CHECK INDICATED VALUE OF EACH SENSOR. 1) Turn temperature select dial clockwise by one click. 2) Each time the "DEF" switch is pressed, the value indicated on the display changes to correspond with the ambient sensor, in-vehicle sensor and intake sensor, in that order. 3) Make sure there is no big difference between the temperature indicated on the display and the measured temperature. NOTE: If a large temperature difference is noted, check for ECM standard voltage and sensor function using the performance characteristic diagram.	Is a proper input signal value displayed in each sensor?	End	Go to step 7.
7	CHECK POOR CONTACT. Check poor contact in A/C control module.	Is there poor contact in A/C control module?	Repair poor contact in A/C control module.	Contact with SOA (distributor) service.

1. OPERATING MODE TABLE S001624F3601

Mode display	41	42	43	44	45	46	47	48
Air inlet	REC	REC	REC	FRE	FRE	FRE	FRE	FRE
Air outlet	VENT	VENT	B/L	B/L	B/L	HEAT	D/H	DEF
Air mix door	FULL COOL	FULL COOL	FULL COOL	FULL HOT	FULL HOT	FULL HOT	FULL HOT	FULL HOT
Blower fan	5 V	5 V	Power supply voltage	8.5 V	8.5 V	8.5 V	8.5 V	Power supply voltage
A/C compressor	ON	ON	ON	OFF	OFF	OFF	ON	ON

DIAGNOSTICS CHART FOR DIAGNOSIS SYSTEM

HVAC System (Auto A/C) (DIAGNOSTICS)

MEMO:

DIAGNOSTICS FOR A/C SYSTEM FAILURE

HVAC System (Auto A/C) (DIAGNOSTICS)

6. Diagnostics for A/C System Failure S001625

A: A/C AND/OR SELF-DIAGNOSIS SYSTEMS DO NOT OPERATE S001625F37

TROUBLE SYMPTOM:

- "Set" temperature is not indicated on display, switch LEDs are faulty and switches do not operate.
- Self-diagnosis system does not operate.

WIRING DIAGRAM:

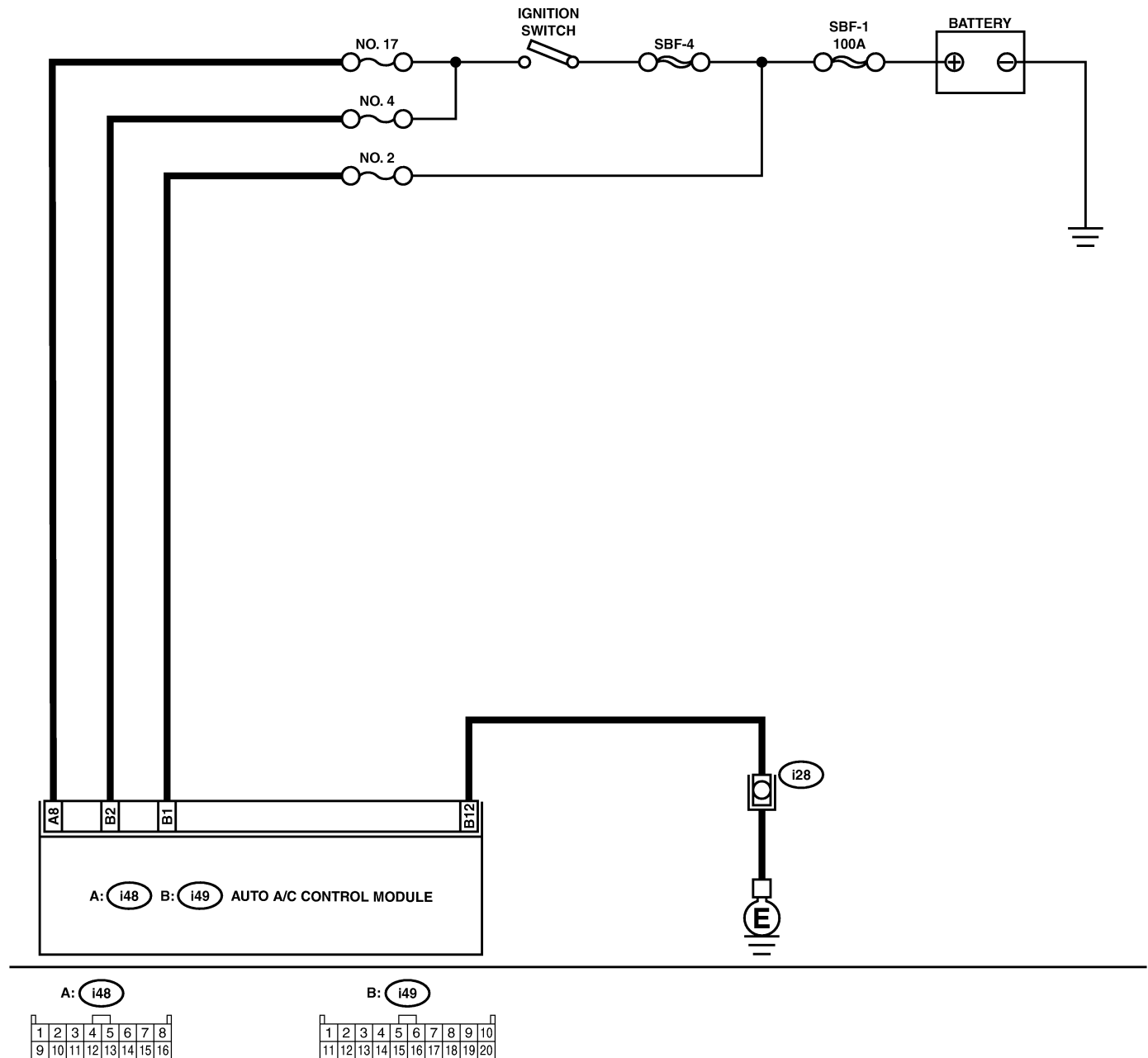

DIAGNOSTICS FOR A/C SYSTEM FAILURE

HVAC System (Auto A/C) (DIAGNOSTICS)

No.	Step	Check	Yes	No
1	CHECK FUSE. 1) Turn ignition switch to OFF. 2) Remove fuse No. 2 from main fuse box. 3) Check condition of fuse.	Is the fuse blown-out?	Replace fuse.	Go to step 2.
2	CHECK FUSE. 1) Turn ignition switch to OFF. 2) Remove fuses No. 4 and No. 17 from joint box. 3) Check condition of fuse.	Is the fuse blown-out?	Replace fuse.	Go to step 3.
3	CHECK A/C CONTROL MODULE POWER CIRCUIT. 1) Pull out A/C control module connector. 2) Measure voltage between A/C control module connector terminal and chassis ground when turning ignition switch to OFF. <i>Connector & terminal</i> <i>(i49) No. 1 (+) — Chassis ground (-):</i>	Is the voltage more than 10 V?	Go to step 4.	Repair short circuit in harness for power supply line.
4	CHECK A/C CONTROL MODULE POWER CIRCUIT. Measure voltage between A/C control module connector terminal and chassis ground when turning ignition switch to ACC. <i>Connector & terminal</i> <i>(i49) No. 2 (+) — Chassis ground (-):</i>	Is the voltage more than 10 V?	Go to step 5.	Repair short circuit in harness for power supply line.
5	CHECK A/C CONTROL MODULE POWER CIRCUIT. Measure voltage between A/C control module connector terminal and chassis ground when turning ignition switch to ON. <i>Connector & terminal</i> <i>(i48) No. 8 (+) — Chassis ground (-):</i>	Is the voltage more than 10 V?	Go to step 6.	Repair short circuit in harness for power supply line.
6	CHECK A/C CONTROL MODULE GROUND CIRCUIT. Measure resistance of harness between A/C control module and chassis ground. <i>Connector & terminal</i> <i>(i49) No. 12 — Chassis ground:</i>	Is the resistance less than 5 Ω ?	Go to step 7.	Repair short circuit in harness for ground line.
7	CHECK POOR CONTACT. Check poor contact in A/C control module.	Is there poor contact in A/C control module?	Repair poor contact in A/C control module.	Contact with SOA (distributor) service.

DIAGNOSTICS FOR A/C SYSTEM FAILURE

HVAC System (Auto A/C) (DIAGNOSTICS)

B: BLOWER MOTOR IS NOT ROTATED S001625F38

TROUBLE SYMPTOM:

- Blower motor is not rotated.
- Blower motor is not rotated in "HI".

WIRING DIAGRAM:

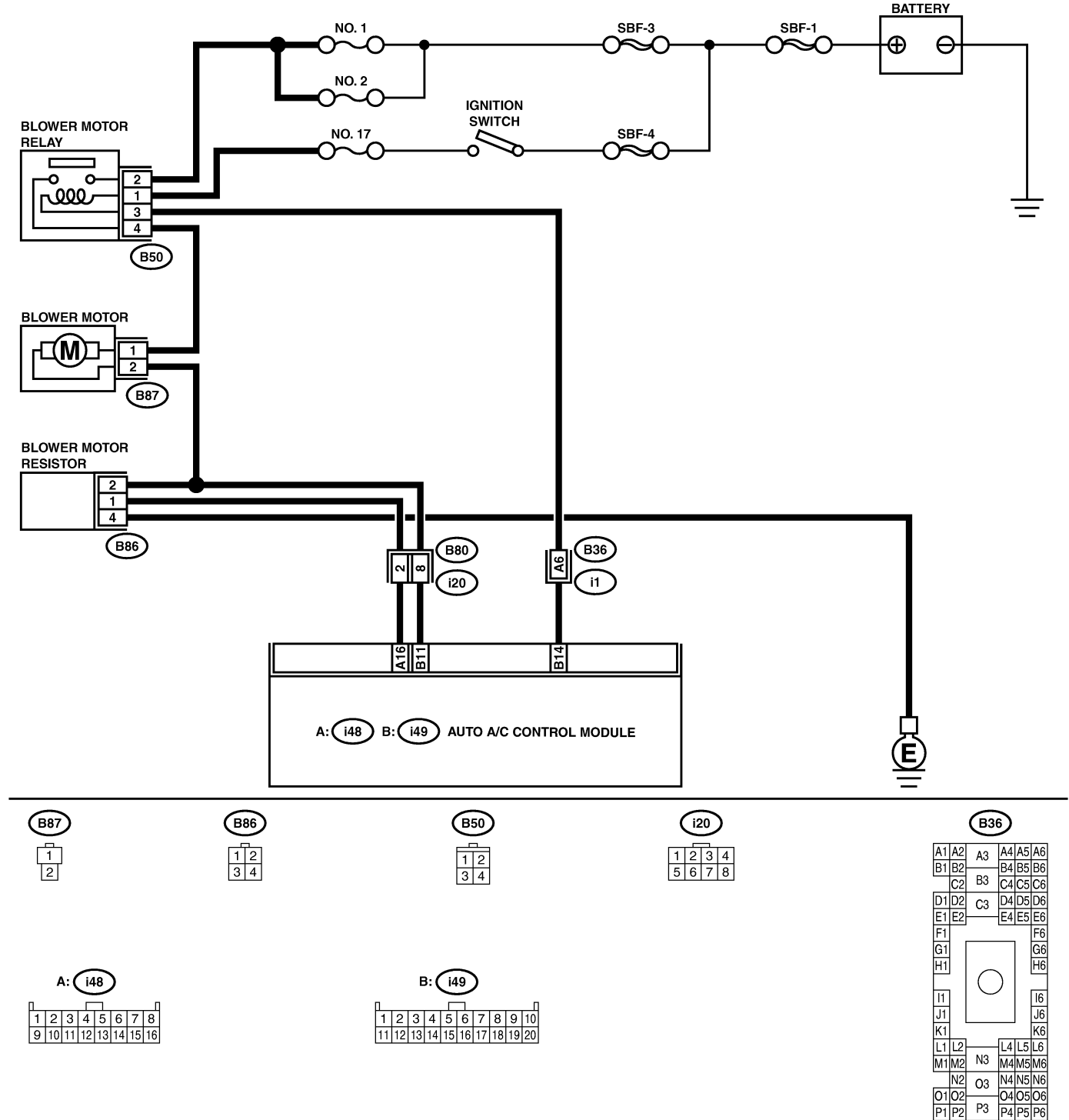

B4M2372

DIAGNOSTICS FOR A/C SYSTEM FAILURE

HVAC System (Auto A/C) (DIAGNOSTICS)

No.	Step	Check	Yes	No
1	CHECK FUSE. 1) Remove No. 2 and No. 17 fuses in joint box. 2) Check condition of fuses.	Are any of the fuses blown-out?	Replace fuse.	Go to step 2.
2	CHECK POWER SUPPLY TO BLOWER FAN MOTOR. 1) Turn ignition switch to ON. 2) Turn blower switch to ON. 3) Measure voltage between blower fan motor and chassis ground. Connector & terminal (B87) No. 1 (+) — Chassis ground (-):	Is the voltage more than 10 V?	Go to step 3.	Repair open circuit in harness for blower fan motor power supply line.
3	CHECK BLOWER FAN MOTOR RELAY. 1) Turn ignition switch to OFF. 2) Remove blower fan motor relay. 3) Connect battery to No. 1 and No. 3 terminals of blower fan motor connector. 4) Measure resistance between No. 2 and No. 4 terminals. Terminals: No. 2 — No. 4	Is the resistance less than 1 Ω ?	Go to step 4.	Replace blower fan motor relay.
4	CHECK BLOWER FAN MOTOR. 1) Disconnect connector from blower fan motor. 2) Connect battery to connector terminals of blower fan motor. 3) Make sure that blower fan motor is operated.	Does the blower fan motor operate?	Go to step 5.	Replace blower fan motor.
5	CHECK POOR CONTACT. Check poor contact in A/C control module.	Is there poor contact in A/C control module?	Repair poor contact in A/C control module.	Contact with SOA (distributor) service.

DIAGNOSTICS FOR A/C SYSTEM FAILURE

HVAC System (Auto A/C) (DIAGNOSTICS)

C: FRESH/RECIRC IS NOT CHANGED S001625F39

TROUBLE SYMPTOM:

FRESH/RECIRC mode door is not changed.

WIRING DIAGRAM:

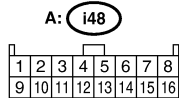
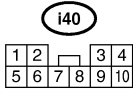
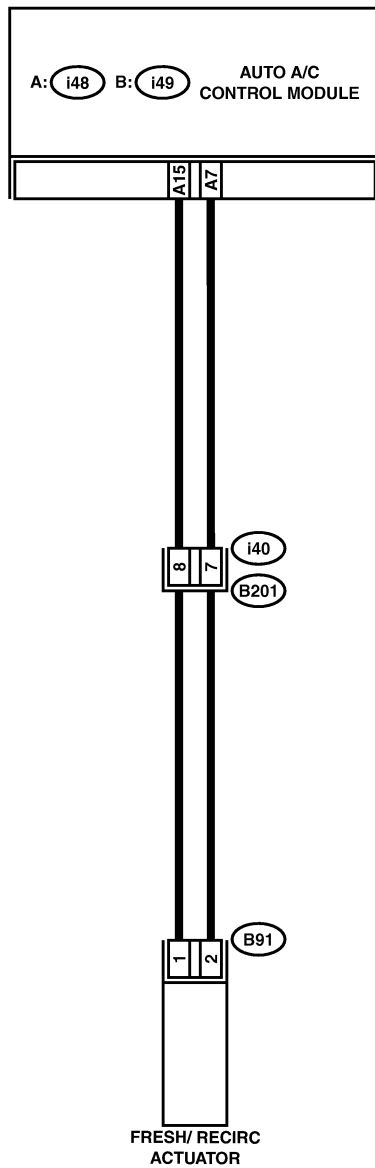

B4M2373

DIAGNOSTICS FOR A/C SYSTEM FAILURE

HVAC System (Auto A/C) (DIAGNOSTICS)

No.	Step	Check	Yes	No
1	CHECK SWITCH OPERATION. Make sure that the mode selection on display is changed when pushing the "MODE" switch.	Does the mode selection change?	Go to step 7.	Go to step 2.
2	CHECK FUSE. 1) Remove No. 17 fuse in joint box. 2) Check condition of fuse.	Is the fuse blown-out?	Replace fuse.	Go to step 3.
3	CHECK SIGNAL VOLTAGE. 1) Change display to RECIRC by pushing MODE switch. 2) Measure voltage between A/C control module and chassis ground. Connector & terminal <i>(i48) No. 15 (+) — Chassis ground (-):</i>	Is the voltage less than 1 V?	Go to step 4.	Repair short circuit in harness for power supply line.
4	CHECK SIGNAL VOLTAGE. 1) Change display to FRESH with pushing MODE switch. 2) Measure voltage between A/C control module and chassis ground. Connector & terminal <i>(i48) No. 7 (+) — Chassis ground (-):</i>	Is the voltage less than 1 V?	Go to step 5.	Repair short circuit in harness for power supply line.
5	CHECK HARNESS CONNECTOR BETWEEN A/C CONTROL MODULE AND FRESH/RECIRC ACTUATOR. 1) Turn ignition switch to OFF. 2) Disconnect connector from A/C control module and mode door motor. 3) Measure resistance of harness between A/C control module and FRESH/RECIRC actuator. Connector & terminal: <i>(i48) No. 15 — (B91) No. 1</i>	Is the resistance less than 1 Ω ?	Go to step 6.	Repair open circuit in harness between A/C control module and FRESH/RECIRC actuator.
6	CHECK HARNESS CONNECTOR BETWEEN A/C CONTROL MODULE AND FRESH/RECIRC ACTUATOR. Measure resistance of harness between A/C control module and FRESH/RECIRC actuator. Connector & terminal: <i>(i48) No. 7 — (B91) No. 2</i>	Is the resistance less than 1 Ω ?	Go to step 7.	Repair open circuit in harness between A/C control module and FRESH/RECIRC actuator.
7	CHECK POOR CONTACT. Check poor contact in A/C control module.	Is there poor contact in A/C control module?	Repair poor contact in A/C control module.	Contact with SOA (distributor) service.

DIAGNOSTICS FOR A/C SYSTEM FAILURE

HVAC System (Auto A/C) (DIAGNOSTICS)

D: COMPARTMENT TEMPERATURE IS NOT CHANGED OR A/C SYSTEM DOES NOT RESPOND QUICKLY

S001625F40

WIRING DIAGRAM:

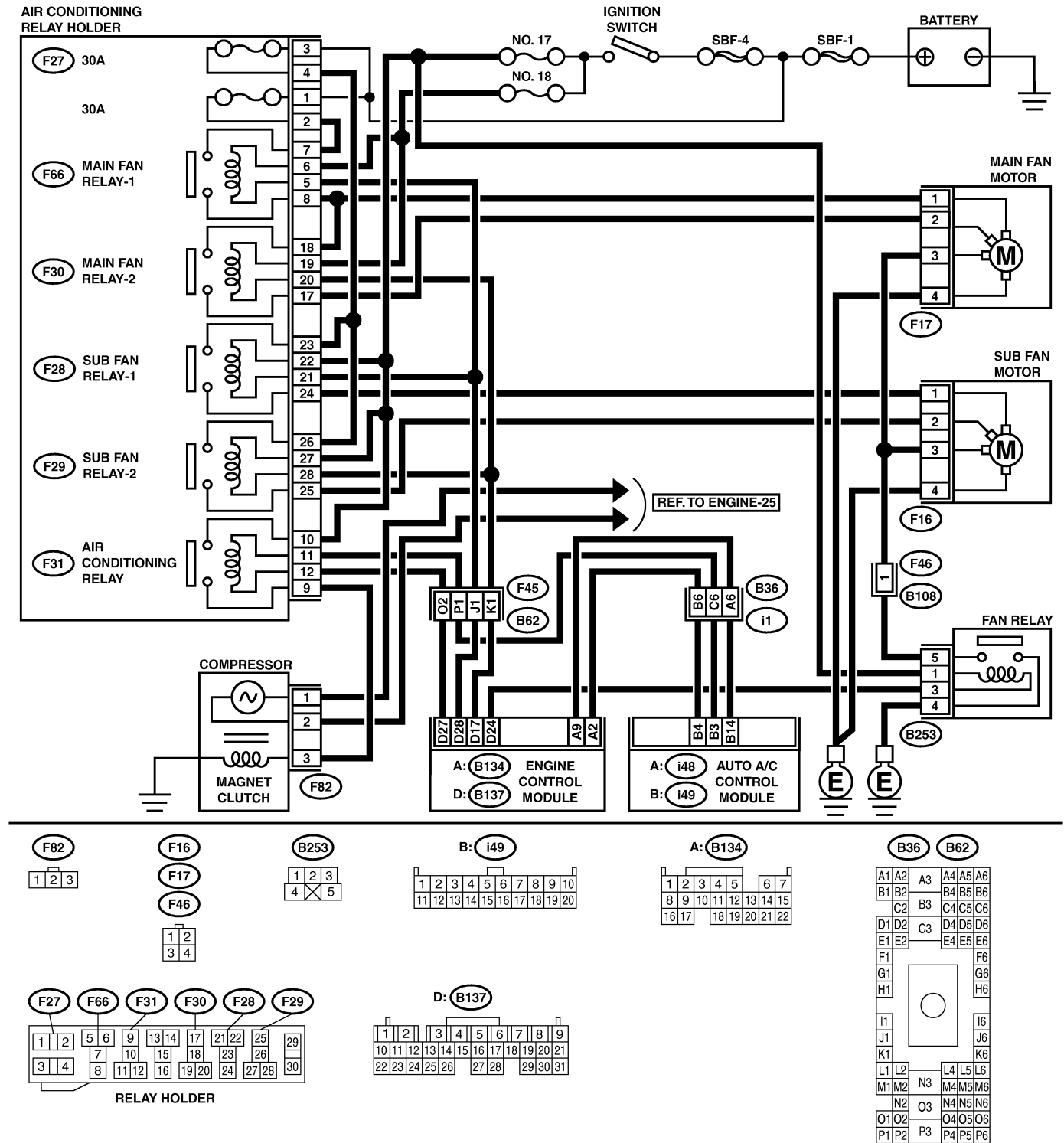

B4M2374

DIAGNOSTICS FOR A/C SYSTEM FAILURE

HVAC System (Auto A/C) (DIAGNOSTICS)

No.	Step	Check	Yes	No
1	CHECK FUSE. 1) Turn ignition switch to OFF. 2) Remove No. 2 fuse in main fuse box. 3) Check condition of fuse.	Is the fuse blown-out?	Replace fuse.	Go to step 2.
2	CHECK POWER SUPPLY TO MAGNET CLUTCH OF A/C COMPRESSOR. 1) Start the engine, and turn A/C switch to ON. 2) Set the compartment temperature at 18°C (65°F) (MAX COOL). 3) Measure voltage between magnet clutch connector and chassis ground. Connector & terminal (F82) No. 3 (+) — Chassis ground (-):	Is the voltage more than 10 V?	Go to step 3.	Repair open circuit in harness for power supply line of the A/C compressor.
3	CHECK SIGNAL VOLTAGE TO A/C RELAY. 1) Turn ignition switch to ON. 2) Turn A/C switch to ON. 3) Measure signal voltage to A/C relay and chassis ground. Connector & terminal (F31) No. 9 (+) — Chassis ground (-):	Is the voltage more than 10 V?	Go to step 4.	Repair open circuit in harness for power supply line.
4	CHECK A/C RELAY. 1) Remove A/C relay in main fuse box. 2) Check A/C relay. <Ref. to AC-40, INSPECTION, Relay and Fuse.>	Is the operation of each relay OK?	Go to step 5.	Replace A/C relay.
5	CHECK OPERATION OF MAIN FAN MOTOR. 1) Start the engine. 2) Turn A/C switch to ON. 3) Check operation of main fan motor.	Does the radiator main fan operate?	Go to step 10.	Go to step 6.
6	CHECK POWER SUPPLY TO MAIN FAN MOTOR. CAUTION: Be careful not to overheat engine during repair. 1) Turn ignition switch to OFF. 2) Disconnect connector from main fan motor. 3) Start the engine, and warm it up until engine coolant temperature increases over 95°C (203°F). 4) Stop the engine and turn ignition switch to ON. 5) Measure voltage between main fan motor connector and chassis ground. Connector & terminal (F17) No. 1, 2 (+) — Chassis ground (-):	Is the voltage more than 10 V?	Go to step 7.	Repair open circuit in harness for power supply circuit.
7	CHECK GROUND CIRCUIT OF MAIN FAN MOTOR. 1) Turn ignition switch to OFF. 2) Measure resistance between main fan motor connector and chassis ground. Connector & terminal (F17) No. 4 — Chassis ground:	Is the resistance less than 1 Ω?	Go to step 8.	Repair open circuit in harness between main fan motor connector and chassis ground.
8	CHECK POOR CONTACT. Check poor contact in main fan motor connector.	Is there poor contact in main fan motor connector?	Repair poor contact in main fan motor connector.	Go to step 9.

DIAGNOSTICS FOR A/C SYSTEM FAILURE

HVAC System (Auto A/C) (DIAGNOSTICS)

No.	Step	Check	Yes	No
9	CHECK MAIN FAN MOTOR. Connect battery positive (+) terminal to terminal No. 1, 2, and negative (-) terminal to terminal No. 4 of main fan motor connector.	Does the main fan rotate?	Repair poor contact in main fan motor connector.	Replace main fan motor with a new one.
10	CHECK OPERATION OF SUB FAN MOTOR. Check operation of sub fan motor.	Does the radiator sub fan operate?	Go to step 15.	Go to step 11.
11	CHECK POWER SUPPLY TO SUB FAN MOTOR. CAUTION: Be careful not to overheat engine during repair. 1) Turn ignition switch to OFF. 2) Disconnect connector from sub fan motor. 3) Start the engine, and warm it up until engine coolant temperature increases over 100°C (212°F). 4) Stop the engine and turn ignition switch to ON. 5) Measure voltage between sub fan motor connector and chassis ground. Connector & terminal (F16) No. 1, 2 (+) — Chassis ground (-):	Is the voltage more than 10 V?	Go to step 12.	Repair open circuit in harness for power supply circuit.
12	CHECK GROUND CIRCUIT OF SUB FAN MOTOR. 1) Turn ignition switch to OFF. 2) Measure resistance between sub fan motor connector and chassis ground. Connector & terminal (F16) No. 4 — Chassis ground:	Is the resistance less than 1 Ω?	Go to step 13.	Repair open circuit in harness between sub fan motor connector and chassis ground.
13	CHECK POOR CONTACT. Check poor contact in sub fan motor connector.	Is there poor contact in sub fan motor connector?	Repair poor contact in sub fan motor connector.	Go to step 14.
14	CHECK SUB FAN MOTOR. Connect battery positive (+) terminal to terminal No. 1, 2, and negative (-) terminal to terminal No. 4 of sub fan motor connector.	Does the sub fan rotate?	Repair poor contact in sub fan motor connector.	Replace sub fan motor with a new one.
15	CHECK EACH SENSOR AND POTENTIOMETER. Check the sensors and potentiometer for proper operation using the self-diagnostic function. <Ref. to AC-12, Diagnostics Chart for Diagnosis System.>	Is the operation of each sensor and potentiometer normal?	Go to step 16.	Replace sensor and/or potentiometer.
16	CHECK CONNECTION OF ASPIRATOR DUCT. Make sure that the connection of aspirator duct is correct.	Is the connection of aspirator duct correct?	Repair aspirator duct connection.	Go to step 17.
17	CHECK EACH ACTUATOR. Check the actuators for proper operation using the self-diagnostic function. <Ref. to AC-12, Diagnostics Chart for Diagnosis System.>	Is the operation of each actuator normal?	Go to step 18.	Replace actuator.
18	CHECK POOR CONTACT. Check poor contact in A/C control module.	Is there poor contact in A/C control module?	Repair poor contact in A/C control module.	Contact with SOA (distributor) service.

DIAGNOSTICS FOR A/C SYSTEM FAILURE

HVAC System (Auto A/C) (DIAGNOSTICS)

6. Diagnostics for A/C System Failure S001625

A: A/C AND/OR SELF-DIAGNOSIS SYSTEMS DO NOT OPERATE S001625F37

TROUBLE SYMPTOM:

- "Set" temperature is not indicated on display, switch LEDs are faulty and switches do not operate.
- Self-diagnosis system does not operate.

WIRING DIAGRAM:

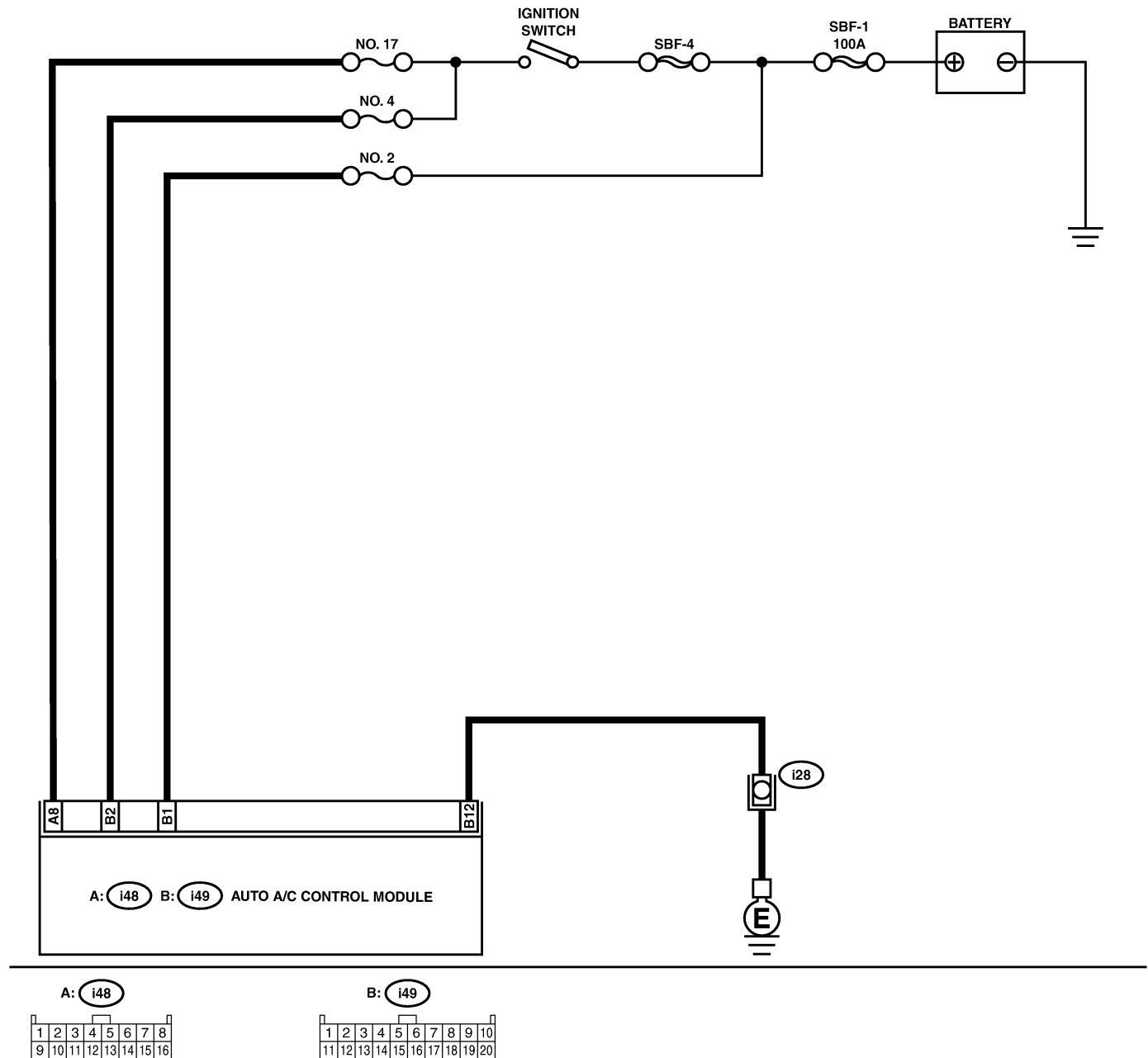

DIAGNOSTICS FOR A/C SYSTEM FAILURE

HVAC System (Auto A/C) (DIAGNOSTICS)

No.	Step	Check	Yes	No
1	CHECK FUSE. 1) Turn ignition switch to OFF. 2) Remove fuse No. 2 from main fuse box. 3) Check condition of fuse.	Is the fuse blown-out?	Replace fuse.	Go to step 2.
2	CHECK FUSE. 1) Turn ignition switch to OFF. 2) Remove fuses No. 4 and No. 17 from joint box. 3) Check condition of fuse.	Is the fuse blown-out?	Replace fuse.	Go to step 3.
3	CHECK A/C CONTROL MODULE POWER CIRCUIT. 1) Pull out A/C control module connector. 2) Measure voltage between A/C control module connector terminal and chassis ground when turning ignition switch to OFF. <i>Connector & terminal</i> <i>(i49) No. 1 (+) — Chassis ground (-):</i>	Is the voltage more than 10 V?	Go to step 4.	Repair short circuit in harness for power supply line.
4	CHECK A/C CONTROL MODULE POWER CIRCUIT. Measure voltage between A/C control module connector terminal and chassis ground when turning ignition switch to ACC. <i>Connector & terminal</i> <i>(i49) No. 2 (+) — Chassis ground (-):</i>	Is the voltage more than 10 V?	Go to step 5.	Repair short circuit in harness for power supply line.
5	CHECK A/C CONTROL MODULE POWER CIRCUIT. Measure voltage between A/C control module connector terminal and chassis ground when turning ignition switch to ON. <i>Connector & terminal</i> <i>(i48) No. 8 (+) — Chassis ground (-):</i>	Is the voltage more than 10 V?	Go to step 6.	Repair short circuit in harness for power supply line.
6	CHECK A/C CONTROL MODULE GROUND CIRCUIT. Measure resistance of harness between A/C control module and chassis ground. <i>Connector & terminal</i> <i>(i49) No. 12 — Chassis ground:</i>	Is the resistance less than 5 Ω ?	Go to step 7.	Repair short circuit in harness for ground line.
7	CHECK POOR CONTACT. Check poor contact in A/C control module.	Is there poor contact in A/C control module?	Repair poor contact in A/C control module.	Contact with SOA (distributor) service.

DIAGNOSTICS FOR A/C SYSTEM FAILURE

HVAC System (Auto A/C) (DIAGNOSTICS)

B: BLOWER MOTOR IS NOT ROTATED S001625F38

TROUBLE SYMPTOM:

- Blower motor is not rotated.
- Blower motor is not rotated in "HI".

WIRING DIAGRAM:

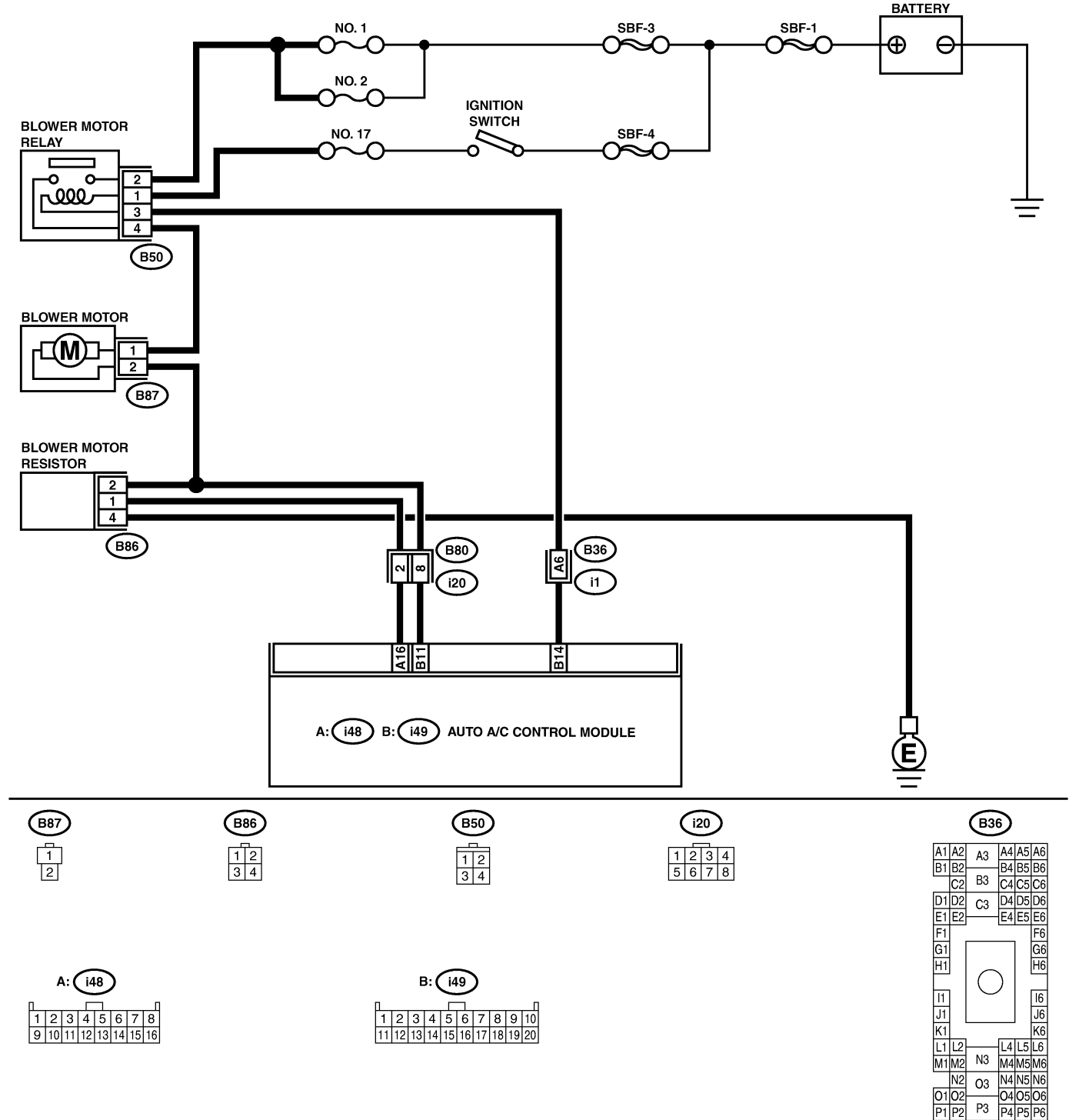

B4M2372

DIAGNOSTICS FOR A/C SYSTEM FAILURE

HVAC System (Auto A/C) (DIAGNOSTICS)

No.	Step	Check	Yes	No
1	CHECK FUSE. 1) Remove No. 2 and No. 17 fuses in joint box. 2) Check condition of fuses.	Are any of the fuses blown-out?	Replace fuse.	Go to step 2.
2	CHECK POWER SUPPLY TO BLOWER FAN MOTOR. 1) Turn ignition switch to ON. 2) Turn blower switch to ON. 3) Measure voltage between blower fan motor and chassis ground. Connector & terminal (B87) No. 1 (+) — Chassis ground (-):	Is the voltage more than 10 V?	Go to step 3.	Repair open circuit in harness for blower fan motor power supply line.
3	CHECK BLOWER FAN MOTOR RELAY. 1) Turn ignition switch to OFF. 2) Remove blower fan motor relay. 3) Connect battery to No. 1 and No. 3 terminals of blower fan motor connector. 4) Measure resistance between No. 2 and No. 4 terminals. Terminals: No. 2 — No. 4	Is the resistance less than 1 Ω ?	Go to step 4.	Replace blower fan motor relay.
4	CHECK BLOWER FAN MOTOR. 1) Disconnect connector from blower fan motor. 2) Connect battery to connector terminals of blower fan motor. 3) Make sure that blower fan motor is operated.	Does the blower fan motor operate?	Go to step 5.	Replace blower fan motor.
5	CHECK POOR CONTACT. Check poor contact in A/C control module.	Is there poor contact in A/C control module?	Repair poor contact in A/C control module.	Contact with SOA (distributor) service.

DIAGNOSTICS FOR A/C SYSTEM FAILURE

HVAC System (Auto A/C) (DIAGNOSTICS)

C: FRESH/RECIRC IS NOT CHANGED S001625F39

TROUBLE SYMPTOM:

FRESH/RECIRC mode door is not changed.

WIRING DIAGRAM:

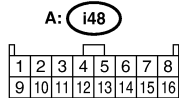
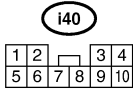
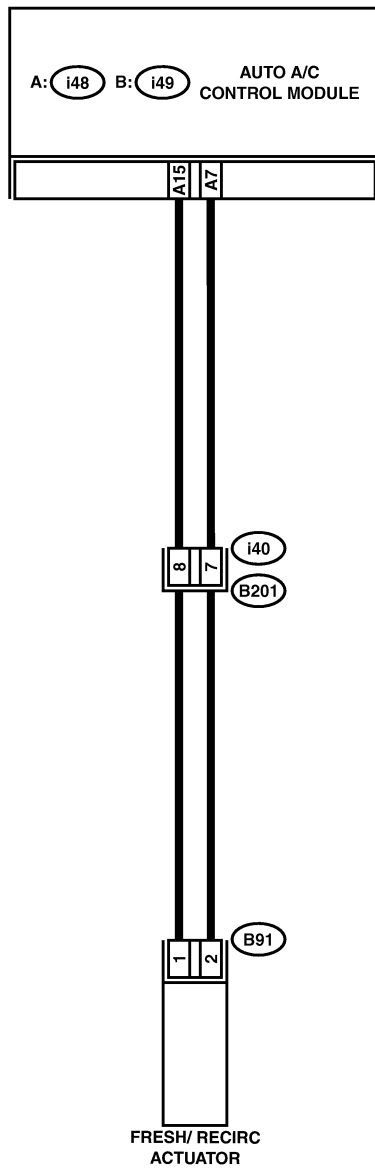

B4M2373

DIAGNOSTICS FOR A/C SYSTEM FAILURE

HVAC System (Auto A/C) (DIAGNOSTICS)

No.	Step	Check	Yes	No
1	CHECK SWITCH OPERATION. Make sure that the mode selection on display is changed when pushing the "MODE" switch.	Does the mode selection change?	Go to step 7.	Go to step 2.
2	CHECK FUSE. 1) Remove No. 17 fuse in joint box. 2) Check condition of fuse.	Is the fuse blown-out?	Replace fuse.	Go to step 3.
3	CHECK SIGNAL VOLTAGE. 1) Change display to RECIRC by pushing MODE switch. 2) Measure voltage between A/C control module and chassis ground. <i>Connector & terminal</i> <i>(i48) No. 15 (+) — Chassis ground (-):</i>	Is the voltage less than 1 V?	Go to step 4.	Repair short circuit in harness for power supply line.
4	CHECK SIGNAL VOLTAGE. 1) Change display to FRESH with pushing MODE switch. 2) Measure voltage between A/C control module and chassis ground. <i>Connector & terminal</i> <i>(i48) No. 7 (+) — Chassis ground (-):</i>	Is the voltage less than 1 V?	Go to step 5.	Repair short circuit in harness for power supply line.
5	CHECK HARNESS CONNECTOR BETWEEN A/C CONTROL MODULE AND FRESH/RECIRC ACTUATOR. 1) Turn ignition switch to OFF. 2) Disconnect connector from A/C control module and mode door motor. 3) Measure resistance of harness between A/C control module and FRESH/RECIRC actuator. <i>Connector & terminal:</i> <i>(i48) No. 15 — (B91) No. 1</i>	Is the resistance less than 1 Ω ?	Go to step 6.	Repair open circuit in harness between A/C control module and FRESH/RECIRC actuator.
6	CHECK HARNESS CONNECTOR BETWEEN A/C CONTROL MODULE AND FRESH/RECIRC ACTUATOR. Measure resistance of harness between A/C control module and FRESH/RECIRC actuator. <i>Connector & terminal:</i> <i>(i48) No. 7 — (B91) No. 2</i>	Is the resistance less than 1 Ω ?	Go to step 7.	Repair open circuit in harness between A/C control module and FRESH/RECIRC actuator.
7	CHECK POOR CONTACT. Check poor contact in A/C control module.	Is there poor contact in A/C control module?	Repair poor contact in A/C control module.	Contact with SOA (distributor) service.

DIAGNOSTICS FOR A/C SYSTEM FAILURE

HVAC System (Auto A/C) (DIAGNOSTICS)

D: COMPARTMENT TEMPERATURE IS NOT CHANGED OR A/C SYSTEM DOES NOT RESPOND QUICKLY

S001625F40

WIRING DIAGRAM:

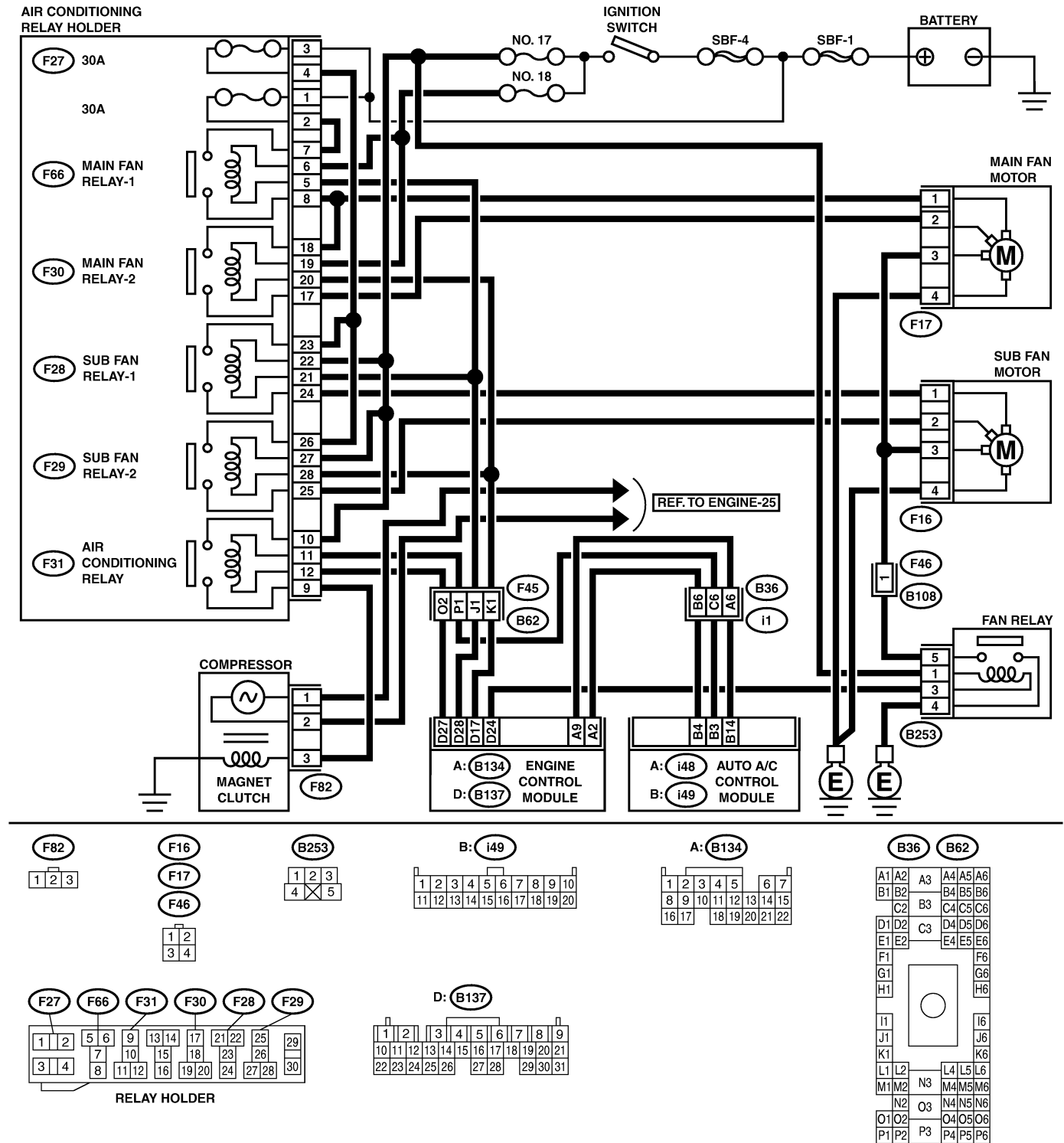

B4M2374

DIAGNOSTICS FOR A/C SYSTEM FAILURE

HVAC System (Auto A/C) (DIAGNOSTICS)

No.	Step	Check	Yes	No
1	CHECK FUSE. 1) Turn ignition switch to OFF. 2) Remove No. 2 fuse in main fuse box. 3) Check condition of fuse.	Is the fuse blown-out?	Replace fuse.	Go to step 2.
2	CHECK POWER SUPPLY TO MAGNET CLUTCH OF A/C COMPRESSOR. 1) Start the engine, and turn A/C switch to ON. 2) Set the compartment temperature at 18°C (65°F) (MAX COOL). 3) Measure voltage between magnet clutch connector and chassis ground. Connector & terminal (F82) No. 3 (+) — Chassis ground (-):	Is the voltage more than 10 V?	Go to step 3.	Repair open circuit in harness for power supply line of the A/C compressor.
3	CHECK SIGNAL VOLTAGE TO A/C RELAY. 1) Turn ignition switch to ON. 2) Turn A/C switch to ON. 3) Measure signal voltage to A/C relay and chassis ground. Connector & terminal (F31) No. 9 (+) — Chassis ground (-):	Is the voltage more than 10 V?	Go to step 4.	Repair open circuit in harness for power supply line.
4	CHECK A/C RELAY. 1) Remove A/C relay in main fuse box. 2) Check A/C relay. <Ref. to AC-40, INSPECTION, Relay and Fuse.>	Is the operation of each relay OK?	Go to step 5.	Replace A/C relay.
5	CHECK OPERATION OF MAIN FAN MOTOR. 1) Start the engine. 2) Turn A/C switch to ON. 3) Check operation of main fan motor.	Does the radiator main fan operate?	Go to step 10.	Go to step 6.
6	CHECK POWER SUPPLY TO MAIN FAN MOTOR. CAUTION: Be careful not to overheat engine during repair. 1) Turn ignition switch to OFF. 2) Disconnect connector from main fan motor. 3) Start the engine, and warm it up until engine coolant temperature increases over 95°C (203°F). 4) Stop the engine and turn ignition switch to ON. 5) Measure voltage between main fan motor connector and chassis ground. Connector & terminal (F17) No. 1, 2 (+) — Chassis ground (-):	Is the voltage more than 10 V?	Go to step 7.	Repair open circuit in harness for power supply circuit.
7	CHECK GROUND CIRCUIT OF MAIN FAN MOTOR. 1) Turn ignition switch to OFF. 2) Measure resistance between main fan motor connector and chassis ground. Connector & terminal (F17) No. 4 — Chassis ground:	Is the resistance less than 1 Ω?	Go to step 8.	Repair open circuit in harness between main fan motor connector and chassis ground.
8	CHECK POOR CONTACT. Check poor contact in main fan motor connector.	Is there poor contact in main fan motor connector?	Repair poor contact in main fan motor connector.	Go to step 9.

DIAGNOSTICS FOR A/C SYSTEM FAILURE

HVAC System (Auto A/C) (DIAGNOSTICS)

No.	Step	Check	Yes	No
9	CHECK MAIN FAN MOTOR. Connect battery positive (+) terminal to terminal No. 1, 2, and negative (-) terminal to terminal No. 4 of main fan motor connector.	Does the main fan rotate?	Repair poor contact in main fan motor connector.	Replace main fan motor with a new one.
10	CHECK OPERATION OF SUB FAN MOTOR. Check operation of sub fan motor.	Does the radiator sub fan operate?	Go to step 15.	Go to step 11.
11	CHECK POWER SUPPLY TO SUB FAN MOTOR. CAUTION: Be careful not to overheat engine during repair. 1) Turn ignition switch to OFF. 2) Disconnect connector from sub fan motor. 3) Start the engine, and warm it up until engine coolant temperature increases over 100°C (212°F). 4) Stop the engine and turn ignition switch to ON. 5) Measure voltage between sub fan motor connector and chassis ground. Connector & terminal (F16) No. 1, 2 (+) — Chassis ground (-):	Is the voltage more than 10 V?	Go to step 12.	Repair open circuit in harness for power supply circuit.
12	CHECK GROUND CIRCUIT OF SUB FAN MOTOR. 1) Turn ignition switch to OFF. 2) Measure resistance between sub fan motor connector and chassis ground. Connector & terminal (F16) No. 4 — Chassis ground:	Is the resistance less than 1 Ω?	Go to step 13.	Repair open circuit in harness between sub fan motor connector and chassis ground.
13	CHECK POOR CONTACT. Check poor contact in sub fan motor connector.	Is there poor contact in sub fan motor connector?	Repair poor contact in sub fan motor connector.	Go to step 14.
14	CHECK SUB FAN MOTOR. Connect battery positive (+) terminal to terminal No. 1, 2, and negative (-) terminal to terminal No. 4 of sub fan motor connector.	Does the sub fan rotate?	Repair poor contact in sub fan motor connector.	Replace sub fan motor with a new one.
15	CHECK EACH SENSOR AND POTENTIOMETER. Check the sensors and potentiometer for proper operation using the self-diagnostic function. <Ref. to AC-12, Diagnostics Chart for Diagnosis System.>	Is the operation of each sensor and potentiometer normal?	Go to step 16.	Replace sensor and/or potentiometer.
16	CHECK CONNECTION OF ASPIRATOR DUCT. Make sure that the connection of aspirator duct is correct.	Is the connection of aspirator duct correct?	Repair aspirator duct connection.	Go to step 17.
17	CHECK EACH ACTUATOR. Check the actuators for proper operation using the self-diagnostic function. <Ref. to AC-12, Diagnostics Chart for Diagnosis System.>	Is the operation of each actuator normal?	Go to step 18.	Replace actuator.
18	CHECK POOR CONTACT. Check poor contact in A/C control module.	Is there poor contact in A/C control module?	Repair poor contact in A/C control module.	Contact with SOA (distributor) service.

LIST OF DIAGNOSTIC TROUBLE CODE

HVAC System (Auto A/C) (DIAGNOSTICS)

7. List of Diagnostic Trouble Code S001511

A: LIST S001511A12

1. TROUBLE CODE FOR SENSOR AND POTENTIOMETER S001511A1201

Trouble Code	Trouble Unit	Contents
20	No Trouble	—
21	Ambient sensor	Open
-21		Short
22	In-vehicle sensor	Open
-22		Short
24	Evaporation sensor	Open
-24		Short
25	Sunload sensor	Open
-25		Short
26	Air mix door motor	Open
-26		Short

2. TROUBLE CODE FOR MODE DOOR POSITION SWITCH S001511A1202

Trouble Code	30	31	32	33	34	35
Faulty Door	No Trouble	VENT	B/L	HEAT	D/H	DEF

LIST OF DIAGNOSTIC TROUBLE CODE

HVAC System (Auto A/C) (DIAGNOSTICS)

7. List of Diagnostic Trouble Code S001511

A: LIST S001511A12

1. TROUBLE CODE FOR SENSOR AND POTENTIOMETER S001511A1201

Trouble Code	Trouble Unit	Contents
20	No Trouble	—
21	Ambient sensor	Open
-21		Short
22	In-vehicle sensor	Open
-22		Short
24	Evaporation sensor	Open
-24		Short
25	Sunload sensor	Open
-25		Short
26	Air mix door motor	Open
-26		Short

2. TROUBLE CODE FOR MODE DOOR POSITION SWITCH S001511A1202

Trouble Code	30	31	32	33	34	35
Faulty Door	No Trouble	VENT	B/L	HEAT	D/H	DEF

DIAGNOSTIC PROCEDURE WITH TROUBLE CODE

HVAC System (Auto A/C) (DIAGNOSTICS)

8. Diagnostic Procedure with Trouble Code S001509

A: TROUBLE CODE 21 OR -21 (AMBIENT SENSOR) S001509F41

TROUBLE SYMPTOM:

Fan speed, outlets and inlets are not switched when AUTO or ECON switch is ON.

WIRING DIAGRAM:

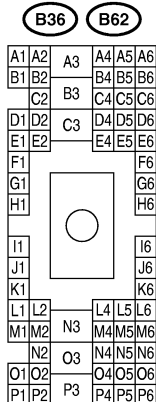
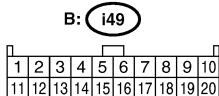
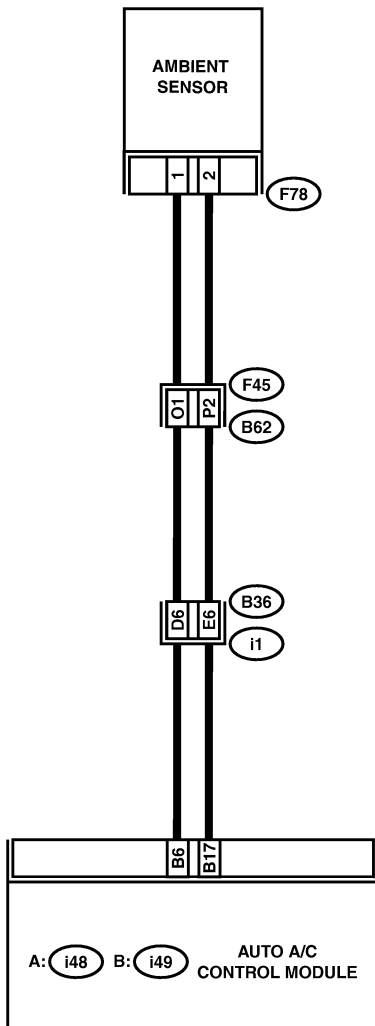

DIAGNOSTIC PROCEDURE WITH TROUBLE CODE

HVAC System (Auto A/C) (DIAGNOSTICS)

No.	Step	Check	Yes	No
1	CHECK AMBIENT SENSOR. 1) Turn ignition switch to OFF. 2) Disconnect connector from ambient sensor. 3) Measure resistance between connector terminals of ambient sensor. <i>Terminals:</i> <i>No. 1 — No. 2</i>	Is the resistance approx. 2.2 k Ω at 25°C (77°F)?	Go to step 2.	Replace ambient sensor.
2	CHECK INPUT SIGNALS FOR AMBIENT SENSOR. 1) Turn ignition ON. 2) Measure voltage between (F78) connector terminals. <i>Connector & terminal:</i> <i>(F78) No. 1 — No. 2</i>	Is the voltage approx. 4.5 V?	Go to step 6.	Go to step 3.
3	CHECK OUTPUT SIGNALS FROM A/C CONTROL MODULE. 1) Turn ignition switch to OFF. 2) Pull out A/C control panel. 3) Disconnect connector from ambient sensor. 4) Turn ignition switch to ON. 5) Measure voltage between connector terminals of A/C control module. <i>Connector & terminal:</i> <i>(i49) No. 6 — No. 17</i>	Is the voltage approx. 4.5 V?	Go to step 6.	Go to step 4.
4	CHECK HARNESS CONNECTOR BETWEEN A/C CONTROL MODULE AND AMBIENT SENSOR. 1) Turn ignition switch to OFF. 2) Disconnect connectors from A/C control module. 3) Measure resistance of harness between A/C control module and ambient sensor. <i>Connector & terminal:</i> <i>(F78) No. 1 — (i49) No. 6</i>	Is the resistance less than 1 Ω ?	Go to step 5.	Repair open circuit in harness between A/C control module and ambient sensor.
5	CHECK HARNESS CONNECTOR BETWEEN A/C CONTROL MODULE AND AMBIENT SENSOR. Measure resistance of harness between A/C control module and ambient sensor. <i>Connector & terminal:</i> <i>(F78) No. 2 — (i49) No. 17</i>	Is the resistance less than 1 Ω ?	Go to step 6.	Repair open circuit in harness between A/C control module and ambient sensor.
6	CHECK POOR CONTACT. Check poor contact in A/C control module.	Is there poor contact in A/C control module?	Repair poor contact in A/C control module.	Contact with SOA (distributor) service.

DIAGNOSTIC PROCEDURE WITH TROUBLE CODE

HVAC System (Auto A/C) (DIAGNOSTICS)

B: TROUBLE CODE 22 OR -22 (IN-VEHICLE SENSOR) S001509F42

TROUBLE SYMPTOM:

When turning AUTO switch to ON, blower fan speed, outlet port and inlet port is not changed.

If trouble code 22 or -22 appears on the display, replace the A/C control module. The in-vehicle sensor is built into the A/C control module and cannot be replaced as a single unit.

DIAGNOSTIC PROCEDURE WITH TROUBLE CODE

HVAC System (Auto A/C) (DIAGNOSTICS)

MEMO:

DIAGNOSTIC PROCEDURE WITH TROUBLE CODE

HVAC System (Auto A/C) (DIAGNOSTICS)

C: TROUBLE CODE 24 OR -24 (EVAPORATOR SENSOR) S001509F43

WIRING DIAGRAM:

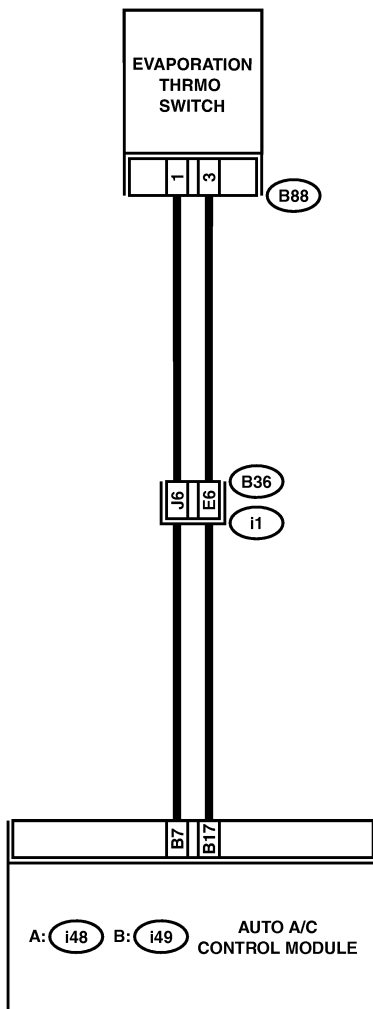

B88

1
2
3

B: i49

1	2	3	4	5	6	7	8	9	10
11	12	13	14	15	16	17	18	19	20

B36

A1	A2	A3	A4	A5	A6
B1	B2	B3	B4	B5	B6
C1	C2	C3	C4	C5	C6
D1	D2	D3	D4	D5	D6
E1	E2	E3	E4	E5	E6
F1	F2	F3	F4	F5	F6
G1	G2	G3	G4	G5	G6
H1	H2	H3	H4	H5	H6
I1	I2	I3	I4	I5	I6
J1	J2	J3	J4	J5	J6
K1	K2	K3	K4	K5	K6
L1	L2	L3	L4	L5	L6
M1	M2	M3	M4	M5	M6
N1	N2	N3	N4	N5	N6
O1	O2	O3	O4	O5	O6
P1	P2	P3	P4	P5	P6

B4M2376

DIAGNOSTIC PROCEDURE WITH TROUBLE CODE

HVAC System (Auto A/C) (DIAGNOSTICS)

No.	Step	Check	Yes	No
1	<p>CHECK EVAPORATOR SENSOR.</p> <p>1) Turn ignition switch to OFF. 2) Remove glove box. 3) Disconnect connector from evaporator sensor. 4) Measure resistance between connector terminals of evaporator sensor.</p> <p>Terminals: No. 1 — No. 3</p>	Is the resistance approx. 1.8 — 2.0 k Ω at 20°C (68°F)?	Go to step 2.	Replace evaporator sensor.
2	<p>CHECK INPUT SIGNALS FOR EVAPORATOR SENSOR.</p> <p>1) Turn ignition switch to "ON". 2) Measure voltage between (B88) connector terminal and chassis ground.</p> <p>Connector & terminal (B88) No. 1 (+) — Chassis ground (-):</p>	Is the voltage approx. 4.5 V?	Go to step 3.	Replace evaporator sensor.
3	<p>CHECK OUTPUT SIGNALS FROM A/C CONTROL MODULE.</p> <p>1) Turn ignition switch to OFF. 2) Pull out A/C control module. 3) Turn ignition switch to "ON". 4) Measure voltage between A/C control module connector terminals.</p> <p>Connector & terminal: (i49) No. 7 — No. 17</p>	Is the voltage approx. 4.5 V?	Go to step 4.	Go to step 6.
4	<p>CHECK HARNESS CONNECTOR BETWEEN A/C CONTROL MODULE AND EVAPORATOR SENSOR.</p> <p>1) Turn ignition switch to OFF. 2) Disconnect connectors from A/C control module. 3) Measure resistance of harness between A/C control module and evaporator sensor.</p> <p>Connector & terminal: (B88) No. 1 — (i49) No. 7</p>	Is the resistance less than 1 Ω ?	Go to step 5.	Repair open circuit in harness between A/C control module and evaporator sensor.
5	<p>CHECK HARNESS CONNECTOR BETWEEN A/C CONTROL MODULE AND EVAPORATOR SENSOR.</p> <p>Measure resistance of harness between A/C control module and evaporator sensor.</p> <p>Connector & terminal: (B88) No. 3 — (i49) No. 17</p>	Is the resistance less than 1 Ω ?	Go to step 6.	Repair open circuit in harness between A/C control module and evaporator sensor.
6	<p>CHECK POOR CONTACT.</p> <p>Check poor contact in A/C control module.</p>	Is there poor contact in A/C control module?	Repair poor contact in A/C control module.	Contact with SOA (distributor) service.

DIAGNOSTIC PROCEDURE WITH TROUBLE CODE

HVAC System (Auto A/C) (DIAGNOSTICS)

D: TROUBLE CODE 25 OR -25 (SUNLOAD SENSOR) S001509F44

TROUBLE SYMPTOM:

- Sensor identified that sunlight is at maximum. Then, A/C system is controlled to COOL side.
- Sensor identified that sunlight is at minimum. Then, A/C system is controlled to HOT side.

NOTE:

When the sunload sensor is checked inside the passenger compartment or in the shade, code "25" may appear on the indicator. Always check the sunload sensor in a place where it senses direct sunlight.

DIAGNOSTIC PROCEDURE WITH TROUBLE CODE

HVAC System (Auto A/C) (DIAGNOSTICS)

WIRING DIAGRAM:

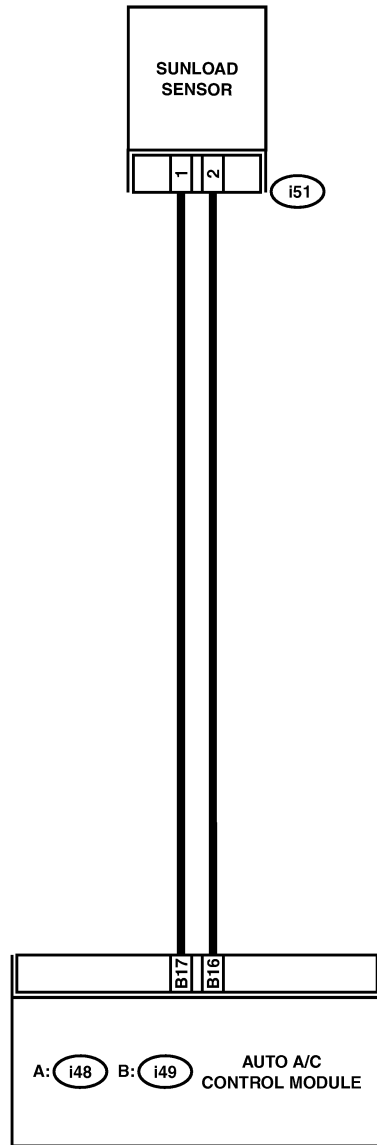

i51

1 2

B: i49

1	2	3	4	5	6	7	8	9	10
11	12	13	14	15	16	17	18	19	20

B4M2377

DIAGNOSTIC PROCEDURE WITH TROUBLE CODE

HVAC System (Auto A/C) (DIAGNOSTICS)

No.	Step	Check	Yes	No
1	CHECK SUNLOAD SENSOR. 1) Turn ignition switch to OFF. 2) Remove sunload sensor. <Ref. to AC-44, REMOVAL, Sun-load Sensor (Auto A/C).> 3) Measure resistance between sunload sensor terminals. Terminals: No. 2 — No. 1	Is the resistance less than 1 Ω?	Go to step 2.	Replace sunload sensor.
2	CHECK SUNLOAD SENSOR. Make sure that there is no resistance in the reverse side terminals. Terminals: No. 1 — No. 2	Is the resistance more than 1 MΩ?	Go to step 3.	Replace sunload sensor.
3	CHECK INPUT VOLTAGE TO SUNLOAD SENSOR. 1) Turn ignition switch to ON. 2) Measure input voltage to sunload sensor. Connector & terminal: (i51) No. 2 — No. 1	Is the voltage approx. 4.5 V?	Go to step 6.	Go to step 4.
4	CHECK HARNESS CONNECTOR BETWEEN A/C CONTROL MODULE AND SUNLOAD SENSOR. 1) Turn ignition switch to OFF. 2) Disconnect connectors from A/C control module. 3) Measure resistance of harness between A/C control module and sunload sensor. Connector & terminal: (i51) No. 2 — (i49) No. 16	Is the resistance less than 1 Ω?	Go to step 5.	Repair open circuit in harness between A/C control module and sunload sensor.
5	CHECK HARNESS CONNECTOR BETWEEN A/C CONTROL MODULE AND SUNLOAD SENSOR. Measure resistance of harness between A/C control module and sunload sensor. Connector & terminal: (i51) No. 1 — (i49) No. 17	Is the resistance less than 1 Ω?	Go to step 6.	Repair open circuit in harness between A/C control module and sunload sensor.
6	CHECK POOR CONTACT. Check poor contact in A/C control module.	Is there poor contact in A/C control module?	Repair poor contact in A/C control module.	Contact with SOA (distributor) service.

DIAGNOSTIC PROCEDURE WITH TROUBLE CODE

HVAC System (Auto A/C) (DIAGNOSTICS)

8. Diagnostic Procedure with Trouble Code S001509

A: TROUBLE CODE 21 OR -21 (AMBIENT SENSOR) S001509F41

TROUBLE SYMPTOM:

Fan speed, outlets and inlets are not switched when AUTO or ECON switch is ON.

WIRING DIAGRAM:

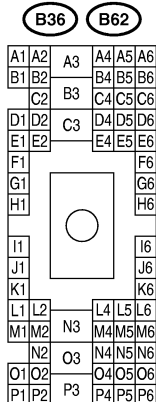
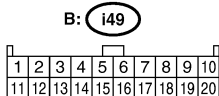
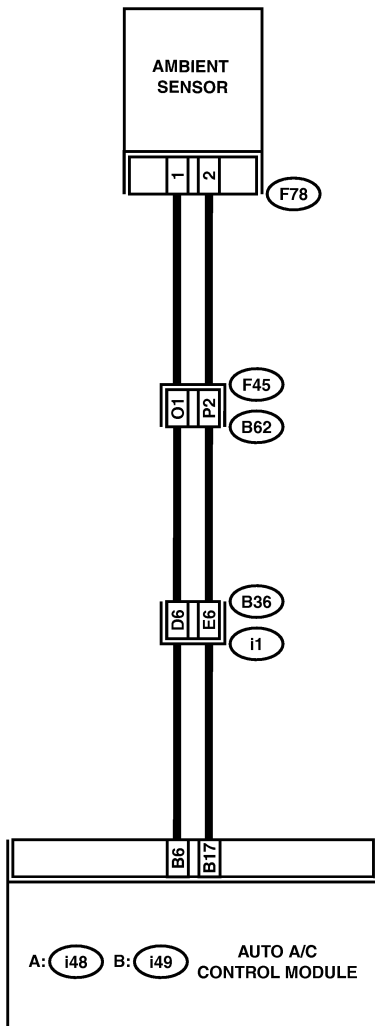

DIAGNOSTIC PROCEDURE WITH TROUBLE CODE

HVAC System (Auto A/C) (DIAGNOSTICS)

No.	Step	Check	Yes	No
1	CHECK AMBIENT SENSOR. 1) Turn ignition switch to OFF. 2) Disconnect connector from ambient sensor. 3) Measure resistance between connector terminals of ambient sensor. <i>Terminals:</i> <i>No. 1 — No. 2</i>	Is the resistance approx. 2.2 k Ω at 25°C (77°F)?	Go to step 2.	Replace ambient sensor.
2	CHECK INPUT SIGNALS FOR AMBIENT SENSOR. 1) Turn ignition ON. 2) Measure voltage between (F78) connector terminals. <i>Connector & terminal:</i> <i>(F78) No. 1 — No. 2</i>	Is the voltage approx. 4.5 V?	Go to step 6.	Go to step 3.
3	CHECK OUTPUT SIGNALS FROM A/C CONTROL MODULE. 1) Turn ignition switch to OFF. 2) Pull out A/C control panel. 3) Disconnect connector from ambient sensor. 4) Turn ignition switch to ON. 5) Measure voltage between connector terminals of A/C control module. <i>Connector & terminal:</i> <i>(i49) No. 6 — No. 17</i>	Is the voltage approx. 4.5 V?	Go to step 6.	Go to step 4.
4	CHECK HARNESS CONNECTOR BETWEEN A/C CONTROL MODULE AND AMBIENT SENSOR. 1) Turn ignition switch to OFF. 2) Disconnect connectors from A/C control module. 3) Measure resistance of harness between A/C control module and ambient sensor. <i>Connector & terminal:</i> <i>(F78) No. 1 — (i49) No. 6</i>	Is the resistance less than 1 Ω ?	Go to step 5.	Repair open circuit in harness between A/C control module and ambient sensor.
5	CHECK HARNESS CONNECTOR BETWEEN A/C CONTROL MODULE AND AMBIENT SENSOR. Measure resistance of harness between A/C control module and ambient sensor. <i>Connector & terminal:</i> <i>(F78) No. 2 — (i49) No. 17</i>	Is the resistance less than 1 Ω ?	Go to step 6.	Repair open circuit in harness between A/C control module and ambient sensor.
6	CHECK POOR CONTACT. Check poor contact in A/C control module.	Is there poor contact in A/C control module?	Repair poor contact in A/C control module.	Contact with SOA (distributor) service.

DIAGNOSTIC PROCEDURE WITH TROUBLE CODE

HVAC System (Auto A/C) (DIAGNOSTICS)

B: TROUBLE CODE 22 OR -22 (IN-VEHICLE SENSOR) S001509F42

TROUBLE SYMPTOM:

When turning AUTO switch to ON, blower fan speed, outlet port and inlet port is not changed.

If trouble code 22 or -22 appears on the display, replace the A/C control module. The in-vehicle sensor is built into the A/C control module and cannot be replaced as a single unit.

DIAGNOSTIC PROCEDURE WITH TROUBLE CODE

HVAC System (Auto A/C) (DIAGNOSTICS)

MEMO:

DIAGNOSTIC PROCEDURE WITH TROUBLE CODE

HVAC System (Auto A/C) (DIAGNOSTICS)

C: TROUBLE CODE 24 OR -24 (EVAPORATOR SENSOR) S001509F43

WIRING DIAGRAM:

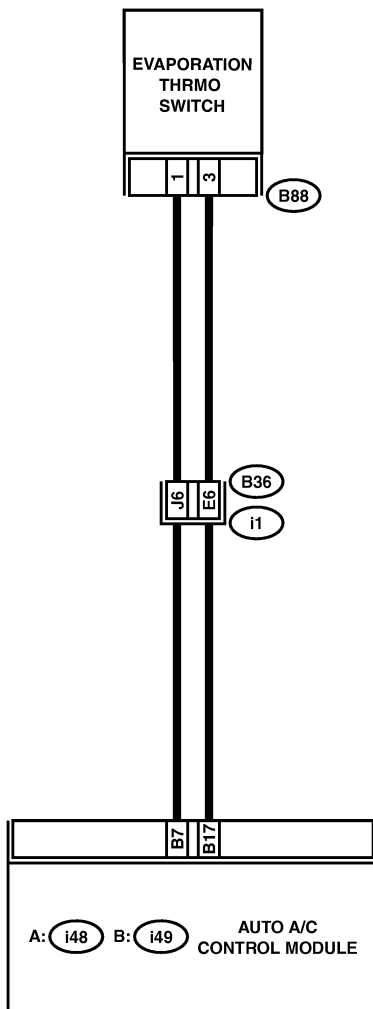

B88



B: i49

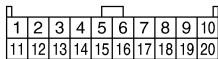

B36

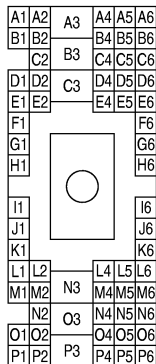

B4M2376

DIAGNOSTIC PROCEDURE WITH TROUBLE CODE

HVAC System (Auto A/C) (DIAGNOSTICS)

No.	Step	Check	Yes	No
1	<p>CHECK EVAPORATOR SENSOR.</p> <p>1) Turn ignition switch to OFF. 2) Remove glove box. 3) Disconnect connector from evaporator sensor. 4) Measure resistance between connector terminals of evaporator sensor.</p> <p>Terminals: No. 1 — No. 3</p>	Is the resistance approx. 1.8 — 2.0 k Ω at 20°C (68°F)?	Go to step 2.	Replace evaporator sensor.
2	<p>CHECK INPUT SIGNALS FOR EVAPORATOR SENSOR.</p> <p>1) Turn ignition switch to "ON". 2) Measure voltage between (B88) connector terminal and chassis ground.</p> <p>Connector & terminal (B88) No. 1 (+) — Chassis ground (-):</p>	Is the voltage approx. 4.5 V?	Go to step 3.	Replace evaporator sensor.
3	<p>CHECK OUTPUT SIGNALS FROM A/C CONTROL MODULE.</p> <p>1) Turn ignition switch to OFF. 2) Pull out A/C control module. 3) Turn ignition switch to "ON". 4) Measure voltage between A/C control module connector terminals.</p> <p>Connector & terminal: (i49) No. 7 — No. 17</p>	Is the voltage approx. 4.5 V?	Go to step 4.	Go to step 6.
4	<p>CHECK HARNESS CONNECTOR BETWEEN A/C CONTROL MODULE AND EVAPORATOR SENSOR.</p> <p>1) Turn ignition switch to OFF. 2) Disconnect connectors from A/C control module. 3) Measure resistance of harness between A/C control module and evaporator sensor.</p> <p>Connector & terminal: (B88) No. 1 — (i49) No. 7</p>	Is the resistance less than 1 Ω ?	Go to step 5.	Repair open circuit in harness between A/C control module and evaporator sensor.
5	<p>CHECK HARNESS CONNECTOR BETWEEN A/C CONTROL MODULE AND EVAPORATOR SENSOR.</p> <p>Measure resistance of harness between A/C control module and evaporator sensor.</p> <p>Connector & terminal: (B88) No. 3 — (i49) No. 17</p>	Is the resistance less than 1 Ω ?	Go to step 6.	Repair open circuit in harness between A/C control module and evaporator sensor.
6	<p>CHECK POOR CONTACT.</p> <p>Check poor contact in A/C control module.</p>	Is there poor contact in A/C control module?	Repair poor contact in A/C control module.	Contact with SOA (distributor) service.

DIAGNOSTIC PROCEDURE WITH TROUBLE CODE

HVAC System (Auto A/C) (DIAGNOSTICS)

D: TROUBLE CODE 25 OR -25 (SUNLOAD SENSOR) S001509F44

TROUBLE SYMPTOM:

- Sensor identified that sunlight is at maximum. Then, A/C system is controlled to COOL side.
- Sensor identified that sunlight is at minimum. Then, A/C system is controlled to HOT side.

NOTE:

When the sunload sensor is checked inside the passenger compartment or in the shade, code "25" may appear on the indicator. Always check the sunload sensor in a place where it senses direct sunlight.

DIAGNOSTIC PROCEDURE WITH TROUBLE CODE

HVAC System (Auto A/C) (DIAGNOSTICS)

WIRING DIAGRAM:

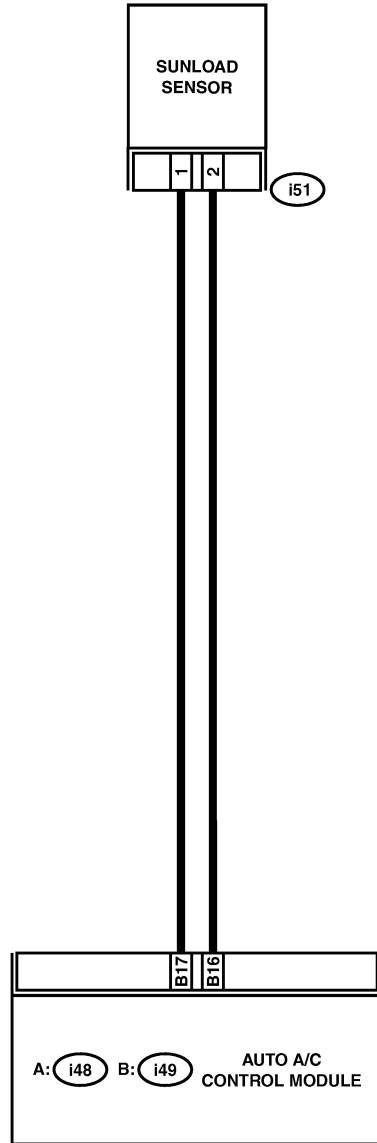

i51

1	2
---	---

B: i49

1	2	3	4	5	6	7	8	9	10
11	12	13	14	15	16	17	18	19	20

B4M2377

DIAGNOSTIC PROCEDURE WITH TROUBLE CODE

HVAC System (Auto A/C) (DIAGNOSTICS)

No.	Step	Check	Yes	No
1	<p>CHECK SUNLOAD SENSOR. 1) Turn ignition switch to OFF. 2) Remove sunload sensor. <Ref. to AC-44, REMOVAL, Sun-load Sensor (Auto A/C).> 3) Measure resistance between sunload sensor terminals. Terminals: No. 2 — No. 1</p>	Is the resistance less than 1 Ω?	Go to step 2.	Replace sunload sensor.
2	<p>CHECK SUNLOAD SENSOR. Make sure that there is no resistance in the reverse side terminals. Terminals: No. 1 — No. 2</p>	Is the resistance more than 1 MΩ?	Go to step 3.	Replace sunload sensor.
3	<p>CHECK INPUT VOLTAGE TO SUNLOAD SENSOR. 1) Turn ignition switch to ON. 2) Measure input voltage to sunload sensor. Connector & terminal: (i51) No. 2 — No. 1</p>	Is the voltage approx. 4.5 V?	Go to step 6.	Go to step 4.
4	<p>CHECK HARNESS CONNECTOR BETWEEN A/C CONTROL MODULE AND SUNLOAD SENSOR. 1) Turn ignition switch to OFF. 2) Disconnect connectors from A/C control module. 3) Measure resistance of harness between A/C control module and sunload sensor. Connector & terminal: (i51) No. 2 — (i49) No. 16</p>	Is the resistance less than 1 Ω?	Go to step 5.	Repair open circuit in harness between A/C control module and sunload sensor.
5	<p>CHECK HARNESS CONNECTOR BETWEEN A/C CONTROL MODULE AND SUNLOAD SENSOR. Measure resistance of harness between A/C control module and sunload sensor. Connector & terminal: (i51) No. 1 — (i49) No. 17</p>	Is the resistance less than 1 Ω?	Go to step 6.	Repair open circuit in harness between A/C control module and sunload sensor.
6	<p>CHECK POOR CONTACT. Check poor contact in A/C control module.</p>	Is there poor contact in A/C control module?	Repair poor contact in A/C control module.	Contact with SOA (distributor) service.

SYMPTOM RELATED DIAGNOSTIC

HVAC System (Auto A/C) (DIAGNOSTICS)

9. Symptom Related Diagnostic S001519

A: GENERAL DIAGNOSTICS TABLE S001519F45

Symptom	A/C system fails to operate when IG SW is turned "ON" .	Burned-out fuse.	Previous mode immediately before resetting operation is not retained in memory.	No indication appears on display.	Illumination does not dim at night.	Blower motor does not rotate or rotates erroneously.	A/C does not change from "Fresh" to "Recirc" or vice versa.	Air vents cannot be switched.	Compartment temperature does not increase (No hot air is discharged).	Compartment temperature does not decrease (No cool air is discharged).	Compartment temperature is higher than or lower than the set value.	Compartment temperature does not quickly respond to the set value.	Condenser fan does not operate during A/C operation.			
Component parts																
Fuses (M/B No. 5, F/B No. 17)	<input type="radio"/>	<input type="radio"/>	<input type="radio"/>	<input type="radio"/>	<input type="radio"/>	<input type="radio"/>	<input type="radio"/>	<input type="radio"/>	<input type="radio"/>	<input type="radio"/>	<input type="radio"/>	<input type="radio"/>	<input type="radio"/>	<input type="radio"/>	<input type="radio"/>	<input type="radio"/>
Poor connector contacts	<input type="radio"/>	<input type="radio"/>	<input type="radio"/>	<input type="radio"/>	<input type="radio"/>	<input type="radio"/>	<input type="radio"/>	<input type="radio"/>	<input type="radio"/>	<input type="radio"/>	<input type="radio"/>	<input type="radio"/>	<input type="radio"/>	<input type="radio"/>	<input type="radio"/>	<input type="radio"/>
Ground	<input type="radio"/>	<input type="radio"/>	<input type="radio"/>	<input type="radio"/>	<input type="radio"/>	<input type="radio"/>	<input type="radio"/>	<input type="radio"/>	<input type="radio"/>	<input type="radio"/>	<input type="radio"/>	<input type="radio"/>	<input type="radio"/>	<input type="radio"/>	<input type="radio"/>	<input type="radio"/>
A/C control module	<input type="radio"/>	<input type="radio"/>	<input type="radio"/>	<input type="radio"/>	<input type="radio"/>	<input type="radio"/>	<input type="radio"/>	<input type="radio"/>	<input type="radio"/>	<input type="radio"/>	<input type="radio"/>	<input type="radio"/>	<input type="radio"/>	<input type="radio"/>	<input type="radio"/>	<input type="radio"/>
Air mix servo motor and potentiometer (including links)	<input type="radio"/>	<input type="radio"/>	<input type="radio"/>	<input type="radio"/>	<input type="radio"/>	<input type="radio"/>	<input type="radio"/>	<input type="radio"/>	<input type="radio"/>	<input type="radio"/>	<input type="radio"/>	<input type="radio"/>	<input type="radio"/>	<input type="radio"/>	<input type="radio"/>	<input type="radio"/>
Air vent select servo motor and potentiometer (including links)	<input type="radio"/>	<input type="radio"/>	<input type="radio"/>	<input type="radio"/>	<input type="radio"/>	<input type="radio"/>	<input type="radio"/>	<input type="radio"/>	<input type="radio"/>	<input type="radio"/>	<input type="radio"/>	<input type="radio"/>	<input type="radio"/>	<input type="radio"/>	<input type="radio"/>	<input type="radio"/>
Fresh-Recirc select servo motor and potentiometer (including links)	<input type="radio"/>	<input type="radio"/>	<input type="radio"/>	<input type="radio"/>	<input type="radio"/>	<input type="radio"/>	<input type="radio"/>	<input type="radio"/>	<input type="radio"/>	<input type="radio"/>	<input type="radio"/>	<input type="radio"/>	<input type="radio"/>	<input type="radio"/>	<input type="radio"/>	<input type="radio"/>
Blower fan motor	<input type="radio"/>	<input type="radio"/>	<input type="radio"/>	<input type="radio"/>	<input type="radio"/>	<input type="radio"/>	<input type="radio"/>	<input type="radio"/>	<input type="radio"/>	<input type="radio"/>	<input type="radio"/>	<input type="radio"/>	<input type="radio"/>	<input type="radio"/>	<input type="radio"/>	<input type="radio"/>
Power transistor & fuse	<input type="radio"/>	<input type="radio"/>	<input type="radio"/>	<input type="radio"/>	<input type="radio"/>	<input type="radio"/>	<input type="radio"/>	<input type="radio"/>	<input type="radio"/>	<input type="radio"/>	<input type="radio"/>	<input type="radio"/>	<input type="radio"/>	<input type="radio"/>	<input type="radio"/>	<input type="radio"/>
Blower fan relay	<input type="radio"/>	<input type="radio"/>	<input type="radio"/>	<input type="radio"/>	<input type="radio"/>	<input type="radio"/>	<input type="radio"/>	<input type="radio"/>	<input type="radio"/>	<input type="radio"/>	<input type="radio"/>	<input type="radio"/>	<input type="radio"/>	<input type="radio"/>	<input type="radio"/>	<input type="radio"/>
A/C relay	<input type="radio"/>	<input type="radio"/>	<input type="radio"/>	<input type="radio"/>	<input type="radio"/>	<input type="radio"/>	<input type="radio"/>	<input type="radio"/>	<input type="radio"/>	<input type="radio"/>	<input type="radio"/>	<input type="radio"/>	<input type="radio"/>	<input type="radio"/>	<input type="radio"/>	<input type="radio"/>
Magnet clutch	<input type="radio"/>	<input type="radio"/>	<input type="radio"/>	<input type="radio"/>	<input type="radio"/>	<input type="radio"/>	<input type="radio"/>	<input type="radio"/>	<input type="radio"/>	<input type="radio"/>	<input type="radio"/>	<input type="radio"/>	<input type="radio"/>	<input type="radio"/>	<input type="radio"/>	<input type="radio"/>
Radiator fan motors (Main and sub)	<input type="radio"/>	<input type="radio"/>	<input type="radio"/>	<input type="radio"/>	<input type="radio"/>	<input type="radio"/>	<input type="radio"/>	<input type="radio"/>	<input type="radio"/>	<input type="radio"/>	<input type="radio"/>	<input type="radio"/>	<input type="radio"/>	<input type="radio"/>	<input type="radio"/>	<input type="radio"/>
Radiator fan relays (Main and sub)	<input type="radio"/>	<input type="radio"/>	<input type="radio"/>	<input type="radio"/>	<input type="radio"/>	<input type="radio"/>	<input type="radio"/>	<input type="radio"/>	<input type="radio"/>	<input type="radio"/>	<input type="radio"/>	<input type="radio"/>	<input type="radio"/>	<input type="radio"/>	<input type="radio"/>	<input type="radio"/>
Sensors (In-vehicle, ambient, water temperature, evaporator, sunload, etc.)	<input type="radio"/>	<input type="radio"/>	<input type="radio"/>	<input type="radio"/>	<input type="radio"/>	<input type="radio"/>	<input type="radio"/>	<input type="radio"/>	<input type="radio"/>	<input type="radio"/>	<input type="radio"/>	<input type="radio"/>	<input type="radio"/>	<input type="radio"/>	<input type="radio"/>	<input type="radio"/>
In-vehicle sensor aspirator duct	<input type="radio"/>	<input type="radio"/>	<input type="radio"/>	<input type="radio"/>	<input type="radio"/>	<input type="radio"/>	<input type="radio"/>	<input type="radio"/>	<input type="radio"/>	<input type="radio"/>	<input type="radio"/>	<input type="radio"/>	<input type="radio"/>	<input type="radio"/>	<input type="radio"/>	<input type="radio"/>

B4M1644B

SYMPTOM RELATED DIAGNOSTIC

HVAC System (Auto A/C) (DIAGNOSTICS)

MEMO: