

A/C CONTROL MODULE I/O SIGNAL

HVAC System (Auto A/C) (DIAGNOSTICS)

4. A/C Control Module I/O Signal S00151a

A: ELECTRICAL SPECIFICATION S00151BA08

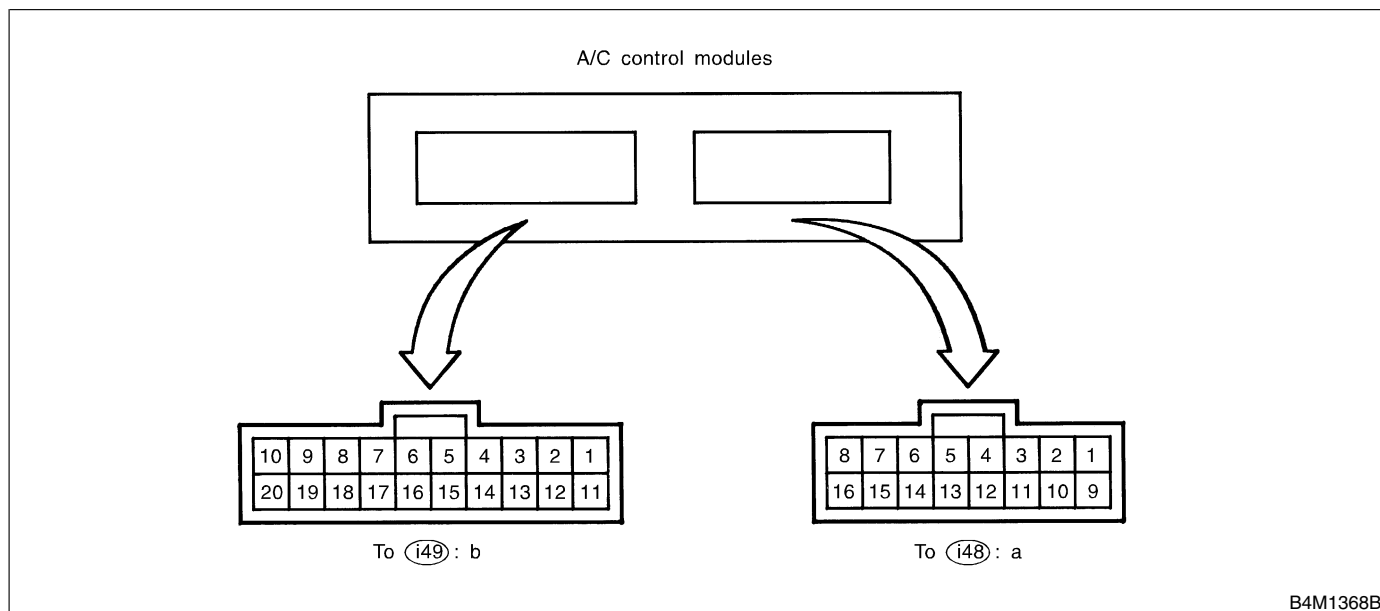

Content	Connector & Terminal No.	Signal (V)
BATT voltage (Memory back-up)	b1—b12	BATT voltage, 13 — 14 (engine running)
IGN power supply	a8—b12	Battery voltage (ignition switch ON), 13 — 14 (engine running)
ACC power supply (OFF: ignition in START or diagnosis system reset)	b2—b12	BATT voltage, 0 (engine cranking), BATT voltage (during engine starts)
A/C control module ground circuit	b12—body	0 (ignition switch ON) — circuit constantly grounded
Sensor ground circuit	b17—body	0 (ignition switch ON) — continuity exists
Ambient sensor	b6—b17	Approx. 3.3 (disconnect connector, and ignition switch ON)
Evaporator sensor	b7—b17	
Thermometer	b15—b12	
Sunload sensor	b16—b17	Approx. 4.2 (disconnect connector, and ignition switch ON)
Air mix door motor	a4—a3	BATT voltage (AUTO mode) positive “+” at terminal “a4” and negative “-” at “a3” [temperature set at 18°C (65°F)]; negative “-” at terminal “a4” and positive “+” at “a13” [temperature set at 32°C (85°F)]
Air mix door motor P.B.R.	a12—b17	Approx. 0.5 [temperature set at 18°C (65°F) in AUTO mode] Approx. 4.5 [temperature set at 32°C (85°F) in AUTO mode]
Mode actuator VENT	a5—b17	BATT voltage (ignition switch ON in MANUAL mode); positive “+” at terminal “a5” and negative “-” at “b17” (VENT); negative “-” at “a5” and positive “+” at “b17” (DEF)
Mode actuator DEF	a6—b17	BATT voltage (ignition switch ON in MANUAL mode) Approx. 4.5 (VENT); approx. 0.5 (DEF)
Intake door FRS voltage	a7—a15	BATT voltage (CIRC switch OFF)
Intake door CIRC voltage	a15—a7	BATT voltage (CIRC switch ON)
Blower fan relay	b14—body	BATT voltage (ignition switch ON)
A/C relay	b3—b12	0 (ignition and A/C switches ON) BATT voltage (A/C switch OFF)
Illumination control signal	b10—b20	BATT voltage (ignition and lighting switches ON)
Rear defogger	a13—b12	0 (IGN ON, R Def SW ON)

A/C CONTROL MODULE I/O SIGNAL

HVAC System (Auto A/C) (DIAGNOSTICS)

B: SCHEMATIC

S001518A21

1. AIR CONDITIONER AUTO A/C

S001518A2103

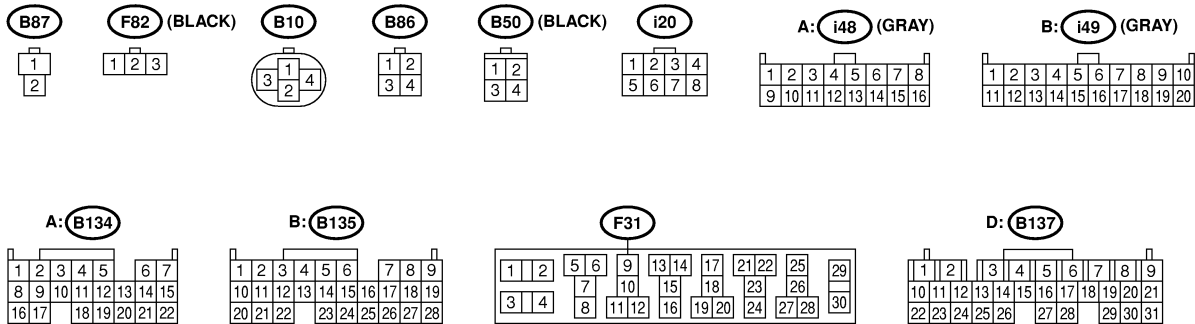
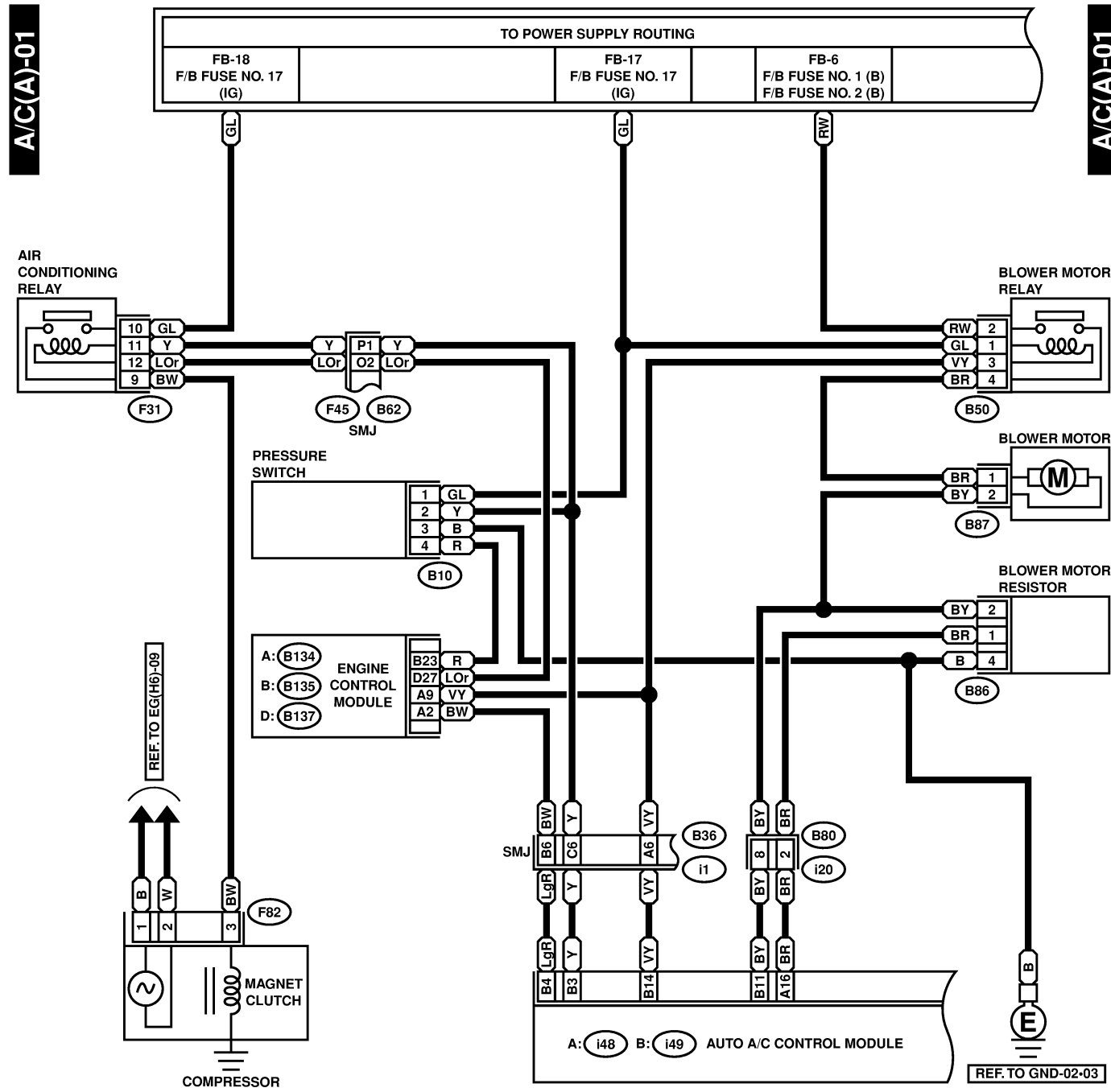

RELAY HOLDER (BLACK)

BU46-20A

A/C CONTROL MODULE I/O SIGNAL

HVAC System (Auto A/C) (DIAGNOSTICS)

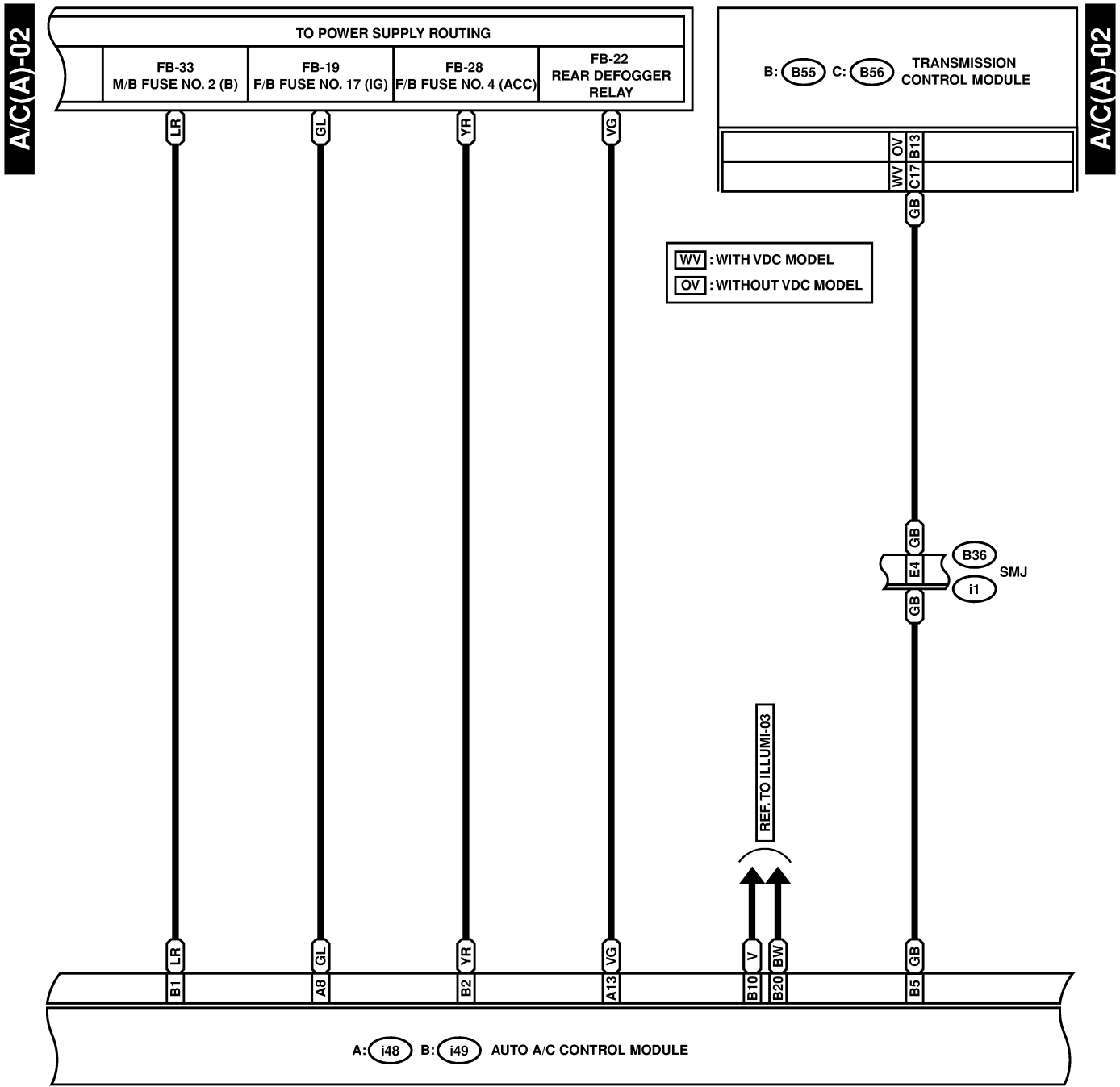

A: i48 (GRAY)

1	2	3	4	5	6	7	8
9	10	11	12	13	14	15	16

B: i49 (GRAY)

1	2	3	4	5	6	7	8	9	10
11	12	13	14	15	16	17	18	19	20

C: B56 (GREEN)

1	2	3	4	5	6	7	8	9
10	11	12	13	14	15	16	17	18
19	20	21				22	23	24

B: B55 (GRAY)

1	2	3	4	5	6	7	8	9
10	11	12	13	14	15	16	17	18
19	20	21				22	23	24

A/C CONTROL MODULE I/O SIGNAL

HVAC System (Auto A/C) (DIAGNOSTICS)

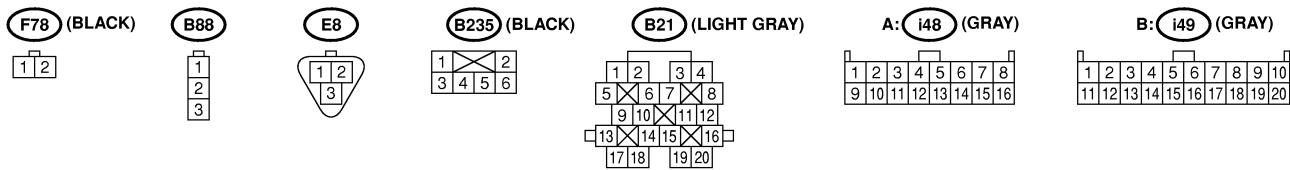
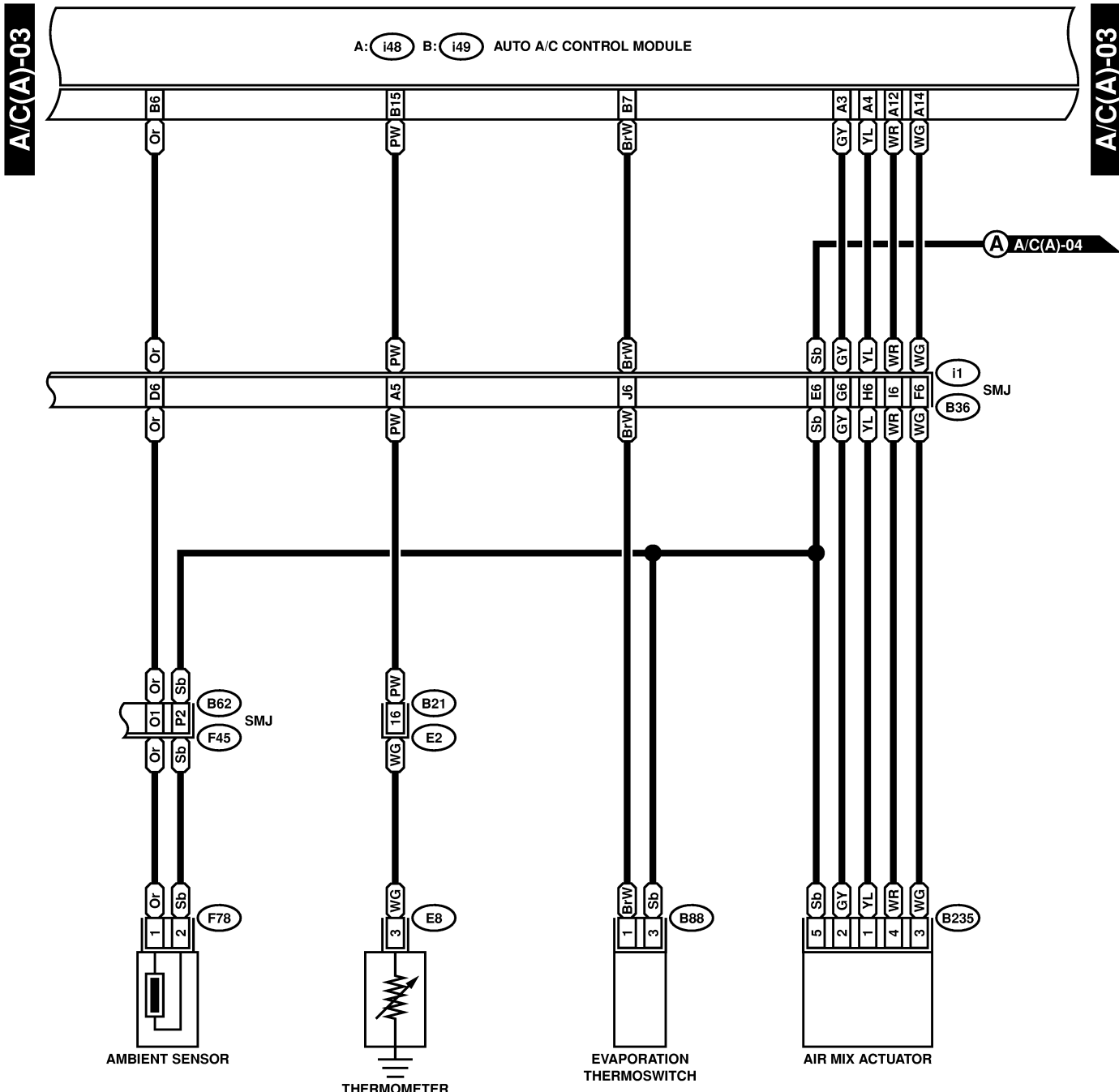

A/C CONTROL MODULE I/O SIGNAL

HVAC System (Auto A/C) (DIAGNOSTICS)

