

DIAGNOSTICS FOR A/C SYSTEM FAILURE

HVAC System (Auto A/C) (DIAGNOSTICS)

6. Diagnostics for A/C System Failure S001625

A: A/C AND/OR SELF-DIAGNOSIS SYSTEMS DO NOT OPERATE S001625F37

TROUBLE SYMPTOM:

- "Set" temperature is not indicated on display, switch LEDs are faulty and switches do not operate.
- Self-diagnosis system does not operate.

WIRING DIAGRAM:

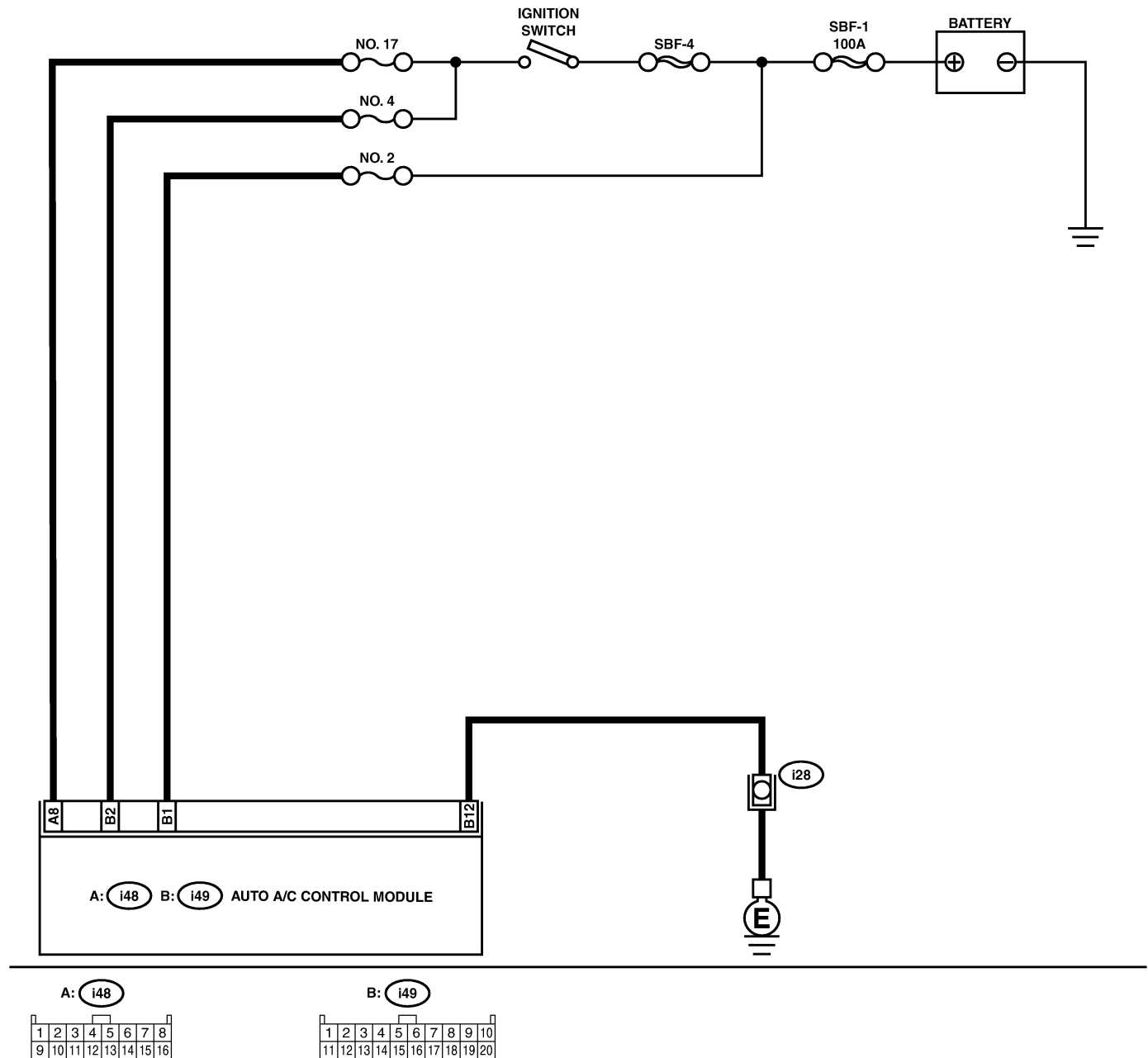

DIAGNOSTICS FOR A/C SYSTEM FAILURE

HVAC System (Auto A/C) (DIAGNOSTICS)

No.	Step	Check	Yes	No
1	CHECK FUSE. 1) Turn ignition switch to OFF. 2) Remove fuse No. 2 from main fuse box. 3) Check condition of fuse.	Is the fuse blown-out?	Replace fuse.	Go to step 2.
2	CHECK FUSE. 1) Turn ignition switch to OFF. 2) Remove fuses No. 4 and No. 17 from joint box. 3) Check condition of fuse.	Is the fuse blown-out?	Replace fuse.	Go to step 3.
3	CHECK A/C CONTROL MODULE POWER CIRCUIT. 1) Pull out A/C control module connector. 2) Measure voltage between A/C control module connector terminal and chassis ground when turning ignition switch to OFF. <i>Connector & terminal</i> <i>(i49) No. 1 (+) — Chassis ground (-):</i>	Is the voltage more than 10 V?	Go to step 4.	Repair short circuit in harness for power supply line.
4	CHECK A/C CONTROL MODULE POWER CIRCUIT. Measure voltage between A/C control module connector terminal and chassis ground when turning ignition switch to ACC. <i>Connector & terminal</i> <i>(i49) No. 2 (+) — Chassis ground (-):</i>	Is the voltage more than 10 V?	Go to step 5.	Repair short circuit in harness for power supply line.
5	CHECK A/C CONTROL MODULE POWER CIRCUIT. Measure voltage between A/C control module connector terminal and chassis ground when turning ignition switch to ON. <i>Connector & terminal</i> <i>(i48) No. 8 (+) — Chassis ground (-):</i>	Is the voltage more than 10 V?	Go to step 6.	Repair short circuit in harness for power supply line.
6	CHECK A/C CONTROL MODULE GROUND CIRCUIT. Measure resistance of harness between A/C control module and chassis ground. <i>Connector & terminal</i> <i>(i49) No. 12 — Chassis ground:</i>	Is the resistance less than 5 Ω ?	Go to step 7.	Repair short circuit in harness for ground line.
7	CHECK POOR CONTACT. Check poor contact in A/C control module.	Is there poor contact in A/C control module?	Repair poor contact in A/C control module.	Contact with SOA (distributor) service.

DIAGNOSTICS FOR A/C SYSTEM FAILURE

HVAC System (Auto A/C) (DIAGNOSTICS)

B: BLOWER MOTOR IS NOT ROTATED S001625F38

TROUBLE SYMPTOM:

- Blower motor is not rotated.
- Blower motor is not rotated in "HI".

WIRING DIAGRAM:

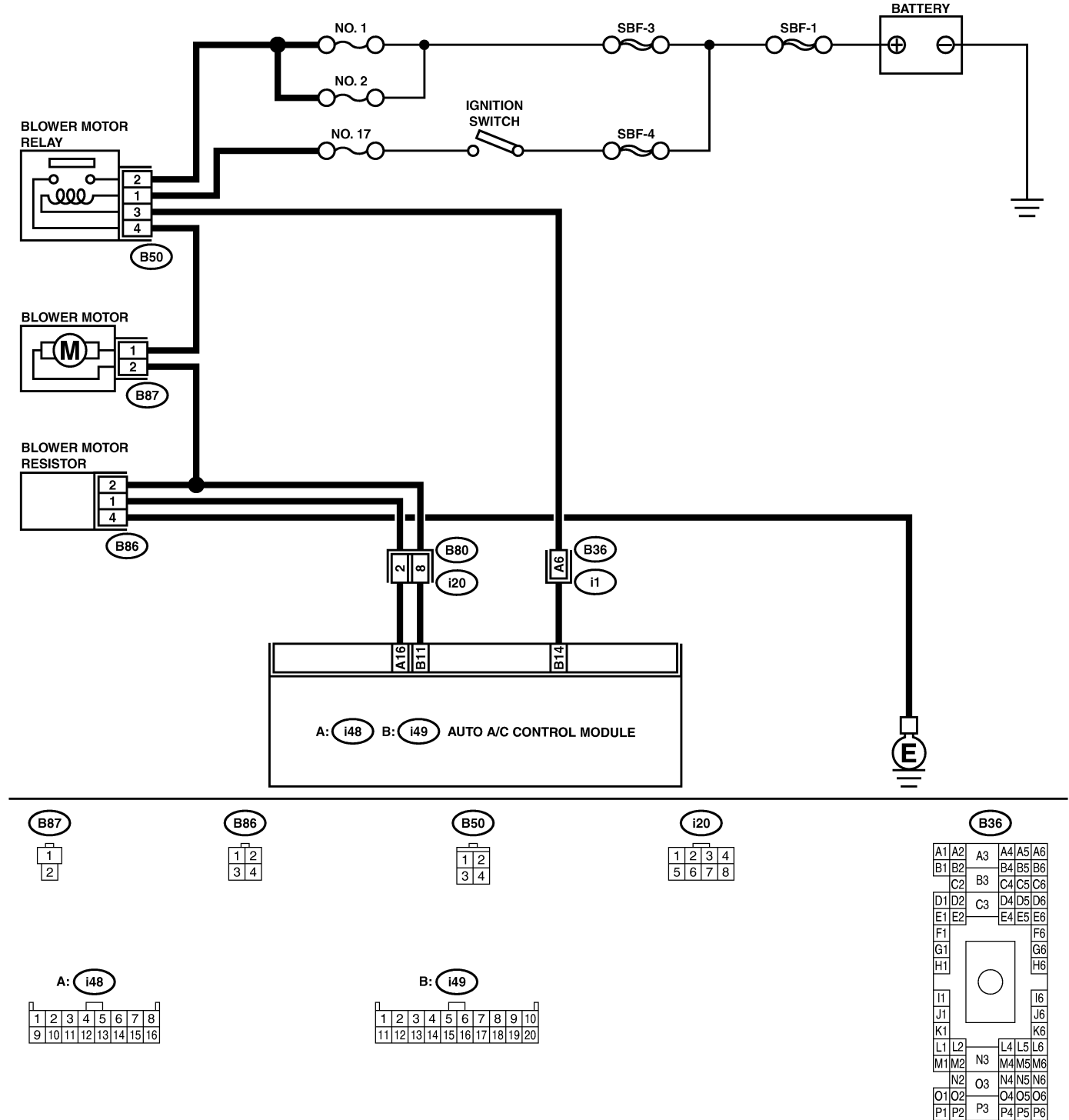

B4M2372

DIAGNOSTICS FOR A/C SYSTEM FAILURE

HVAC System (Auto A/C) (DIAGNOSTICS)

No.	Step	Check	Yes	No
1	CHECK FUSE. 1) Remove No. 2 and No. 17 fuses in joint box. 2) Check condition of fuses.	Are any of the fuses blown-out?	Replace fuse.	Go to step 2.
2	CHECK POWER SUPPLY TO BLOWER FAN MOTOR. 1) Turn ignition switch to ON. 2) Turn blower switch to ON. 3) Measure voltage between blower fan motor and chassis ground. Connector & terminal (B87) No. 1 (+) — Chassis ground (-):	Is the voltage more than 10 V?	Go to step 3.	Repair open circuit in harness for blower fan motor power supply line.
3	CHECK BLOWER FAN MOTOR RELAY. 1) Turn ignition switch to OFF. 2) Remove blower fan motor relay. 3) Connect battery to No. 1 and No. 3 terminals of blower fan motor connector. 4) Measure resistance between No. 2 and No. 4 terminals. Terminals: No. 2 — No. 4	Is the resistance less than 1 Ω ?	Go to step 4.	Replace blower fan motor relay.
4	CHECK BLOWER FAN MOTOR. 1) Disconnect connector from blower fan motor. 2) Connect battery to connector terminals of blower fan motor. 3) Make sure that blower fan motor is operated.	Does the blower fan motor operate?	Go to step 5.	Replace blower fan motor.
5	CHECK POOR CONTACT. Check poor contact in A/C control module.	Is there poor contact in A/C control module?	Repair poor contact in A/C control module.	Contact with SOA (distributor) service.

DIAGNOSTICS FOR A/C SYSTEM FAILURE

HVAC System (Auto A/C) (DIAGNOSTICS)

C: FRESH/RECIRC IS NOT CHANGED S001625F39

TROUBLE SYMPTOM:

FRESH/RECIRC mode door is not changed.

WIRING DIAGRAM:

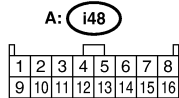
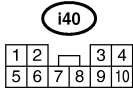
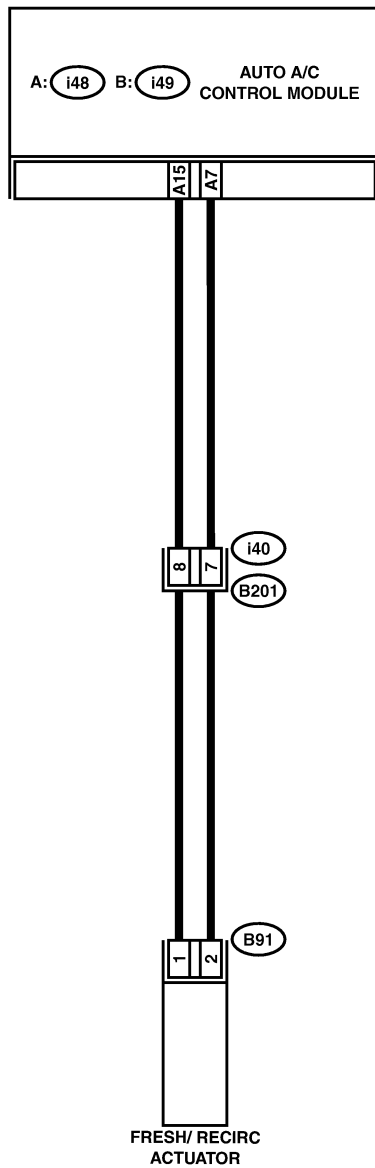

B4M2373

DIAGNOSTICS FOR A/C SYSTEM FAILURE

HVAC System (Auto A/C) (DIAGNOSTICS)

No.	Step	Check	Yes	No
1	CHECK SWITCH OPERATION. Make sure that the mode selection on display is changed when pushing the "MODE" switch.	Does the mode selection change?	Go to step 7.	Go to step 2.
2	CHECK FUSE. 1) Remove No. 17 fuse in joint box. 2) Check condition of fuse.	Is the fuse blown-out?	Replace fuse.	Go to step 3.
3	CHECK SIGNAL VOLTAGE. 1) Change display to RECIRC by pushing MODE switch. 2) Measure voltage between A/C control module and chassis ground. Connector & terminal <i>(i48) No. 15 (+) — Chassis ground (-):</i>	Is the voltage less than 1 V?	Go to step 4.	Repair short circuit in harness for power supply line.
4	CHECK SIGNAL VOLTAGE. 1) Change display to FRESH with pushing MODE switch. 2) Measure voltage between A/C control module and chassis ground. Connector & terminal <i>(i48) No. 7 (+) — Chassis ground (-):</i>	Is the voltage less than 1 V?	Go to step 5.	Repair short circuit in harness for power supply line.
5	CHECK HARNESS CONNECTOR BETWEEN A/C CONTROL MODULE AND FRESH/RECIRC ACTUATOR. 1) Turn ignition switch to OFF. 2) Disconnect connector from A/C control module and mode door motor. 3) Measure resistance of harness between A/C control module and FRESH/RECIRC actuator. Connector & terminal: <i>(i48) No. 15 — (B91) No. 1</i>	Is the resistance less than 1 Ω ?	Go to step 6.	Repair open circuit in harness between A/C control module and FRESH/RECIRC actuator.
6	CHECK HARNESS CONNECTOR BETWEEN A/C CONTROL MODULE AND FRESH/RECIRC ACTUATOR. Measure resistance of harness between A/C control module and FRESH/RECIRC actuator. Connector & terminal: <i>(i48) No. 7 — (B91) No. 2</i>	Is the resistance less than 1 Ω ?	Go to step 7.	Repair open circuit in harness between A/C control module and FRESH/RECIRC actuator.
7	CHECK POOR CONTACT. Check poor contact in A/C control module.	Is there poor contact in A/C control module?	Repair poor contact in A/C control module.	Contact with SOA (distributor) service.

DIAGNOSTICS FOR A/C SYSTEM FAILURE

HVAC System (Auto A/C) (DIAGNOSTICS)

D: COMPARTMENT TEMPERATURE IS NOT CHANGED OR A/C SYSTEM DOES NOT RESPOND QUICKLY

S001625F40

WIRING DIAGRAM:

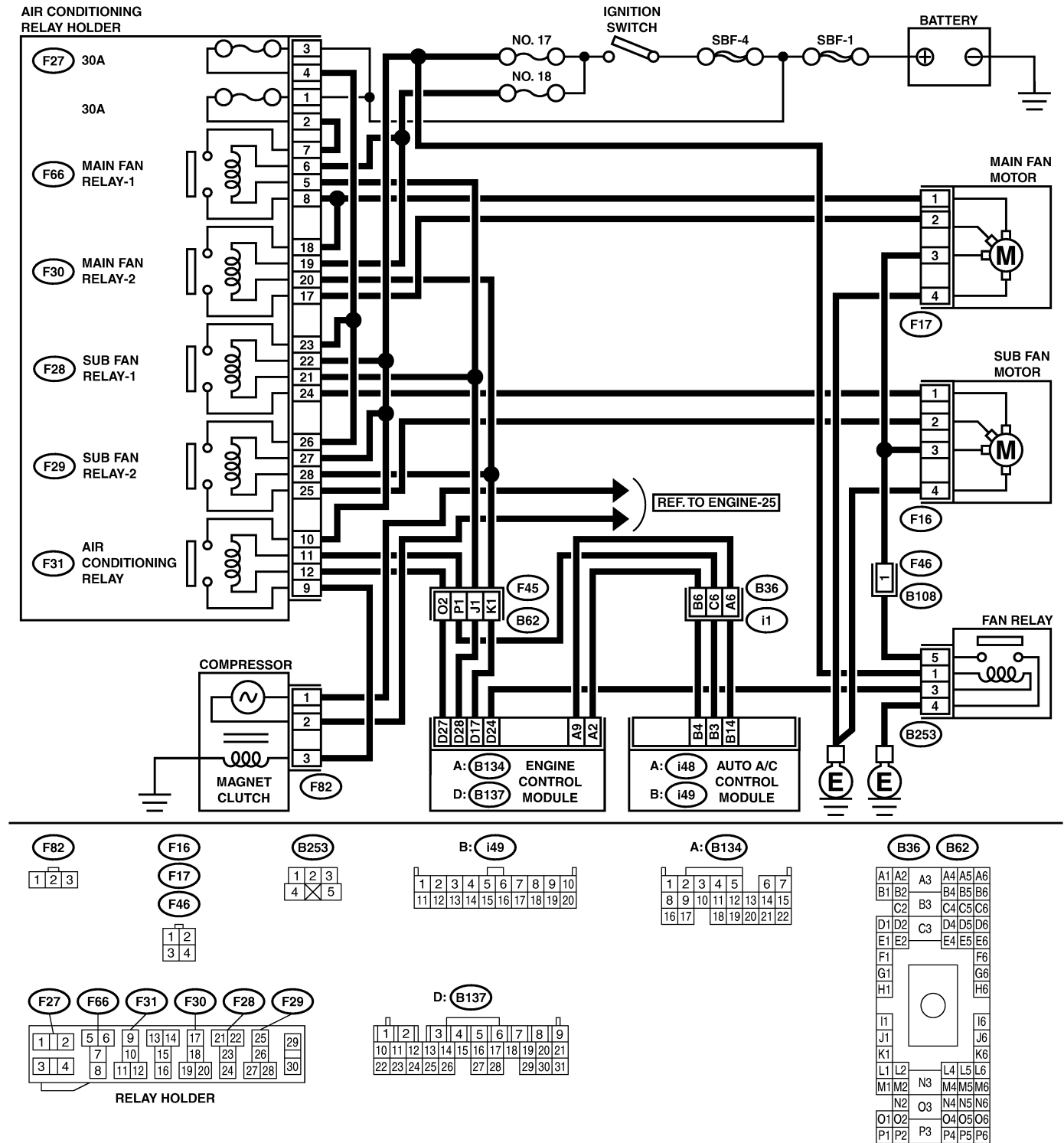

B4M2374

DIAGNOSTICS FOR A/C SYSTEM FAILURE

HVAC System (Auto A/C) (DIAGNOSTICS)

No.	Step	Check	Yes	No
1	CHECK FUSE. 1) Turn ignition switch to OFF. 2) Remove No. 2 fuse in main fuse box. 3) Check condition of fuse.	Is the fuse blown-out?	Replace fuse.	Go to step 2.
2	CHECK POWER SUPPLY TO MAGNET CLUTCH OF A/C COMPRESSOR. 1) Start the engine, and turn A/C switch to ON. 2) Set the compartment temperature at 18°C (65°F) (MAX COOL). 3) Measure voltage between magnet clutch connector and chassis ground. Connector & terminal (F82) No. 3 (+) — Chassis ground (-):	Is the voltage more than 10 V?	Go to step 3.	Repair open circuit in harness for power supply line of the A/C compressor.
3	CHECK SIGNAL VOLTAGE TO A/C RELAY. 1) Turn ignition switch to ON. 2) Turn A/C switch to ON. 3) Measure signal voltage to A/C relay and chassis ground. Connector & terminal (F31) No. 9 (+) — Chassis ground (-):	Is the voltage more than 10 V?	Go to step 4.	Repair open circuit in harness for power supply line.
4	CHECK A/C RELAY. 1) Remove A/C relay in main fuse box. 2) Check A/C relay. <Ref. to AC-40, INSPECTION, Relay and Fuse.>	Is the operation of each relay OK?	Go to step 5.	Replace A/C relay.
5	CHECK OPERATION OF MAIN FAN MOTOR. 1) Start the engine. 2) Turn A/C switch to ON. 3) Check operation of main fan motor.	Does the radiator main fan operate?	Go to step 10.	Go to step 6.
6	CHECK POWER SUPPLY TO MAIN FAN MOTOR. CAUTION: Be careful not to overheat engine during repair. 1) Turn ignition switch to OFF. 2) Disconnect connector from main fan motor. 3) Start the engine, and warm it up until engine coolant temperature increases over 95°C (203°F). 4) Stop the engine and turn ignition switch to ON. 5) Measure voltage between main fan motor connector and chassis ground. Connector & terminal (F17) No. 1, 2 (+) — Chassis ground (-):	Is the voltage more than 10 V?	Go to step 7.	Repair open circuit in harness for power supply circuit.
7	CHECK GROUND CIRCUIT OF MAIN FAN MOTOR. 1) Turn ignition switch to OFF. 2) Measure resistance between main fan motor connector and chassis ground. Connector & terminal (F17) No. 4 — Chassis ground:	Is the resistance less than 1 Ω?	Go to step 8.	Repair open circuit in harness between main fan motor connector and chassis ground.
8	CHECK POOR CONTACT. Check poor contact in main fan motor connector.	Is there poor contact in main fan motor connector?	Repair poor contact in main fan motor connector.	Go to step 9.

DIAGNOSTICS FOR A/C SYSTEM FAILURE

HVAC System (Auto A/C) (DIAGNOSTICS)

No.	Step	Check	Yes	No
9	CHECK MAIN FAN MOTOR. Connect battery positive (+) terminal to terminal No. 1, 2, and negative (-) terminal to terminal No. 4 of main fan motor connector.	Does the main fan rotate?	Repair poor contact in main fan motor connector.	Replace main fan motor with a new one.
10	CHECK OPERATION OF SUB FAN MOTOR. Check operation of sub fan motor.	Does the radiator sub fan operate?	Go to step 15.	Go to step 11.
11	CHECK POWER SUPPLY TO SUB FAN MOTOR. CAUTION: Be careful not to overheat engine during repair. 1) Turn ignition switch to OFF. 2) Disconnect connector from sub fan motor. 3) Start the engine, and warm it up until engine coolant temperature increases over 100°C (212°F). 4) Stop the engine and turn ignition switch to ON. 5) Measure voltage between sub fan motor connector and chassis ground. Connector & terminal (F16) No. 1, 2 (+) — Chassis ground (-):	Is the voltage more than 10 V?	Go to step 12.	Repair open circuit in harness for power supply circuit.
12	CHECK GROUND CIRCUIT OF SUB FAN MOTOR. 1) Turn ignition switch to OFF. 2) Measure resistance between sub fan motor connector and chassis ground. Connector & terminal (F16) No. 4 — Chassis ground:	Is the resistance less than 1 Ω?	Go to step 13.	Repair open circuit in harness between sub fan motor connector and chassis ground.
13	CHECK POOR CONTACT. Check poor contact in sub fan motor connector.	Is there poor contact in sub fan motor connector?	Repair poor contact in sub fan motor connector.	Go to step 14.
14	CHECK SUB FAN MOTOR. Connect battery positive (+) terminal to terminal No. 1, 2, and negative (-) terminal to terminal No. 4 of sub fan motor connector.	Does the sub fan rotate?	Repair poor contact in sub fan motor connector.	Replace sub fan motor with a new one.
15	CHECK EACH SENSOR AND POTENTIOMETER. Check the sensors and potentiometer for proper operation using the self-diagnostic function. <Ref. to AC-12, Diagnostics Chart for Diagnosis System.>	Is the operation of each sensor and potentiometer normal?	Go to step 16.	Replace sensor and/or potentiometer.
16	CHECK CONNECTION OF ASPIRATOR DUCT. Make sure that the connection of aspirator duct is correct.	Is the connection of aspirator duct correct?	Repair aspirator duct connection.	Go to step 17.
17	CHECK EACH ACTUATOR. Check the actuators for proper operation using the self-diagnostic function. <Ref. to AC-12, Diagnostics Chart for Diagnosis System.>	Is the operation of each actuator normal?	Go to step 18.	Replace actuator.
18	CHECK POOR CONTACT. Check poor contact in A/C control module.	Is there poor contact in A/C control module?	Repair poor contact in A/C control module.	Contact with SOA (distributor) service.