

GENERAL DESCRIPTION

HVAC System (Heater, Ventilator and A/C)

1. General Description S701001

A: SPECIFICATIONS S701001E49

1. HEATER SYSTEM S701001E4901

Item		Specifications	Condition
Heating capacity		5.0 kW (4,300 kcal/h, 17,062 BTU/h) or more	<ul style="list-style-type: none"> ● Mode selector switch: HEAT ● Temperature control switch: FULL HOT ● Temperature difference between hot water and inlet air: 65°C (149°F) ● Hot water flow rate: 360 ℓ (95.1 US gal, 79.2 Imp gal)/h
Air flow rate		300 m ³ (10,593 cu ft)/h	Heat mode (FRESH), FULL HOT at 12.5 V
Max air flow rate		500 m ³ (17,655 cu ft)/h	<ul style="list-style-type: none"> ● Temperature control switch: FULL COLD ● Blower fan speed: 4th position ● Mode selector lever: RECIRC
Heater core size (height × length × width)		193.5 × 152 × 35.0 mm (7.62 × 5.98 × 1.378 in)	—
Blower motor	Type	Magnet motor 220 W or less	at 12 V
	Fan type and size (diameter × width)	Sirocco fan type 150 × 75 mm (5.91 × 2.95 in)	—

GENERAL DESCRIPTION

HVAC System (Heater, Ventilator and A/C)

2. A/C SYSTEM (4 CYLINDER) S701001E4903

Item		Specifications	
Type of air conditioner		Reheat air-mix type	
Cooling capacity		5.2 kW (4,471 kcal/h, 17,741 BTU/h)	
Refrigerant		HFC-134a (CH ₂ FCF ₃) [0.65±0.05 kg (1.43±0.11 lb)]	
Compressor	Type	5-vane rotary, fix volume (DKV-14G)	
	Discharge	140 cm ³ (8.54 cu in)/rev	
	Max. permissible speed	7,000 rpm	
Magnet clutch	Type	Dry, single-disc type	
	Power consumption	45 W	
	Type of belt	V-Ribbed 4 PK	
	Pulley dia. (effective dia.)	125 mm (4.92 in)	
	Pulley ratio	1.064	
Condenser	Type	Corrugated fin (Multi-flow)	
	Core face area	0.21 m ² (2.26 sq ft)	
	Core thickness	24 mm (0.94 in)	
	Radiation area	6.52 m ² (70 sq ft)	
Receiver drier	Effective inner capacity	250 cm ³ (15.26 cu in)	
Expansion valve	Type	Internal equalizing	
Evaporator	Type	Single tank	
	Dimensions (W × H × T)	235 × 224 × 60 mm (9.25 × 8.82 × 2.36 in)	
Blower fan	Fan type	Sirocco fan	
	Outer diameter × width	150 × 75 mm (5.91 × 2.95 in)	
	Power consumption	220 W at 12 V	
Condenser fan (Sub fan)	Motor type	Magnet	
	Power consumption	75 W at 12 V	
	Fan outer diameter	300 mm (11.81 in)	
Radiator fan (Main fan)	Motor type	Magnet	
	Power consumption	75 W at 12 V	
	Fan outer diameter	300 mm (11.81 in)	
Idling speed (A/C ON)	MPFI model	850±100 rpm	
Dual switch (Pressure switch)	Low-pressure switch operating pressure	ON → OFF	177±25 kPa (1.80±0.25 kg/cm ² , 25.6±3.6 psi)
		OFF → ON	216 ^{+39/-25} kPa (2.2 ^{+0.4/-0.25} kg/cm ² , 31 ^{+5.7/-3.6} psi)
	High-pressure switch operating pressure	ON → OFF	2,942±196 kPa (30±2 kg/cm ² , 427±28 psi)
		DIFF	588±196 kPa (6±2 kg/cm ² , 85±28 psi)
Thermo control amplifier working temperature (Evaporator outlet air)	<p style="text-align: center;"> OFF ————— 1.5±0.5°C (35±0.9°F) ————— ON Diff. 3.0±0.3°C (37±0.5°F) </p>		

B4M2237A

GENERAL DESCRIPTION

HVAC System (Heater, Ventilator and A/C)

3. A/C SYSTEM (6 CYLINDER) S701001E4904

Item		Specifications	
Type of air conditioner		Reheat air-mix type	
Cooling capacity		5.2 kW (4,471 kcal/h, 17,741 BTU/h)	
Refrigerant		HFC-134a (CH ₂ FCF ₃) [0.65±0.05 kg (1.43±0.11 lb)]	
Compressor	Type	5-vane rotary, fix volume (DKV-14G)	
	Discharge	140 cm ³ (8.54 cu in)/rev	
	Max. permissible speed	7,000 rpm	
Magnet clutch	Type	Dry, single-disc type	
	Power consumption	38 W	
	Type of belt	V-Ribbed 6 PK	
	Pulley dia. (effective dia.)	125 mm (4.92 in)	
	Pulley ratio	1.064	
Condenser	Type	Corrugated fin (Multi-flow)	
	Core face area	0.22 m ² (2.37 sq ft)	
	Core thickness	24 mm (0.94 in)	
	Radiation area	6.52 m ² (70 sq ft)	
Receiver drier	Effective inner capacity	250 cm ³ (15.26 cu in)	
Expansion valve	Type	Internal equalizing	
Evaporator	Type	Single tank	
	Dimensions (W × H × T)	235 × 224 × 60 mm (9.25 × 8.82 × 2.36 in)	
Blower fan	Fan type	Sirocco fan	
	Outer diameter × width	150 × 75 mm (5.91 × 2.95 in)	
	Power consumption	220 W at 12 V	
Condenser fan (Sub fan)	Motor type	Magnet	
	Power consumption	120 W at 12 V	
	Fan outer diameter	320 mm (12.60 in)	
Radiator fan (Main fan)	Motor type	Magnet	
	Power consumption	120 W at 12 V	
	Fan outer diameter	320 mm (12.60 in)	
Idling speed (A/C ON)	MPFI model	850±100 rpm	
Dual switch (Pressure switch)	Low-pressure switch operating pressure	ON → OFF	177±25 kPa (1.80±0.25 kg/cm ² , 25.6±3.6 psi)
		OFF → ON	216 ⁺³⁹ / ₋₂₅ kPa (2.2 ^{+0.4} / _{-0.25} kg/cm ² , 31 ^{+5.7} / _{-3.6} psi)
	High-pressure switch operating pressure	ON → OFF	2,942±196 kPa (30±2 kg/cm ² , 427±28 psi)
		DIFF	588±196 kPa (6±2 kg/cm ² , 85±28 psi)
Thermo control amplifier working temperature (Evaporator outlet air)	<p style="text-align: center;"> OFF ————— ON 1.5±0.5°C (35±0.9°F) Diff. 3.0±0.3°C (37±0.5°F) </p>		

B4M2237A

GENERAL DESCRIPTION

HVAC System (Heater, Ventilator and A/C)

B: COMPONENT S701001A05

1. HEATER UNIT S701001A0501

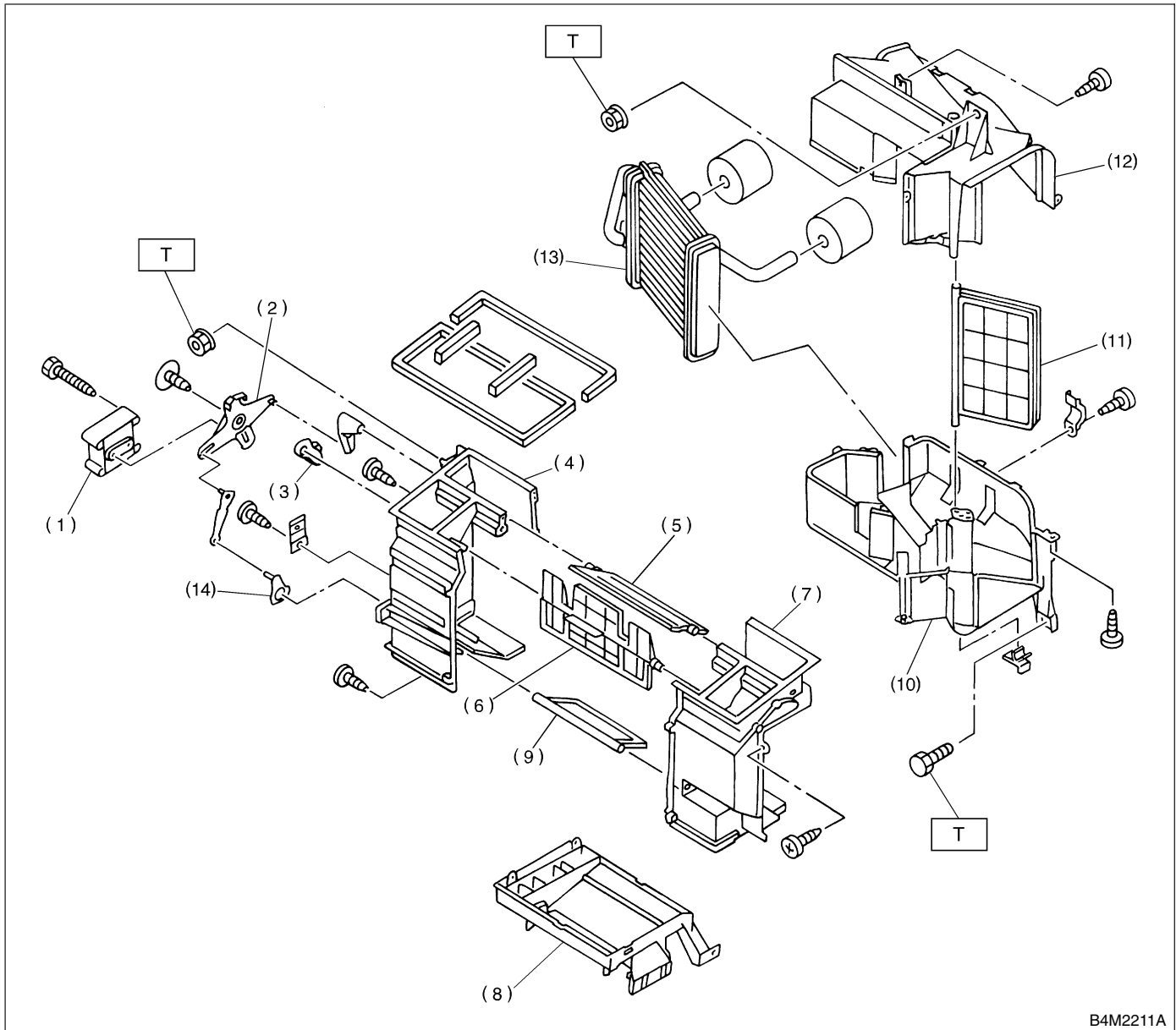

- (1) Vent door actuator
- (2) Side link
- (3) Vent door lever
- (4) Case A
- (5) DEF door
- (6) Vent door

- (7) Case B
- (8) Foot duct
- (9) Foot door
- (10) Case D
- (11) Mix door
- (12) Case C

- (13) Heater core
- (14) Foot door lever

Tightening torque: N-m (kgf-m, ft-lb)
T: 7.35 (0.750, 5.421)

GENERAL DESCRIPTION

HVAC System (Heater, Ventilator and A/C)

2. INTAKE UNIT S701001A0502

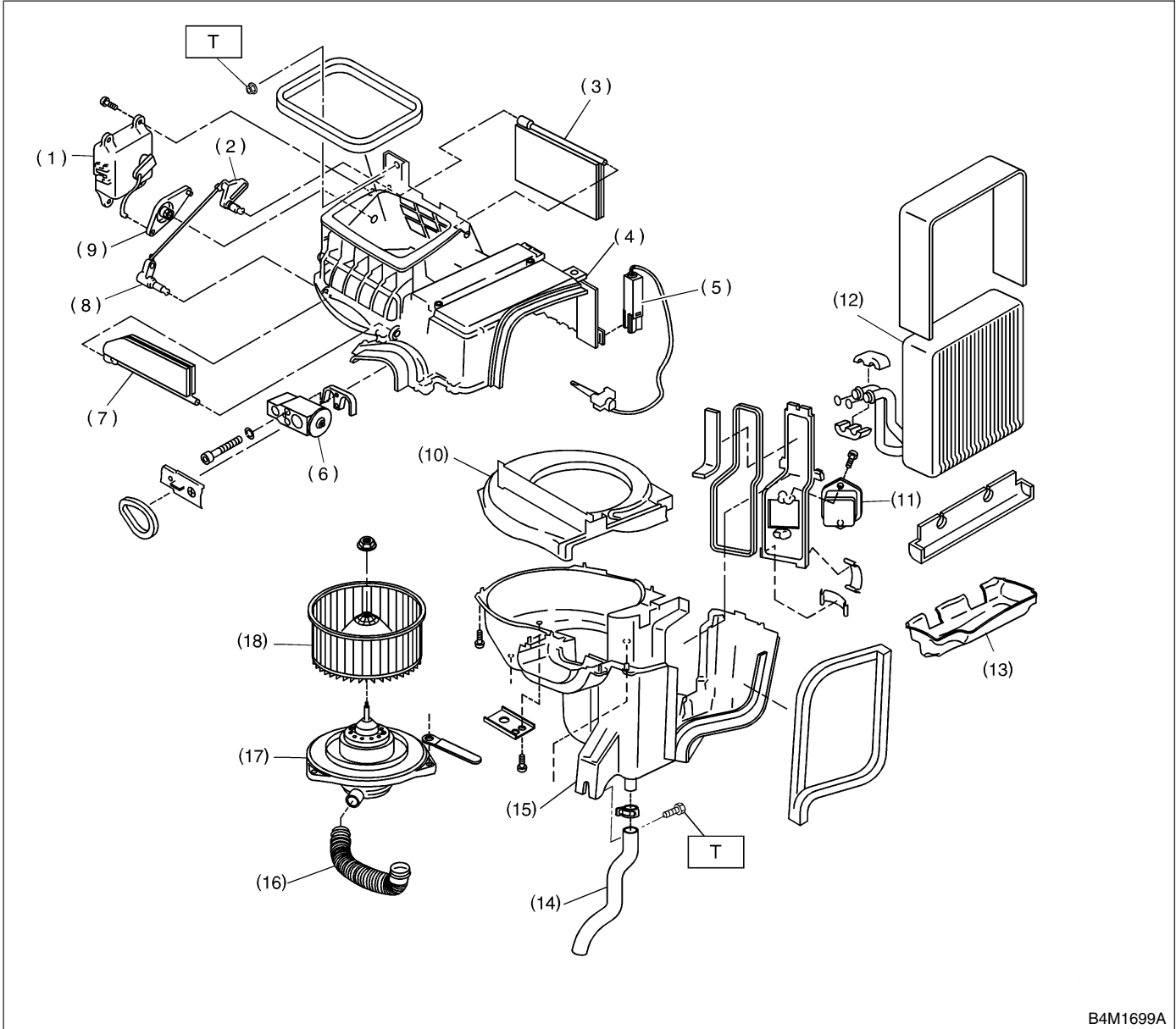

- | | | |
|--|---------------------------------------|-----------------------------|
| (1) Intake door actuator | (8) Lever (B) | (15) Intake unit case lower |
| (2) Lever (A) | (9) Lever (C) | (16) Aspirator pipe |
| (3) Door (A) | (10) Blower plate | (17) Blower motor |
| (4) Intake unit case upper | (11) Resistor | (18) Fan |
| (5) Thermistor (With A/C model) | (12) Evaporator (With A/C model) | |
| (6) Block expansion valve (With A/C model) | (13) Evaporator case (With A/C model) | |
| (7) Door (B) | (14) Drain hose | |

Tightening torque: N·m (kgf·m, ft·lb)
T: 7.4 (0.75, 5.4)

GENERAL DESCRIPTION

HVAC System (Heater, Ventilator and A/C)

3. CONTROL UNIT (MANUAL A/C) S701001A0507

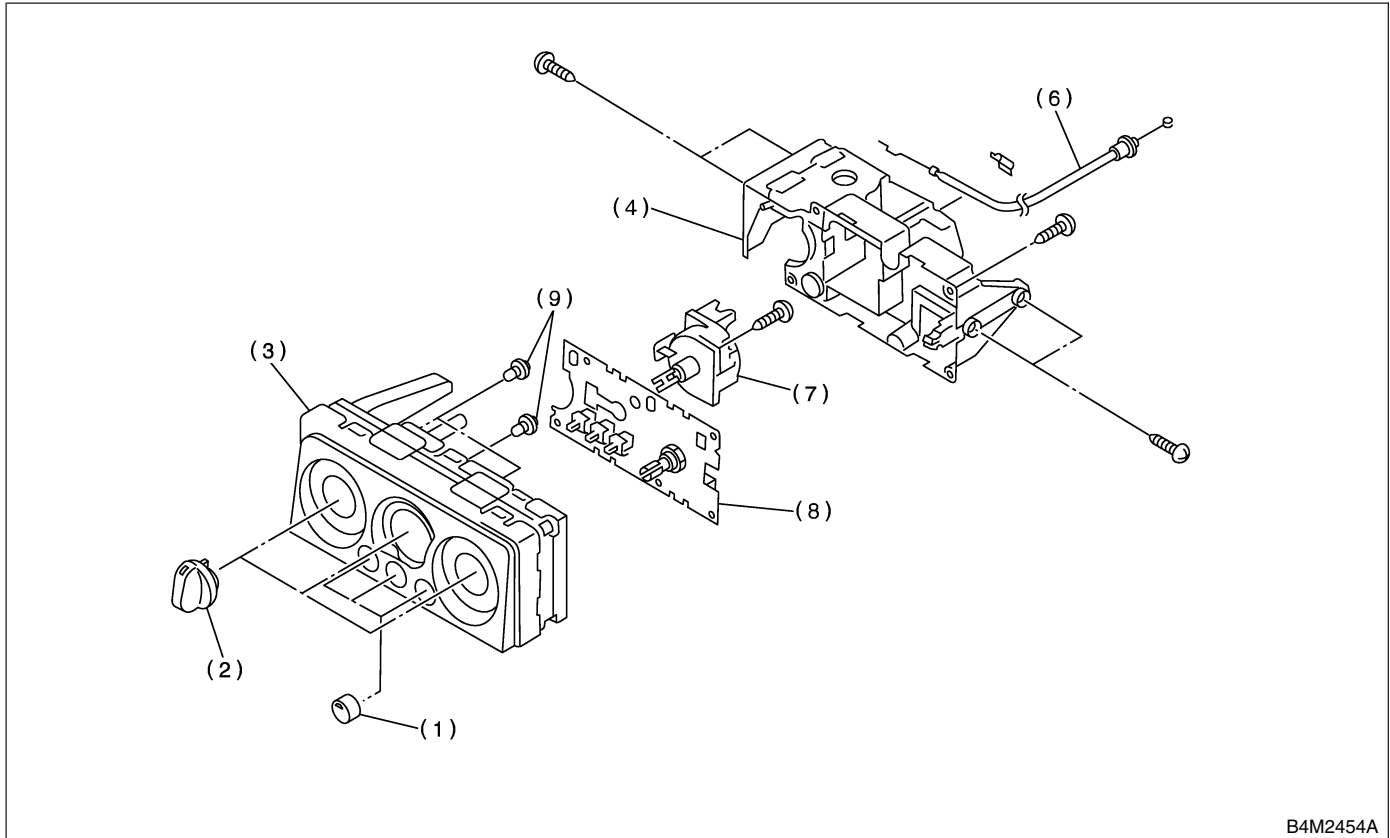

B4M2454A

- | | | |
|------------------------|-------------------------------|---------------------|
| (1) Switch | (4) Base unit | (7) Fan switch ASSY |
| (2) Control dial knob | (5) Cover | (8) Circuit ASSY |
| (3) Control panel ASSY | (6) Temperature control cable | (9) Bulb |

GENERAL DESCRIPTION

HVAC System (Heater, Ventilator and A/C)

4. CONTROL UNIT (AUTO A/C) S701001A0508

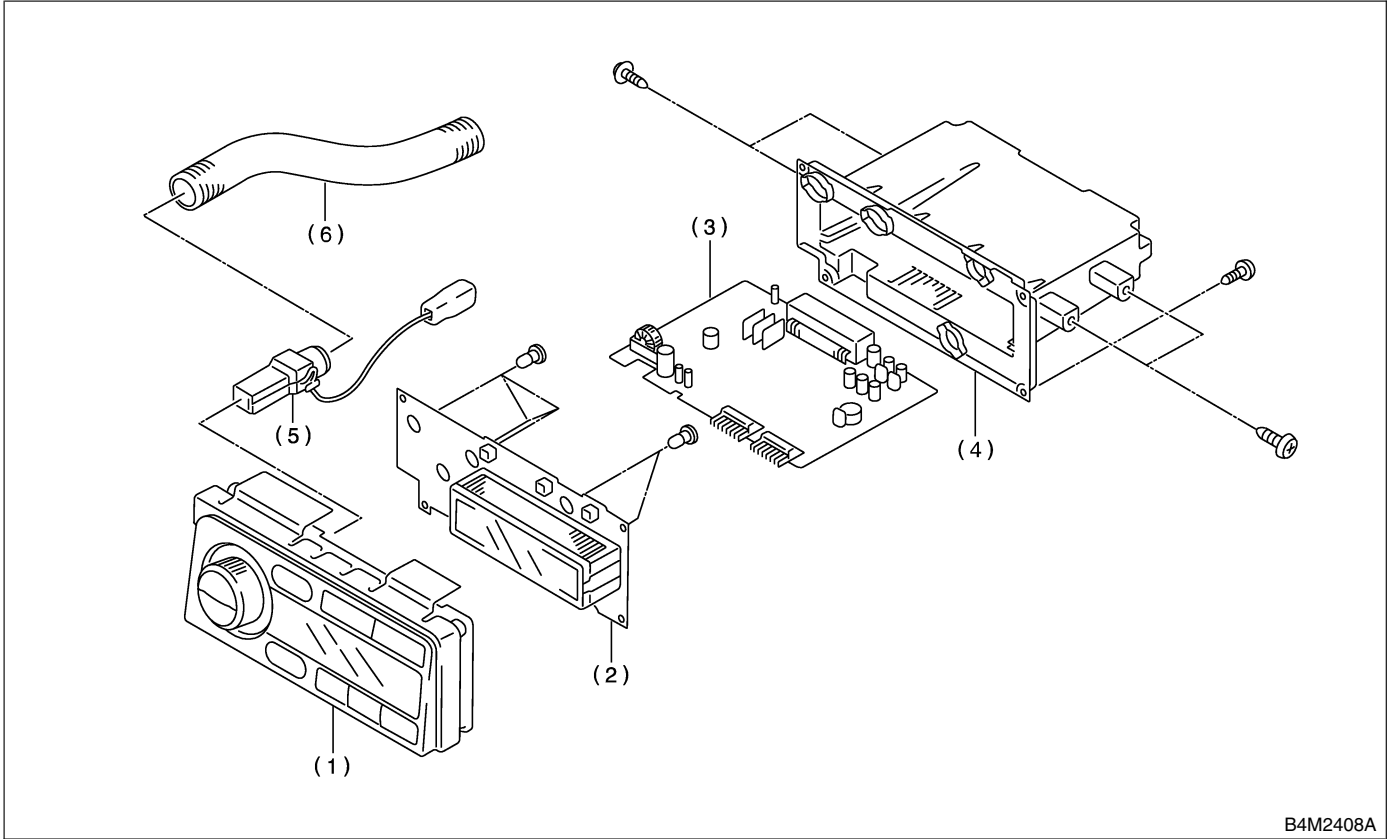

B4M2408A

(1) Control panel
(2) Circuit ASSY

(3) Electronic control unit
(4) Control case

(5) In-car sensor
(6) Aspirator hose

GENERAL DESCRIPTION

HVAC System (Heater, Ventilator and A/C)

5. AIR CONDITIONING UNIT S701001A0504

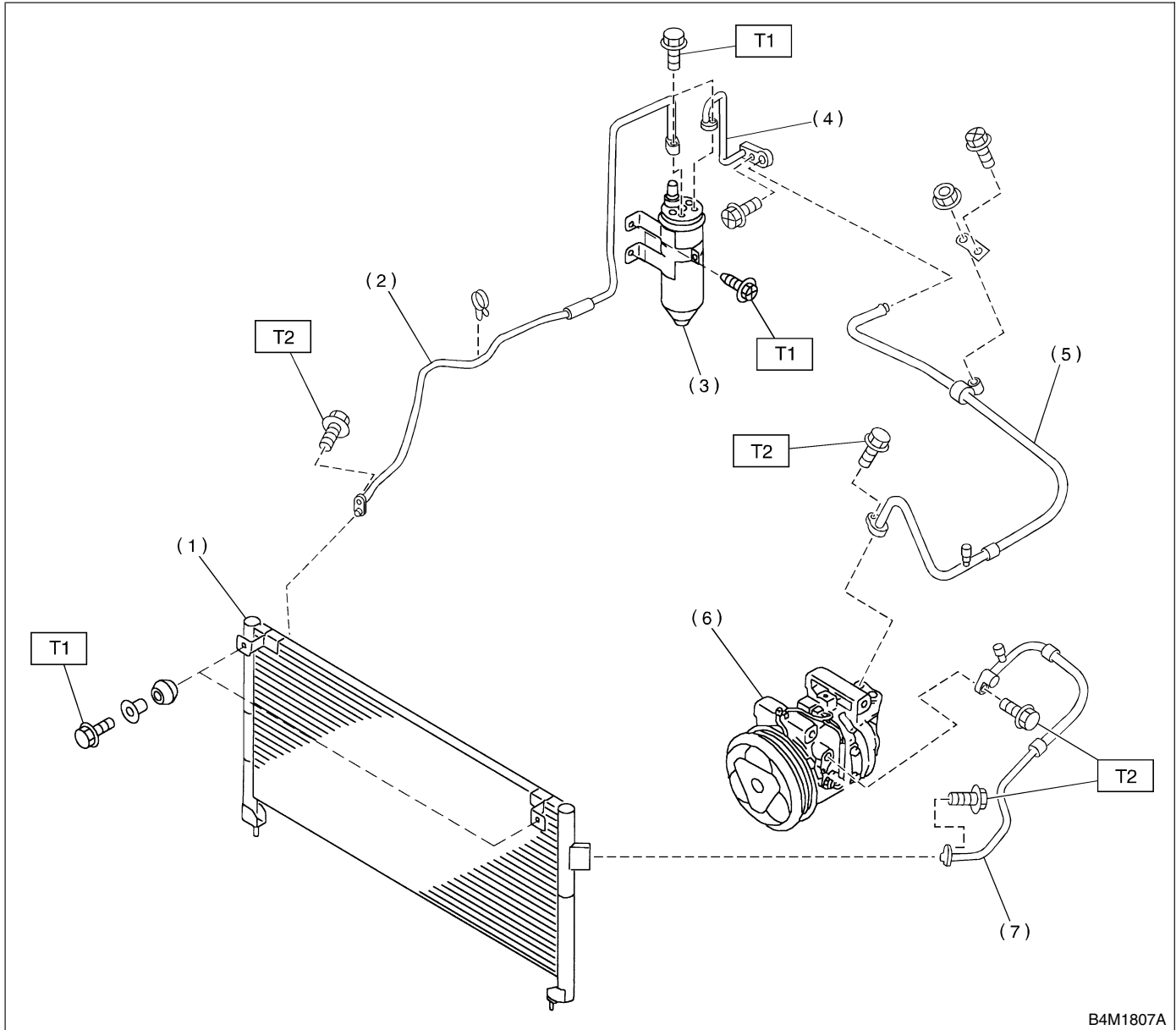

- | | |
|---------------------------------------|--------------------------|
| (1) Condenser | (5) Hose (Low-pressure) |
| (2) Pipe (Condenser — Receiver drier) | (6) Compressor |
| (3) Receiver drier | (7) Hose (High-pressure) |
| (4) Pipe (Receiver drier — C/unit) | |

Tightening torque: N·m (kgf·m, ft·lb)

T1: 7.4 (0.75, 5.4)

T2: 15 (1.5, 10.8)

GENERAL DESCRIPTION

HVAC System (Heater, Ventilator and A/C)

6. INTAKE UNIT WITH EVAPORATOR

S701001A0505

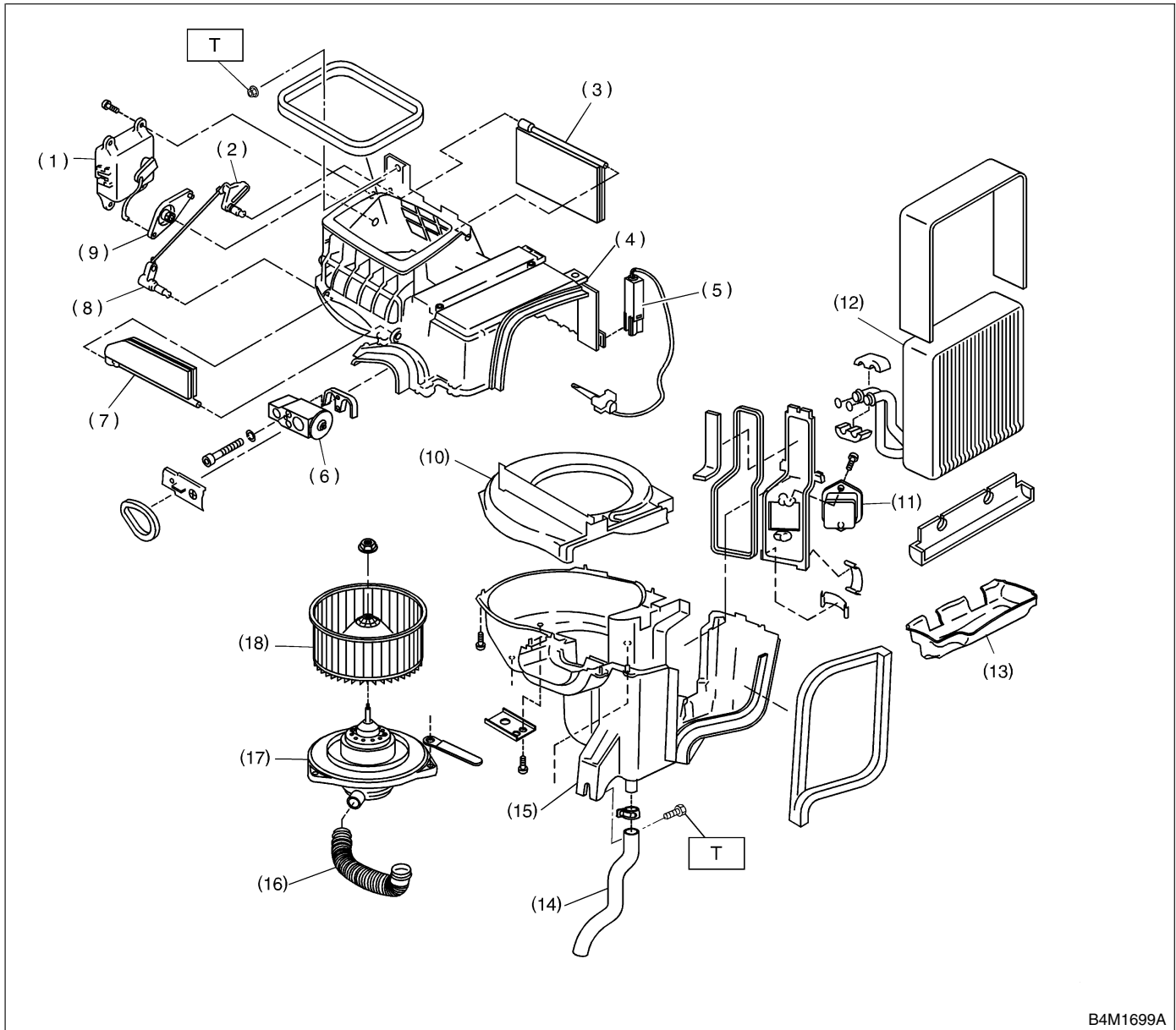

B4M1699A

- | | | |
|--|---------------------------------------|-----------------------------|
| (1) Intake door actuator | (8) Lever (B) | (15) Intake unit case lower |
| (2) Lever (A) | (9) Lever (C) | (16) Aspirator pipe |
| (3) Door (A) | (10) Blower plate | (17) Blower motor |
| (4) Intake unit case upper | (11) Resistor | (18) Fan |
| (5) Thermistor (With A/C model) | (12) Evaporator (With A/C model) | |
| (6) Block expansion valve (With A/C model) | (13) Evaporator case (With A/C model) | |
| (7) Door (B) | (14) Drain hose | |

Tightening torque: N·m (kgf·m, ft·lb)
T: 7.35 (0.750, 5.421)

GENERAL DESCRIPTION

HVAC System (Heater, Ventilator and A/C)

7. COMPRESSOR S701001A0506

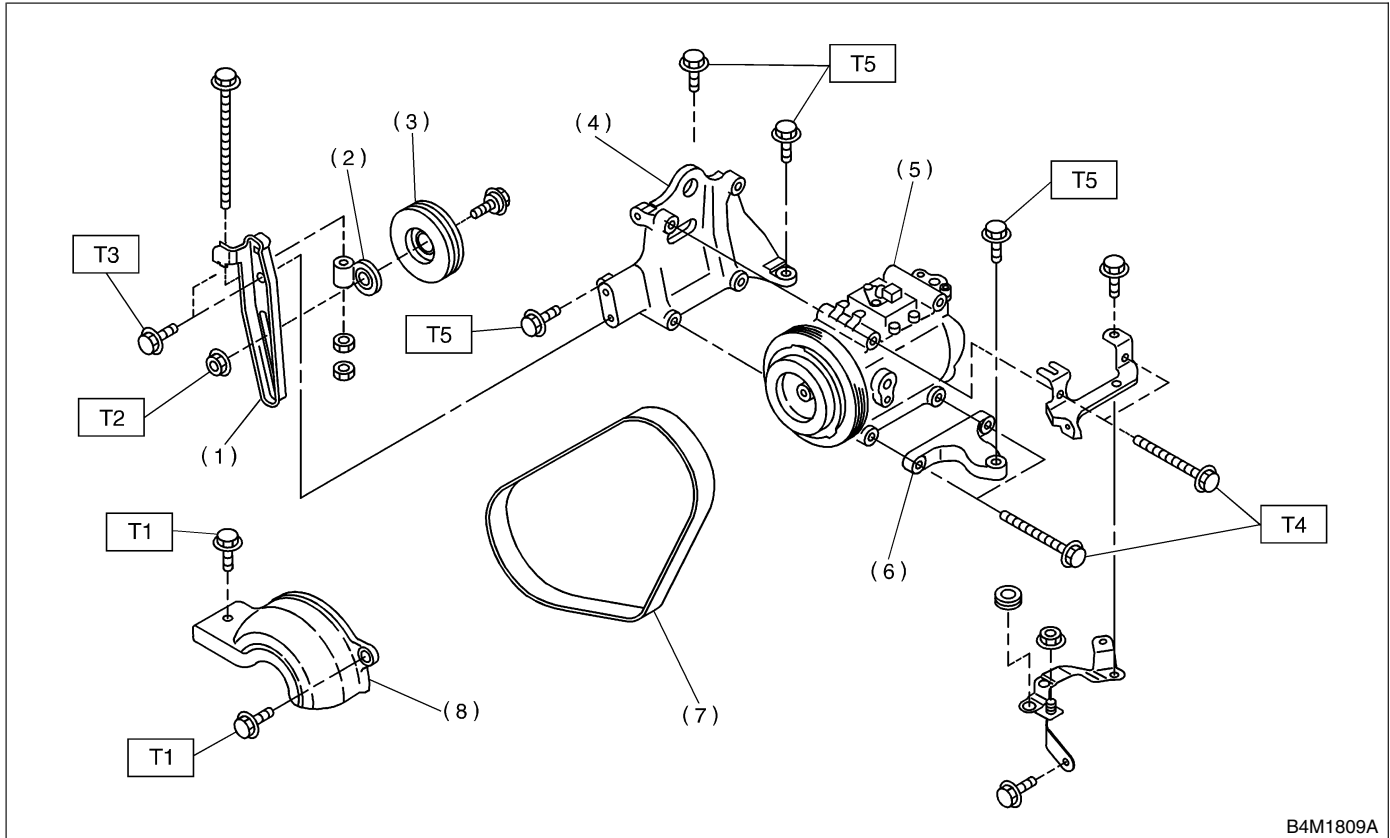

- (1) Idler pulley bracket
- (2) Idler pulley adjuster
- (3) Idler pulley
- (4) Compressor bracket upper
- (5) Compressor
- (6) Compressor bracket lower
- (7) V-belt
- (8) Compressor belt cover

Tightening torque: N-m (kgf-m, ft-lb)

T1: 7.4 (0.75, 5.4)

T2: 23 (2.3, 17)

T3: 23.0 (2.35, 17.0)

T4: 28.9 (2.95, 21.3)

T5: 35 (3.6, 26)

GENERAL DESCRIPTION

HVAC System (Heater, Ventilator and A/C)

C: CAUTION S701001A03

1. HFC-134a A/C SYSTEM S701001A0301

- Unlike the old conventional HFC-12 system components, the cooling system components for the HFC-134a system such as the refrigerant and compressor oil are incompatible.
- Vehicles with the HFC-134a system can be identified by the label "A" attached to the vehicle. Before maintenance, check which A/C system is installed in the vehicle.

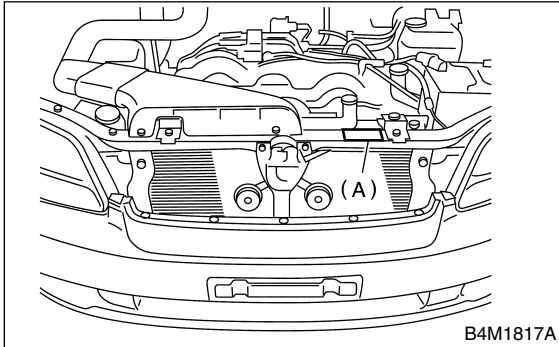

2. COMPRESSOR OIL S701001A0302

- HFC-134a compressor oil has no compatibility with that for R12 system.
- Use only the manufacturer-authorized compressor oil for the HFC-134a system; only use ZXL200PG.
- Do not mix multiple compressor oils. If HFC-12 compressor oil is used in a HFC-134a A/C system, the compressor may become stuck due to poor lubrication, or the refrigerant may leak due to swelling of rubber parts. On the other hand, if HFC-134a compressor oil is used in a HFC-12 A/C system, the durability of the A/C system will be lowered.
- HFC-134a compressor oil is very hygroscopic. When replacing or installing/removing A/C parts, immediately isolate the oil from the atmosphere using a plug or tape. In order to avoid moisture, store the oil in a container with its cap tightly closed.

3. REFRIGERANT S701001A0303

- The HFC-12 refrigerant cannot be used in the HFC-134a A/C system. The HFC-134a refrigerant, also, cannot be used in the HFC-12 A/C system.
- If an incorrect or no refrigerant is used, poor lubrication will result and the compressor itself may be damaged.

4. HANDLING OF REFRIGERANT S701001A0304

- The refrigerant boils at approx. -30°C (-22°F). When handling it, be sure to wear safety goggles and protective gloves. Direct contact of the refrigerant with skin may cause frostbite. If the refrigerant gets into your eye, avoid rubbing your eyes with your hands. Wash your eye with plenty of water, and receive medical treatment from an eye doctor.
- Do not heat a service can. If a service can is directly heated, or put into boiling water, the inside pressure will become extremely high. This may cause the can to explode. If a service can must be warmed up, use hot water in 40°C (104°F) max.
- Do not drop or impact a service can. (Observe the precautions and operation procedure described on the refrigerant can.)
- When the engine is running, do not open the high-pressure valve of the manifold gauge. The high-pressure gas will back-flow resulting in an explosion of the can.
- The refrigerant is non-toxic and harmless under normal operating circumstance, but it may change to phosgene (a noxious fume) under open flames or high temperatures (caused by a cigarette or heater).
- Provide good ventilation and do not work in a closed area.
- Never perform a gas leak test using a halide torch-type leak tester.
- In order to avoid destroying the ozone layer, prevent HFC-134a from being released into the atmosphere. Using a refrigerant recovery system, discharge and reuse it.

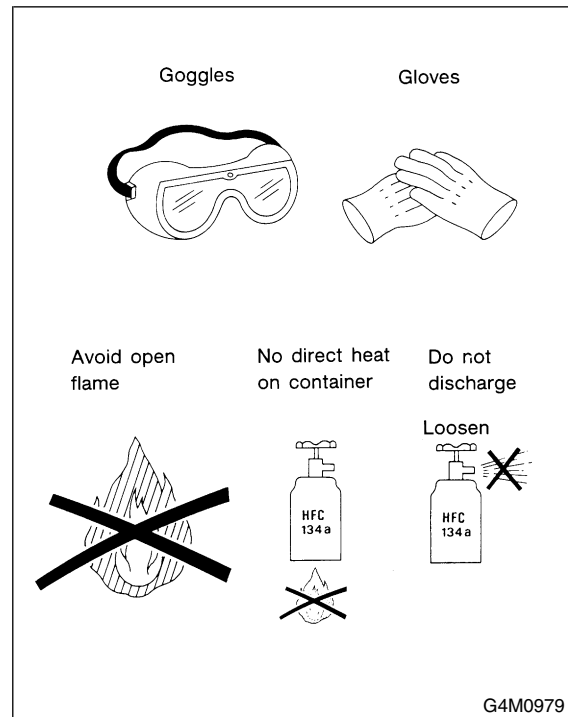

GENERAL DESCRIPTION

HVAC System (Heater, Ventilator and A/C)

5. O-RING CONNECTIONS S701001A0305

- Use new O-rings.
- In order to keep the O-rings free of lint which will cause a refrigerant gas leak, perform operations without gloves and shop towels.
- Apply the compressor oil to the O-rings to avoid sticking, then install them.
- Use a torque wrench to tighten the O-ring fittings: Over-tightening will damage the O-ring and tube end distortion.
- If the operation is interrupted before completing a pipe connection, recap the tubes, components, and fittings with a plug or tape to prevent contamination from entering.

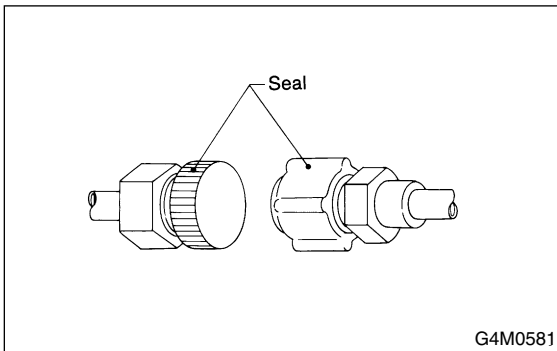

- Visually check the surfaces and mating surfaces of O-rings, threads, and connecting points. If a failure is found, replace the applicable parts.
- Install the O-rings at right angle to the tube beads.

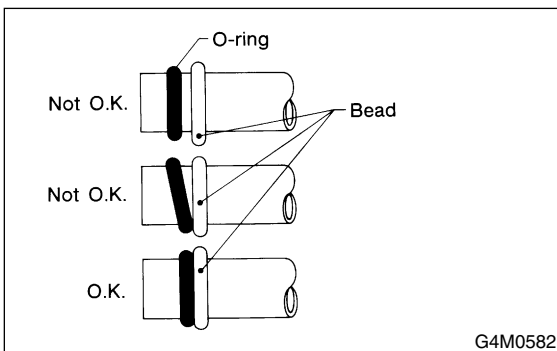

- Use the oil specified in the service manual to lubricate the O-rings. Apply the oil to the top and sides of the O-rings before installation. Apply the oil to the area including the O-rings and tube beads.

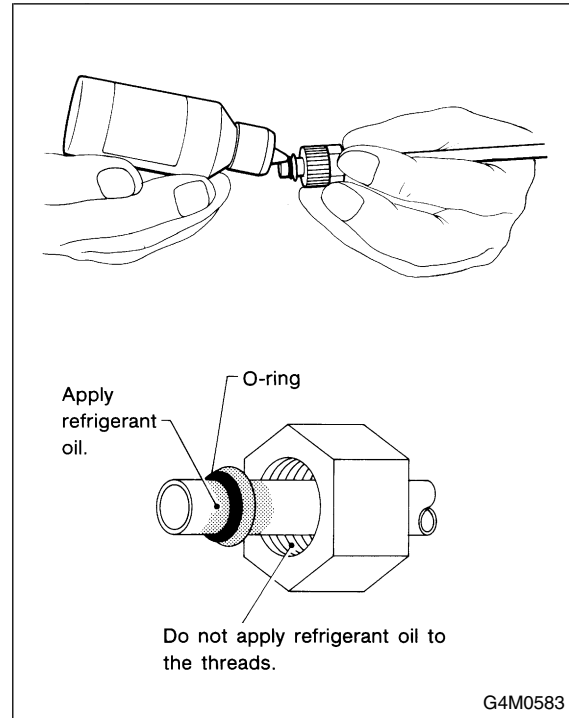

- When connecting hoses or pipes, use 2 wrenches (a torque wrench for tightening). While securing one side with a wrench, tighten the other side to the specified torque with a torque wrench. If only one wrench is used to tighten, the tightening torque will be excessive or insufficient. This may cause a pipe distortion or gas leak, resulting in damage to hoses and pipes.
- After tightening, using a clean shop towel to remove excess oil from the connections and any oil which may have run on the vehicle body or other parts.
- If any leakage is suspected after tightening, do not retighten the connections, Disconnect the connections, remove the O-rings, and check the O-rings, threads, and connections.

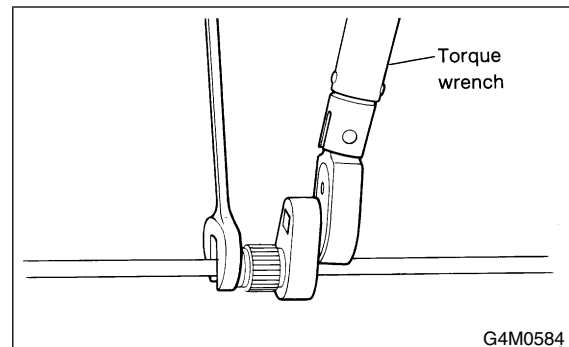

GENERAL DESCRIPTION

HVAC System (Heater, Ventilator and A/C)

D: PREPARATION TOOL S701001A17

CAUTION:

When working on vehicles with the HFC-134a system, only use HFC-134a specified tools and parts. Do not mix with CFC-12 tools and parts. If HFC-134a and CFC-12 refrigerant or compressor oil is mixed, poor lubrication will result and the compressor itself may be destroyed. In order to help prevent mixing HFC-134a and CFC-12 parts and liquid, the tool and screw type and the type of service valves used are different. The gas leak detectors for the HFC-134a and CFC-12 systems must also not be interchanged.

	HFC-134a	CFC-12
Tool & screw type	Millimeter size	Inch size
Valve type	Quick joint type	Screw-in type

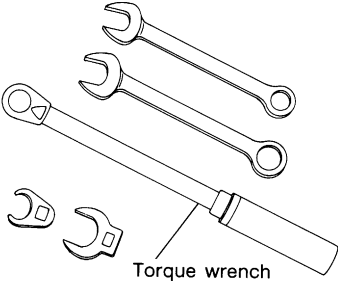
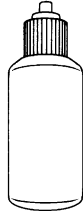
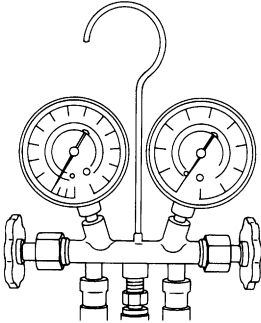
Tools and Equipment	Description
<p>Wrench</p> <p>Various WRENCHES will be required to service any A/C system. A 7 to 40 N-m (0.7 to 4.1 kg-m, 5 to 30 ft-lb) torque wrench with various crowfoot wrenches will be needed. Open end or flare nut wrenches will be needed for back-up on the tube and hose fittings.</p>	 <p style="text-align: right;">G4M0571</p>
<p>Applicator bottle</p> <p>A small APPLICATOR BOTTLE is recommended to apply refrigerant oil to the various parts. They can be obtained at a hardware or drug store.</p>	 <p style="text-align: right;">G4M0572</p>
<p>Manifold gauge set</p> <p>A MANIFOLD GAUGE SET (with hoses) can be obtained from either a commercial refrigeration supply house or from an auto shop equipment supplier.</p>	 <p style="text-align: right;">G4M0573</p>

GENERAL DESCRIPTION

HVAC System (Heater, Ventilator and A/C)

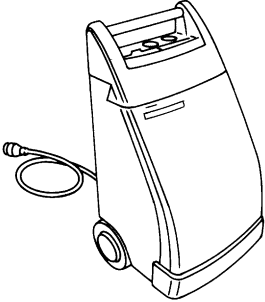
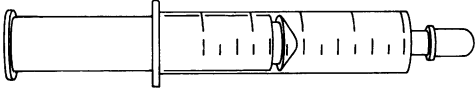
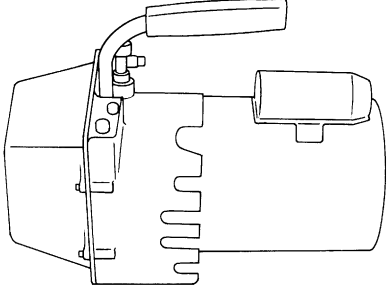
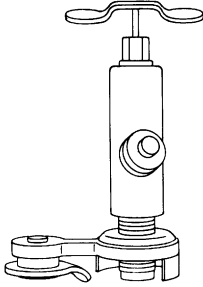
Tools and Equipment	Description
<p>Refrigerant recovery system</p> <p>A REFRIGERANT RECOVERY SYSTEM is used for the recovery and reuse of A/C system refrigerant after contaminants and moisture have been removed from the refrigerant.</p>	 <p>G4M0574</p>
<p>Syringe</p> <p>A graduated plastic SYRINGE will be needed to add oil back into the system. The syringe can be found at a pharmacy or drug store.</p>	 <p>G4M0575</p>
<p>Vacuum pump</p> <p>A VACUUM PUMP (in good working condition) is necessary, and may be obtained from either a commercial refrigeration supply house or an automotive equipment supplier.</p>	 <p>G4M0576</p>
<p>Can tap</p> <p>A CAN TAP for the 397 g (14 oz) can is available from an auto supply store.</p>	 <p>G4M0577</p>

GENERAL DESCRIPTION

HVAC System (Heater, Ventilator and A/C)

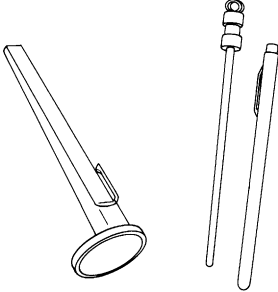
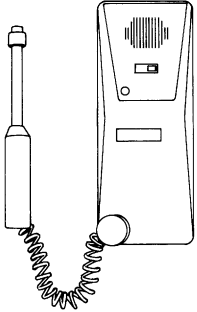
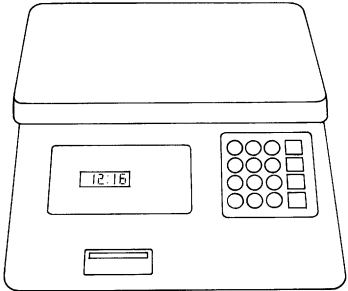
Tools and Equipment	Description
<p>Thermometer</p> <p>Pocket THERMOMETERS are available from either industrial hardware store or commercial refrigeration supply houses.</p>	 <p>G4M0578</p>
<p>Electronic leak detector</p> <p>An ELECTRONIC LEAK DETECTOR can be obtained from either a specialty tool supply or an A/C equipment supplier.</p>	 <p>G4M0579</p>
<p>Weight scale</p> <p>A WEIGHT SCALE such as an electronic charging scale or a bathroom scale with digital display will be needed if a 13.6 kg (30 lb) refrigerant container is used.</p>	 <p>G4M0580</p>