

## ELECTROHYDRAULIC CONTROL SYSTEM

Automatic Transmission

### 2. Electrohydraulic Control System

#### A: GENERAL

##### 1. MPT MODELS

The electrohydraulic control system for the transmission and transfer consists of various sensors and switches, a transmission control module (TCM) and the hydraulic controlling units including solenoid valves. The system controls the automatic transmission operation, including gear shifting, lock-up clutch operation, line pressure, automatic control pattern selection (“Base” and “Power”), and gear-shift timing. It also controls the operation of the transfer clutch. The TCM determines vehicle operating conditions from various input signals and controls a total of eight solenoids (shift solenoids 1 and 2, low clutch timing solenoid, 2-4 brake timing solenoid, line pressure duty solenoid, lock-up duty solenoid, transfer duty solenoid, and 2-4 brake duty solenoid) by sending appropriate signals to them.

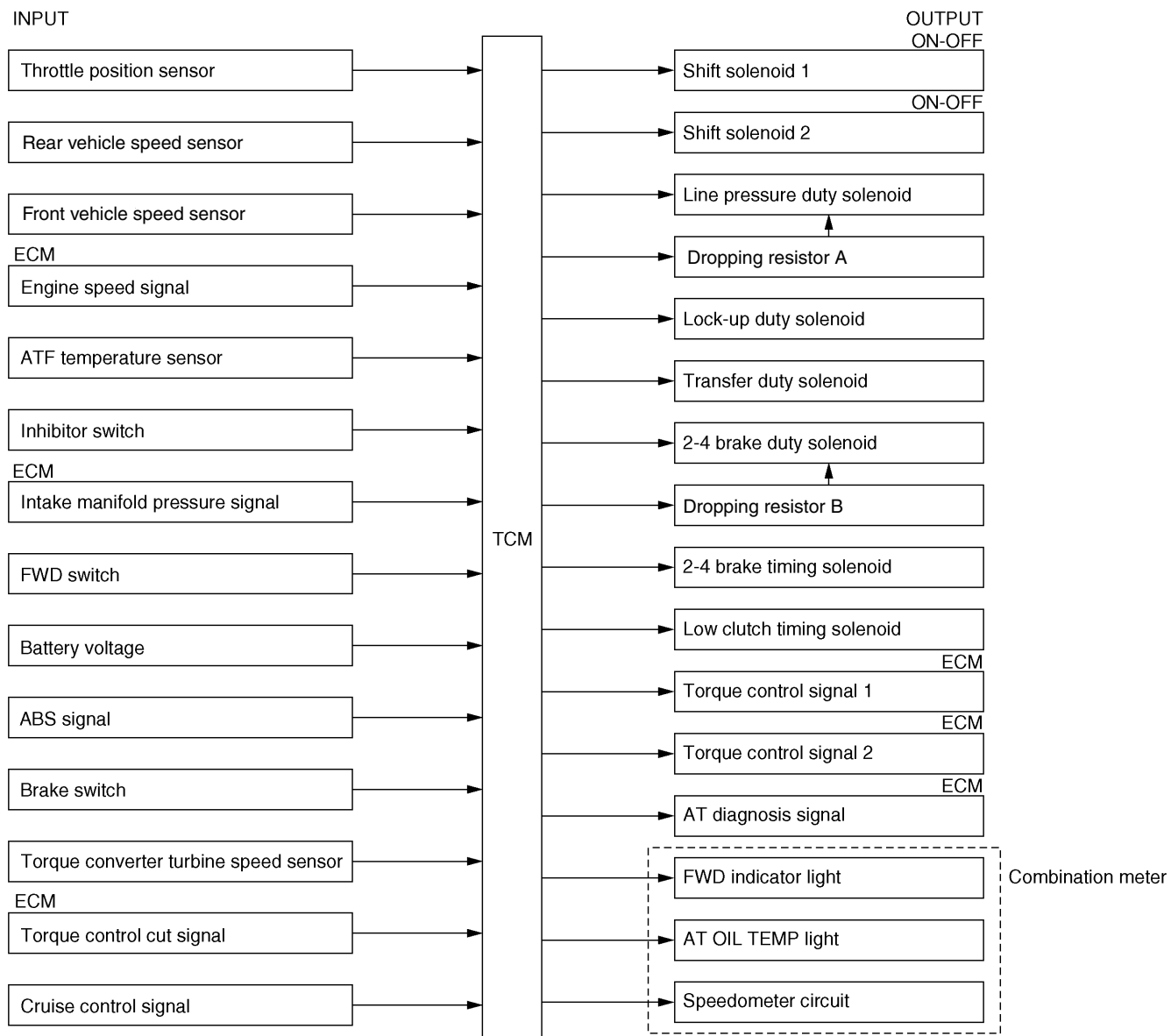

H3H1940B

AT-6

# ELECTROHYDRAULIC CONTROL SYSTEM

Automatic Transmission

## 2. VTD MODELS

The electrohydraulic control system for the transmission and transfer consists of various sensors and switches, a transmission control module (TCM) and the hydraulic controlling units including solenoid valves. The system controls the automatic transmission operation, including gear shifting, lock-up clutch operation, line pressure, automatic control pattern selection (“Base” and “Power”), and gear-shift timing. It also controls operation of the transfer multi-plate clutch (LSD). The TCM determines vehicle operating conditions from various input signals and controls a total of eight solenoids (shift solenoids 1 and 2, low clutch timing solenoid, 2-4 brake timing solenoid, line pressure duty solenoid, lock-up duty solenoid, transfer duty solenoid, and 2-4 brake duty solenoid) by sending appropriate signals to them.

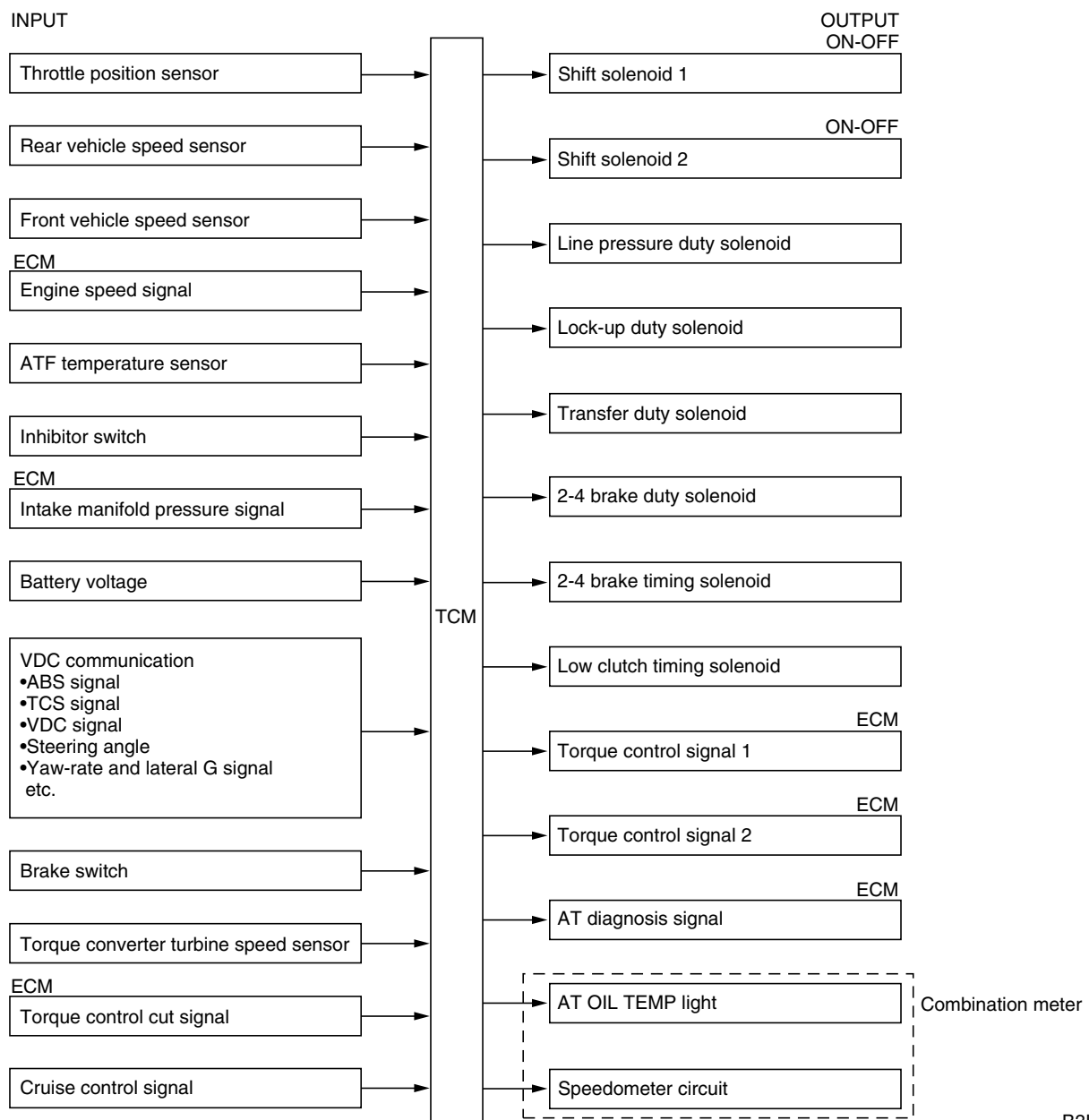

B3H2239A

## ELECTROHYDRAULIC CONTROL SYSTEM

Automatic Transmission

### B: INPUT SIGNALS

Signal name	Major function
Throttle position sensor	Indicates the throttle valve position. This signal is used to determine shift point, line pressure, and lock-up engaging vehicle speed, which vary with engine load.
Front vehicle speed sensor (located on transmission case)	Indicates the vehicle speed. This signal is used for control of gear shifting, lock-up engaging, line pressure, and transfer clutch operation.
Rear vehicle speed sensor (located on extension case)	Used to control transfer clutch, and also as backup signal in case of failure of front vehicle speed sensor.
Engine speed signal	Indicates the engine speed. This signal is used for control of lock-up clutch to ensure smooth engagement.
Inhibitor switch	Used to determine gears and line pressures in each of ranges "P", "R", "N", "D", "3", "2" and "1".
ATF temperature sensor	Indicates the ATF temperature. This signal is used for inhibition of lock-up, release of OD and determination of ATF temperature.
FWD switch (MPT models)	Used to change the mode from AWD to FWD. Also used to adapt the vehicle to FWD tester roller. Changeover from AWD to FWD can be made by inserting a fuse into the fuse holder.
ABS signal	Used when ABS is operating to optimize ABS control. In this control, transfer clutch torque load capacity is adjusted to eliminate the influence of engine braking and reduce the degree of coupling between front and rear wheels.
Cruise control signal	Indicates operation of cruise control system. It is used to expand "4th" operating range.
Torque converter turbine speed sensor	Tells the rotation speed of the input shaft. The proportion of this speed to the vehicle speed determines whether shifting should be made or not.
Torque control cut signal	Sent from engine control module (ECM) to TCM to inhibit the torque control.
Intake manifold pressure signal	Used to determine line pressure of gear shifting.
TCS signal (VTD models)	Used when TCS is operating to optimize TCS control. In this control, transfer clutch torque is controlled to eliminate the influence of engine braking and reduce the degree of coupling between front and rear wheels.
VDC signal (VTD models)	Used when VDC is operating to optimize VDC control. In this control, transfer clutch torque is controlled to eliminate the influence of engine braking and reduce the degree of coupling between front and rear wheels.
Steering angle sensor (VTD models)	Used to monitor the vehicle behavior and send signals for transfer control.
Yaw-rate and lateral G sensor (VTD models)	Used to monitor the vehicle behavior and send signals for transfer control.
Brake switch	If this signal is issued during downhill driving, TCM makes shift down control, causing the vehicle speed to be reduced.

AT-8

## ELECTROHYDRAULIC CONTROL SYSTEM

Automatic Transmission

### C: OUTPUT SIGNALS

Signal name	Function
Shift solenoid 1, 2	Each of these signals controls shift step by turning the corresponding solenoid ON/OFF. Activating timing is controlled for each solenoid to reduce shift shock.
Line pressure duty solenoid	Regulates the line pressure according to driving conditions.
Lock-up duty solenoid	Regulates the hydraulic pressure of the lock-up clutch to operate it in three modes (open, smooth and lock-up).
Transfer duty solenoid	Regulates the hydraulic pressure of the transfer clutch to control the driving force to the rear drive shaft.
AT OIL TEMP light	Causes the light to illuminate when ATF becomes excessively hot (exceeds a set temperature level). This light is also used for on-board diagnostics.
2-4 brake duty solenoid	Regulates 2-4 brake operating pressure to reduce shifting shocks.
2-4 brake timing solenoid	Switches on or off the pressure acting on 2-4 brake timing valve B to control the release timing of the 2-4 brake.
Low clutch timing solenoid	Switches on or off the pressure acting on the low clutch timing valve B to control the release timing of the low clutch. Also switches on or off the pressure acting on the reverse inhibit valve to control the reverse inhibit function.
Torque control signal 1	Reduces engine torque during range selection and gear change.
Torque control signal 2	Reduces engine torque during range selection and gear change.

## ELECTROHYDRAULIC CONTROL SYSTEM

### Automatic Transmission

## D: CONTROL ITEMS

### 1. MPT MODELS

Control item		Description of control	
Transmission control	Gear shift control	Base shift control ● Base pattern ● Power pattern	Upshifting and downshifting are set for each range, gear and pattern according to throttle position and vehicle speed.
		ABS-in-operation control	Gear is locked in 3rd when ABS signal enters.
		ATF-low-temperature control	Shifting into 4th gear is prevented when ATF temperature is below the preset value.
	Automatic pattern select control	Power pattern control	Power pattern is selected when throttle opening is changed at a speed exceeding the preset value.
		Base pattern control	When throttle opening is changed at a speed less than the preset value, Base pattern is resumed.
	Lock-up control	Base lock-up control	Lock-up ON is set for D-range 4th gear; ON/OFF is set for all gears (except D-range 4th) and patterns. Lock-up control is performed according to throttle position and vehicle speed. (Basically lock-up is OFF during gear shifting.)
		Smooth control	Smooth lock-up is performed when lock-up is switched on.
	Line pressure control	Ordinary control	Line pressure is regulated according to throttle position, vehicle speed and range signals.
		Shifting control	Line pressure is regulated when shifting to lessen shifting shock.
		Starting control	Line pressure is lowered to a minimum so as to reduce engine cranking load.
	Shift timing control	Shift step control	ON/OFF timing for shift solenoid is controlled.
		Lock-up control	When shifting, the lock-up clutch is temporarily released.
		Line pressure control	When shifting, line pressure is controlled to the optimum level so as to reduce shifting shock.
AWD transfer clutch control	Ordinary transfer control	Transfer clutch pressure is regulated according to the throttle valve angle and vehicle speed.	
	1 range control	Transfer clutch pressure is increased.	
	Slip control	Immediately after detecting a slip, transfer clutch pressure is controlled to the same pressure as 1 range. (This control is canceled if $V \geq 60$ km/h (37 MPH), or when throttle valve is closed fully.)	
	Control in turns	Transfer clutch pressure is reduced after detecting a turn.	
	ABS-in-operation control	Transfer clutch pressure is adjusted to a set level immediately after reception of ABS signal.	

## ELECTROHYDRAULIC CONTROL SYSTEM

Automatic Transmission

### 2. VTD MODELS

Control item		Description of control	
Transmission control	Gear shift control	Base shift control ● Base pattern ● Power pattern	Upshifting and downshifting are set for each range, gear and pattern according to throttle position and vehicle speed.
		ABS-in-operation control	Gear is locked in 3rd when ABS signal enters.
		ATF low temperature control	Shifting into 4th gear is prevented when ATF temperature is below the preset value.
	Automatic pattern select control	Power pattern control	Power pattern is selected when throttle opening is changed at a speed exceeding the preset value.
		Base pattern control	When throttle opening is changed at a speed less than the preset value, Base pattern is resumed.
	Lock-up control	Base lock-up control	Lock-up ON is set for D-range 4th gear; ON/OFF is set for all gears (except D-range 4th) and patterns. Lock-up control is performed according to throttle position and vehicle speed. (Basically lock-up is OFF during gear shifting.)
		Smooth control	Smooth lock-up is performed when lock-up is switched on.
	Line pressure control	Ordinary control	Line pressure is regulated according to throttle position, vehicle speed and range signals.
		Shifting control	Line pressure is regulated when shifting to lessen shifting shock.
		Starting control	Line pressure is lowered to a minimum so as to reduce engine cranking load.
	Shift timing control	Shift step control	ON/OFF timing for shift solenoid is controlled.
		Lock-up control	When shifting, the lock-up clutch is temporarily released.
		Line pressure control	When shifting, line pressure is controlled to the optimum level so as to reduce shifting shock.
AWD multi-plate clutch control (LSD)	Ordinary transfer control	Multi-plate clutch (LSD) pressure is regulated according to the torque input to the transfer and the driving condition.	
	Start control	When starting, the LSD pressure is adjusted proportionately to the throttle value angle.	
	Control in turns	When the front and rear wheel speed ratio is less than the set value for a vehicle speed, the LSD pressure is decreased.	
	Slip control	When a front or rear wheel starts slipping, the LSD pressure is decreased.	
	ABS-in-operation control	The LSD pressure is adjusted to the set level immediately after reception of ABS signal.	
	Base brake control	When the brake switch is ON and throttle valve is fully closed, the LSD pressure is lowered.	
	1 range control	The LSD pressure is increased to improve driveability.	

## ELECTROHYDRAULIC CONTROL SYSTEM

Automatic Transmission

### E: THROTTLE POSITION SENSOR

The throttle position sensor provides electrical signals corresponding to throttle valve positions. The throttle valve angular position and accelerator depressing speed are detected by this throttle position sensor.

### F: REAR VEHICLE SPEED SENSOR

#### 1. MPT MODELS

This vehicle speed sensor (output shaft speed sensor) is externally mounted on the extension case. It detects the rear wheel speed in terms of the peripheral speed of the transfer clutch drum and sends sine wave signals (30 pulses per rotation) to the TCM.

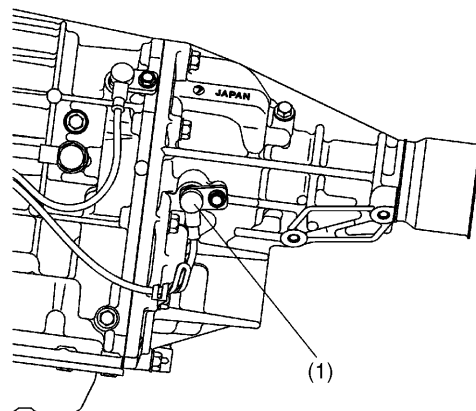

B3H0915C

(1) Rear vehicle speed sensor

#### 2. VTD MODELS

This vehicle speed sensor (output shaft speed sensor) is externally mounted on the extension case. It detects the rear wheel speed in terms of the peripheral speed of the rear drive shaft and sends sine wave signals (22 pulses per rotation) to the TCM.

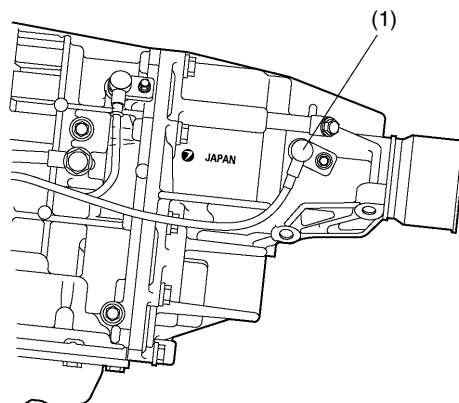

H3H1818C

(1) Rear vehicle speed sensor

AT-12

## ELECTROHYDRAULIC CONTROL SYSTEM

Automatic Transmission

### G: FRONT VEHICLE SPEED SENSOR

This vehicle speed sensor (output shaft speed sensor) is externally mounted on the transmission case. It detects the front wheel speed and sends sine wave signals (16 pulses per rotation) to the TCM.

The TCM converts the signals into 4-pulse signals and outputs them to both the engine control module (ECM) and the combination meter.

- MPT MODELS

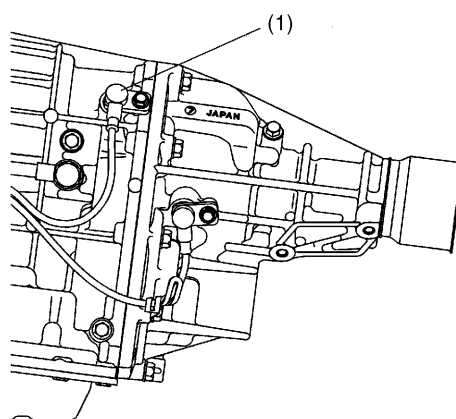

B3H0915D

(1) Front vehicle speed sensor

- VTD MODELS

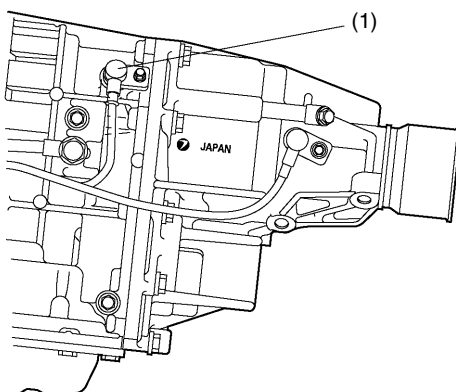

H3H1818D

(1) Front vehicle speed sensor

AT-13



## ELECTROHYDRAULIC CONTROL SYSTEM

Automatic Transmission

### H: ATF TEMPERATURE SENSOR

This sensor is located in the hydraulic control valve of the transmission. It detects the temperature of ATF and outputs it as an electrical resistance signal. The output characteristics of the sensor are shown below.

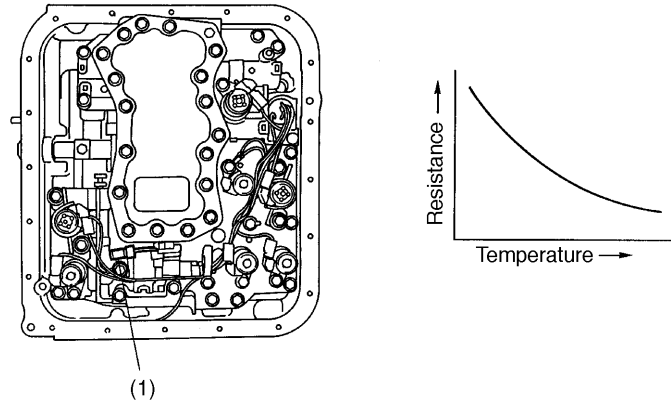

(1) ATF temperature sensor

B3H0916B

### I: TORQUE CONVERTER TURBINE SPEED SENSOR

The torque converter turbine speed sensor (output shaft speed sensor) is externally mounted on the transmission case.

The sensor detects the torque converter turbine speed in terms of the rotation speed of the periphery of the high clutch drum coupled to the input shaft, and sends sine wave signals (32 pulses per rotation) to the TCM. The TCM calculates the proportion of the input shaft speed to the vehicle speed and determines whether the shifting is to be made or not.

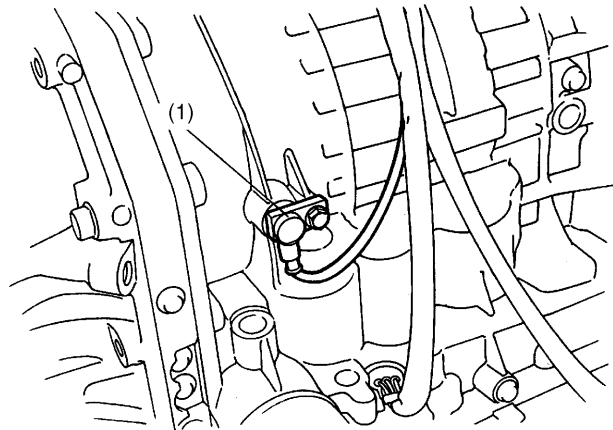

(1) Torque converter turbine speed sensor

B3H0999B

## ELECTROHYDRAULIC CONTROL SYSTEM

Automatic Transmission

### J: INHIBITOR SWITCH

The inhibitor switch assures safety when starting the engine. This switch is mounted on the right side of the transmission case, and is operated by the selector lever.

When the selector lever is set to P or N, the electrical circuit in the inhibitor switch is closed and the starter circuit is completed for cranking the engine.

When the selector lever is in the R, D, 3, 2 or 1 range, the electrical circuit in the inhibitor switch is open. Hence engine cranking is disabled. In the R range, the backup light circuit is completed in the switch, and the backup lights come on.

In addition to the above function, the inhibitor switch incorporates a circuit for detecting the selected range position and sending the range signal to the TCM.

Inhibitor switch side connector

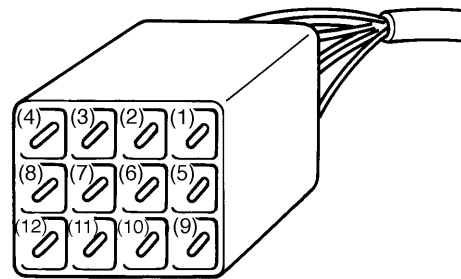

B3H0016B

Range position	Pin No.
P	(4) - (3) (12) - (11)
R	(4) - (2) (10) - (9)
N	(4) - (1) (12) - (11)
D	(4) - (8)
3	(4) - (7)
2	(4) - (6)
1	(4) - (5)

AT-15

## ELECTROHYDRAULIC CONTROL SYSTEM

Automatic Transmission

### K: SHIFT SOLENOIDS 1 AND 2

These solenoids are located in the transmission hydraulic control valve. They are turned ON or OFF according to signals from the TCM. The gear positions are changed according to the ON and OFF condition of these solenoids.

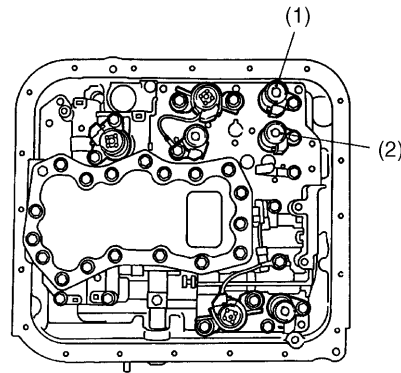

B3H0994J

- (1) Shift solenoid 2
- (2) Shift solenoid 1

### L: LOW CLUTCH TIMING SOLENOID

This solenoid is located in the transmission hydraulic control valve. It is turned ON or OFF according to signals from the TCM. It then controls the low clutch timing valve B and reverse inhibitor valve.

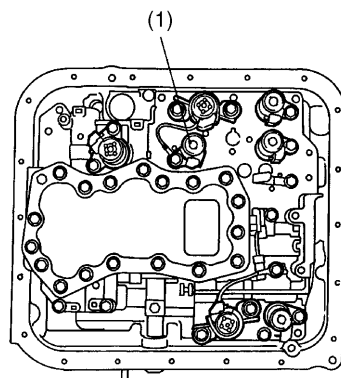

B3H0994K

- (1) Low clutch timing solenoid

AT-16

## ELECTROHYDRAULIC CONTROL SYSTEM

Automatic Transmission

### M: 2-4 BRAKE TIMING SOLENOID

This solenoid is located in the transmission hydraulic control valve. It is turned ON or OFF according to signals from the TCM. It then controls the 2-4 brake timing valve B to decrease the change gear shock.

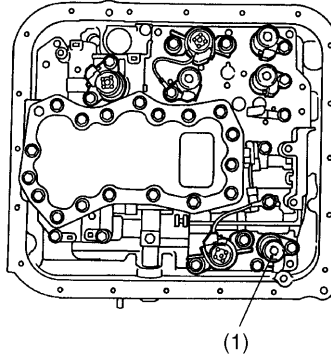

B3H0994L

(1) 2-4 brake timing solenoid

### N: LINE PRESSURE DUTY SOLENOID

This solenoid is located in the transmission hydraulic control valve. Its duty ratio is controlled by signals from the TCM. This solenoid then controls the pressure modifier valve and accumulator control valve A to adjust the line pressure to an optimum pressure level suitable for operating conditions.

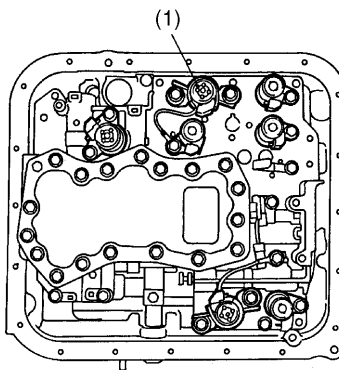

B3H0994M

(1) Line pressure duty solenoid

AT-17

## ELECTROHYDRAULIC CONTROL SYSTEM

Automatic Transmission

### O: LOCK-UP DUTY SOLENOID

This solenoid is located in the transmission hydraulic control valve. Its duty ratio is controlled by signals from the TCM. It then controls the lock-up control valve to provide smooth engagement and disengagement of the lock-up clutch.

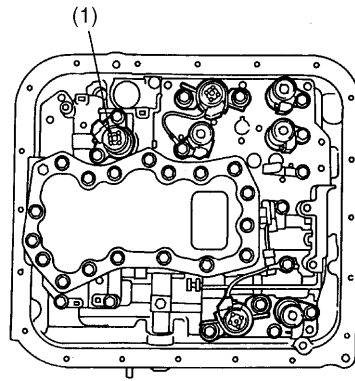

B3H0994N

(1) Lock-up duty solenoid

### P: 2-4 BRAKE DUTY SOLENOID

This solenoid is located in the transmission hydraulic control valve. Its duty ratio is controlled by signals from the TCM. It modulates the 2-4 brake pressure when the 2-4 brake is operated, reducing shifting shocks.

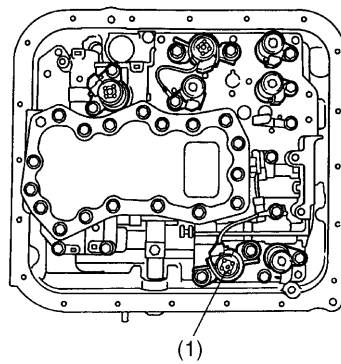

B3H0994O

(1) 2-4 brake duty solenoid

AT-18

## ELECTROHYDRAULIC CONTROL SYSTEM

Automatic Transmission

### Q: TRANSFER DUTY SOLENOID

This solenoid is located in the transfer hydraulic pressure control unit on the rear end of transmission case. Its duty ratio is controlled by signals from the TCM. It then controls the transfer clutch/control valve to control the pressure applied to the transfer clutch.

- MPT MODELS

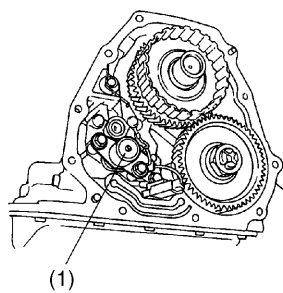

B3H0995C

(1) Transfer duty solenoid

- VTD MODELS

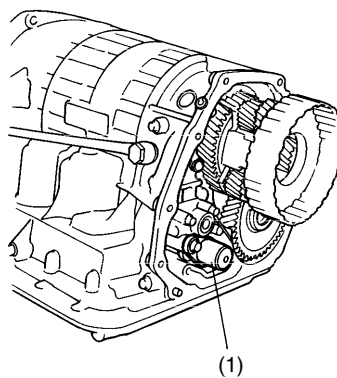

H3H1929C

(1) Transfer duty solenoid

AT-19