

BRAKE BOOSTER

Brakes

3. Brake Booster

- The brake booster is a tandem type that uses two diaphragms. This design provides high brake boosting effects in spite of a reduced diameter.
- All models are equipped with an 8 inch + 9 inch booster.

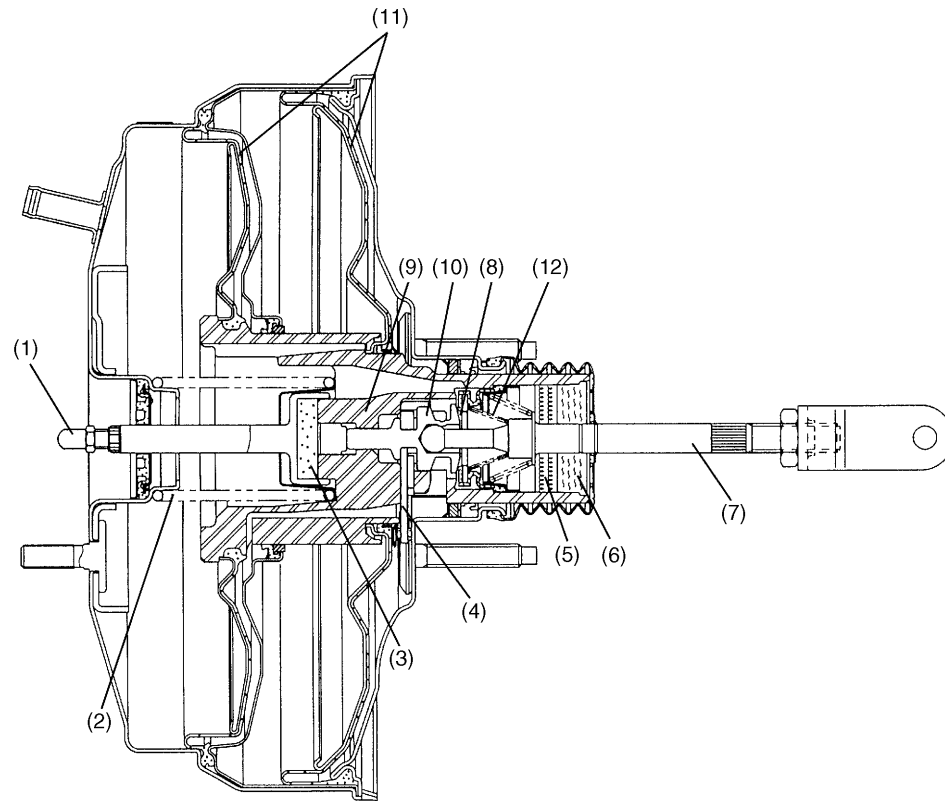

B4H1936A

- | | | |
|-------------------|-------------------|--------------------------|
| (1) Push rod | (5) Filter | (9) Valve body |
| (2) Return spring | (6) Silencer | (10) Plunger valve |
| (3) Reaction disc | (7) Operating rod | (11) Diaphragm plate |
| (4) Key | (8) Poppet valve | (12) Valve return spring |

BR-7