

## SHIFT LOCK SYSTEM

Control System

### 3. Shift Lock System

#### A: GENERAL

To increase safety during standing start, the shift lock system prevents movement of the select lever from the "P" position to any other position unless the brake pedal is depressed. This system is also provided with a key interlock function which prevents removal of the ignition key from the key cylinder unless the selector lever is placed in the "P" position.

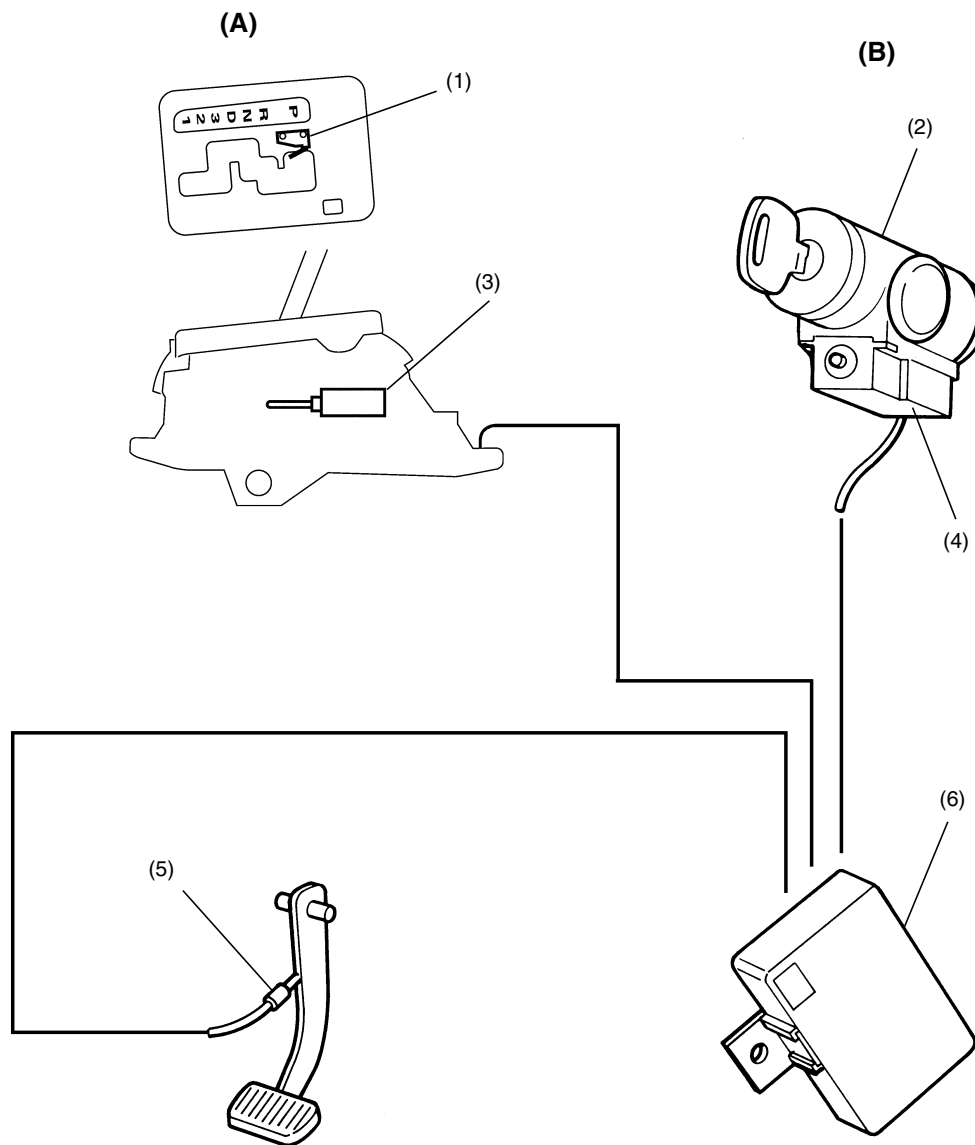

B3H2264A

(A) Shift lock system

(B) Key interlock system

(1) "P" position switch

(2) Key cylinder

(3) Shift lock solenoid

(4) Key lock solenoid

(5) Brake pedal switch

(6) Shift lock control module

CS-4

## SHIFT LOCK SYSTEM

Control System

### B: SHIFT LOCK SYSTEM OPERATION

The shift lock system has a solenoid-operated plunger (1). With the select lever in the "P" position, the plunger remains extended, holding the lock arm (2) in its raised (locking) position. When the brake pedal is depressed with the ignition switch in either the ON or START position, the solenoid is energized and the plunger is retracted. This causes the lock arm to tilt forward to the select lever release position. The select lever now can be moved to any other position. The "P" position of the select lever is detected by the "P" position switch (3).

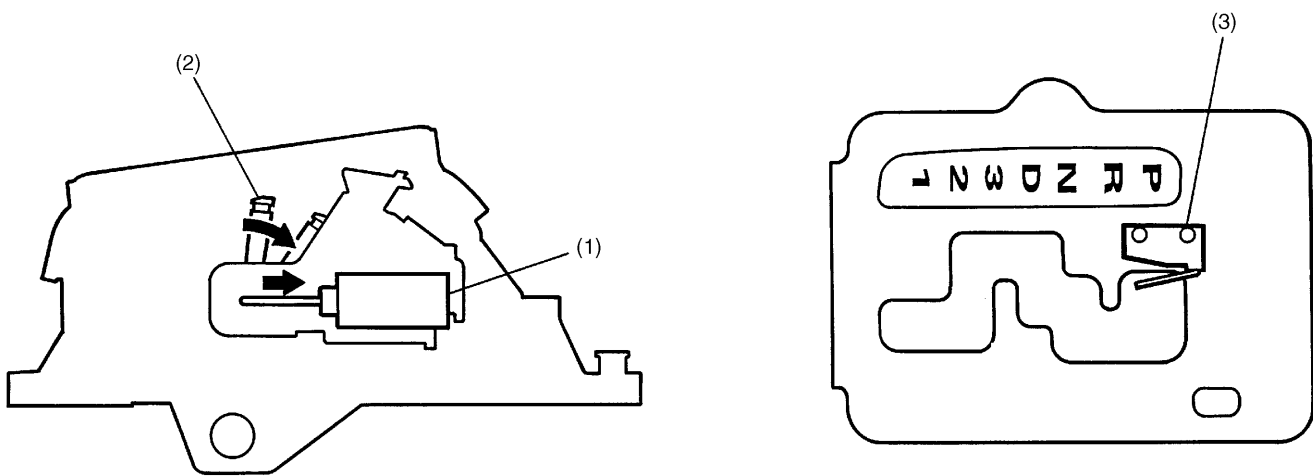

B3H1754A

- (1) Solenoid
- (2) Lock arm
- (3) "P" position switch

CS-5

## SHIFT LOCK SYSTEM

Control System

### C: KEY INTERLOCK FUNCTION

● When the select lever is at any position other than “P”, the solenoid is energized and its pin is held extended. Being caused to stay in its upright position by extension of the pin, the interlock lever interferes with the stopper portion of the rotator which turns together with the ignition key. Thus, the ignition key cannot be rotated to the “LOCK” position.

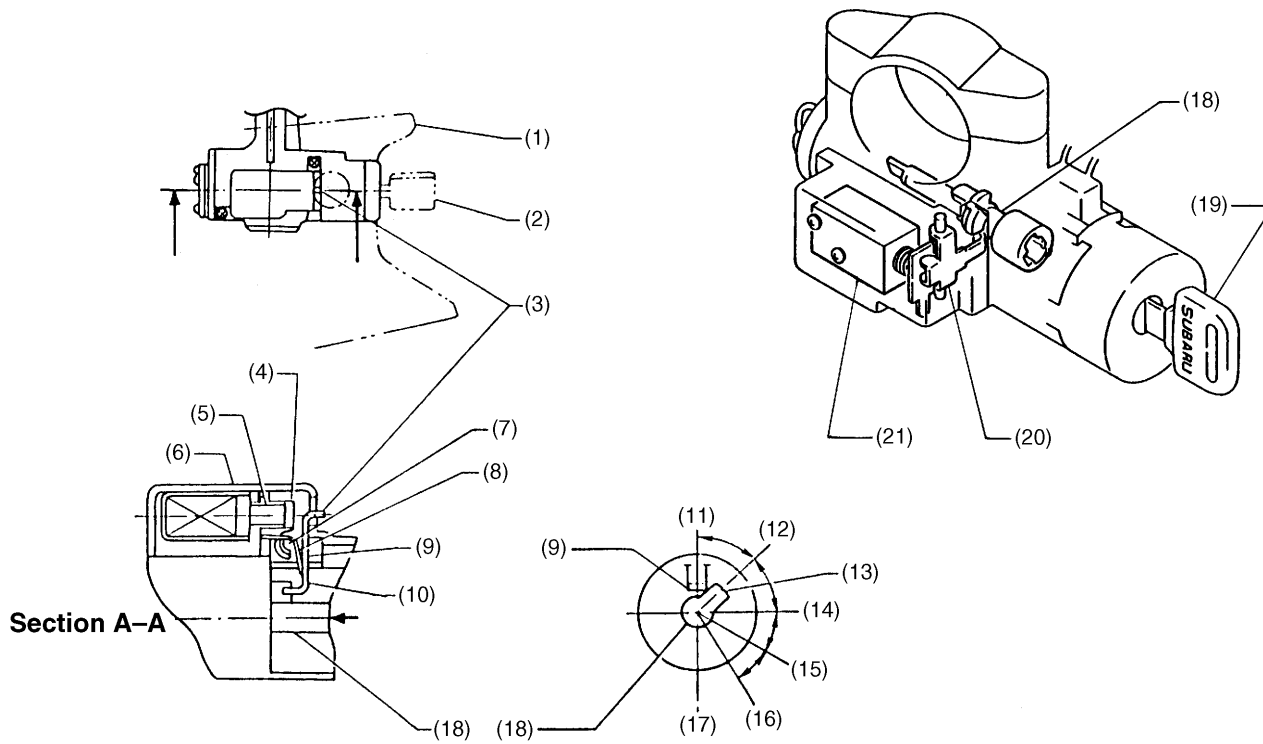

S3H0575A

- |                          |                         |
|--------------------------|-------------------------|
| (1) Column cover         | (12) Interlock position |
| (2) Key                  | (13) Stopper            |
| (3) Push button          | (14) ACC                |
| (4) Extended             | (15) ON                 |
| (5) Solenoid pin         | (16) START              |
| (6) Solenoid unit        | (17) View B             |
| (7) Lever fulcrum        | (18) Rotator            |
| (8) Lever spring         | (19) Key                |
| (9) Interlock lever      | (20) Interlock lever    |
| (10) Interlock activated | (21) Solenoid           |
| (11) LOCK                |                         |

CS-6

## SHIFT LOCK SYSTEM

Control System

- When the select lever is moved to “P”, the “P” position switch in the select lever assembly operates, deenergizing the solenoid. As the push force of the solenoid pin is removed, the lever spring causes the interlock lever to tilt and become clear of the rotator’s stopper. Then the key can be rotated to the “LOCK” position and removed from the ignition switch.

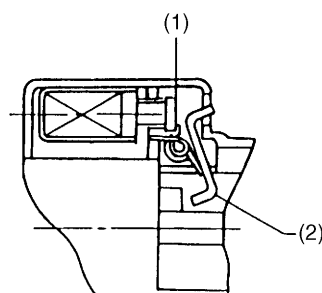

S3H0576A

- (1) Retracted
- (2) Interlock deactivated

CS-7

# SHIFT LOCK SYSTEM

Control System

---

**MEMO**

**CS-8**