

REAR DIFFERENTIAL

Differentials

1. Rear Differential

A: VA-TYPE

The drive gear is a hypoid gear with nominal diameter of 152 mm (5.98 in). The drive pinion shaft is supported by three bearings. The bearing preload is adjusted by selecting a spacer and washer combination of a proper thickness. The drive pinion height is adjusted by properly selecting the thickness of the washers located at the drive pinion neck using Dummy Shaft and Gauge.

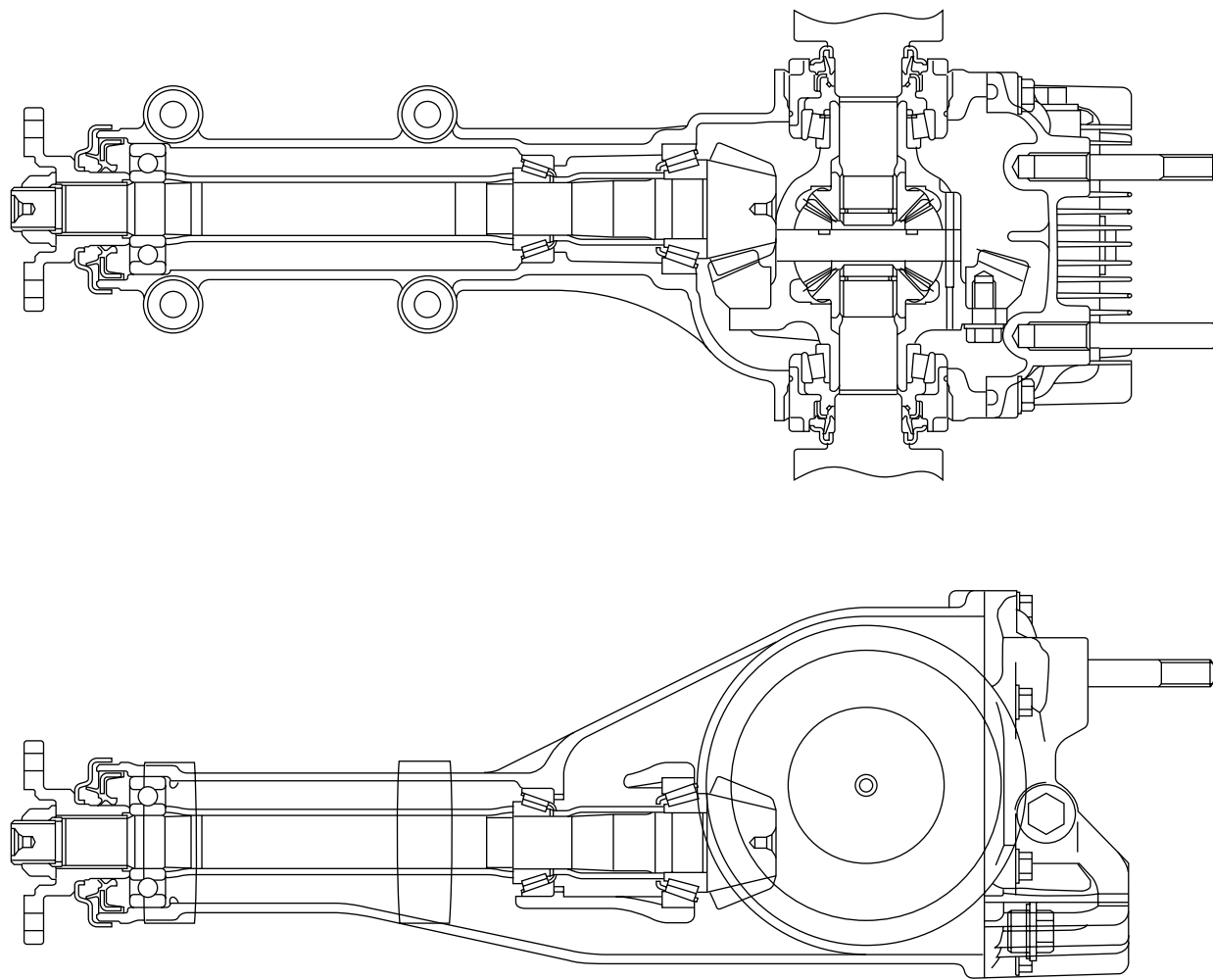

B3H2211

DI-2

REAR DIFFERENTIAL

Differentials

B: T-TYPE

The drive gear is a hypoid gear with a nominal diameter of 160 mm (6.30 in). The drive pinion shaft is supported by three bearings. The bearing preload is adjusted by selecting a spacer and washer combination of a proper thickness. The drive pinion height is adjusted by properly selecting the thickness of the washers located at the drive pinion neck using Dummy Shaft and Gauge.

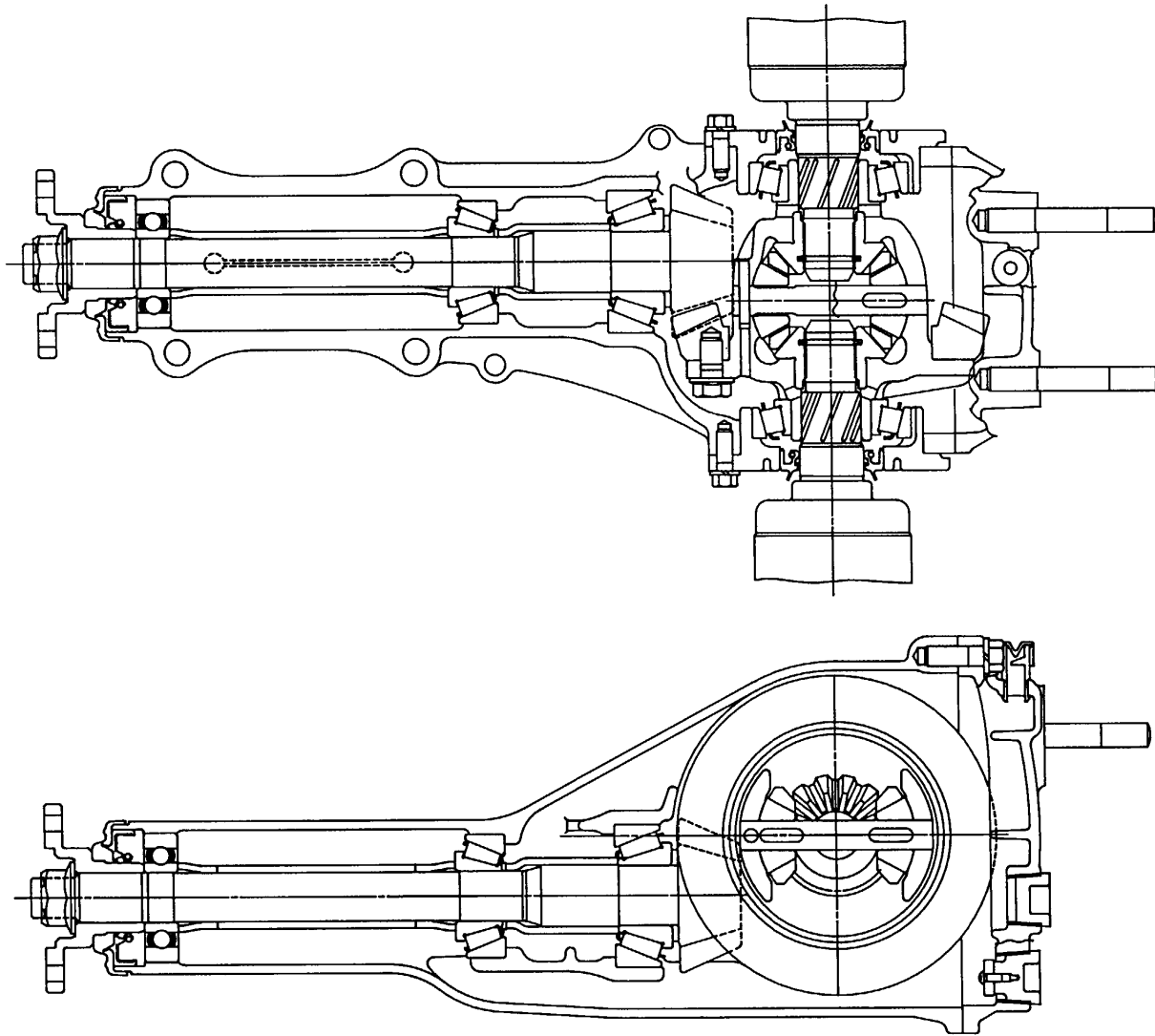

H3H1060

DI-3