

## LIMITED SLIP DIFFERENTIAL (LSD)

Differentials

### 2. Limited Slip Differential (LSD)

#### A: OUTLINE

The limited slip differential is of a viscous coupling (V/C) type which automatically limits the differential action and distributes torque to the left and right wheels adequately to enhance driving stability when the left and right wheels are rotating at speeds different from each other during driving on a slippery road (muddy, snow-covered or slushy road) or cornering.

#### B: STRUCTURE

The V/C type LSD has outer plates and inner plates arranged alternately. Each outer plate is splined to the inside of the differential case at its outer periphery and each inner plate is splined to the outer circumference of the left side gear at its inner periphery.

The inner plates are held in position by spacer rings while the outer rings can slide in the axial direction along the spline teeth.

The space between the differential case and the left side gear is filled with a mixture of high viscosity silicone oil and air and hermetically sealed with X-rings.

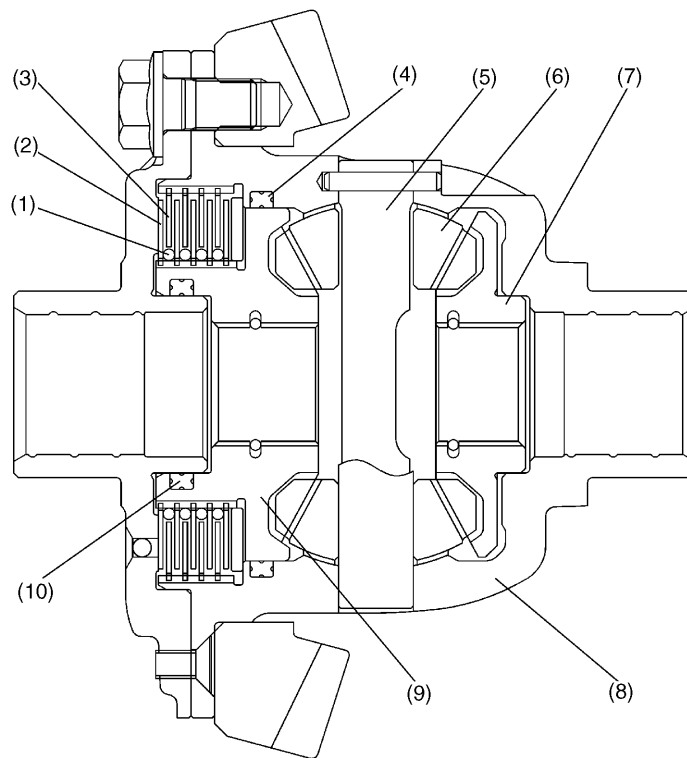

S3H0174B

- (1) Spacer ring
- (2) Inner plate
- (3) Outer plate
- (4) X-ring
- (5) Pinion shaft

- (6) Pinion gear
- (7) Side gear (right)
- (8) Differential case
- (9) Side gear (left)
- (10) X-ring

DI-4

## LIMITED SLIP DIFFERENTIAL (LSD)

Differentials

### C: OPERATION

#### 1. WHEN RIGHT AND LEFT WHEELS ROTATE AT THE SAME SPEED

During normal straight-ahead driving where the right and left wheels rotate at the same speed, the differential case and side gears rotate together, just as in conventional differentials. As a result, driving torque is distributed equally to the right and left side gears.

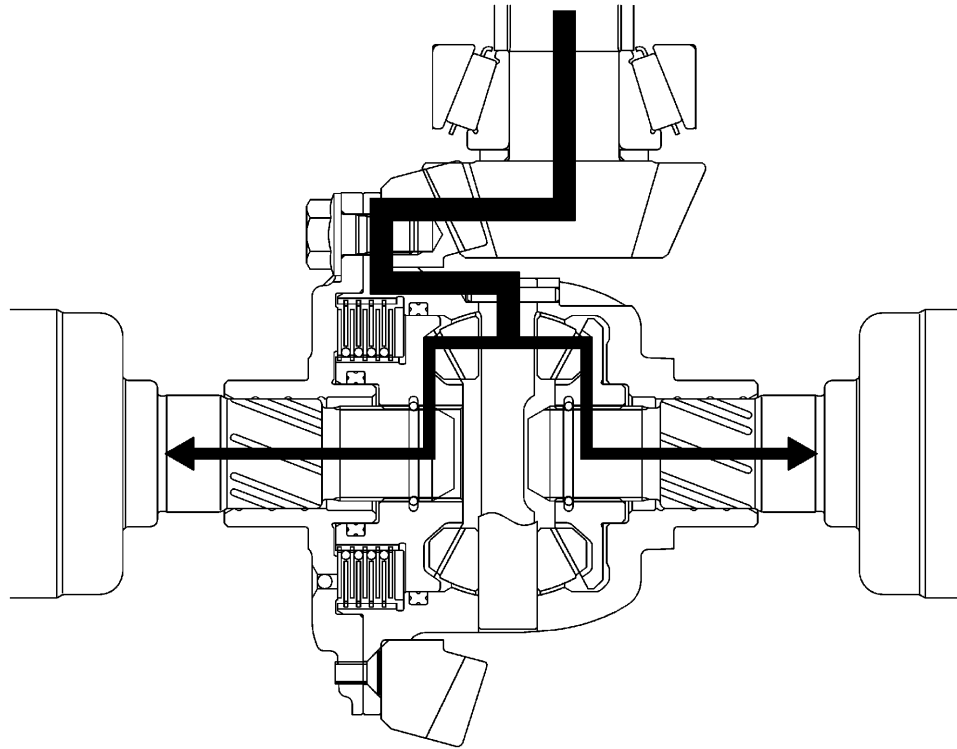

S3H0175

DI-5

## LIMITED SLIP DIFFERENTIAL (LSD)

### Differentials

#### 2. WHEN RIGHT AND LEFT WHEELS ROTATE AT DIFFERENT SPEEDS

When a speed difference occurs between the right and left wheels, the differential case and the left side gear do not rotate at the same speed any more. The speed difference between them corresponds to that between both the wheels. Because of the shear force caused in the silicone oil, a differential torque is then generated, which limits differential action.

For example, if the left wheel spins due to small road resistance, a speed difference occurs between the right and left wheels. Since there is the V/C between the differential case and left side gear, a differential torque corresponding to the speed difference is generated in the V/C. This differential torque is transferred from the left wheel to the right wheel. As a result, a greater driving torque is distributed to the right wheel which is rotating at a lower speed.

When the right wheel spins, the differential torque is transferred from the right wheel to the left wheel. Also in this case, a torque greater by the differential torque than the torque to the spinning wheel is transmitted to the wheel rotating at the lower speed.

#### When left wheel spins

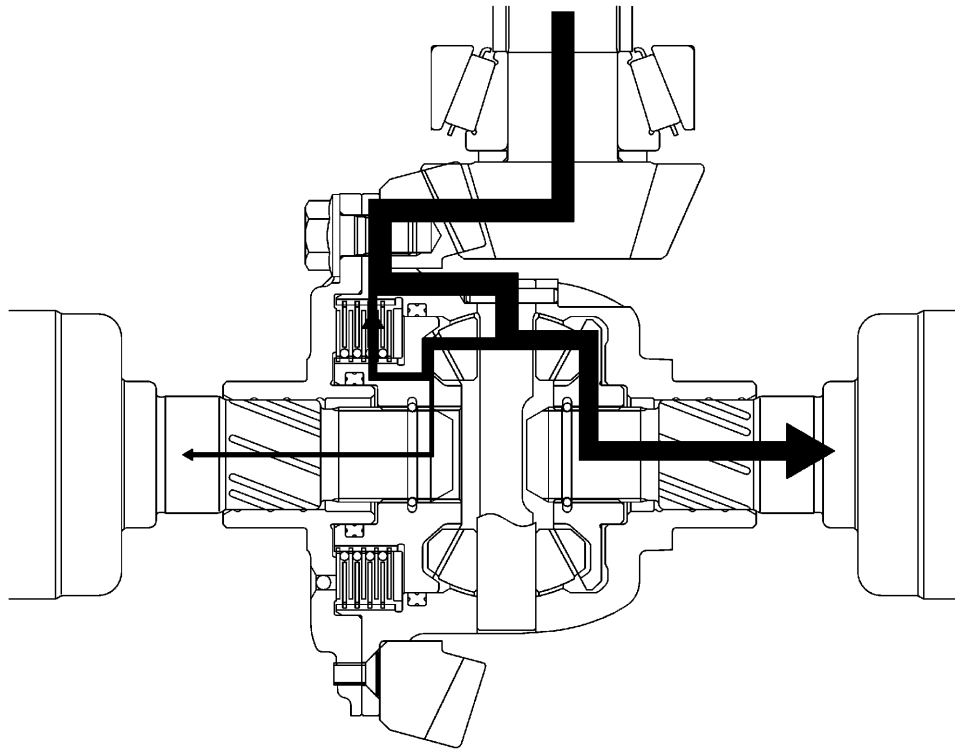

S3H0176

DI-6

## LIMITED SLIP DIFFERENTIAL (LSD)

Differentials

When right wheel spins

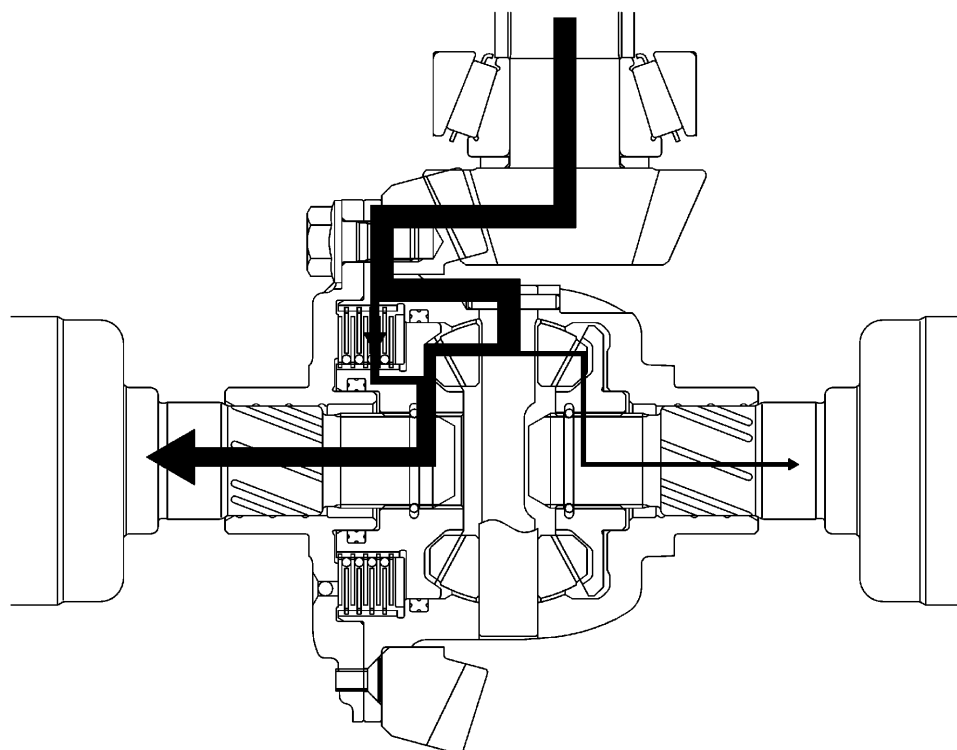

S3H0177

### D: SERVICE PROCEDURES FOR LSD

It is not recommended to disassemble the LSD assembly as component parts of LSD assembly are not available individually.

DI-7

## LIMITED SLIP DIFFERENTIAL (LSD)

Differentials

---

MEMO

DI-8