

AUTOMATIC AIR CONDITIONING

HVAC System (Heater, Ventilator and A/C)

17. Automatic Air Conditioning

A: SWITCH FUNCTIONS

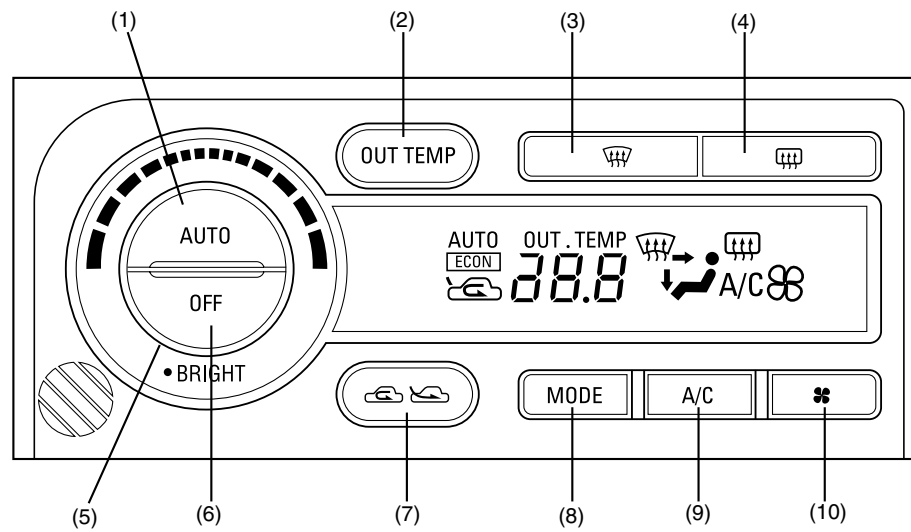

B4H2541A

- | | |
|--|--------------------------|
| (1) AUTO switch | (6) OFF/Bright switch |
| (2) Ambient temperature display switch | (7) Fresh/Recirc switch |
| (3) Defroster switch | (8) Mode selector switch |
| (4) Rear defogger switch | (9) A/C switch |
| (5) Temperature set switch | (10) Blower fan switch |

NOTE:

The beeper for button operation confirmation has been discontinued.

AUTOMATIC AIR CONDITIONING

HVAC System (Heater, Ventilator and A/C)

1. AUTOMATIC CONTROL OPERATION

- **AUTO switch:** When this switch is pressed (ON), the air outlet selection, blower fan speed, air temperature, fresh/recirculation switching, and compressor operation are automatically controlled. When the AUTO switch is pressed second time, the compressor operates in the ECON mode. In the ECON mode, the ECM controls compressor operation based on inputs from the intake air temperature sensor. Compressor operating time in the ECON mode is shorter than in the AUTO mode.

- **Temperature set switch:** A desired cabin temperature can be set in 0.5°C increments.

- **OFF/Bright switch:** When this switch is pressed, the blower fan and compressor stop and all the indicators go out.

Setting the light switch to the “ ☾ ” or “ ☽ ” position causes the illuminating icons on the display panel to dim. When traveling with the lights on in goomy daylight or in twilight, press the OFF switch for 1 second or longer if you feel it is too hard to identify the icons clearly. The brightness comes back to normal.

2. MANUAL CONTROL OPERATION

- **A/C switch:** The air-conditioner turns on when this switch is pressed first and turns off when it is pressed second time.

- **Blower fan switch:** Fan speed changes in the order of Lo, M1, M2 and Hi, every time it is pressed.

- **Ambient temperature display switch:** When this switch is pressed momentarily, the ambient temperature is indicated on the display for 5 seconds. When this switch is depressed for more than 1 seconds, the ambient temperature is continuously indicated.

- **Defroster switch:** When this switch is pressed, air flow is directed toward the windshield and side windows for defrosting, outside air is drawn into the passenger compartment, and the A/C compressor is engaged.

- **Rear deffogger switch:** Pressing this switch causes the rear deffogger to operate for 15 minutes.

- **Fresh/Recirc switch:** Every time this switch is pressed, switching takes place between outside air introduction and inside air recirculation alternately.

- **Mode selector switch:** Pressing this switch changes the outlets to which the air is directed in the order shown below.



B4H1314B

AC-30

AUTOMATIC AIR CONDITIONING

HVAC System (Heater, Ventilator and A/C)

B: CABIN TEMPERATURE SENSOR

The cabin temperature sensor sends signals to the ECM.

This sensor consists of an aspirator and a thermistor, the resistance of which changes in inverse proportion to the temperature. The aspirator uses the vacuum created by the heater unit to direct cabin air to the thermistor. (The cabin temperature sensor, therefore, functions only while the blower fan is in operation.)

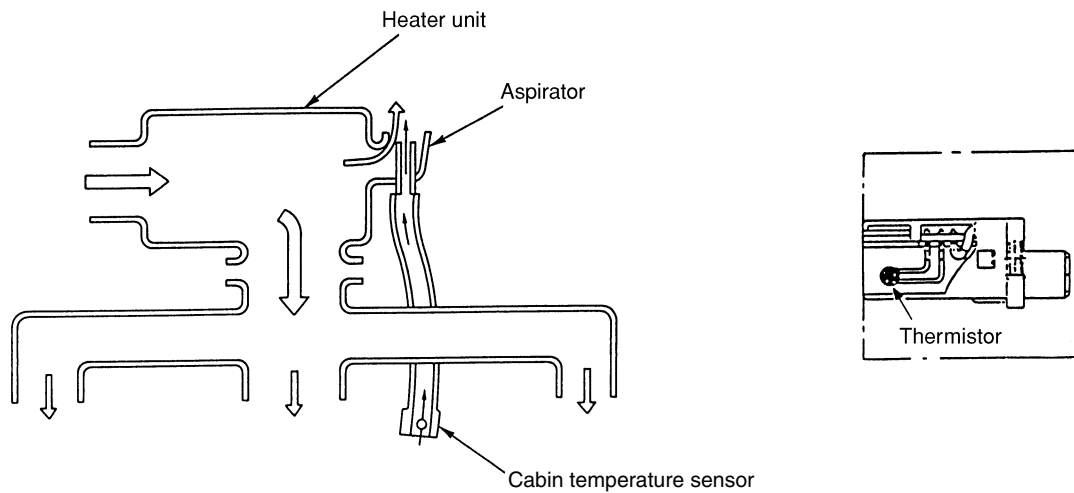

B4H1315B

C: AMBIENT TEMPERATURE SENSOR

This sensor uses a thermistor to detect the ambient temperature and sends signals to the ECM.

The thermistor can detect only an average temperature of the outside air but cannot respond to sharp changes in the temperature because its exterior is made of a plastic to increase the thermal capacity.

The ambient temperature sensor is located on the radiator stay behind the front grille for efficient exposure to the outside air.

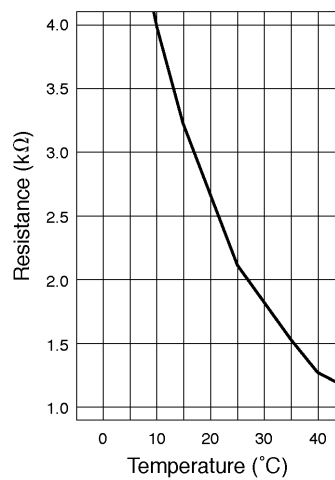

B4H1316B

AC-31

AUTOMATIC AIR CONDITIONING

HVAC System (Heater, Ventilator and A/C)

D: SUNLOAD SENSOR

A photodiode is used in the sunload sensor. The photodiode detects changes in the sunbeam intensity and converts the results into current signals to send to the ECM.

The sunload sensor is built into the front defroster grille.

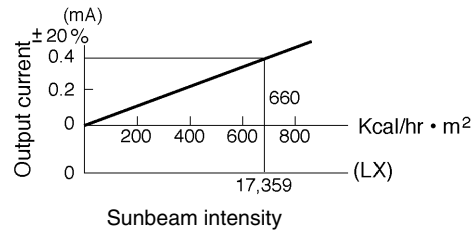
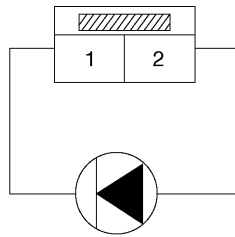

Sunbeam intensity and output current

B4H1317B

AC-32

AUTOMATIC AIR CONDITIONING

HVAC System (Heater, Ventilator and A/C)

E: AIR MIX SERVO MOTOR

According to signals from the ECM, the servo motor forming integral part of the air mix damper rotates in one or the other direction to change the opening of the damper via a link.

The motor has a built-in potentiometer which detects the opening of the air mix damper and sends the result to the ECM.

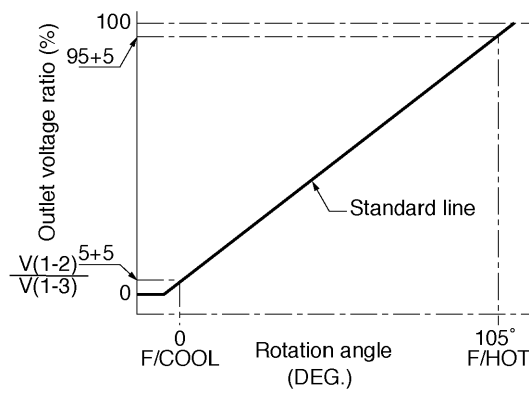
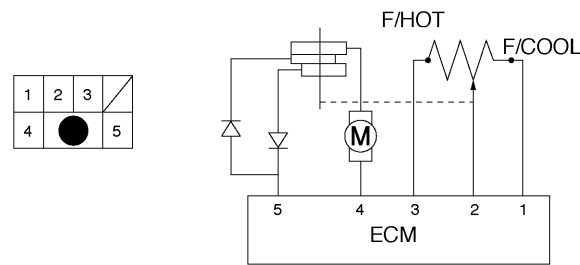

B4H1318B

AC-33

AUTOMATIC AIR CONDITIONING

HVAC System (Heater, Ventilator and A/C)

F: AIR OUTLET SWITCHING SERVO MOTORS

According to signals from the ECM, the servo motor incorporated into each air outlet switching damper rotates in one or the other direction to open or close the damper via a link to control the air from the corresponding outlet(s).

Each motor has a built-in potentiometer which detects the position of its damper and send the result to the ECM.

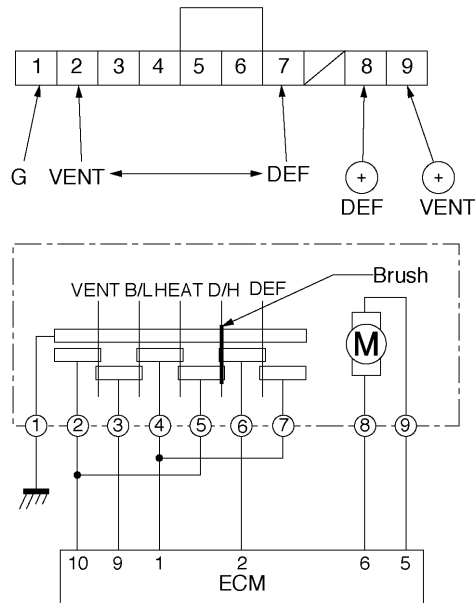

B4H1319B

G: FRESH/RECIRC SWITCHING SERVO MOTOR

According to signals from the ECM, the servo motor incorporated into the fresh/recirc switching damper rotates in one or the other direction to perform switching between the outside air introduction and inside air recirculation modes via a link.

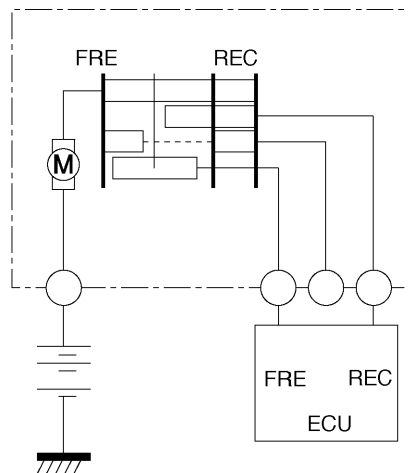

B4H1320B

AUTOMATIC AIR CONDITIONING

HVAC System (Heater, Ventilator and A/C)

H: BLOWER SPEED CONTROL POWER TRANSISTOR

The base voltage of the power transistor changes according to blower drive signals from the ECM. The blower speed changes steplessly in accordance with the change in the power transistor's base voltage.

Should an over-current occur, the thermal fuse connected to the circuit (rated to blow at 144°C (291°F)) cuts off the current to the blower.

I: EVAPORATOR SENSOR

The evaporator sensor detects the temperature at the evaporator outlet and sends the result to the ECM.

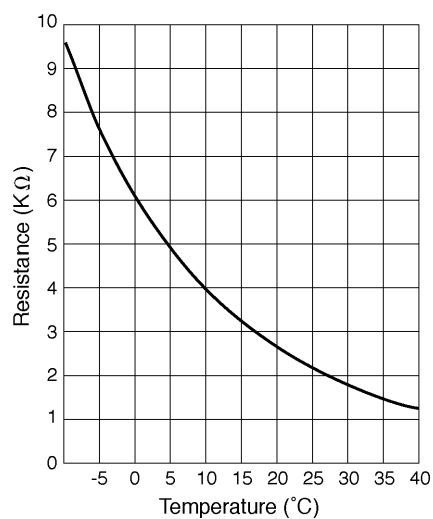

B4H1321B

AC-35

AUTOMATIC AIR CONDITIONING

HVAC System (Heater, Ventilator and A/C)

J: CONTROL SYSTEM

1. CALCULATION OF REQUIRED BLOW-OUT AIR TEMPERATURE (TAO)

1) REQUIRED BLOW-OUT AIR TEMPERATURE (TAO):

Upon reception of temperature set switch signals in addition to cabin temperature, ambient temperature and sunload sensor signals, the ECM calculates the TAO first and then, based on the calculated temperature, it determines the outlets from which the air is to be blown out.

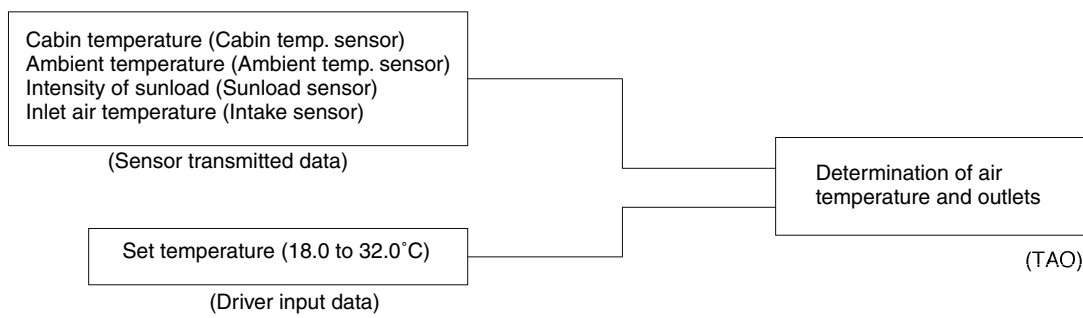

B4H1323B

2) CALCULATION OF REQUIRED TAO:

- When the set temperature is 18.0°C, the TAO is fixed at the MAX COOL.
- When the set temperature is 32.0°C, the TAO is fixed at the MAX HOT.
- When the set temperature is 18.5°C to 31.5°C, an optimum TAO is calculated based on the set temperature, as well as the cabin temperature, ambient temperature and sunload data at that time.

AUTOMATIC AIR CONDITIONING

HVAC System (Heater, Ventilator and A/C)

2. TEMPERATURE CONTROL

The temperature control is made based on the driver's inputs from the temperature set switch and the data from various temperature sensors; the ECM determines the TAO using these data and operates the air mix motor so that the TAO can be attained.

The ECM compares the air mix damper opening it has received from the air mix damper potentiometer with the target opening it has calculated and, if necessary, operates the motor to move the damper to the HOT or COLD side and hold the damper in an appropriate position.

The target damper opening is corrected using the sunlight intensity data.

The air mix damper is moved fully to the HOT side and held there when the temperature set switch is placed at the FULL HOT position (32°C), while it is moved fully to the COLD side and held there when the switch is placed at the FULL COLD position (18°C).

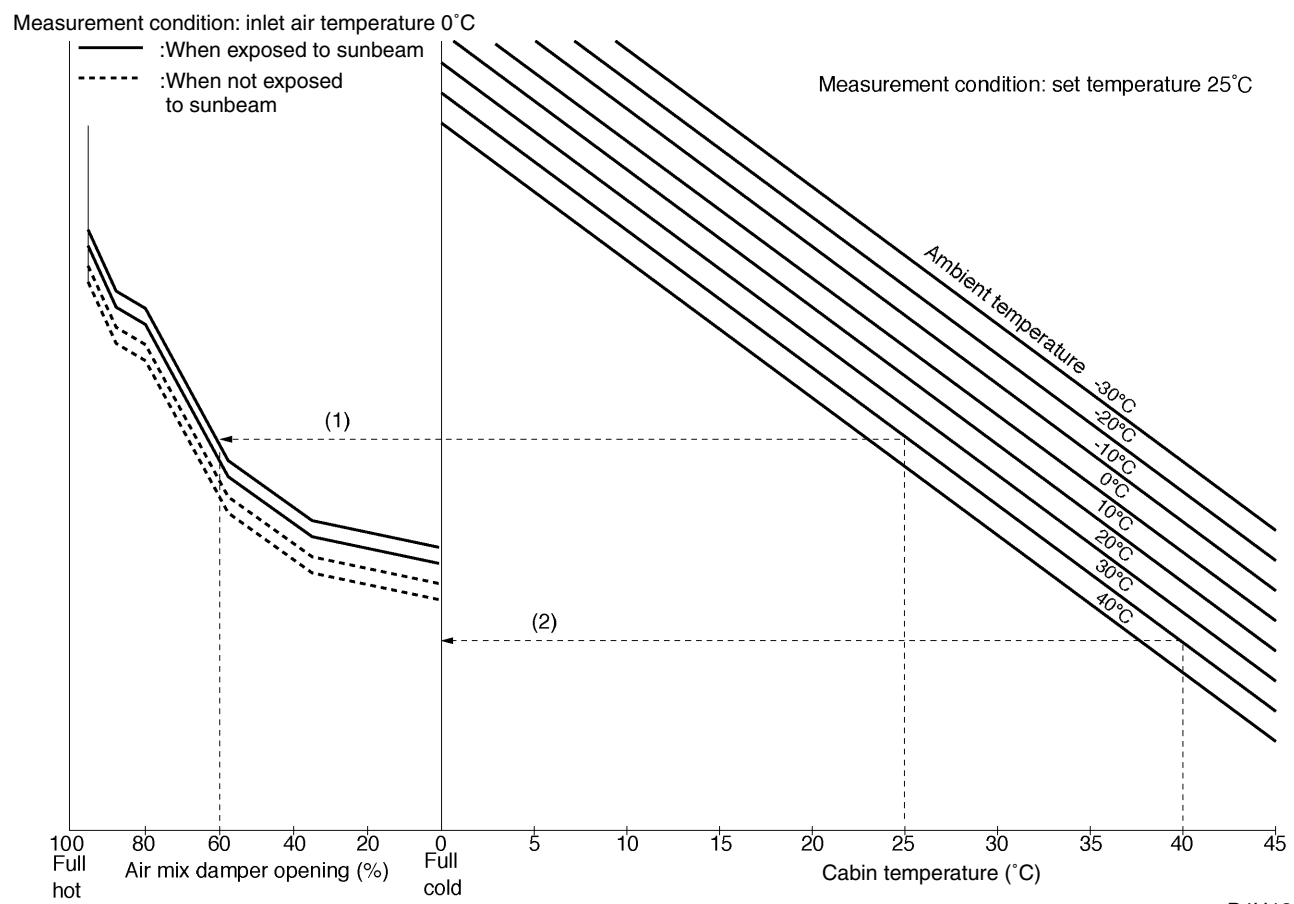

- (1) If the vehicle is exposed to sunbeam, the air mix damper opening is set to 60% when the cabin temperature is 25°C and the ambient temperature is 30°C.
- (2) The air mix damper opening is set to 0% (maximum cool position) when the cabin temperature is 40°C and ambient temperature is 30°C.

AUTOMATIC AIR CONDITIONING

HVAC System (Heater, Ventilator and A/C)

3. AIR FLOW CONTROL

- Normal air flow control:

When the air conditioning system is in the automatic control mode, the air flow is determined based on the TAO calculated by the ECM. The blower fan speed is controlled accordingly.

In the automatic control mode, the minimum air flow is different between DEF mode and the other modes. For the minimum air flow in BI-LEVEL, HEAT and DEF/HEAT modes, a voltage of 5.5V is applied to the blower motor, while for the DEF mode a voltage of 9.0V is applied.

The minimum air flow is corrected by the sunbeam intensity if the VENT or BI-LEVEL mode is selected.

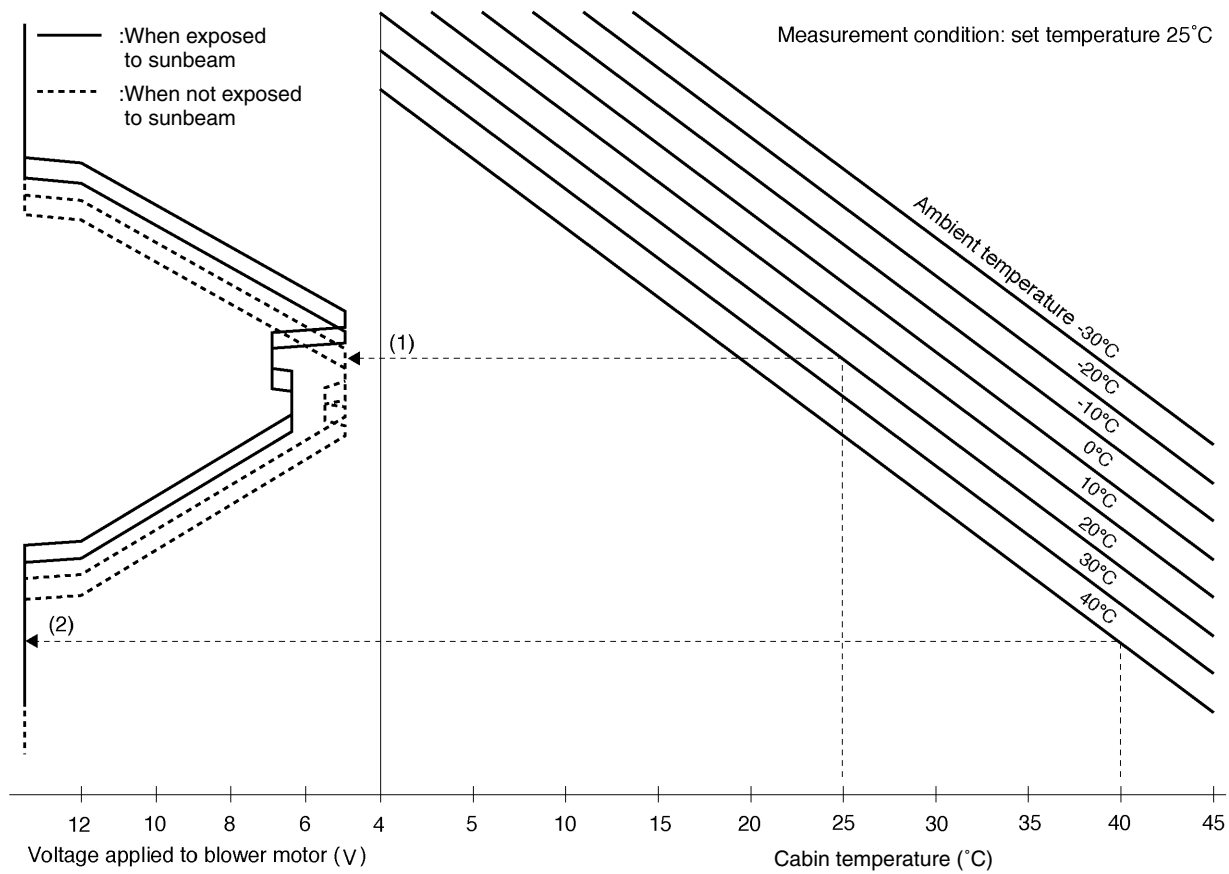

B4H1326B

- (1) If the vehicle is not exposed to sunbeam, a voltage of approx. 5V is applied to the blower motor when the cabin temperature is 25°C and the ambient temperature is 40°C.
- (2) The system (battery) voltage is applied to the blower motor when the cabin temperature is 40°C and the ambient temperature is 40°C.

AUTOMATIC AIR CONDITIONING

HVAC System (Heater, Ventilator and A/C)

- Blower fan starting speed control:

When the blower motor is turned ON in the automatic control mode, the fan speed is initially low and then gradually increases (applied voltage increases by 1V every second until an appropriate voltage is reached) to prevent air from blowing out in a gust.

- Blower fan control at low coolant temperatures:

Even when the blower motor is automatically turned ON, the blower fan is kept stopped or allowed to rotate at the minimum speed for a maximum of 150 seconds depending on the cabin temperature and the ambient temperature, if the engine coolant temperature is below 49°C with the air outlets for the VENT or DEF mode selected.

After the conditions for prohibiting blower fan operation or limiting its speed are removed, the voltage applied to the blower motor is increased gradually (by 0.34V every minute) such that a large amount of cold air does not blow out toward the leg area.

Once the coolant temperature exceeds 49°C, the normal blower fan control is performed including the starting speed control.

- Blower fan stop control with compressor ON:

The blower fan is stopped for 3 seconds if the compressor is turned ON with the intake sensor-detected temperature is higher than 35°C.

AUTOMATIC AIR CONDITIONING

HVAC System (Heater, Ventilator and A/C)

4. AIR INLET CONTROL SYSTEM

The air inlet control system determines whether the air inlet damper is to be opened depending on the TAO calculated by the ECM, thus selecting either inside air recirculation or fresh air introduction.

The damper is generally opened for fresh air introduction when the compressor is turned OFF. It is also opened generally when the DEF position is selected.

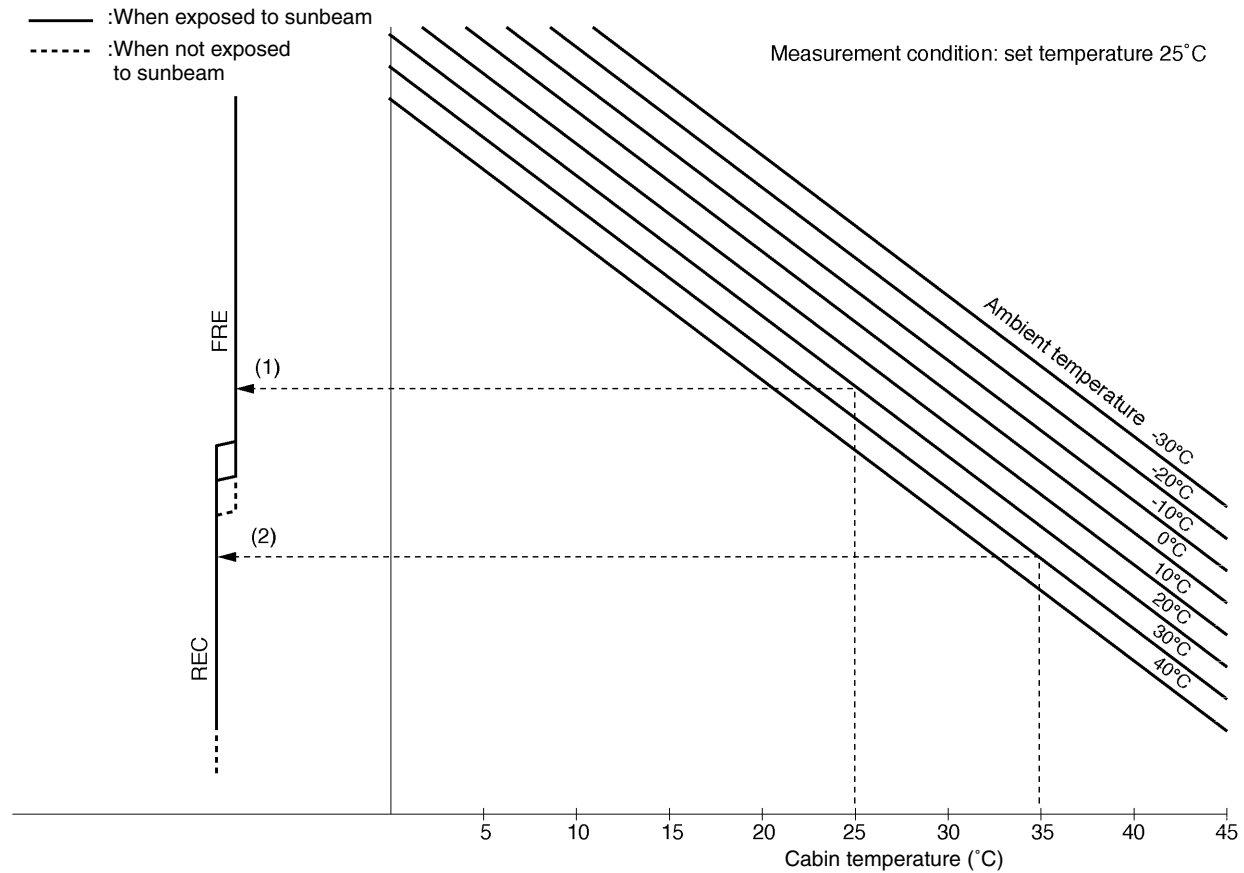

- (1) The air inlet damper is opened for fresh air introduction when the cabin temperature is 25°C and the ambient temperature is 20°C.
- (2) The air inlet damper is closed for inside air recirculation when the cabin temperature is 35°C and the ambient temperature is 30°C.

AC-40

AUTOMATIC AIR CONDITIONING

HVAC System (Heater, Ventilator and A/C)

5. AIR OUTLET CONTROL SYSTEM

The air outlet control system automatically selects the most appropriate air outlet combination depending on the ECM-calculated TAO by activating servo-motors for the VENT, BI-LEVEL or HEAT modes.

When the OFF switch is pressed position, the air outlet control system is held in the HEAT mode.

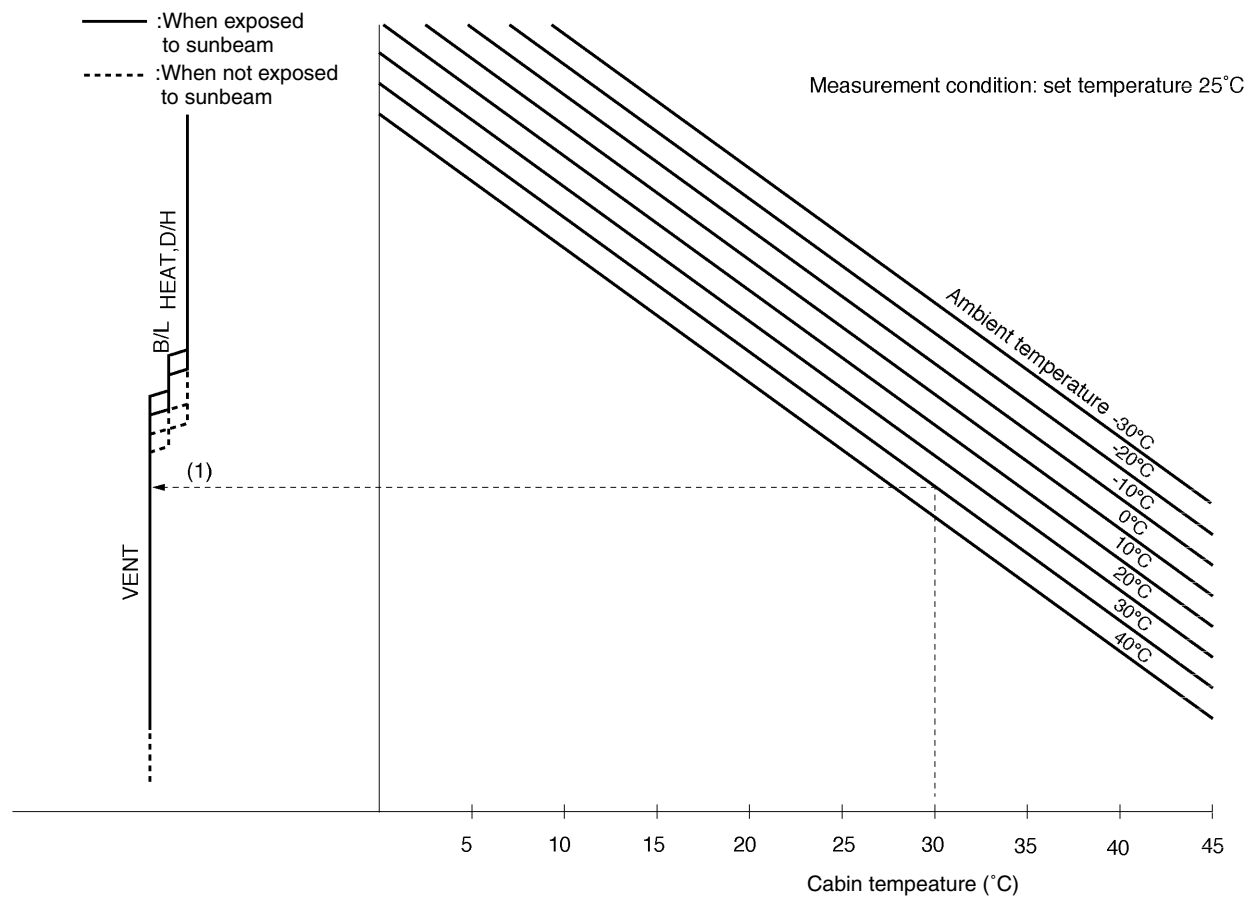

B4H1334B

(1) The air outlets for the VENT mode are selected when the cabin temperature is 30°C and the ambient temperature is 30°C.

AC-41

AUTOMATIC AIR CONDITIONING

HVAC System (Heater, Ventilator and A/C)

6. COMPRESSOR CONTROL SYSTEM

In the automatic air-conditioning mode, the A/C relay is activated or deactivated depending on the TAO (required blow-out air temperature), TAM (ambient temperature) and T INT (suction air temperature) to operate or stop the compressor.

The compressor operation circuit supplies current to the magnet clutch as the ECM activates the A/C relay by connecting its coil to the ground.

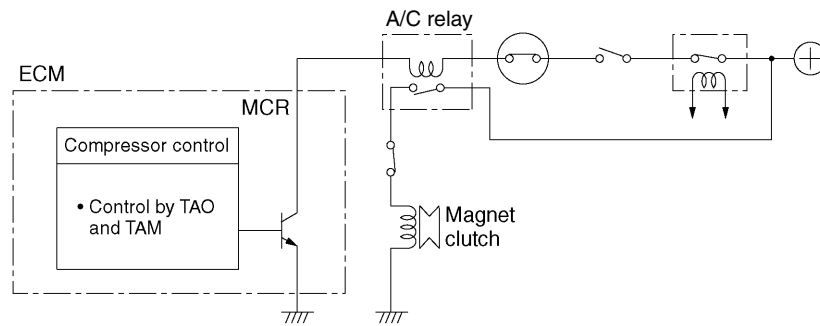

B4H1338C

- Control by TAO and TAM

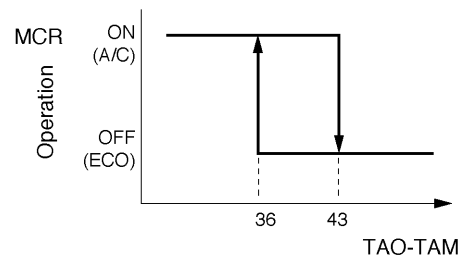

B4H1340A

- Control by T INT

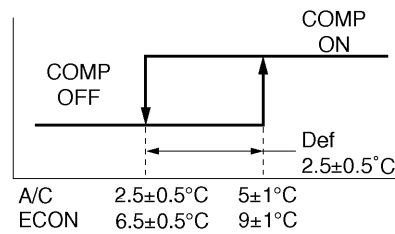

B4H1341B

AC-42