

GENERAL

Lubrication

1. General

- The lubrication system force-circulates engine oil throughout the engine using an oil pump. The oil pressure is regulated by the relief valve.
- The oil pump is a thin, large-diameter trochoid rotor type which can accommodate the engine's high output. The pump is directly driven by the crankshaft.
- The engine oil is cleaned by a full-flow, paper element type oil filter. The filter has a bypass valve which allows the engine oil to flow bypassing the filter if it is clogged.
- The engine oil discharged from the oil pump is delivered to the journal bearings, connecting rod bearings, and other parts requiring lubrication and cooling via an oil passage, oil filter, and oil galleries.
- The engine oil is also distributed to each cylinder head valve mechanism at a proper flow rate achieved by metering by the orifice provided in each cylinder head oil gallery.

LU-2

GENERAL

Lubrication

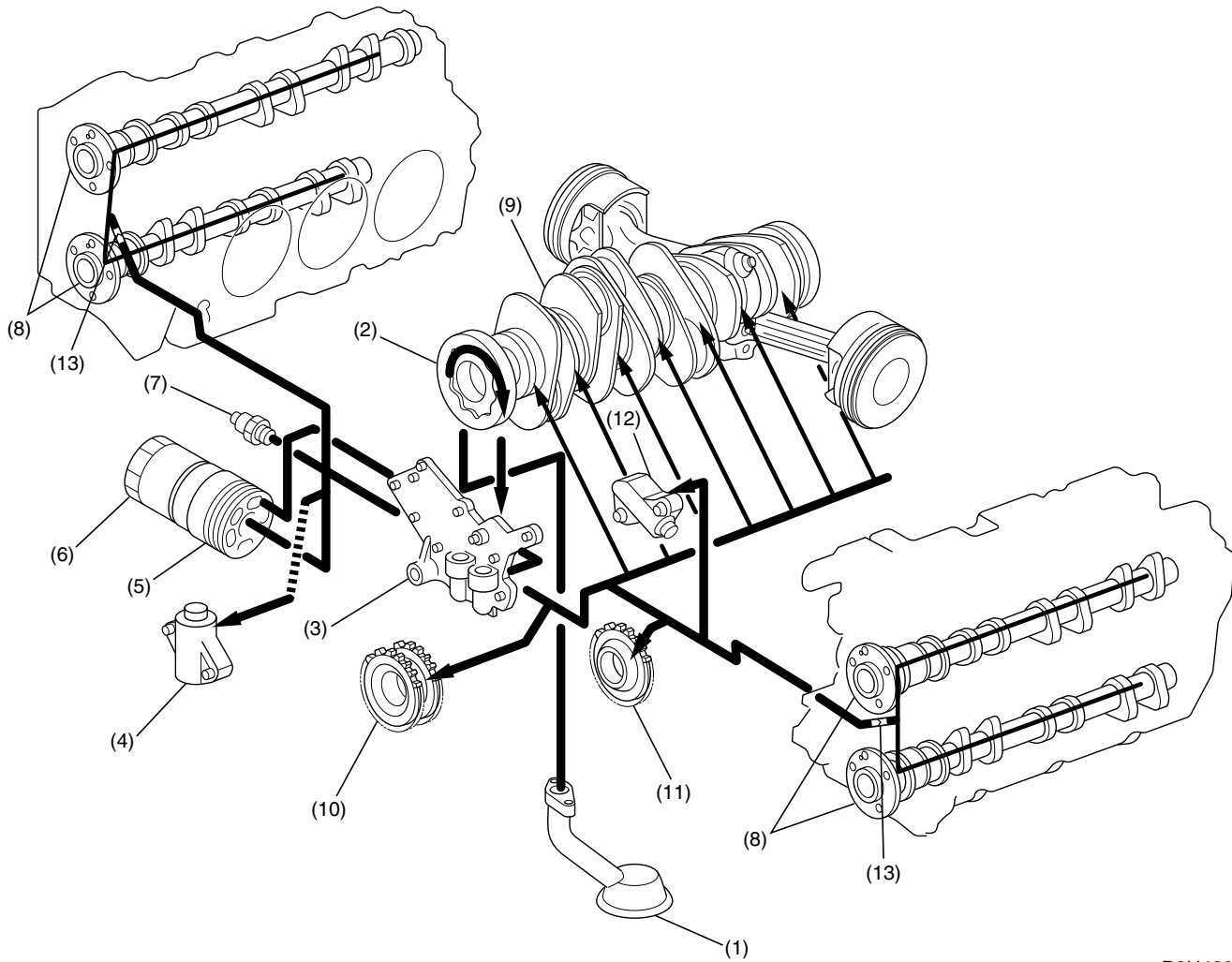

B2H4297A

- | | |
|-------------------------------|--------------------------------|
| (1) Oil strainer | (8) Camshaft |
| (2) Oil pump | (9) Crankshaft |
| (3) Relief valve case | (10) Lower idler sprocket |
| (4) Chain tension adjuster RH | (11) Upper idler sprocket |
| (5) Oil cooler | (12) Chain tension adjuster LH |
| (6) Oil filter | (13) Orifice |
| (7) Oil pressure switch | |

LU-3