

OIL PUMP AND RELIEF VALVE

Lubrication

3. Oil Pump and Relief Valve

- The oil pump is a thin, large-diameter trochoid roller pump directly driven by the crankshaft. Its outer rotor and inner rotor are assembled with each other inside the rotor housing which is formed in the rear chain cover. The rotor housing is closed by the oil pump cover. The outer rotor, inner rotor and the oil pump cover are made of sintered metal.
- When the pump discharge pressure exceeds a certain level, the relief valve located at the outlet port of the oil pump opens and allows excess oil to return to the inlet of the pump. The relief valve is a single-spool type and housed in an aluminum die-cast case. It is mounted on the rear chain cover with a metal gasket.

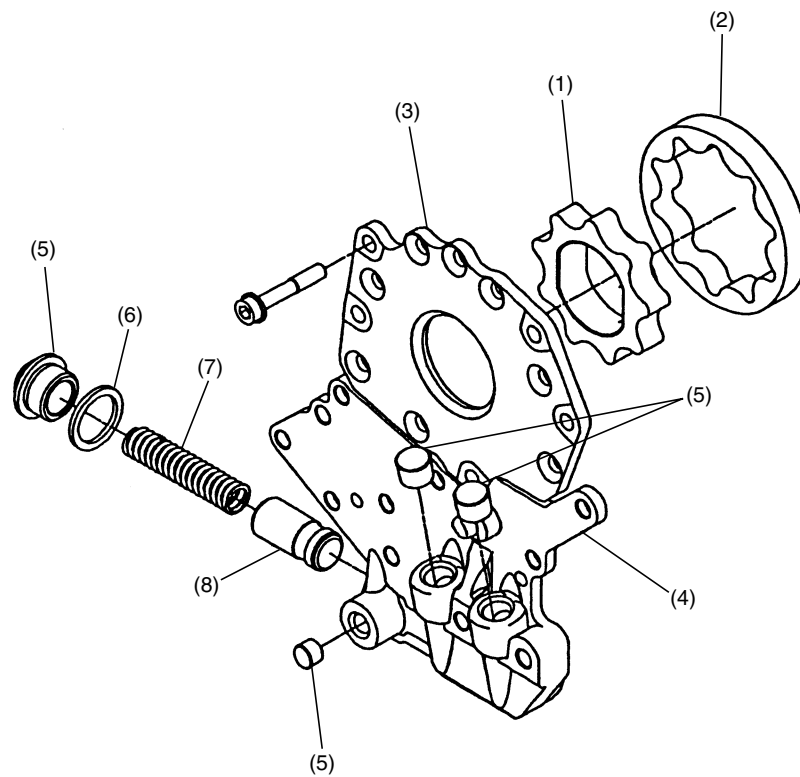

B2H3889A

- | | |
|-----------------------|-------------------------|
| (1) Inner rotor | (5) Plug |
| (2) Outer rotor | (6) Gasket |
| (3) Oil pump cover | (7) Relief valve spring |
| (4) Relief valve case | (8) Relief valve |

LU-5