

OIL PRESSURE SWITCH

Lubrication

6. Oil Pressure Switch

The oil pressure switch is located at the right of the upper oil pan. The purpose of this switch is to monitor the operation of the oil pump as well as the lubricating oil pressure when the engine is running.

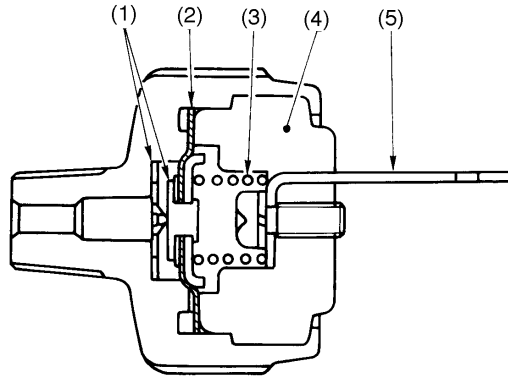

B2H1023

- | | |
|-------------------|--------------------|
| (1) Contact point | (4) Molded portion |
| (2) Diaphragm | (5) Terminal |
| (3) Spring | |

1) When oil pressure does not build up (immediately after ignition switch is turned ON):
The diaphragm is pushed toward the upper oil pan by the spring force (a force equivalent to the specified oil pressure). This closes the contact points, causing the oil pressure warning light in the combination meter to illuminate.

2) When oil pressure reaches the specified value (after engine starts):
After reaching the specified value of 14.7 kPa (0.15 kgf/cm², 2.1 psi), the oil pressure pushes the diaphragm overcoming the spring force. This opens the contact points and the oil pressure warning light goes out.

LU-8