

REVERSE CHECK MECHANISM

Manual Transmission and Differential

2. Reverse Check Mechanism

Located in the transfer case, the reverse check mechanism prevents a direct 5th-to-reverse shift by using a selector arm and cam combination which allows the gear to be shifted into the reverse only after it has been returned once into the neutral.

A: CONSTRUCTION

The construction of the reverse check mechanism is as shown in the drawing on the opposing page.

The reverse check sleeve is bolted to the transfer case and houses the mechanism's main components.

The reverse accent shaft is slidable inside the reverse check sleeve and its smaller-diameter end is fitted with the reverse check cam. The cam is rotatable and axially movable on the shaft but its leftward movement is restricted by a step formed on the sleeve's inner wall.

The reverse accent shaft has hollows in both ends. In the left end hollow are the 1st return spring and its cap and in the right end hollow is the reverse return spring which pushes the shaft leftward.

Around the check cam is the reverse check spring whose left end applies simultaneous leftward and rotational forces to the cam.

Both the reverse check spring and reverse return spring are retained at their right ends by the reverse check plate which is held in place by the snap ring.

The reverse accent shaft has a V-groove in which the detent ball is pressed by the reverse accent spring fitted through the hole in the reverse check sleeve.

The reverse check sleeve and reverse accent shaft have a slot and a notch at their bottoms, respectively, and the selector arm is inserted in the notch through the slot.

MT-4

REVERSE CHECK MECHANISM

Manual Transmission and Differential

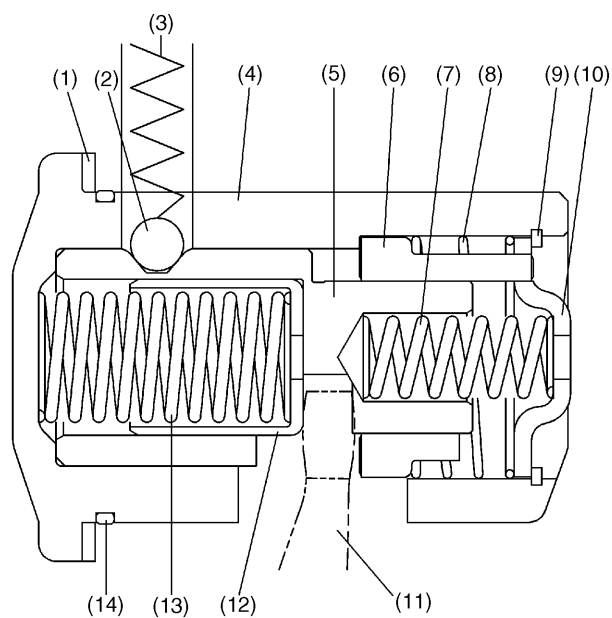

B3H1007A

- | | | |
|---------------------------|---------------------------|------------------------|
| (1) Select adjust shim | (6) Reverse check cam | (11) Selector arm |
| (2) Detent ball | (7) Reverse return spring | (12) Spring cap |
| (3) Reverse accent spring | (8) Reverse check spring | (13) 1st return spring |
| (4) Reverse check sleeve | (9) Snap ring | (14) O-ring |
| (5) Reverse accent shaft | (10) Reverse check plate | |

MT-5

REVERSE CHECK MECHANISM

Manual Transmission and Differential

B: OPERATION

The drawing below shows the state of the reverse check mechanism when the selector arm is in the neutral position. The 1st and 2nd gears will be selected if the selector arm is moved leftward from this point to a stop and then turned in either way. A rightward movement of the arm to a stop will enable selection of the 5th and reverse gears. In the neutral position, the selector arm receives a rightward force (force toward the 5th and reverse gear side) from the 1st return spring and a leftward force (force toward the 1st and 2nd gear side) from the reverse return spring to stay in that position.

The following explanation describes how the selector arm and reverse check mechanism operate when the driver selects the 5th gear and then selects the reverse gear.

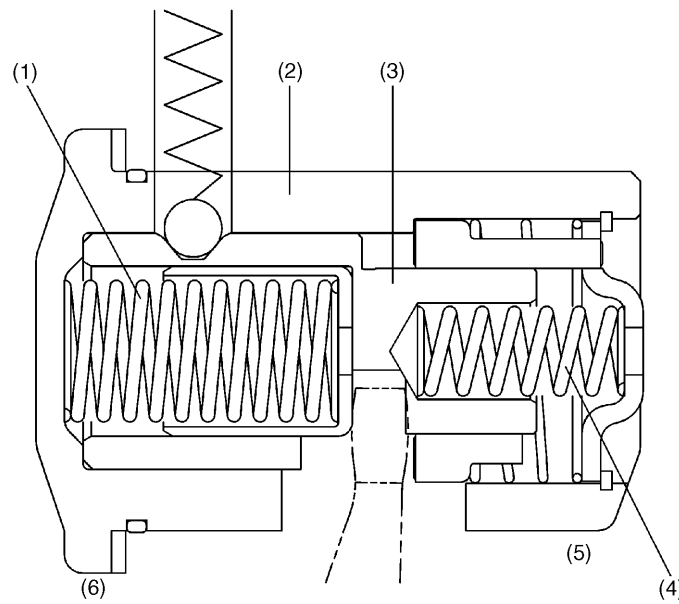

B3H1007B

- | | | |
|--------------------------|---------------------------|-------------------------------|
| (1) 1st return spring | (3) Reverse accent shaft | (5) 5th and reverse gear side |
| (2) Reverse check sleeve | (4) Reverse return spring | (6) 1st and 2nd gear side |

MT-6

REVERSE CHECK MECHANISM

Manual Transmission and Differential

1. WHEN SELECTOR ARM IS MOVED TOWARD 5TH AND REVERSE GEAR SIDE

The selector arm moves rightward while pushing both the reverse accent shaft and reverse check cam simultaneously.

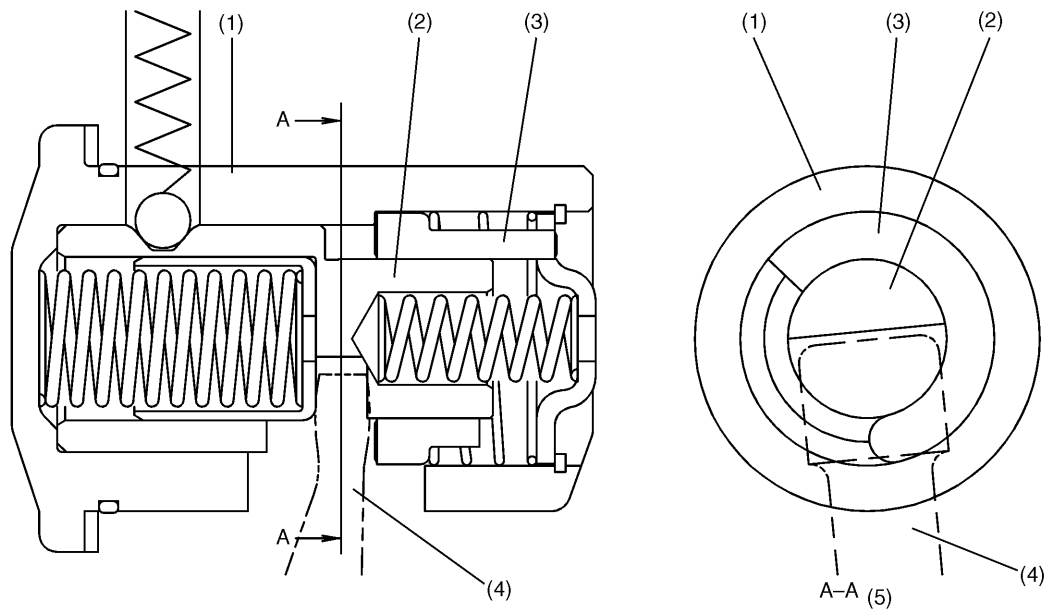

B3H1008B

- | | |
|--------------------------|-----------------------|
| (1) Reverse check sleeve | (3) Reverse check cam |
| (2) Reverse accent shaft | (4) Selector arm |

- (5) Neutral position

2. WHEN SHIFT IS MADE TO 5TH GEAR

The selector arm is turned toward the 5th gear selection direction. When the arm clears the edge of the reverse check cam as it turns, the cam becomes free of the selector arm's pressure and returns to its original position by the force of the reverse check spring.

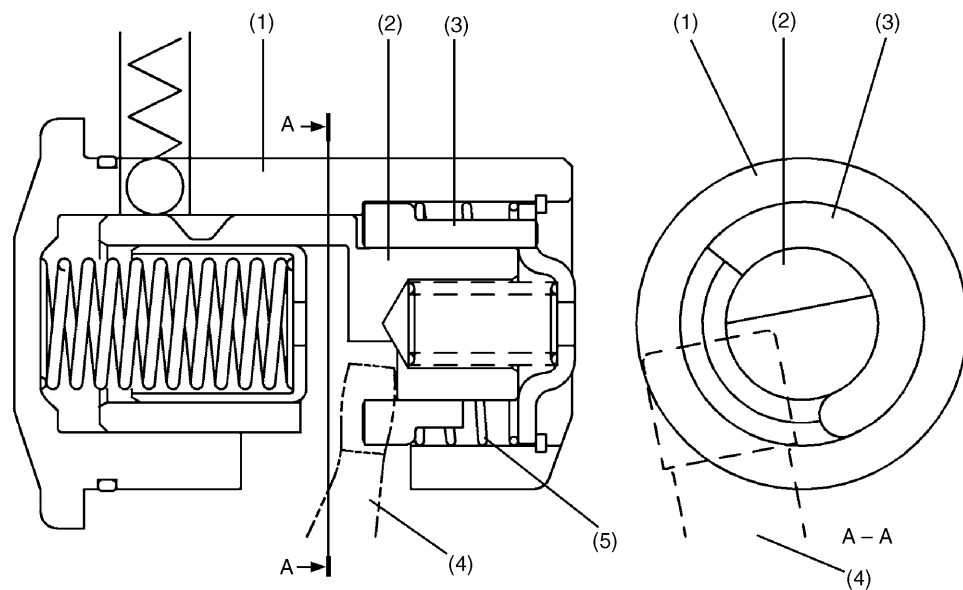

B3H1009A

- | | |
|--------------------------|-----------------------|
| (1) Reverse check sleeve | (3) Reverse check cam |
| (2) Reverse accent shaft | (4) Selector arm |

- (5) Reverse check spring

MT-7

REVERSE CHECK MECHANISM

Manual Transmission and Differential

3. WHEN A SHIFT FROM 5TH TO REVERSE IS ATTEMPTED

The selector arm turns toward the reverse gear while pushing the reverse accent shaft rightward and the reverse check cam counterclockwise (as viewed in the direction of arrows A).

The reverse check cam, however, stops to rotate at a point where its stopper hits against the reverse check plate (this point corresponds to the neutral position in terms of the angle) and prevents the selector arm from moving toward the reverse gear selection direction. The selector arm is then axially pushed to the neutral position by the reverse accent shaft which is given a leftward force by the reverse return spring.

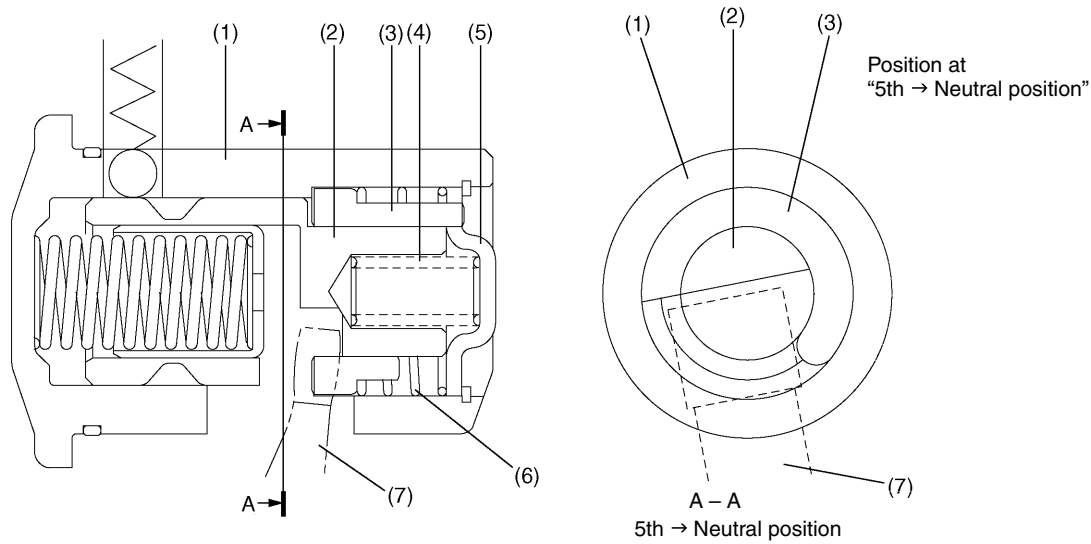

B3H2118A

- (1) Reverse check sleeve
- (2) Reverse accent shaft
- (3) Reverse check cam
- (4) Reverse return spring

- (5) Reverse check plate
- (6) Snap ring
- (7) Selector arm

MT-8

REVERSE CHECK MECHANISM

Manual Transmission and Differential

4. WHEN A SHIFT TO REVERSE IS MADE AFTER RETURN OF SELECTOR ARM TO NEUTRAL

As the ends of the reverse accent shaft and the reverse check cam are on the same plane, the selector arm now can turn toward the reverse gear selection direction after pushing leftward both the shaft and cam simultaneously.

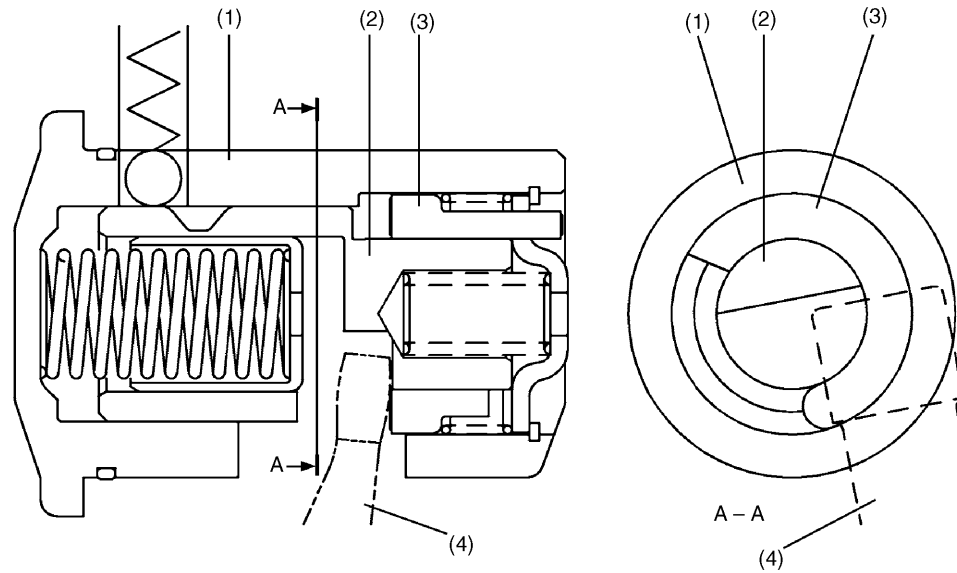

- (1) Reverse check sleeve
- (2) Reverse accent shaft

- (3) Reverse check cam
- (4) Selector arm

B3H1011A

MT-9