

## CYLINDER HEAD

Mechanical

### 6. Cylinder Head

- The cylinder heads are made of aluminum alloy which features light weight and high cooling efficiency.
- Each cylinder head incorporates a DOHC mechanism which is adapted to the “four valves per cylinder” arrangement. The two intake ports are designed to create tumble flow in the cylinder, whereas the two exhaust ports join each other in the cylinder head to form a single oval port. These design features contribute together to cleaner exhaust emissions and higher output.
- The combustion chamber is of a compact pentroof design with the spark plug located at its top center. In combination with the tumble promoting intake ports, a squish area formed between the piston top surface and combustion chamber helps improve mixing of air and fuel and thus combustion efficiency.
- Coolant flows from the rear to the front of the cylinder head of each bank. This serial-flow coolant line arrangement ensures highly efficient cooling of the engine.
- A metal gasket is used between the cylinder head and cylinder block. Tightening the cylinder head bolts by the angle-tightening method ensures invariable sealing performance of this gasket.

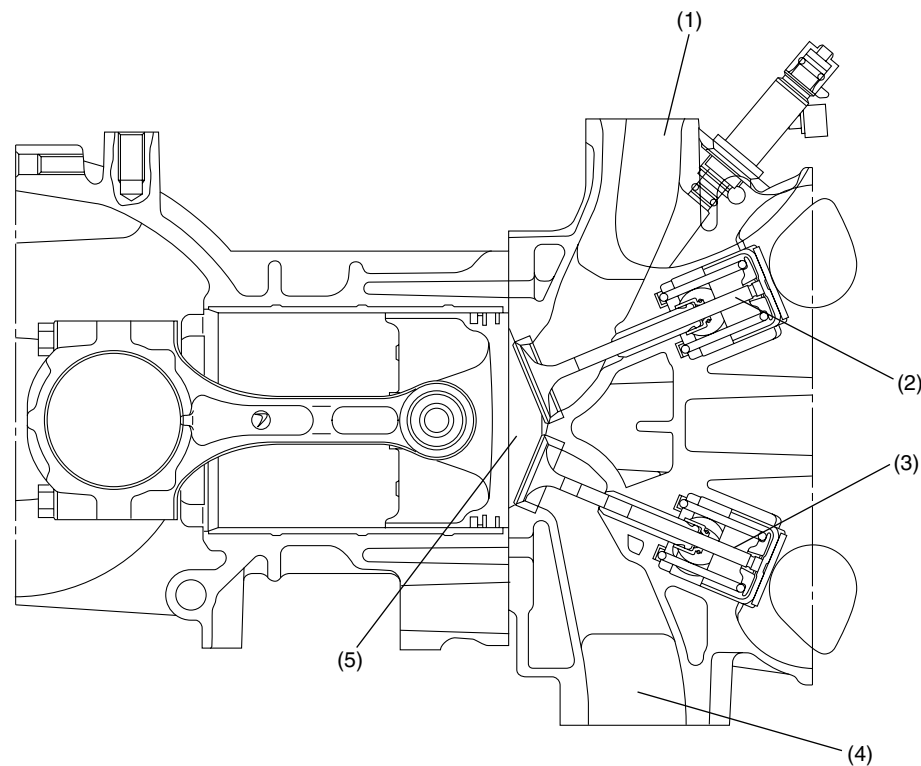

B2H4295A

- (1) Intake port
- (2) Intake valve
- (3) Exhaust valve

- (4) Exhaust port
- (5) Combustion chamber

**ME-7**