

BELT COVER

Mechanical

4. Belt Cover

- The belt cover is made of lightweight, heat resistant synthetic resin molding. It constitutes a totally enclosed housing with its cylinder block mating edges sealed with rubber gaskets. This effectively protects the inside components from dust and liquid.
- Rubber seals used between the cylinder block and the belt cover effectively reduces transmission of noise and vibration.
- The front belt cover has a line mark for ignition-timing checking.

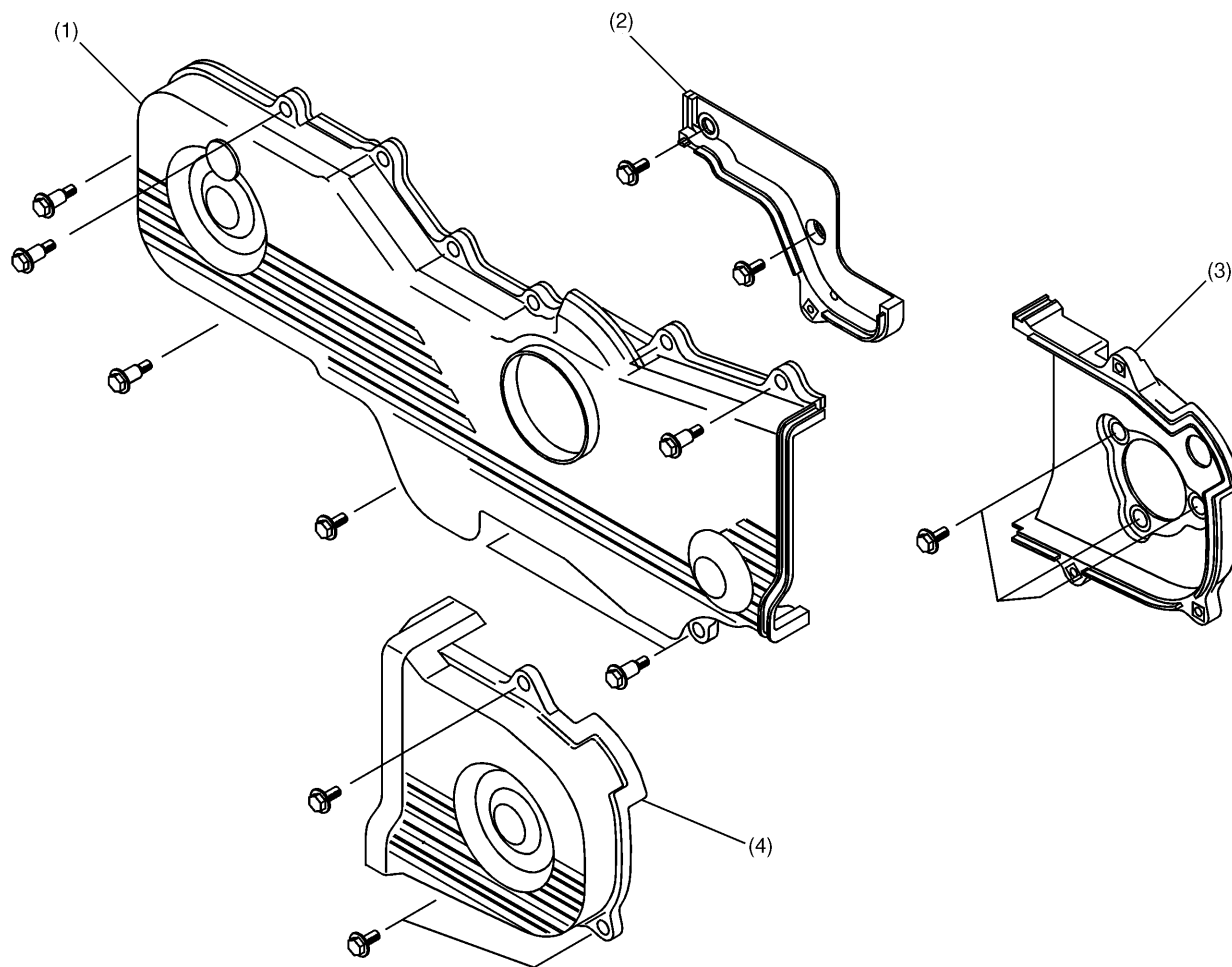

NF0042

- (1) Front belt cover
- (2) Belt cover No. 2 (RH)
- (3) Belt cover No. 2 (LH)
- (4) Belt cover (LH)

ME-6