

## CYLINDER HEAD

Mechanical

### 7. Cylinder Head

- The cylinder head is made of aluminium die casting.
- Each combustion chamber in the cylinder head is a compact, pentroof design. The spark plug is located at the center of the combustion chamber, which contributes to creation of a wide “squish area” for increased combustion efficiency.
- The two intake and two exhaust valves are arranged on opposite sides for a cross-flow feature.
- The cylinder head gasket is a metallic gasket consisting of three layers of the stainless steel sheets. It is highly resistant to heat and maintains high level of sealing performance for a long period.

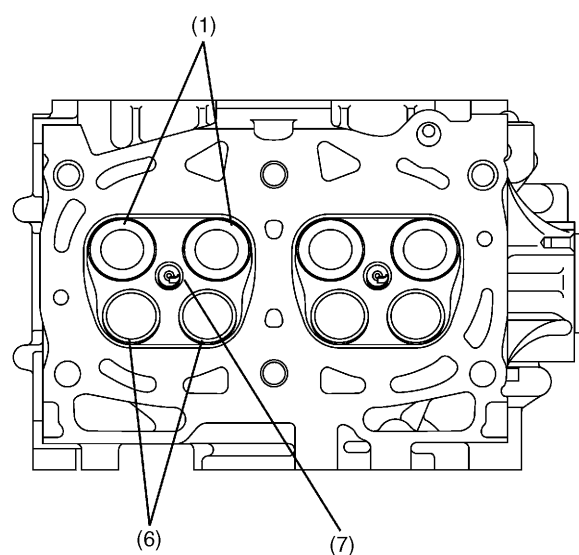
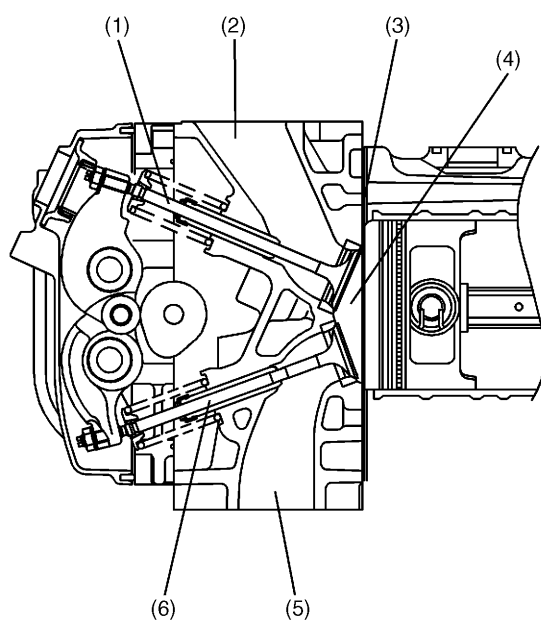

NF0045

- (1) Intake valve
- (2) Intake port
- (3) Squish area
- (4) Combustion chamber

- (5) Exhaust port
- (6) Exhaust valve
- (7) Spark plug

ME-9