

PARKING BRAKE

Parking Brake

1. Parking Brake

The parking brake uses a drum housed in the disc rotor of each rear disc brake. The shoes are mechanically controlled through linkage and cables.

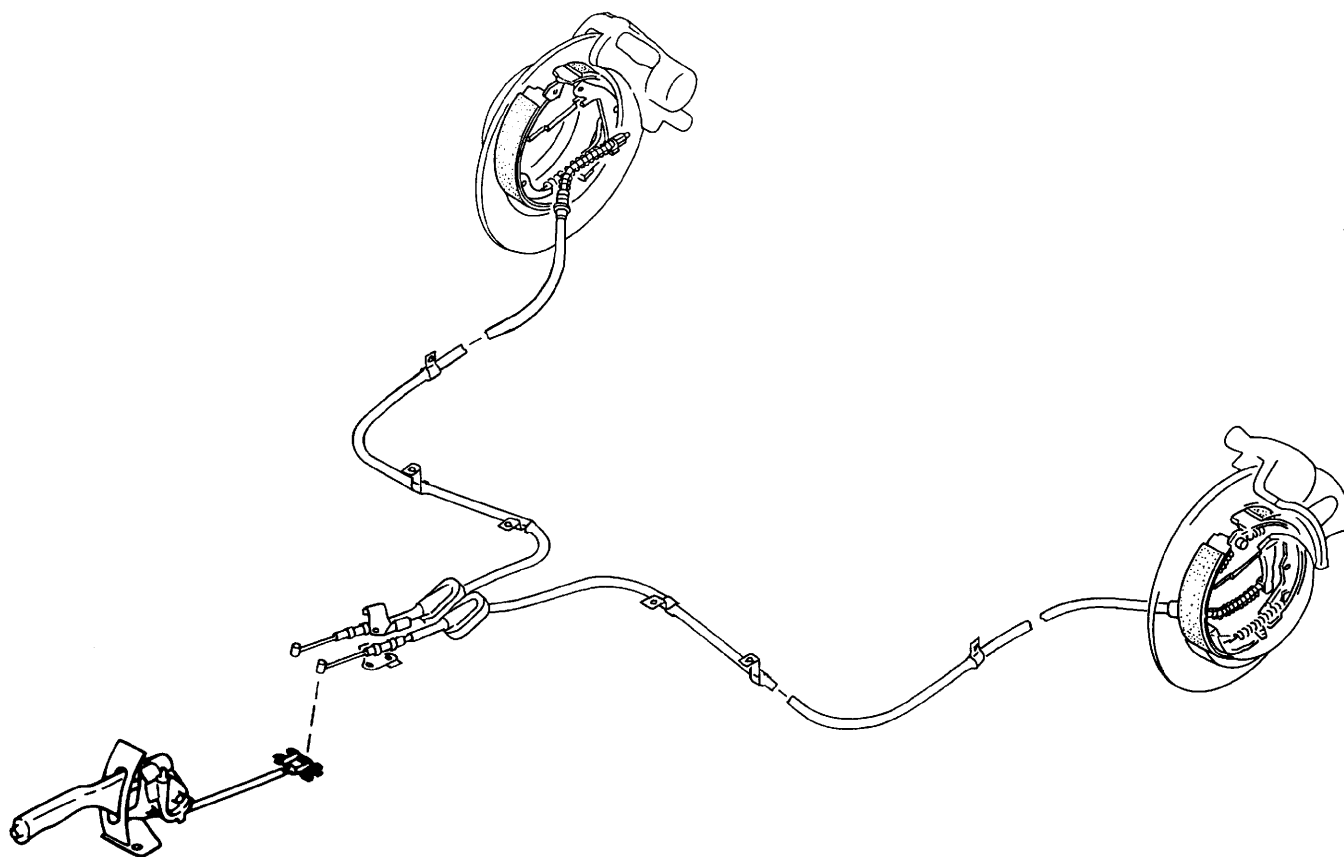

B4H1939

PB-2

PARKING BRAKE

Parking Brake

A: OPERATION

1. SETTING

When the parking brake lever is pulled, the shoe actuating lever to which the end of the parking brake cable is connected turns the strut in direction "F" around point "P".

The strut then presses the brake shoes A and B against the drum. These brake shoes utilize a floating design and are movably supported by hold-down pins. The force applied to brake shoe A and the reaction force "F" applied to the brake shoe B via point "P" press them against the brake drum.

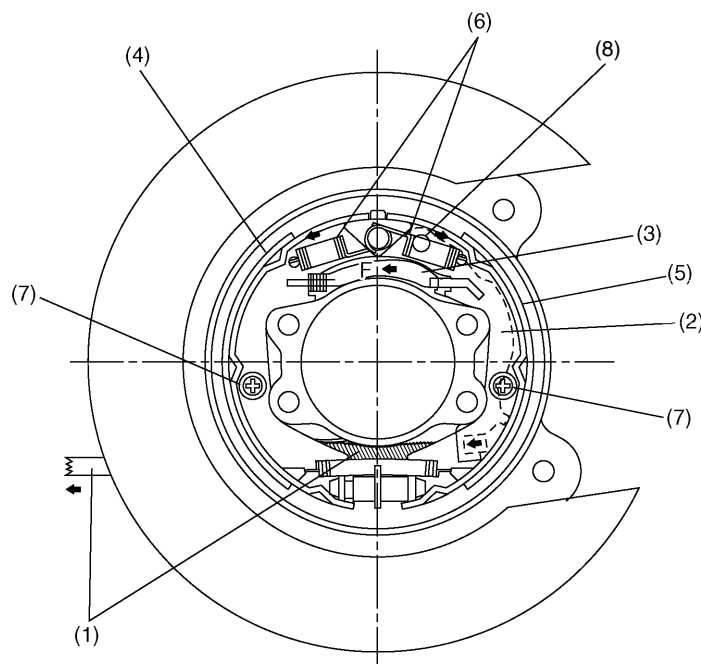

B4H1940B

- | | |
|-------------------------|------------------------|
| (1) Parking brake cable | (5) Brake shoe B |
| (2) Lever | (6) Shoe return spring |
| (3) Strut | (7) Shoe hold down pin |
| (4) Brake shoe A | (8) Point "P" |

PB-3

PARKING BRAKE

Parking Brake

2. RELEASING

When the parking brake lever is returned to the release position and the parking brake cables are slackened, the brake shoes A and B are moved back to their original positions by the tension of return springs, so that the parking brake is released.

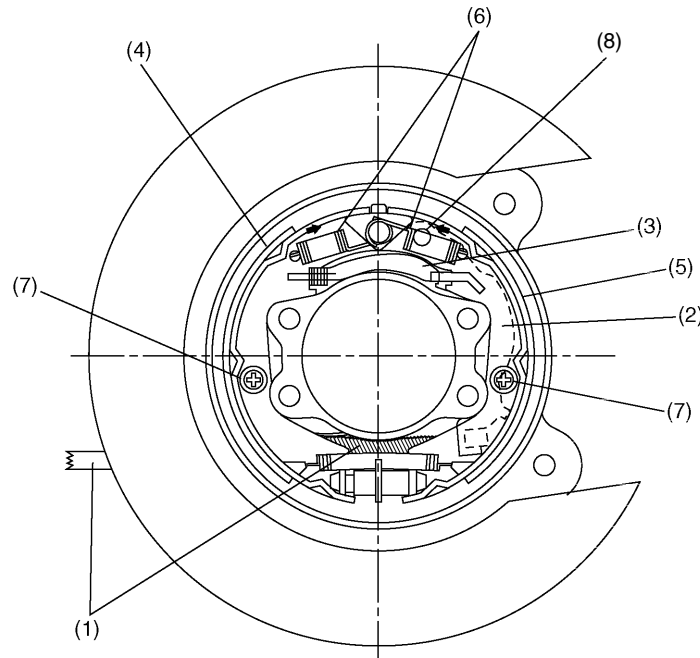

B4H1941B

- (1) Parking brake cable
- (2) Lever
- (3) Strut
- (4) Brake shoe A

- (5) Brake shoe B
- (6) Shoe return spring
- (7) Shoe hold down pin
- (8) Point "P"

PB-4