

VEHICLE DYNAMICS CONTROL (VDC) SYSTEM

VDC

1. Vehicle Dynamics Control (VDC) System

A: OUTLINE

The vehicle dynamics control (VDC) system is a driver assist system which enhances vehicle's running stability by utilizing the anti-lock brake system (ABS) and traction control system (TCS) functions in combination with its own function which reduces sudden changes in vehicle behavior that are likely to occur when travelling on a slippery road or quickly avoiding an obstacle on the road.

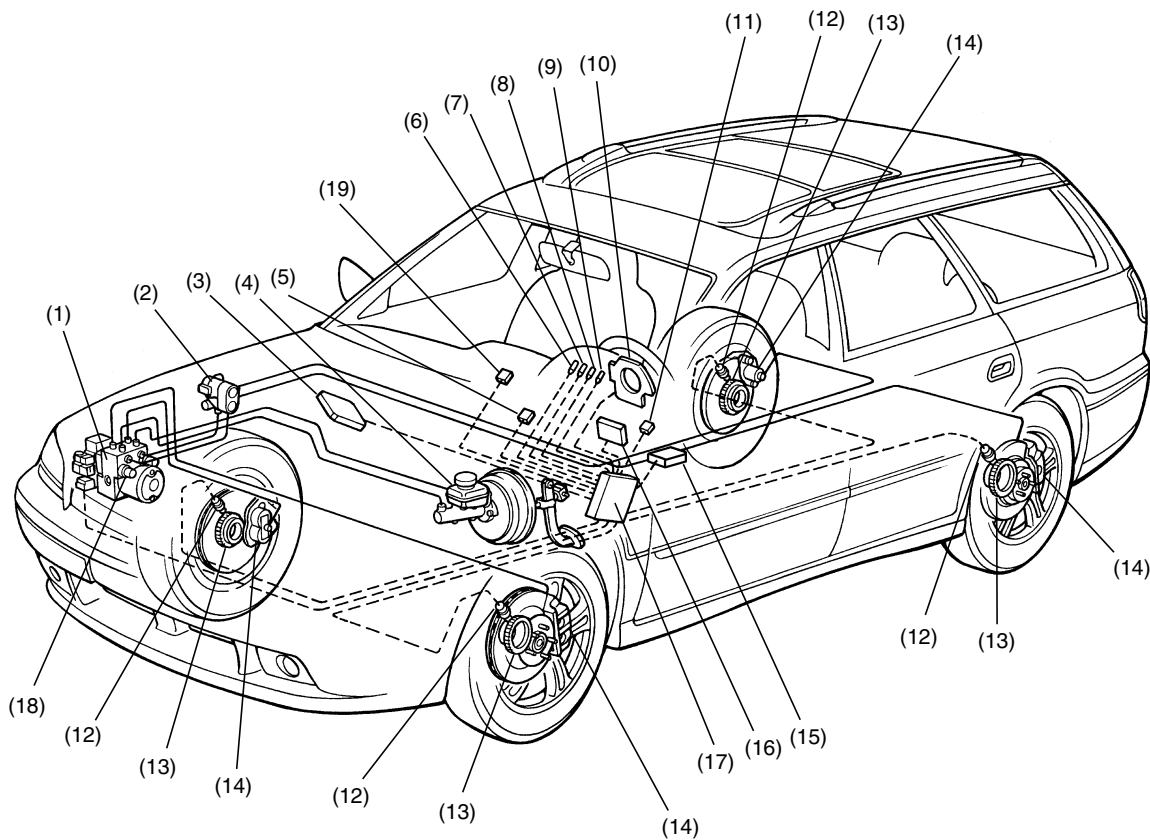

B4H0579A

- | | | |
|--------------------------------|--|--|
| (1) VDC hydraulic control unit | (8) VDC operating indicator light | (15) Yaw-rate and lateral G sensor |
| (2) Proportioning valve | (9) VDC OFF indicator light | (16) Automatic transmission control module |
| (3) Engine control module | (10) Steering angle sensor | (17) VDC control module |
| (4) Master cylinder | (11) Data link connector (for SUBARU select monitor) | (18) Pressure sensor |
| (5) Diagnosis connector | (12) ABS sensor | (19) VDC OFF switch |
| (6) ABS warning light | (13) Tone wheel | |
| (7) VDC warning light | (14) Wheel cylinder | |

VDC-2

VEHICLE DYNAMICS CONTROL (VDC) SYSTEM

VDC

B: OPERATION PRINCIPLE OF VDC

1. OVERSTEER SUPPRESSION

When the vehicle starts to spin during cornering, the VDC control module (VDCCM) actuates the brakes on the front and rear outer wheels. As a result, a force that counteracts the oversteer-causing yaw moment is generated so that the vehicle's behavior is stabilized.

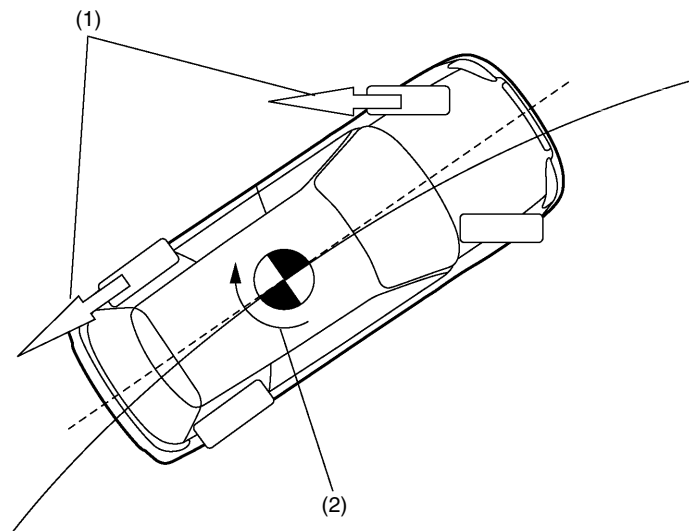

B4H1634B

- (1) Braking force
- (2) Oversteer-causing yaw moment

2. UNDERSTEER SUPPRESSION

When the vehicle starts to drift outward during cornering, the VDCCM causes the rear inner wheel to be braked. As a result, a force that counteracts the understeer-causing yaw moment is generated so that the vehicle's behavior is stabilized.

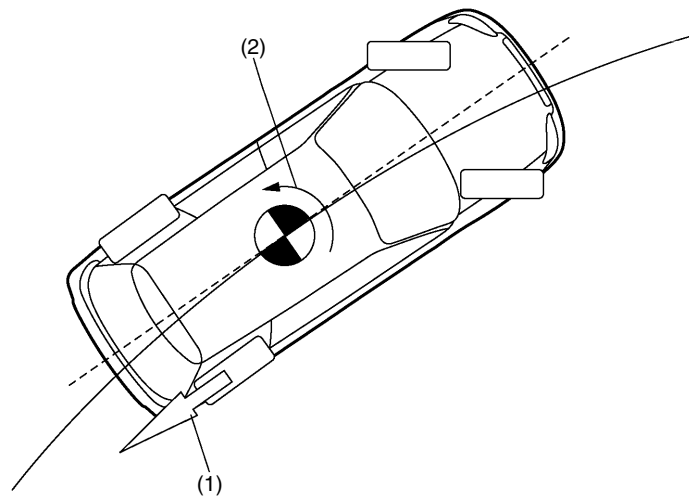

B4H1635B

- (1) Braking force
- (2) Understeer-causing yaw moment

VDC-3

VEHICLE DYNAMICS CONTROL (VDC) SYSTEM

VDC

C: FUNCTIONS USED IN VEHICLE'S BEHAVIOR STABILIZATION CONTROL

VDC function	The VDC control module (VDCCM) determines the driver's intention from the data provided by the steering angle sensor, braking pressure sensor, engine-related sensors and other relevant sources and recognizes the result as the target vehicle behavior. At the same time, it determines the vehicle's actual behavior from the data provided by the yaw-rate sensor, lateral G sensor, ABS sensor and other relevant sources. Then, the module compares the target and actual vehicle behaviors to estimate how the vehicle is running (whether it understeers, oversteers, slips or is in other condition), and based on the result, performs braking control of individual wheels, engine output control and AWD control as necessary to correct the vehicle's running condition.
TCS function	The TCS constantly receives signals from the relevant sensors to monitor the vehicle speed. When the running wheels slip exceeding a certain limit, it performs braking control of individual wheels, engine output control and AWD control as required to maintain optimal traction and adequate side force.
ABS function	The ABS constantly receives signals from the relevant sensors to monitor the vehicle speed. When the slip of wheels during braking exceeds a certain limit, it performs braking control of individual wheels and AWD control as required to maintain optimal traction and adequate side force.

NOTE:

- "Braking control" is effected by the VDCCM as follows:

The VDCCM calculates the required braking force for each wheel and sends signals to the VDC hydraulic unit. The hydraulic unit's motor pump is then operated to generate the required hydraulic pressure. Further, it controls the hydraulic unit's solenoid valves to increase, maintain or decrease the hydraulic pressure applied to the brake wheel cylinder as required.

When the brakes are applied by the driver, however, the braking force is controlled by the hydraulic pressure resulting from the driver's action.

- "Engine output control" is effected by the VDCCM as follows:

The VDCCM calculates the target engine output for each condition, and compares it with the current engine output. Based on the result of comparison, it determines the number of cylinders for which fuel injection is to be stopped and sends a command to the engine control module. The targeted engine output is then achieved.

- "AWD control" is effected by the VDCCM as follows:

When necessary, the VDCCM sends a command to the automatic transmission control module. According to the command, the transmission control module controls the transfer clutch so that the torque is distributed between the front and rear axles optimally.

VEHICLE DYNAMICS CONTROL (VDC) SYSTEM

VDC

D: SYSTEM COMPONENTS AND FUNCTIONS

VDCCM	<ul style="list-style-type: none"> • Determines the vehicle's running condition from various sensor signals and, based on the result, controls the VDC hydraulic control unit, ABS and TCS as required. • Performs CAN communication with the automatic transmission control module and the steering angle sensor. • Causes the system to stop and the warning light to illuminate if a fault occurs in a circuit of the electrical system. Stores the code that indicates the location of the fault.
VDC Hydraulic Control Unit (VDCH/U)	Actuates the pump motor in response to a command from the VDCCM and changes fluid passages using solenoid valves to control the hydraulic pressures applied to the wheel cylinders.
Steering angle sensor	Detects the steering direction and angle when the steering wheel is operated by the driver and outputs signals corresponding to them to the VDCCM.
Yaw-rate and lateral G sensor	Detects the yaw-rate and lateral G of the vehicle and outputs it to the VDCCM.
Pressure sensor	Detects the hydraulic pressure resulting from driver's brake pedal operation and outputs it to the VDCCM.
ABS sensor (wheel speed sensor)	Detects the speed of each wheel and outputs it to the VDCCM.
Tone wheel	Causes changes in magnetic flux density as its teeth move to enable the ABS sensor to detect the wheel speed.
Engine Control Module (ECM)	Controls the engine output in response to commands from the VDCCM. Further, it transmits current engine output and engine speed signals to the VDCCM.
Automatic transmission control module	Controls the transfer clutch in response to commands from the VDCCM during VDC control, ABS control or TCS control so that torque is distributed optimally between the front and rear axles.
ABS warning light	Alerts the driver to an ABS fault.
VDC warning light	Alerts the driver to a VDC or TCS fault.
VDC operating indicator light	Blinks when the VDC is operating or lights steadily when the TCS is operating.
VDC OFF indicator light	Illuminates to tell the driver that the VDC and TCS are inactive (not due to a system failure).
VDC OFF switch	<ul style="list-style-type: none"> • Allows the driver to temporarily disengage VDC control. • In "temporarily disengaged" status, the VDC OFF indicator light illuminates.

NOTE:

CAN (Controller Area Network) communication refers to bidirectional multiplex high-speed communication.

VEHICLE DYNAMICS CONTROL (VDC) SYSTEM

VDC

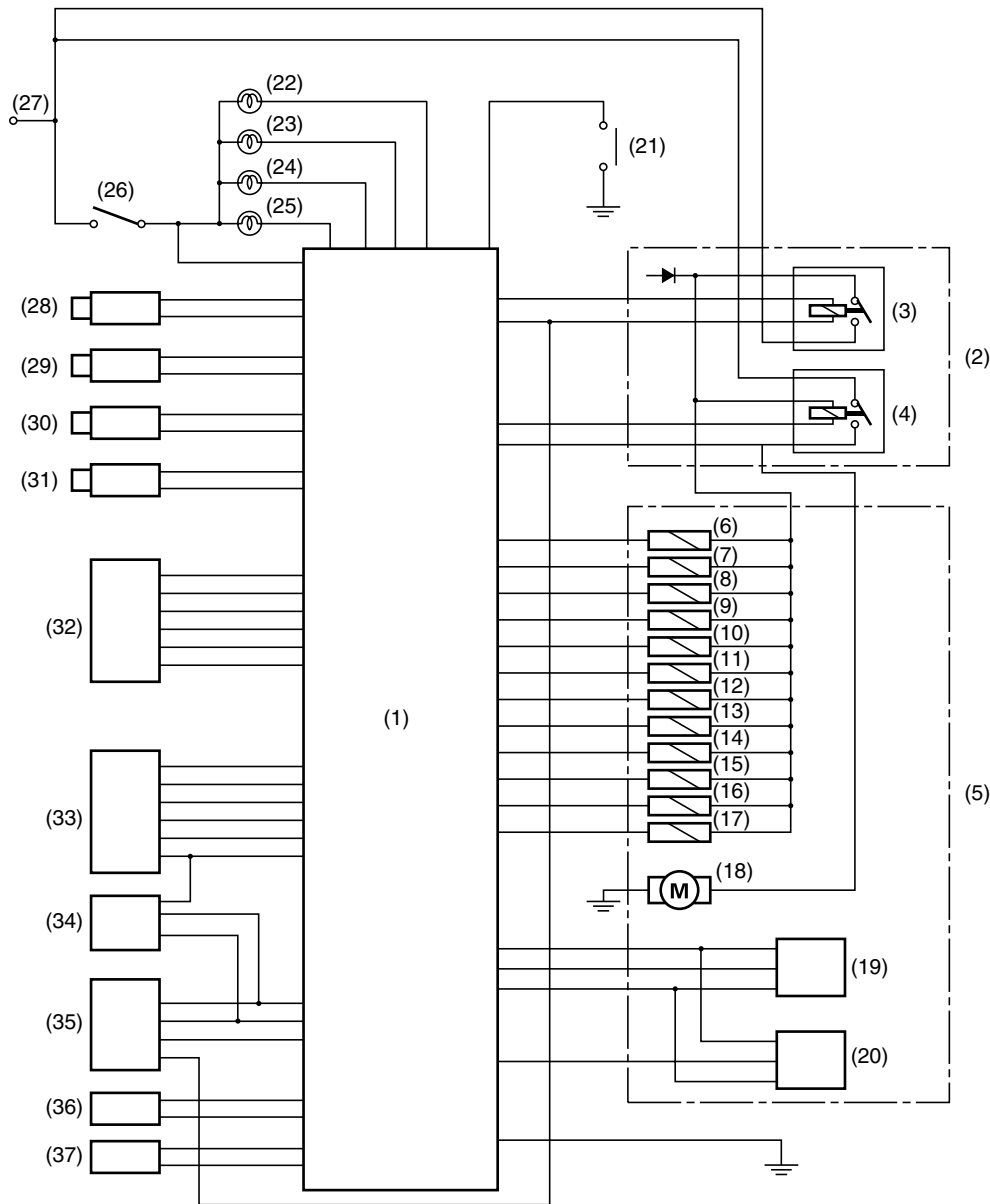

B4H2542A

- | | | |
|---------------------------------------|---------------------------------------|--|
| (1) VDC control module | (14) Primary suction solenoid valve | (27) BATTERY |
| (2) Relay box | (15) Primary cut solenoid valve | (28) Front left ABS sensor |
| (3) Valve relay | (16) Secondary suction solenoid valve | (29) Front right ABS sensor |
| (4) Motor relay | (17) Secondary cut solenoid valve | (30) Rear left ABS sensor |
| (5) Hydraulic control unit | (18) Pump motor | (31) Rear right ABS sensor |
| (6) Front left inlet solenoid valve | (19) Primary pressure sensor | (32) Yaw-rate and lateral G sensor |
| (7) Front left outlet solenoid valve | (20) Secondary pressure sensor | (33) Engine control module |
| (8) Front right inlet solenoid valve | (21) VDC OFF switch | (34) Automatic transmission control module |
| (9) Front right outlet solenoid valve | (22) ABS warning light | (35) Steering angle sensor |
| (10) Rear left inlet solenoid valve | (23) VDC warning light | (36) Diagnosis connector |
| (11) Rear left outlet solenoid valve | (24) VDC operating indicator light | (37) Data link connector |
| (12) Rear right inlet solenoid valve | (25) VDC OFF indicator light | |
| (13) Rear right outlet solenoid valve | (26) Ignition relay | |

VDC-6

VEHICLE DYNAMICS CONTROL (VDC) SYSTEM

VDC

E: VDC OFF SWITCH

A switch which allows the driver to temporarily disengage VDC control is added.

In some occasions, better results are obtained by cancelling the VDC to allow the drive wheels to slip for a certain amount:

- When starting the vehicle on icy or unpaved, steep uphill roads.
- When escaping from mud or snow when the wheels are caught in them.
- When the VDC OFF switch is pressed while the engine is running, the VDC OFF indicator light in the combination meter illuminates, and VDC control is temporarily disengaged. When the VDC OFF switch is pressed again, the VDC OFF indicator light turns off and the system returns to “engaged” status. (“Temporarily disengaged” status and “engaged” status are altered each time the switch is pressed.)
- The VDC control “temporarily disengaged” status automatically returns to “engaged” status when the vehicle speed exceeds 60 km/h (38 MPH). (VDC control cannot be temporarily disengaged at vehicle speeds higher than 60 km/h (38 MPH).)
- If the VDC OFF switch is pressed and held for more than 10 seconds, the VDC OFF indicator light in the combination meter turns off. The system will not allow further operation of the switch until the engine is started for the next time.

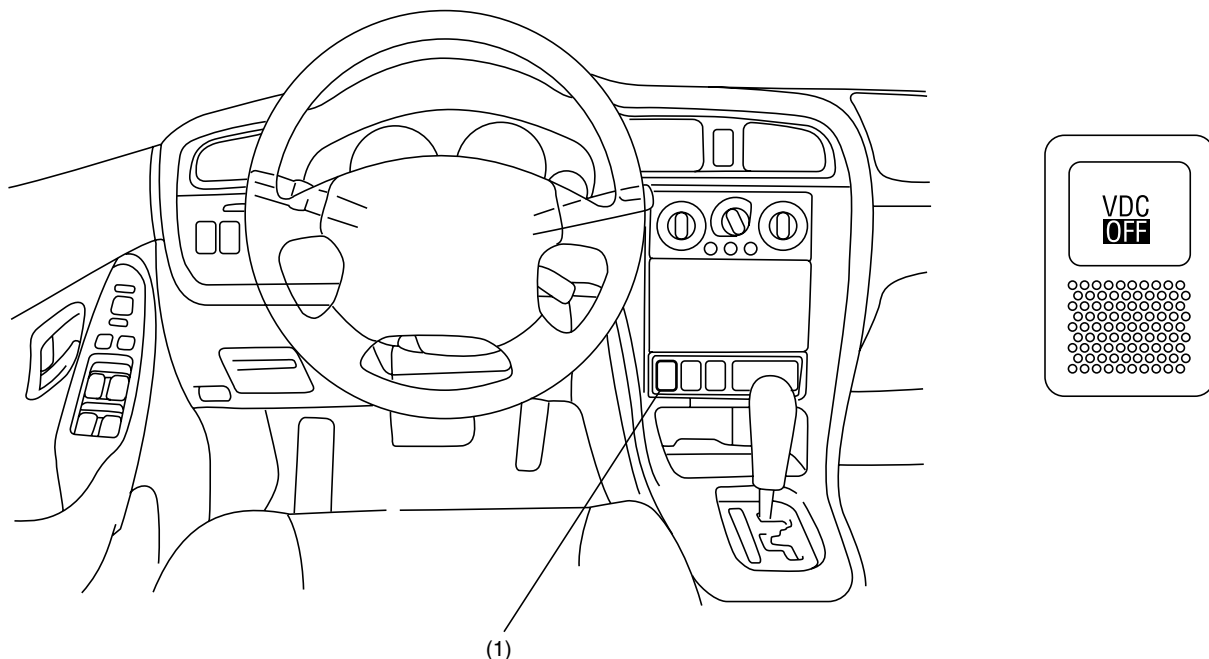

(1) VDC OFF switch

B4H2543A

VDC-7

VEHICLE DYNAMICS CONTROL (VDC) SYSTEM

VDC

F: OPERATION OF VDC HYDRAULIC CONTROL UNIT (VDCH/U)

1. DURING NORMAL BRAKING

No solenoid valves are energized. The ports of the inlet solenoid valve and cut solenoid valve are open, while the ports of the outlet solenoid valve and suction solenoid valve are closed.

In this state, the fluid pressure generated by the master cylinder can be applied to the wheel cylinder through the open ports of the cut solenoid valve and inlet solenoid valve.

NOTE:

For simplicity of explanation, operation of the hydraulic control unit is represented by operation of a single wheel circuit.

VDC-8

VEHICLE DYNAMICS CONTROL (VDC) SYSTEM

VDC

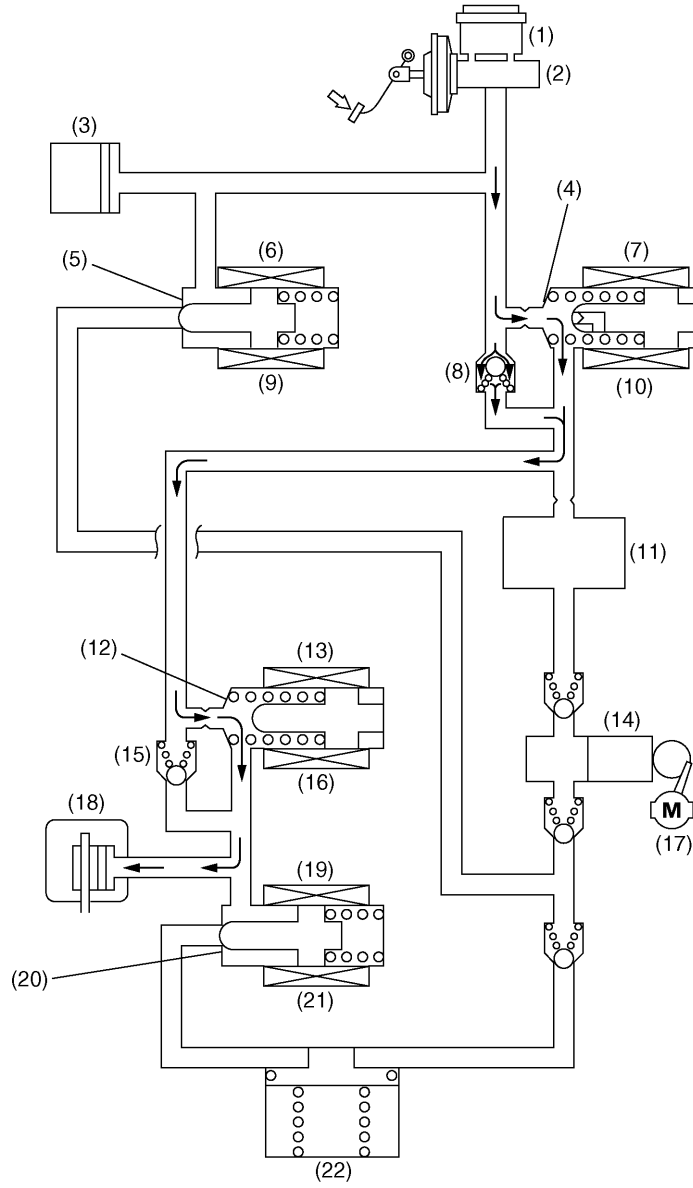

B4H1637B

- | | | |
|----------------------------|---------------------------|----------------------------|
| (1) Reservoir tank | (9) De-energized | (17) Motor |
| (2) Master cylinder | (10) De-energized | (18) Wheel cylinder |
| (3) Pressure sensor | (11) Damper chamber | (19) Outlet solenoid valve |
| (4) Port open | (12) Port open | (20) Port closed |
| (5) Port closed | (13) Inlet solenoid valve | (21) De-energized |
| (6) Suction solenoid valve | (14) Pump | (22) Reservoir |
| (7) Cut solenoid valve | (15) Check valve | |
| (8) Check valve | (16) De-energized | |

VDC-9

VEHICLE DYNAMICS CONTROL (VDC) SYSTEM

VDC

2. PRESSURE “DECREASE” CONTROL WITH BRAKE PEDAL DEPRESSED

The inlet solenoid valve and outlet solenoid valve are energized, while the other solenoid valves are not energized. This means that the ports of the inlet solenoid valve and suction solenoid valve are closed, while those of the outlet solenoid valve and cut solenoid valve are open.

Although the fluid pressure generated by the master cylinder can reach the inlet solenoid valve through the open port of the cut solenoid valve, the pressurized fluid cannot go further since the passage is blocked there. On the other hand, since the port of the outlet solenoid valve is open, the brake fluid in the wheel cylinder can flow out into the reservoir. The fluid pressure in the wheel cylinder decreases as a result. The brake fluid in the reservoir is pumped back into the master cylinder.

NOTE:

For simplicity of explanation, operation of the hydraulic control unit is represented by operation of a single wheel circuit.

VDC-10

VEHICLE DYNAMICS CONTROL (VDC) SYSTEM

VDC

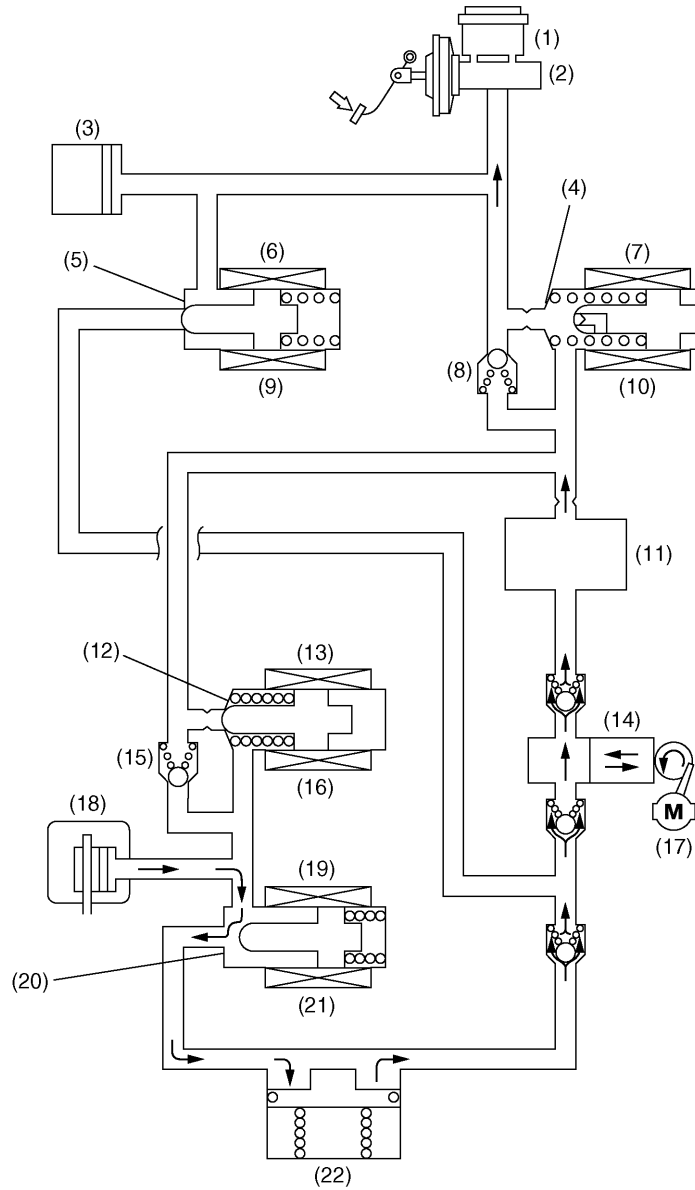

B4H1638B

- | | | |
|----------------------------|---------------------------|----------------------------|
| (1) Reservoir tank | (9) De-energized | (17) Motor |
| (2) Master cylinder | (10) De-energized | (18) Wheel cylinder |
| (3) Pressure sensor | (11) Damper chamber | (19) Outlet solenoid valve |
| (4) Port open | (12) Port closed | (20) Port open |
| (5) Port closed | (13) Inlet solenoid valve | (21) Energized |
| (6) Suction solenoid valve | (14) Pump | (22) Reservoir |
| (7) Cut solenoid valve | (15) Check valve | |
| (8) Check valve | (16) Energized | |

VDC-11

VEHICLE DYNAMICS CONTROL (VDC) SYSTEM

VDC

3. PRESSURE “HOLD” CONTROL WITH BRAKE PEDAL DEPRESSED

Only the inlet solenoid valve is energized. This means that the ports of the inlet solenoid valve, outlet solenoid valve and suction solenoid valve are all closed except that of the cut solenoid valve.

In this state, the fluid pressure generated by the master cylinder is transmitted through the open port of the cut solenoid valve to the inlet solenoid valve but not beyond the inlet solenoid valve since the passage is blocked there. As the port of the outlet solenoid valve is also closed, the fluid pressure in the wheel cylinder is held unreleased.

The pump is always operated whenever commanded by the VDCCM.

NOTE:

For simplicity of explanation, operation of the hydraulic control unit is represented by operation of a single wheel circuit.

VDC-12

VEHICLE DYNAMICS CONTROL (VDC) SYSTEM

VDC

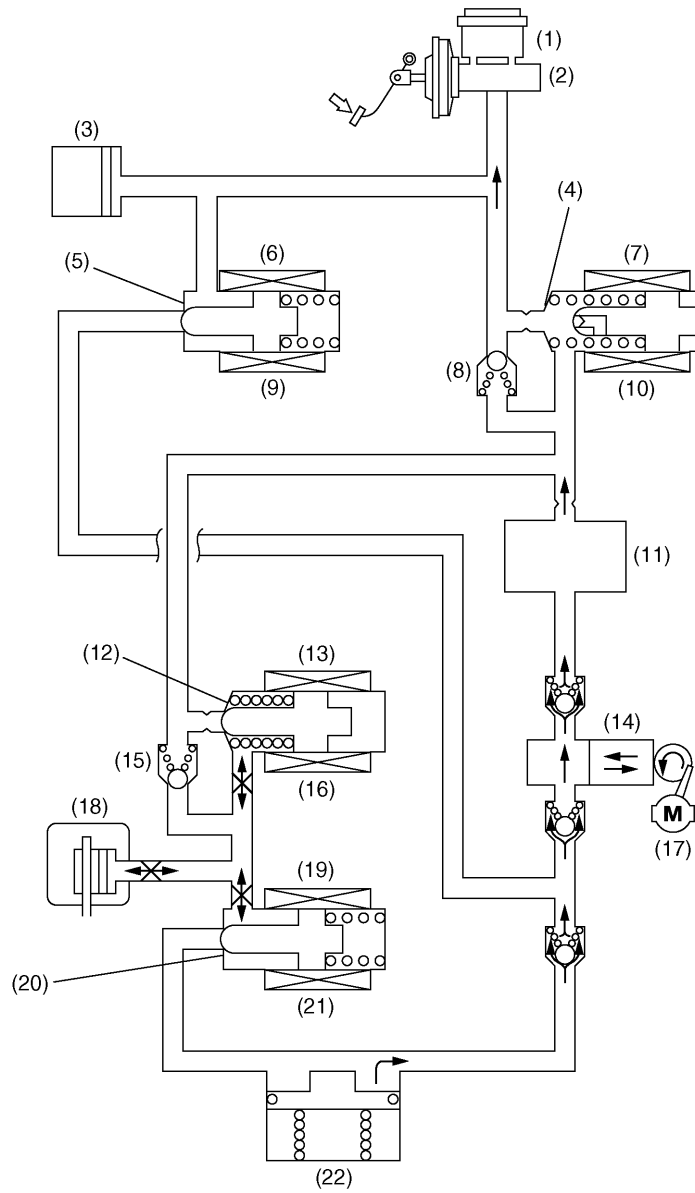

B4H1639B

- | | | |
|----------------------------|---------------------------|----------------------------|
| (1) Reservoir tank | (9) De-energized | (17) Motor |
| (2) Master cylinder | (10) De-energized | (18) Wheel cylinder |
| (3) Pressure sensor | (11) Damper chamber | (19) Outlet solenoid valve |
| (4) Port open | (12) Port closed | (20) Port closed |
| (5) Port closed | (13) Inlet solenoid valve | (21) De-energized |
| (6) Suction solenoid valve | (14) Pump | (22) Reservoir |
| (7) Cut solenoid valve | (15) Check valve | |
| (8) Check valve | (16) Energized | |

VDC-13

VEHICLE DYNAMICS CONTROL (VDC) SYSTEM

VDC

4. PRESSURE “INCREASE” CONTROL WITH BRAKE PEDAL DEPRESSED

No solenoid valves are energized. This means that the ports of the inlet solenoid valve and cut solenoid valve are open, while those of the outlet solenoid valve and suction solenoid valve are closed.

In this state, the fluid pressure generated by the master cylinder is transmitted to the wheel cylinder through the open ports of the cut solenoid valve and inlet solenoid valve, applying the brake with an increased force. The pump is always operated whenever commanded by the VDCCM.

NOTE:

For simplicity of explanation, operation of the hydraulic control unit is represented by operation of a single wheel circuit.

VDC-14

VEHICLE DYNAMICS CONTROL (VDC) SYSTEM

VDC

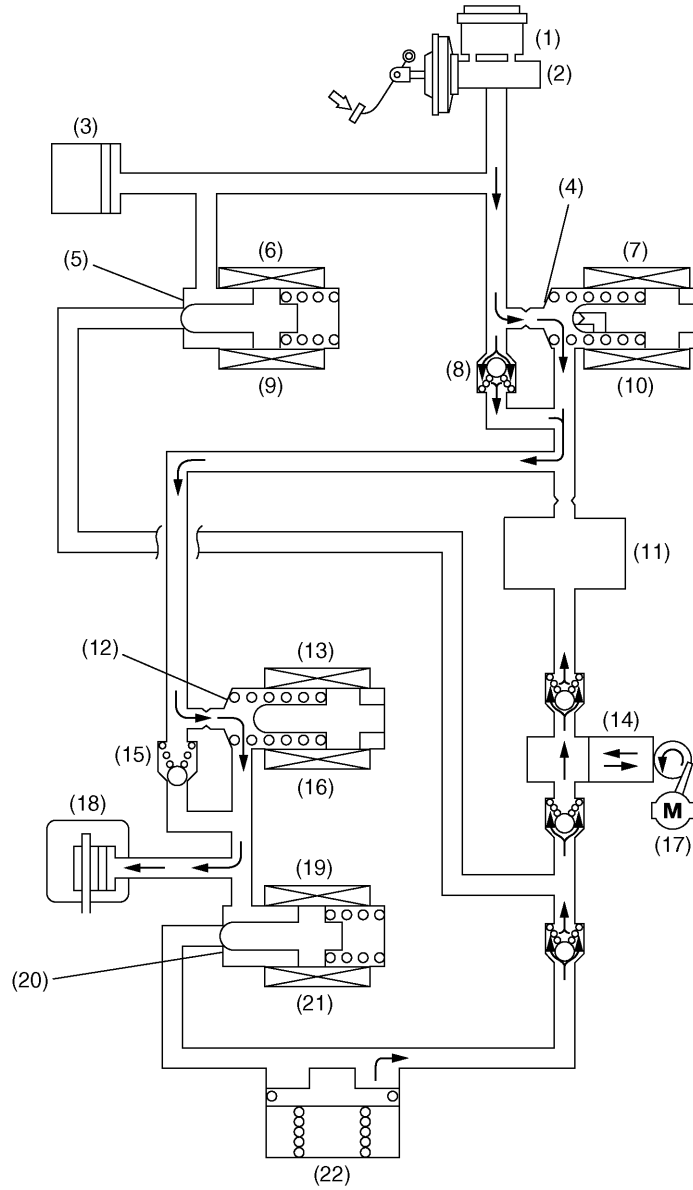

B4H1640B

- | | | |
|----------------------------|---------------------------|----------------------------|
| (1) Reservoir tank | (9) De-energized | (17) Motor |
| (2) Master cylinder | (10) De-energized | (18) Wheel cylinder |
| (3) Pressure sensor | (11) Damper chamber | (19) Outlet solenoid valve |
| (4) Port open | (12) Port open | (20) Port closed |
| (5) Port closed | (13) Inlet solenoid valve | (21) De-energized |
| (6) Suction solenoid valve | (14) Pump | (22) Reservoir |
| (7) Cut solenoid valve | (15) Check valve | |
| (8) Check valve | (16) De-energized | |

VDC-15

VEHICLE DYNAMICS CONTROL (VDC) SYSTEM

VDC

5. PRESSURE “INCREASE” CONTROL WITH BRAKE PEDAL NOT DEPRESSED

The cut solenoid valve and suction solenoid valve are energized while the other solenoid valves are not energized. This means that the ports of the cut solenoid valve and outlet solenoid valve are closed, while those of the inlet solenoid valve and suction solenoid valve are open.

In this state, the pump is activated, forcing the brake fluid in the master cylinder reservoir tank into the wheel cylinder through the open port of the suction solenoid valve and then through the open port of the inlet solenoid valve. The brake is then applied with an increased force.

NOTE:

For simplicity of explanation, operation of the hydraulic control unit is represented by operation of a single wheel circuit.

VDC-16

VEHICLE DYNAMICS CONTROL (VDC) SYSTEM

VDC

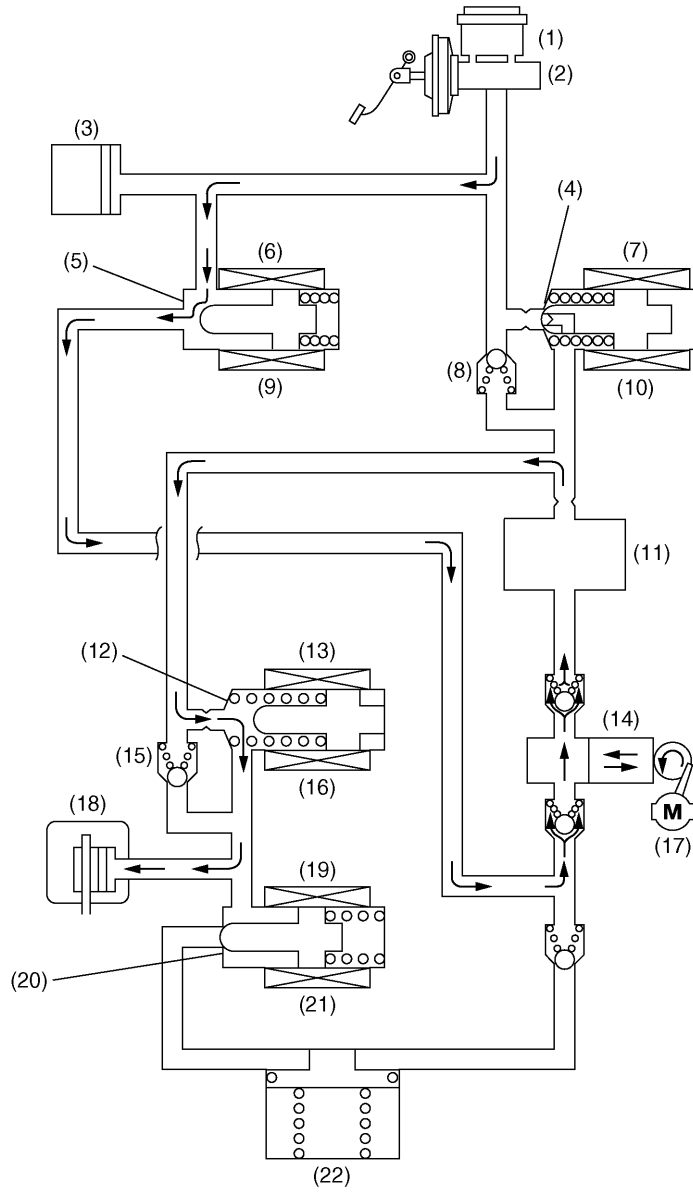

B4H1641B

- | | | |
|----------------------------|---------------------------|----------------------------|
| (1) Reservoir tank | (9) Energized | (17) Motor |
| (2) Master cylinder | (10) Energized | (18) Wheel cylinder |
| (3) Pressure sensor | (11) Damper chamber | (19) Outlet solenoid valve |
| (4) Port closed | (12) Port open | (20) Port closed |
| (5) Port open | (13) Inlet solenoid valve | (21) De-energized |
| (6) Suction solenoid valve | (14) Pump | (22) Reservoir |
| (7) Cut solenoid valve | (15) Check valve | |
| (8) Check valve | (16) De-energized | |

VDC-17

VEHICLE DYNAMICS CONTROL (VDC) SYSTEM

VDC

6. PRESSURE “HOLD” CONTROL WITH BRAKE PEDAL NOT DEPRESSED

The cut solenoid valve, suction solenoid valve and inlet solenoid valve are all energized, while the outlet solenoid valve is de-energized. This means that the ports of the cut solenoid valve, inlet solenoid valve and outlet solenoid valve are closed, while the port of the suction solenoid valve is open.

In this state, the pump is activated, forcing the brake fluid in the master cylinder reservoir tank through the open port of the suction solenoid valve. The fluid passage is, however, blocked by the closed inlet solenoid valve. Since the port of the outlet solenoid valve is also closed, the fluid pressure in the wheel cylinder is held unreleased.

The fluid pressure generated by the pump becomes higher and higher because the port of the inlet solenoid valve is closed. When it reaches a certain level, the built-in relief valve of the cut solenoid valve opens and allows the brake fluid to return into the master cylinder reservoir tank.

NOTE:

For simplicity of explanation, operation of the hydraulic control unit is represented by operation of a single wheel circuit.

VDC-18

VEHICLE DYNAMICS CONTROL (VDC) SYSTEM

VDC

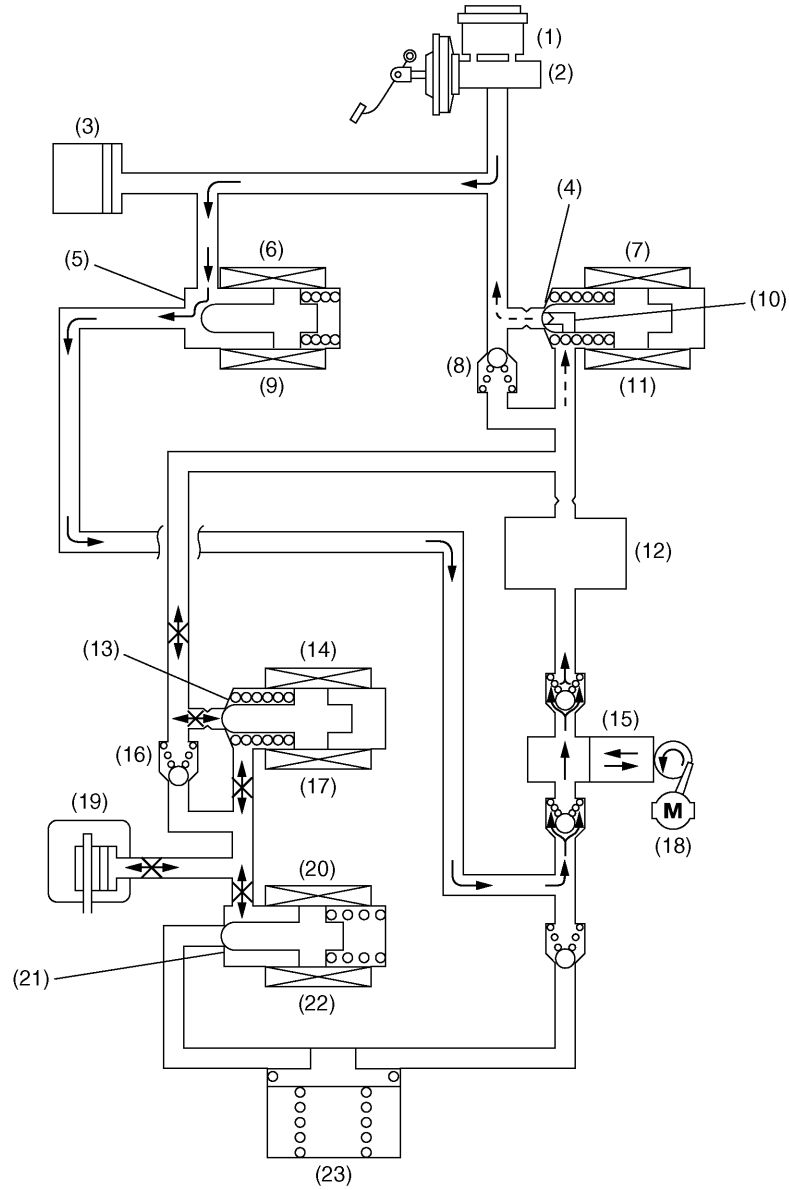

B4H1642B

- | | | |
|----------------------------|---------------------------|----------------------------|
| (1) Reservoir tank | (9) Energized | (17) Energized |
| (2) Master cylinder | (10) Relief valve | (18) Motor |
| (3) Pressure sensor | (11) Energized | (19) Wheel cylinder |
| (4) Port closed | (12) Damper chamber | (20) Outlet solenoid valve |
| (5) Port open | (13) Port closed | (21) Port closed |
| (6) Suction solenoid valve | (14) Inlet solenoid valve | (22) De-energized |
| (7) Cut solenoid valve | (15) Pump | (23) Reservoir |
| (8) Check valve | (16) Check valve | |

VDC-19

VEHICLE DYNAMICS CONTROL (VDC) SYSTEM

VDC

7. PRESSURE “DECREASE” CONTROL WITH BRAKE PEDAL NOT DEPRESSED

The cut solenoid valve, suction solenoid valve, inlet solenoid valve and outlet solenoid valve are all energized. This means that the ports of the cut solenoid valve and inlet solenoid valve are closed, while those of the suction and outlet solenoid valves are open.

In this state, the pump is activated drawing the brake fluid from the reservoir and forcing it toward the master cylinder through the open port of the suction solenoid valve. The fluid passage is blocked by the inlet solenoid valve, so the fluid cannot flow toward the wheel cylinder. Since the port of the outlet solenoid valve is open, on the other hand, the brake fluid in the wheel cylinder is allowed to be drawn into the reservoir, so the fluid pressure in the wheel cylinder decreases. The brake fluid drawn into the reservoir is raised from it and forced into the master cylinder reservoir tank through the suction solenoid valve.

The pressure of the fluid in the passage toward the cut solenoid valve becomes higher and higher as the pump operates since the valve is closed. When the pressure reaches a certain level, the build-in relief valve of the cut solenoid valve opens, releasing the brake fluid into the master cylinder reservoir tank.

NOTE:

For simplicity of explanation, operation of the hydraulic control unit is represented by operation of a single wheel circuit.

VDC-20

VEHICLE DYNAMICS CONTROL (VDC) SYSTEM

VDC

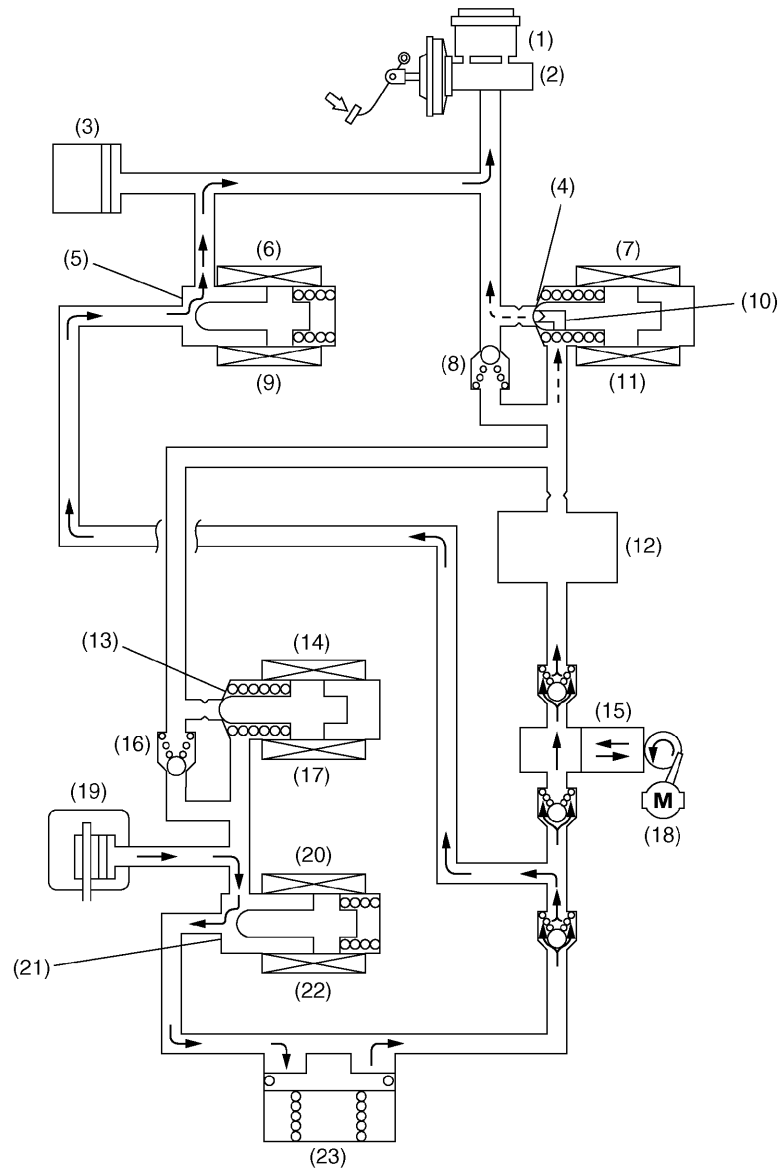

B4H1643B

- | | | |
|----------------------------|---------------------------|----------------------------|
| (1) Reservoir tank | (9) Energized | (17) Energized |
| (2) Master cylinder | (10) Relief valve | (18) Motor |
| (3) Pressure sensor | (11) Energized | (19) Wheel cylinder |
| (4) Port closed | (12) Damper chamber | (20) Outlet solenoid valve |
| (5) Port open | (13) Port closed | (21) Port open |
| (6) Suction solenoid valve | (14) Inlet solenoid valve | (22) Energized |
| (7) Cut solenoid valve | (15) Pump | (23) Reservoir |
| (8) Check valve | (16) Check valve | |

VDC-21

VEHICLE DYNAMICS CONTROL (VDC) SYSTEM

VDC

MEMO

VDC-22