

GENERAL DESCRIPTION

Airbag System

1. General Description S802001

A: COMPONENT S802001A05

1. SRS AIRBAG S802001A0501

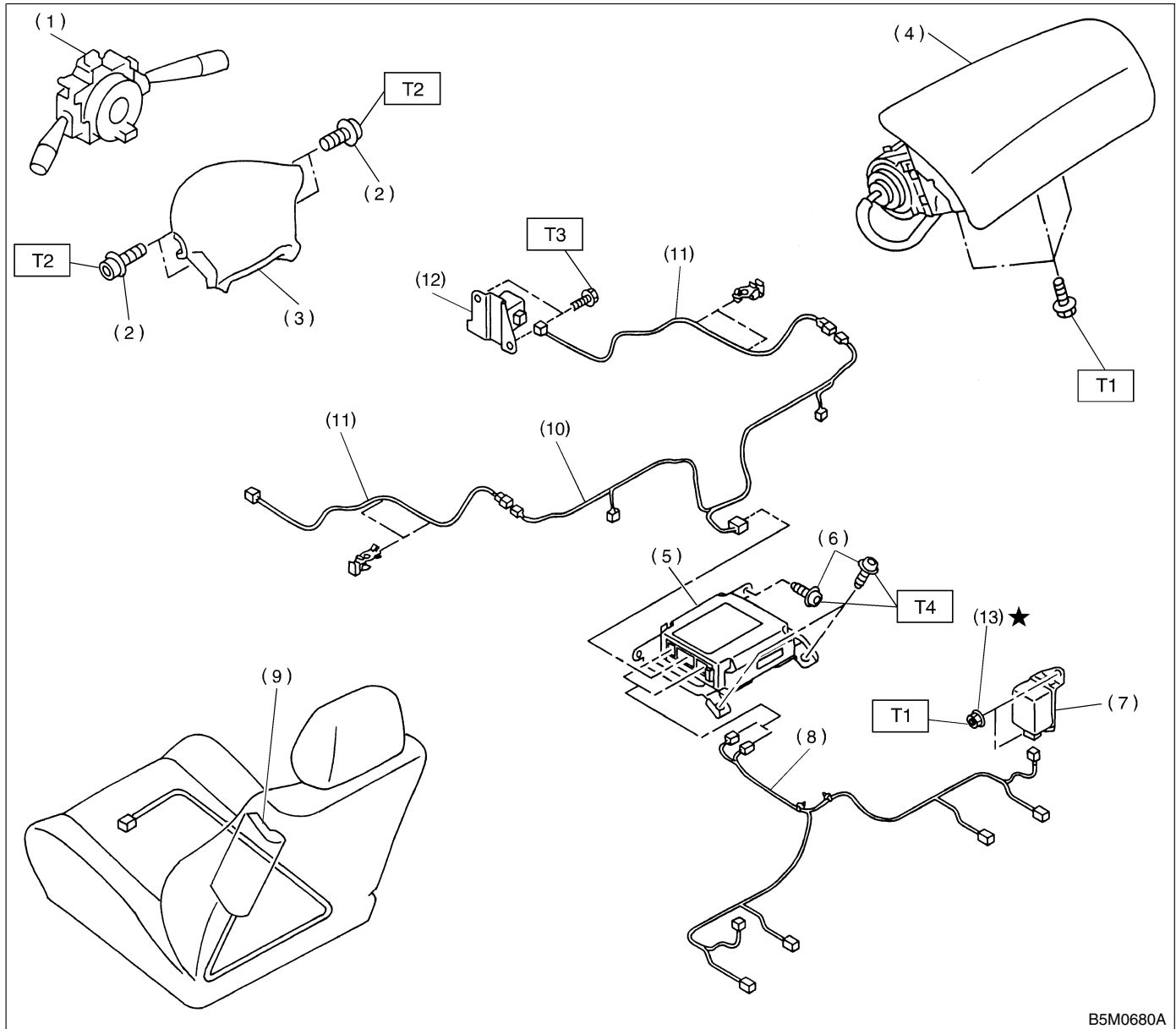

- (1) Combination switch ASSY with roll connector
- (2) TORX® bolt T30
- (3) Airbag module ASSY (Driver)
- (4) Airbag module ASSY (Passenger)
- (5) Airbag control module
- (6) TORX® bolt T40

- (7) Side airbag sensor
- (8) Side airbag harness
- (9) Side airbag module
- (10) Airbag main harness
- (11) Front sub sensor harness
- (12) Front sub sensor
- (13) TORX® nut E12

Tightening torque: N·m (kgf·m, ft·lb)

T1: 7.4±2.0 (0.75±0.2, 5.4±1.4)

T2: 10±2 (1.0±0.2, 7.2±1.4)

T3: 20±4 (2.0±0.4, 14.5±2.9)

T4: 25±2 (2.5±0.2, 18.1±1.4)

B: CAUTION S802001A03

- When servicing a vehicle, be sure to turn the ignition switch OFF, disconnect the ground cable from the battery, and wait for more than 20 seconds before starting work.
- The airbag system is fitted with a backup power source. If the airbag system is serviced within 20 seconds after the ground cable is disconnected, it may inflate.

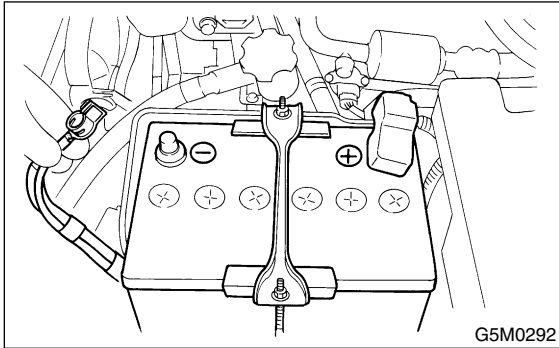

- If sensors, air bag module, airbag control module, pretensioner and harness are deformed or damaged, replace them with new genuine parts.
- Do not use the airbag system and pretensioners on other vehicles. When replacing parts, be sure to replace them with new parts.

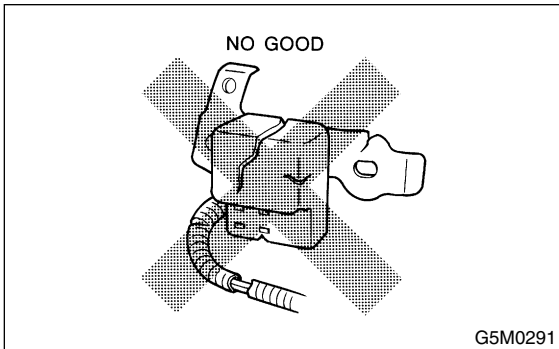

- When checking the system, be sure to use a digital circuit tester. Use of an analog circuit tester may cause the airbag to activate erroneously.

- When checking, use a test harness. Do not directly apply the tester probe to any connector terminal of the airbag.

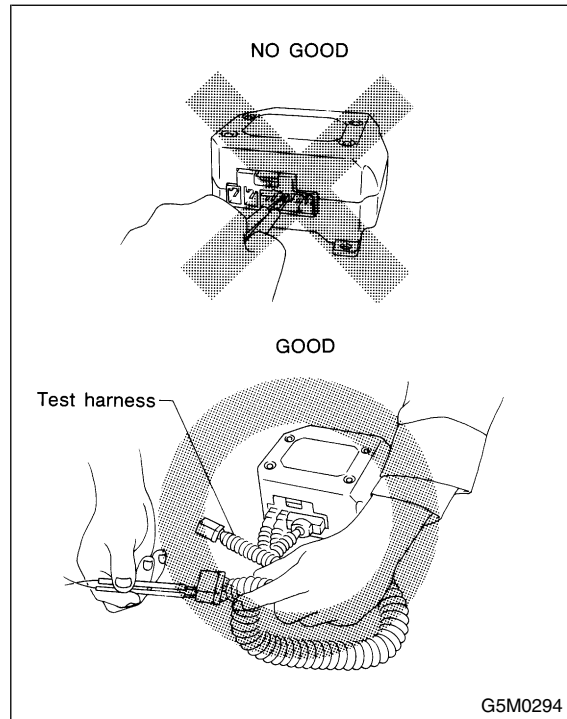
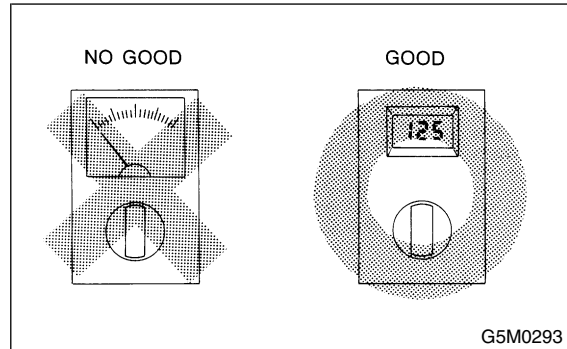

GENERAL DESCRIPTION

Airbag System

- Do not drop the airbag modulator parts, subject them to high temperature over 93°C (199°F), or let water, oil, or grease get on them; otherwise, the internal parts may be damaged and reliability greatly lowered.

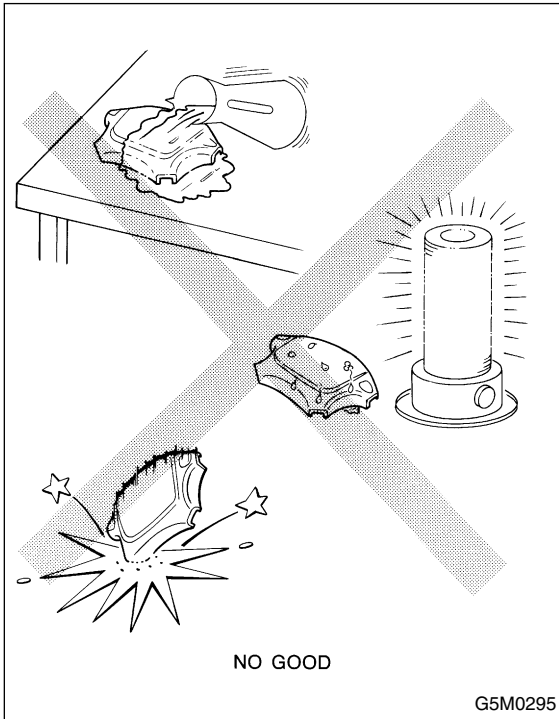

- If any damage, opening, rust is found on the airbag system wire harness, do not attempt to repair using soldering equipment. Be sure to replace the faulty harness with a new genuine part.

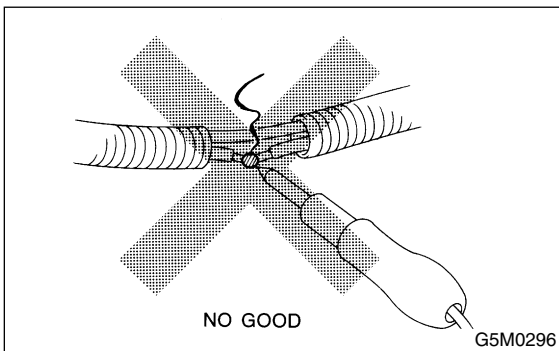

- Install the wire harness securely with the specified clips to avoid interference or tangled up with other parts.

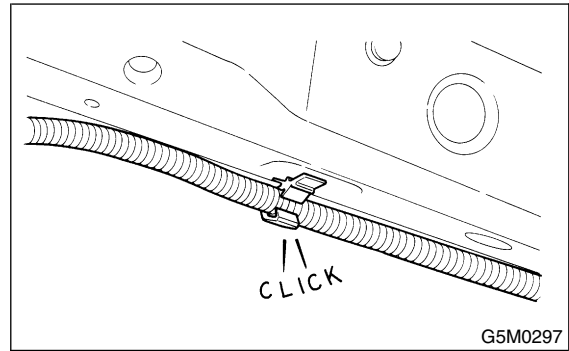

- Do not allow water or oil to come in contact with the connector terminals. Do not touch the connector terminals.

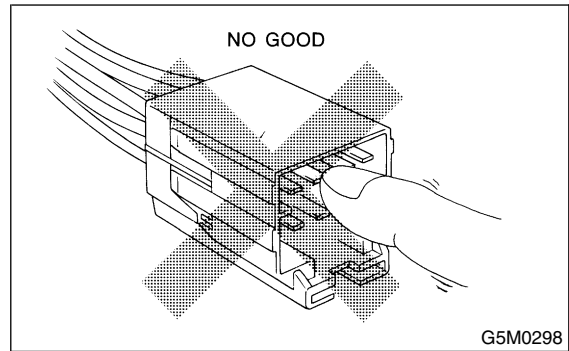

- The airbag module (driver, passenger, and side, pretensioner) must not be disassembled.
- The airbag module cannot be used again once inflated.

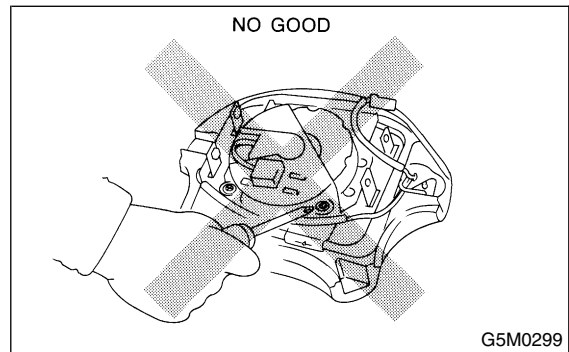

- After removal, keep the airbag module with the pad facing upward on a dry, clean, and flat surface away from heat and light sources, and moisture and dust.

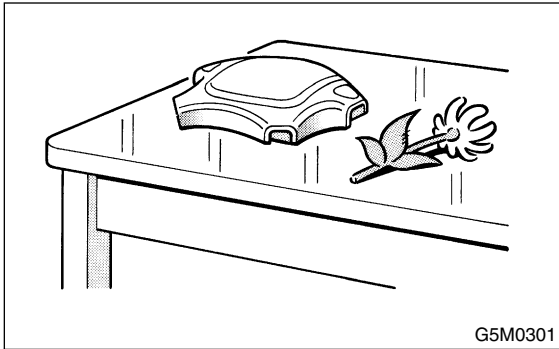

- Do not check continuity of the airbag module (driver, passenger, and side, pretensioner).

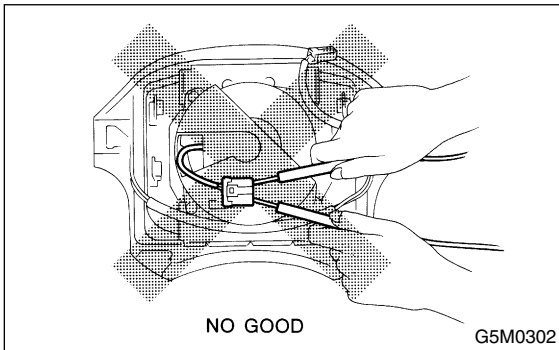

- The removed front seat with the airbag module must be kept at least 200 mm (8 in) away from walls and other objects.

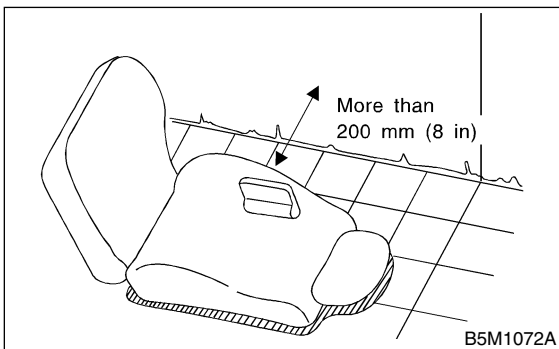

- Do not use the airbag or pretensioner parts from other vehicles. Always replace parts with new parts.
- Do not re-use deployed airbag or pretensioner again.
- When painting or performing sheet metal work on the front part of the vehicle, including the front wheel apron, front fender, and front side frame, take utmost care not to apply paint or the flame of the welding burner directly to the front sub sensors and wire harness of the airbag system.
- When painting or performing sheet metal work on the side of the vehicle, including the side sill, center pillar, and front and rear doors, take utmost care not to apply paint or the flame of the welding burner directly to the side airbag sensors and wire harness of the airbag system.

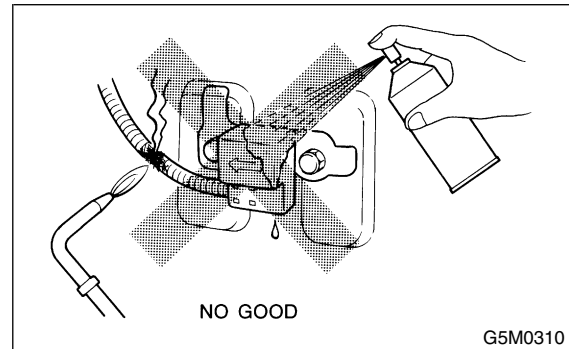

- When storing a removed airbag module, do not place any objects on it or pile airbag modules on top of each other. If the airbag inflates for some reason when it is placed with its pad side facing downward or under any object, a serious accident may result.

GENERAL DESCRIPTION

Airbag System

Driver side

GOOD

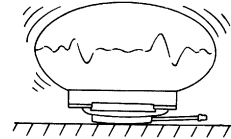
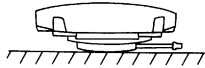

NO GOOD

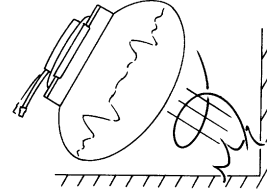
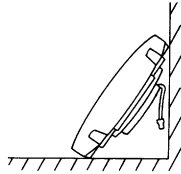

NO GOOD

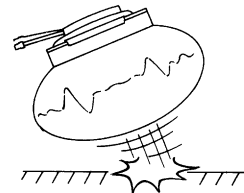
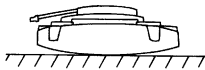

NO GOOD

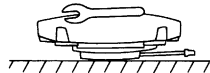

Passenger side

GOOD

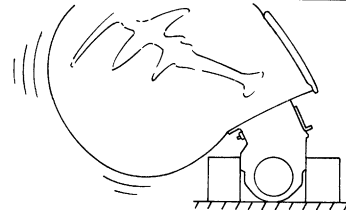
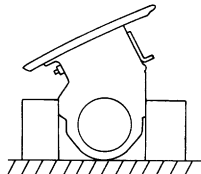

NO GOOD

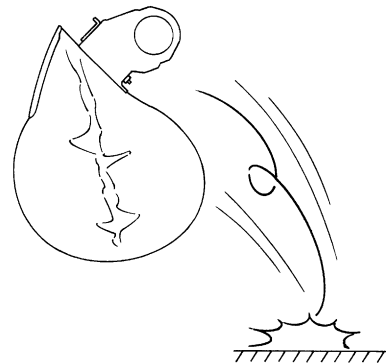
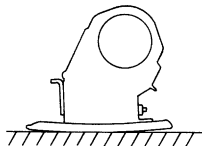

NO GOOD

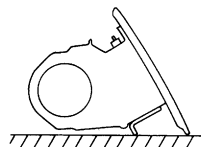

G5M0604

● Do not discard undeployed airbag modules. They could easily cause a serious accident if accidentally deployed.

● Do not damage the airbag module or drop it.

C: PREPARATION TOOL S802001A17

1. GENERAL TOOL S802001A1701

TOOL NAME	REMARKS
TORX [®] T30	Used for removal/installation of driver's airbag module.
TORX [®] T40 (Tamper resistant type)	Used for removal/installation of airbag control module.
TORX [®] E12	Used for removal of side airbag sensor.