

GENERAL DESCRIPTION

Power Assisted System (Power Steering)

1. General Description S601001

A: SPECIFICATIONS S601001E49

Model			Except OUTBACK	OUTBACK	
				2.5 ℓ model	3.0 ℓ model
Whole system	Minimum turning radius	m (ft)	5.4±0.5 (17.7±1.6)	5.6±0.5 (18.4±1.6)	
	Steering angle (Inside-Outside)		36.3°±1.5° — 31.6°±1.5°	34.5°±1.5° — 30.3°±1.5°	
	Steering wheel diameter	mm (in)	385 (15.16)		
	Overall gear ratio (Turns, lock to lock)		16.5 (3.2)	19.0 (3.4)	
Gearbox	Type		Rack and pinion, Integral		
	Backlash		0 (Automatically adjustable)		
	Valve (Power steering system)		Rotary valve		
Pump (Power steering system)	Type		Vane pump		
	Oil tank		Installed on body		
	Output	cm ³ (cu in)/rev.	7.2 — 0.6 (0.439 — 0.037)	9.6 — 0.65 (0.586 — 0.040)	
	Relief pressure	kPa (kg/cm ² , psi)	9,807 (100, 1,422)	7,846 (80, 1,138)	
	Hydraulic fluid control		Dropping in response to increased engine revolutions		
	Hydraulic fluid	ℓ (US qt, Imp qt)	1,000 rpm: 6 (6.3, 5.3) 3,000 rpm: 5 (5.3, 4.4)	1,000 rpm: 7 (7.4, 6.2) 3,000 rpm: 5 (5.3, 4.4)	
	Range of revolution	rpm	500 — 9,000	500 — 8,000	
	Revolving direction		Clockwise		
Working fluid (Power steering system)	Name		ATF DEXRON IIE or III		
	Capacity	Oil tank	ℓ (US qt, Imp qt)	0.3 (0.3, 0.3)	
		Total	ℓ (US qt, Imp qt)	0.7 (0.7, 0.6)	

GENERAL DESCRIPTION

Power Assisted System (Power Steering)

Steering wheel	Free play		mm (in)	17 (0.67)
Turning angle	Inner tire & wheel	Except OUTBACK model		36.3°±1.5°
		OUTBACK model		34.5°±1.5°
	Outer tire & wheel	Except OUTBACK model		31.6°±1.5°
		OUTBACK model		30.3°±1.5°
Steering shaft	Clearance between steering wheel and column cover		mm (in)	3.0 (0.118)
Steering gear-box (Power steering system)	Sliding resistance		N (kgf, lb)	304.0 (31.0, 68.4) or less
	Rack shaft play in radial direction	Right-turn steering	mm (in)	0.15 (0.0059) or less
		Left-turn steering	mm (in)	Horizontal movement: 0.3 (0.012) or less Vertical movement: 0.15 (0.0059) or less
	Input shaft play	In radial direction	mm (in)	0.18 (0.0071) or less
		In axial direction	mm (in)	0.1 (0.004) or less
	Turning resistance		N (kgf, lb)	Within 30 mm (1.18 in) from rack center in straight ahead position: Less than 11.18 (1.14, 2.51) Maximum allowable value: 12.7 (1.3, 2.9)
Oil pump (Power steering system)	Pulley shaft	Radial play	mm (in)	0.4 (0.016) or less
		Axial play	mm (in)	0.6 (0.024) or less
	Pulley	Ditch deflection	mm (in)	1.0 (0.039) or less
		Resistance to rotation	N (kgf, lb)	9.22 (0.94, 2.07) or less
	Regular pressure		kPa (kg/cm ² , psi)	981 (10, 142) or less
	Relief pressure		kPa (kg/cm ² , psi)	9,807 (100, 1,422)
Steering wheel effort (Power steering system)	At standstill with engine idling on a concrete road		N (kgf, lb)	29.4 (3.0, 6.6) or less
	At standstill with engine stalled on a concrete road		N (kgf, lb)	294.2 (30, 66.2) or less

Recommended power steering fluid	Manufacturer
ATF DEXRON III or equivalent	B.P.
	CALTEX
	CASTROL
	MOBIL
	SHELL
	TEXACO

GENERAL DESCRIPTION

Power Assisted System (Power Steering)

CAUTION:

This table lists various clearances that must be correctly adjusted to ensure normal vehicle driving without interfering noise, or any other faults.

Location	Minimum allowance	
	2.5 ℓ model	3.0 ℓ model
(1) Crossmember — Pipe	5 mm (0.20 in)	
(2) DOJ — Shaft or joint	14 mm (0.55 in)	
(3) DOJ — Valve housing	11 mm (0.43 in)	
(4) Pipe — Pipe	2 mm (0.08 in)	
(5) Stabilizer — Pipe	5 mm (0.20 in)	
(6) Exhaust pipe — Pipe	15 mm (0.59 in)	
(7) Exhaust pipe — Gearbox boot	15 mm (0.59 in)	
(8) Side frame — Hose A and B	15 mm (0.59 in)	
(9) Cruise control pump — Hose A and B	15 mm (0.59 in)	
(10) Pipe portion of hose A — Pipe portion of hose B	1.5 mm (0.059 in)	—
(11) AT cooling hose — Joint	20 mm (0.79 in)	—
(12) Pressure hose — Return hose	—	1.5 mm (0.059 in)

GENERAL DESCRIPTION

Power Assisted System (Power Steering)

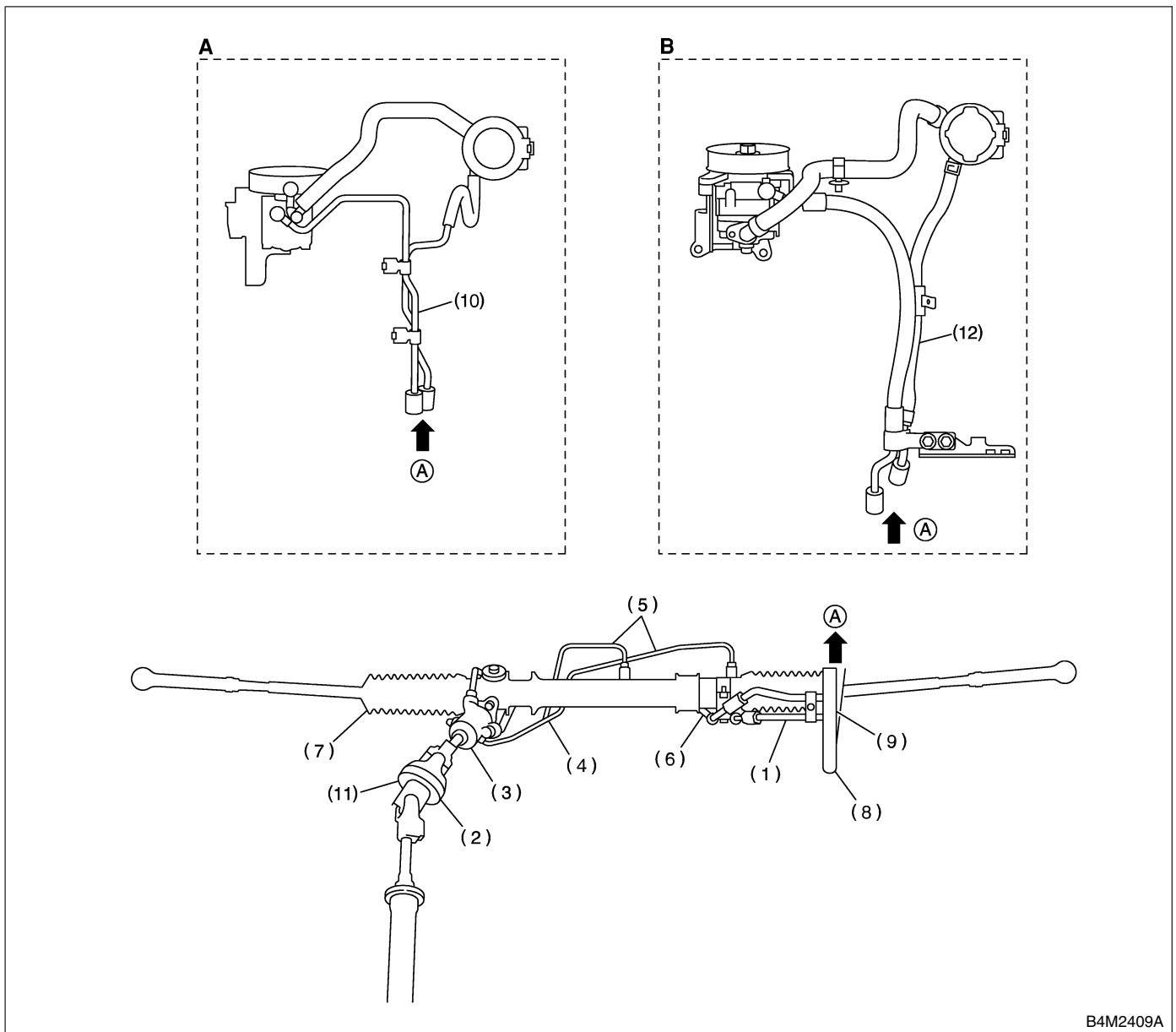

B4M2409A

(A) 2.5 l model

(B) 3.0 l model

GENERAL DESCRIPTION

Power Assisted System (Power Steering)

MEMO:

GENERAL DESCRIPTION

Power Assisted System (Power Steering)

B: COMPONENT S601001A05

1. STEERING WHEEL AND COLUMN S601001A0501

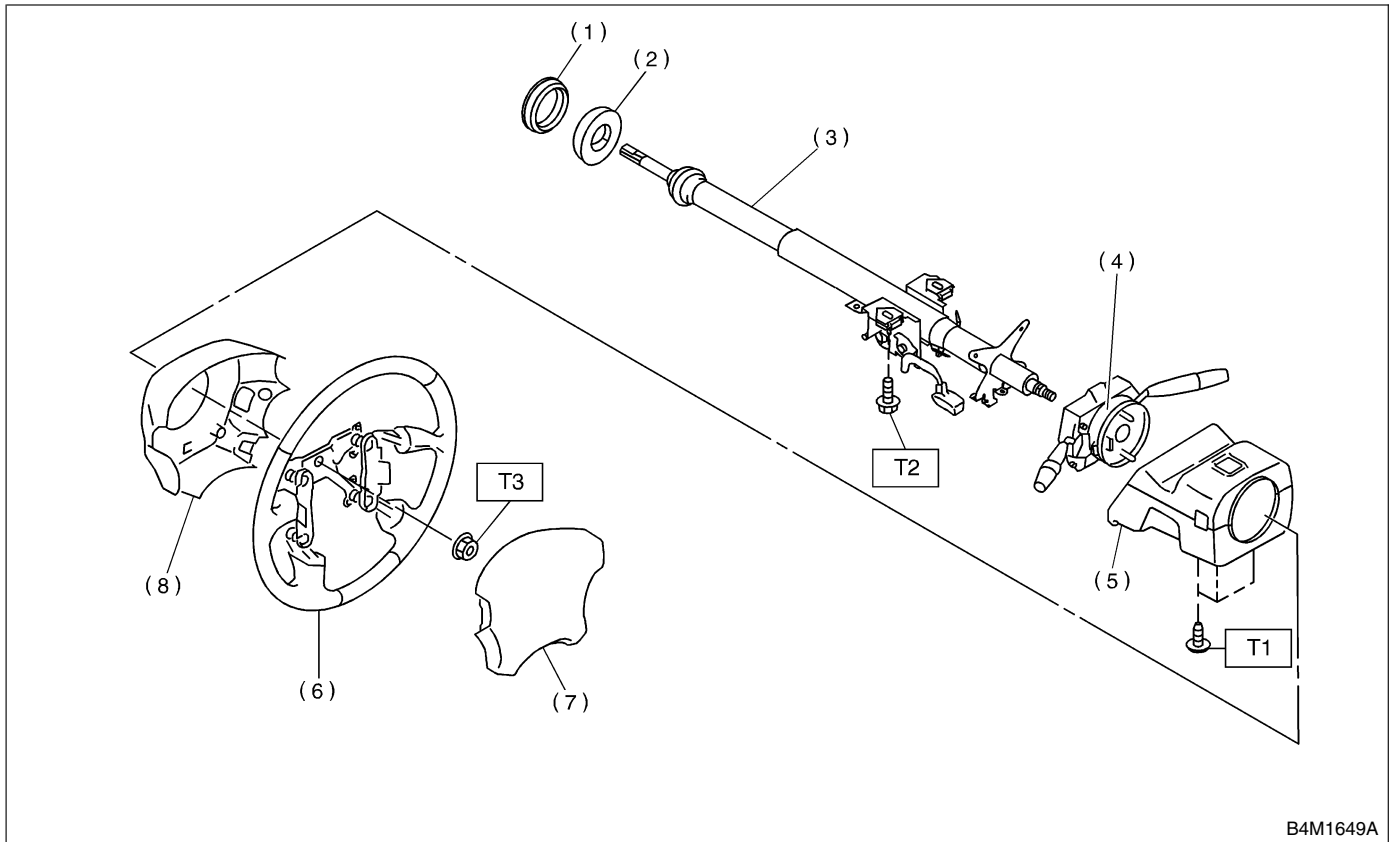

- (1) Bushing
- (2) Seal
- (3) Steering shaft
- (4) Steering roll connector
- (5) Column cover
- (6) Steering wheel
- (7) Airbag module
- (8) Lower steering wheel cover

Tightening torque: N-m (kgf-m, ft-lb)

T1: 1.2 (0.12, 0.9)

T2: 25 (2.5, 18.1)

T3: 44 (4.5, 32.5)

GENERAL DESCRIPTION

Power Assisted System (Power Steering)

2. POWER ASSISTED SYSTEM S601001A0502

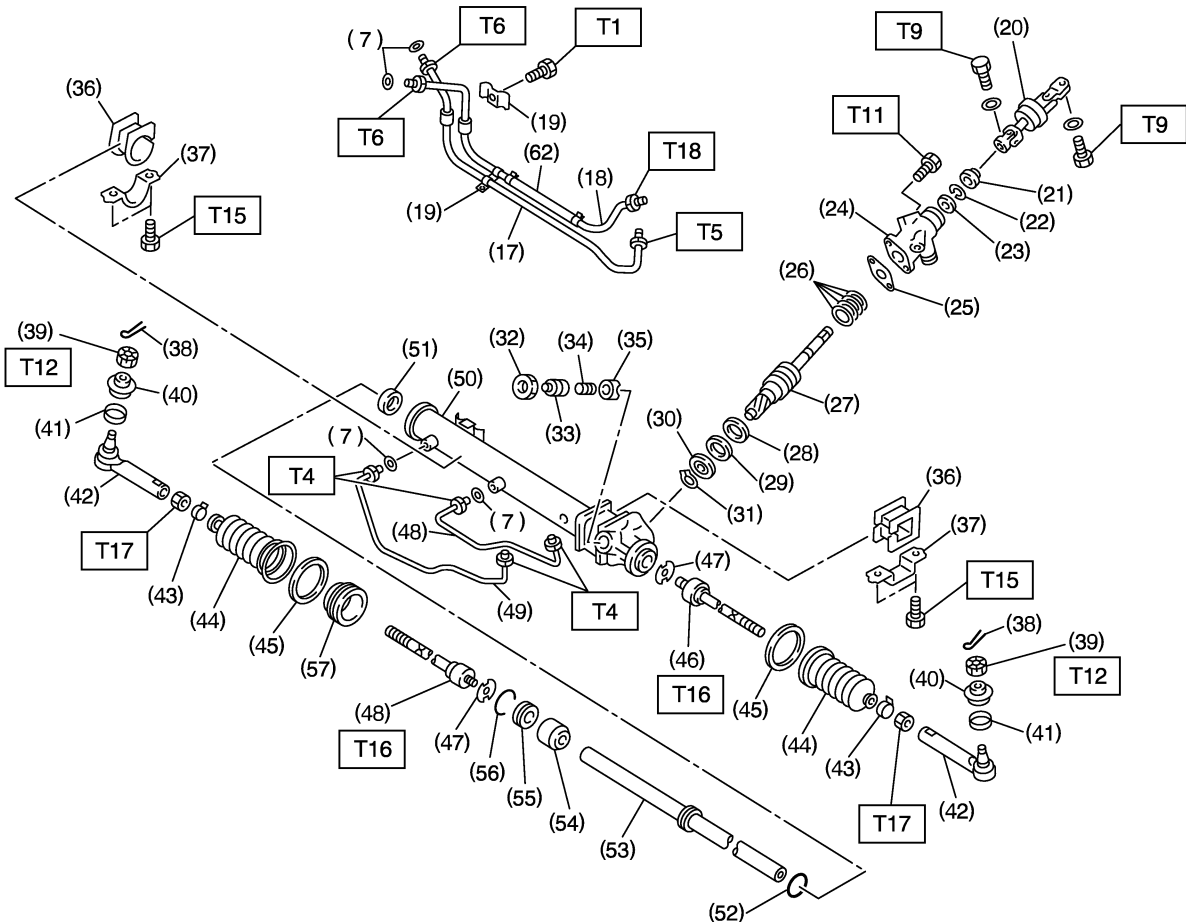
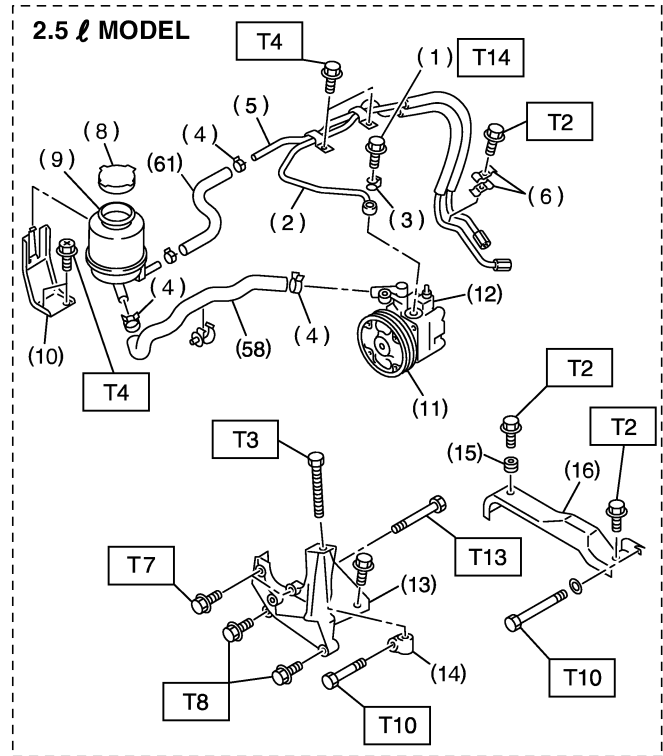
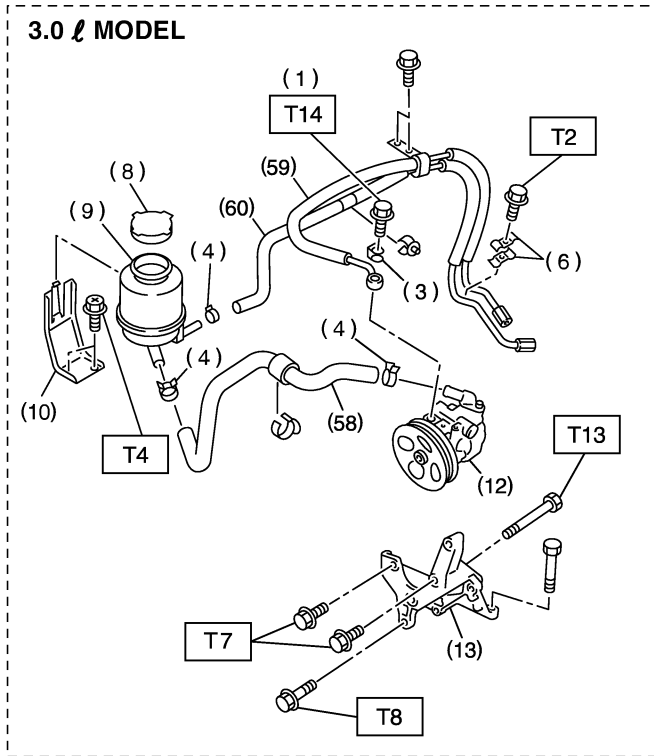

B4M2410B

GENERAL DESCRIPTION

Power Assisted System (Power Steering)

(1) Eye bolt	(29) Back-up washer	(57) Spacer
(2) Pipe C	(30) Ball bearing	(58) Suction hose
(3) Gasket	(31) Snap ring	(59) Pressure hose ASSY
(4) Clip	(32) Lock nut	(60) Return hose ASSY
(5) Pipe D	(33) Adjusting screw	(61) Return hose
(6) Clamp E	(34) Spring	(62) Hose
(7) O-ring	(35) Sleeve	
(8) Cap	(36) Adapter	
(9) Reservoir tank	(37) Clamp	
(10) Reservoir tank bracket	(38) Cotter pin	
(11) Pulley	(39) Castle nut	
(12) Oil pump	(40) Dust cover	
(13) Bracket	(41) Clip	
(14) Belt tension nut	(42) Tie-rod end	
(15) Bushing	(43) Clip	
(16) Belt cover	(44) Boot	
(17) Pipe E	(45) Band	
(18) Pipe F	(46) Tie-rod	
(19) Clamp plate	(47) Lock washer	
(20) Universal joint	(48) Pipe B	
(21) Dust seal	(49) Pipe A	
(22) C-ring	(50) Steering body	
(23) Oil seal	(51) Oil seal	
(24) Valve housing	(52) Piston ring	
(25) Gasket	(53) Rack	
(26) Seal ring	(54) Rack bushing	
(27) Pinion and valve ASSY	(55) Rack stopper	
(28) Oil seal	(56) Circlip	

Tightening torque: N-m (kgf-m, ft-lb)

T1: 6 (0.6, 4.3)

T2: 7.4 (0.75, 5.4)

T3: 8 (0.8, 5.8)

T4: 13 (1.3, 9.4)

T5: 15 (1.5, 10.8)

T6: 15 (1.5, 10.8)

T7: 15.7 (1.6, 11.6)

T8: 22 (2.2, 15.9)

T9: 24 (2.4, 17.4)

T10: 25 (2.5, 18.1)

T11: 25 (2.5, 18.1)

T12: 27 (2.75, 19.9)

T13: 37.3 (3.8, 27.5)

T14: 39 (4.0, 28.9)

T15: 59 (6.0, 43)

T16: 78 (8.0, 58)

T17: 83 (8.5, 61.5)

T18: 25 (2.5, 18.1)

GENERAL DESCRIPTION

Power Assisted System (Power Steering)

3. OIL PUMP S601001A0503

NOTE:

The illustration for 2.5 ℓ model is shown below.
(Not shown for 3.0 ℓ model because it cannot be disassembled.)

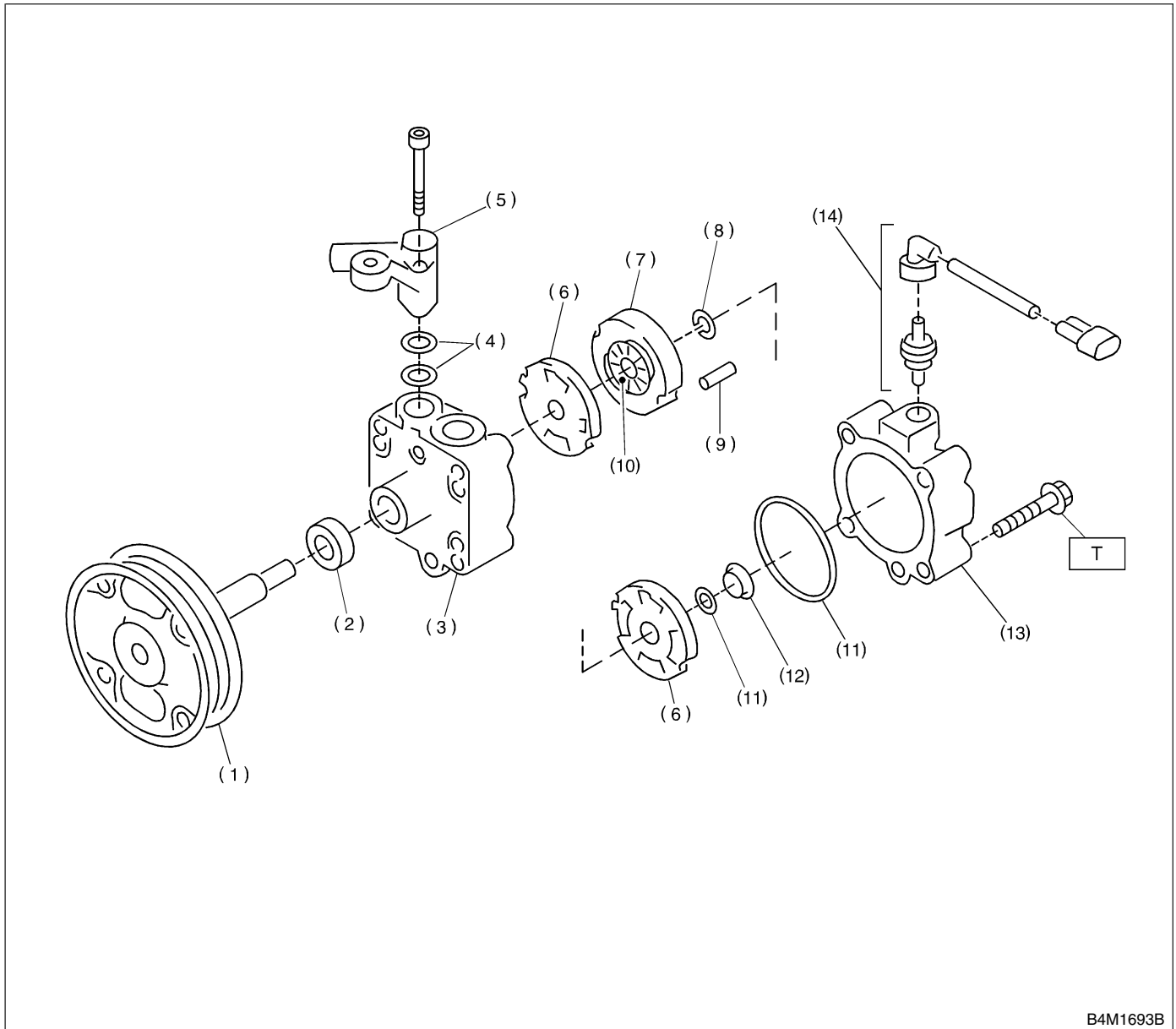

B4M1693B

- (1) Pulley
- (2) Oil seal
- (3) Front casing
- (4) O-ring
- (5) Socket
- (6) Pressure plate

- (7) Cam ring
- (8) Circlip
- (9) Straight pin
- (10) Rotor
- (11) O-ring
- (12) Seal ring

- (13) Rear body
- (14) Connector

Tightening torque: N·m (kgf·m, ft·lb)

T: 27.5 (2.8, 20.3)

C: CAUTION S601001A03

- Wear working clothing, including a cap, protective goggles, and protective shoes during operation.
- Remove contamination including dirt and corrosion before removal, installation or disassembly.
- Keep the disassembled parts in order and protect them from dust or dirt.
- Before removal, installation or disassembly, be sure to clarify the failure. Avoid unnecessary removal, installation, disassembly and replacement.
- Be careful not to burn your hands, because each part on the vehicle is hot after running.
- Use SUBARU genuine steering fluid, grease etc. or the equivalent. Do not mix steering fluid, grease etc. with that of another grade or from other manufacturers.
- Be sure to tighten fasteners including bolts and nuts to the specified torque.
- Place shop jacks or safety stands at the specified points.
- Apply steering fluid onto sliding or revolution surfaces before installation.
- Before installing O-rings or snap rings, apply sufficient amount of steering fluid to avoid damage and deformation.
- Before securing a part on a vise, place cushioning material such as wood blocks, aluminum plate, or shop cloth between the part and the vise.

GENERAL DESCRIPTION

Power Assisted System (Power Steering)

D: PREPARATION TOOL S601001A17

1. SPECIAL TOOLS S601001A1701

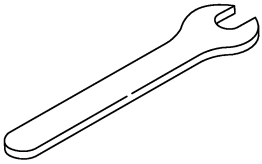
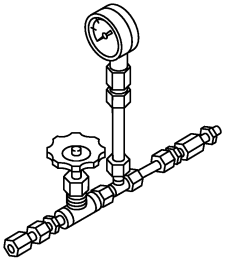
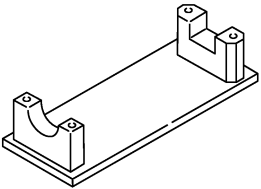
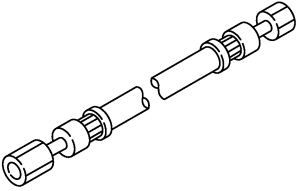
ILLUSTRATION	TOOL NUMBER	DESCRIPTION	REMARKS
 B4M2411	925700000	WRENCH	<ul style="list-style-type: none"> ● Used for removing and installing tie-rod. ● Apply this tool to rack.
 B4M2412	925711000	PRESSURE GAUGE	Used for measuring oil pump pressure.
 B4M2413	926200000	STAND	Used when inspecting characteristic of gearbox assembly and disassembling it.
 B4M2414	34099AC010	ADAPTER HOSE A	Used with PRESSURE GAUGE (925711000).

GENERAL DESCRIPTION

Power Assisted System (Power Steering)

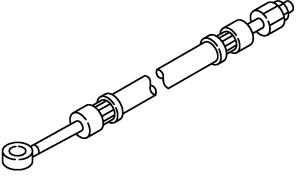
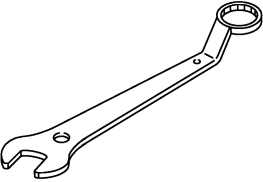
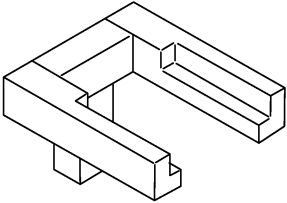
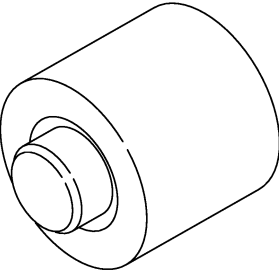
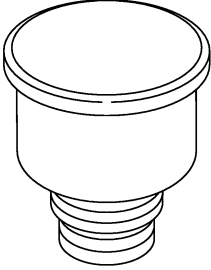
ILLUSTRATION	TOOL NUMBER	DESCRIPTION	REMARKS
 <p data-bbox="363 516 444 533">B4M2415</p>	34099AC020	ADAPTER HOSE B	Used with PRESSURE GAUGE (925711000).
 <p data-bbox="363 873 444 890">B4M2416</p>	926230000	SPANNER	<ul style="list-style-type: none"> ● For the lock nut when adjusting backlash of gearbox. ● Measurement of rotating resistance of gear-box assembly.
 <p data-bbox="363 1230 444 1247">B4M2417</p>	34199AE020	MOUNT	Used for disassembling oil pump.
 <p data-bbox="363 1587 444 1604">B4M2418</p>	34199AE030	INSTALLER	Used for installing oil seal into oil pump.
 <p data-bbox="363 1944 444 1961">B4M2419</p>	34199AE040	OIL CHARGE GUIDE	Used for charging power steering oil.

GENERAL DESCRIPTION

Power Assisted System (Power Steering)

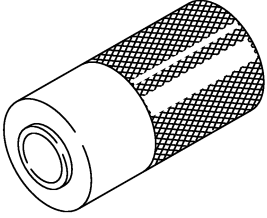
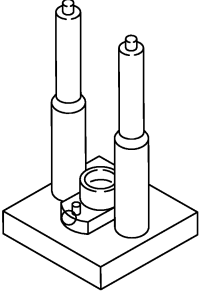
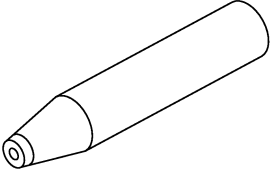
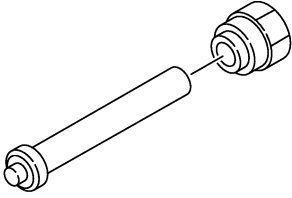
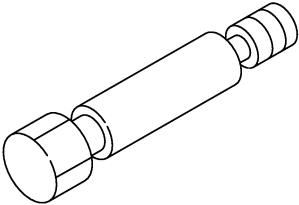
ILLUSTRATION	TOOL NUMBER	DESCRIPTION	REMARKS
 <p style="text-align: center;">B4M2420</p>	927640000	INSTALLER B	Used for installing ball bearing into housing.
 <p style="text-align: center;">B4M2421</p>	926370000	INSTALLER A	<ul style="list-style-type: none"> ● Used for installing valve assembly into valve housing assembly. ● Used with STAND BASE (927630000).
 <p style="text-align: center;">B4M2422</p>	926390001	COVER & REMOVER ASSY	Used for assembling rack assembly.
 <p style="text-align: center;">B4M2423</p>	926420000	PLUG	When oil leaks from pinion side of gearbox assembly, remove pipe B from valve housing, attach this tool and check oil leaking points.
 <p style="text-align: center;">B4M2424</p>	926400000	GUIDE	<ul style="list-style-type: none"> ● Right side of rack when installing rack bushing. ● Used with GUIDE (927660000).

GENERAL DESCRIPTION

Power Assisted System (Power Steering)

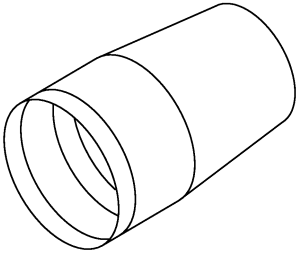
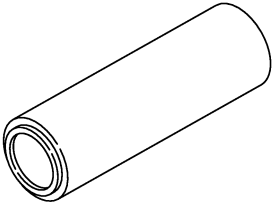
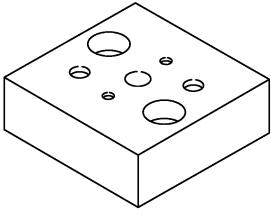
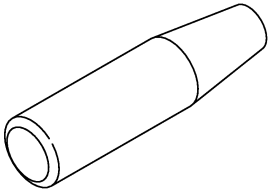
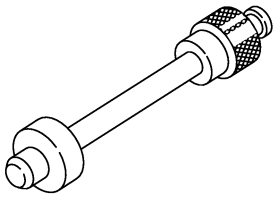
ILLUSTRATION	TOOL NUMBER	DESCRIPTION	REMARKS
 <p>B4M2425</p>	927660000	GUIDE	<ul style="list-style-type: none"> ● Right side of rack when installing rack bushing. ● Used with GUIDE (926400000).
 <p>B4M2426</p>	927620000	INSTALLER B	<ul style="list-style-type: none"> ● Used for installing oil seal of valve housing. ● Used with INSTALLER A (926360000).
 <p>B4M2427</p>	927630000	STAND BASE	Used for assembling power steering gearbox.
 <p>B4M2428</p>	926360000	INSTALLER A	<ul style="list-style-type: none"> ● Used as a guide to install oil seal. ● Used with INSTALLER B (927620000).
 <p>B4M2429</p>	34199AE050	INSTALLER	Used for installing oil seal.

GENERAL DESCRIPTION

Power Assisted System (Power Steering)

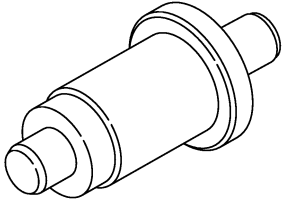
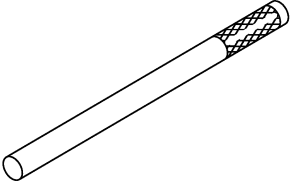
ILLUSTRATION	TOOL NUMBER	DESCRIPTION	REMARKS
 B4M2430	927610000	INSTALLER	Used for installing valve housing oil seal.
 B4M2432	34199AE050	REMOVER OIL SEAL	Used for removing back-up ring and oil seal.

2. GENERAL PURPOSE TOOLS S601001A1702

TOOL NAME	REMARKS
Spring scale	Used for measuring tightening torque.
Snap ring pliers	Used for removing and installing snap ring.
Dial gauge	Used for measuring steering gearbox.