

TILT STEERING COLUMN

Power Assisted System (Power Steering)

4. Tilt Steering Column S601544

A: REMOVAL S601544A18

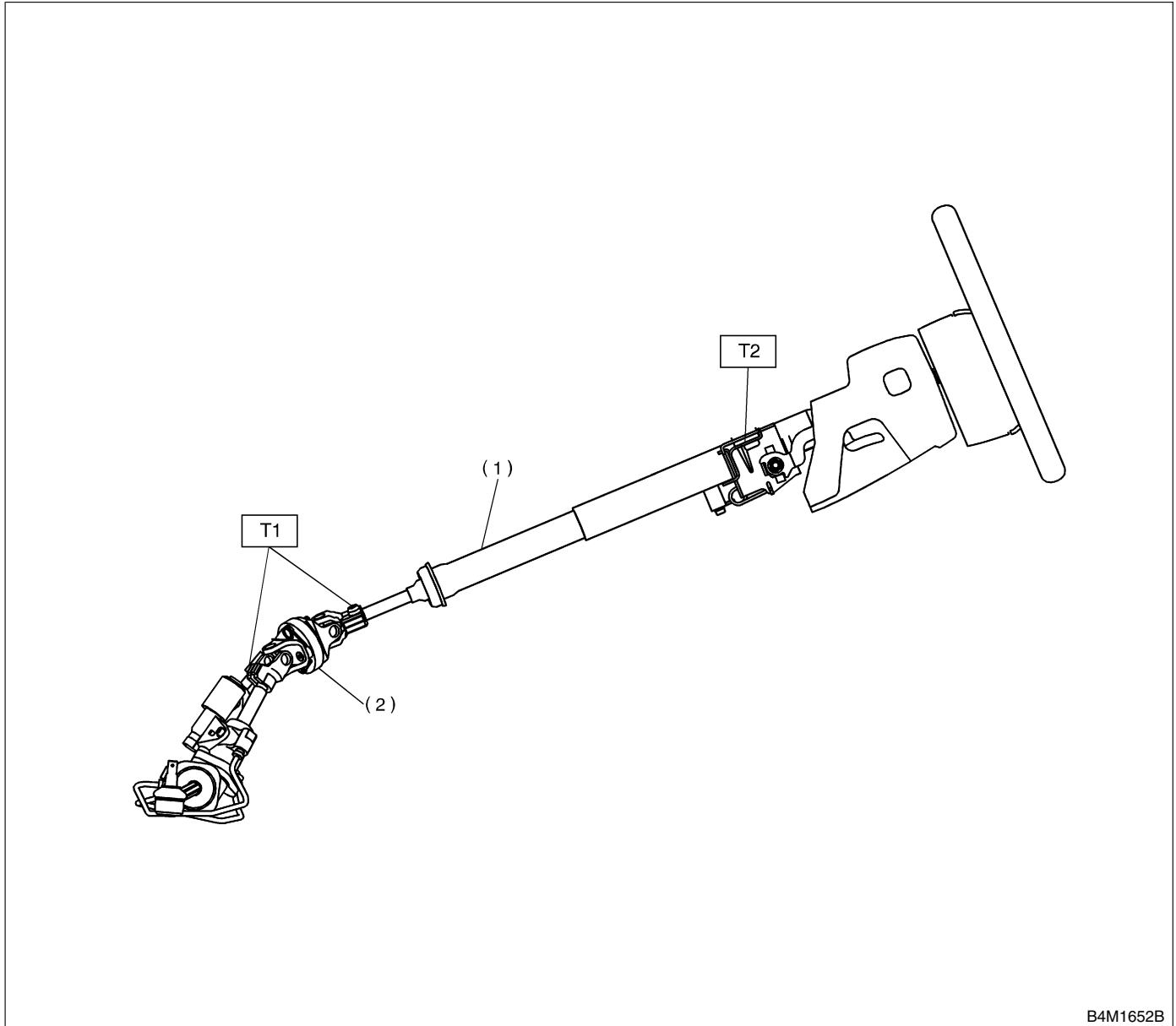

B4M1652B

- (1) Tilt steering column
- (2) Universal joint

Tightening torque: N·m (kgf·m, ft·lb)

T1: 24 (2.4, 17.4)

T2: 25 (2.5, 18.1)

TILT STEERING COLUMN

Power Assisted System (Power Steering)

- 1) Set the vehicle on the lift.
- 2) Disconnect battery ground cable.
- 3) Remove airbag module. <Ref. to AB-13, REMOVAL, Driver's Airbag Module.>

WARNING:

Always refer to "Airbag System" before performing airbag module service. <Ref. to AB-3, CAUTION, General Description.>

- 4) Remove steering wheel. <Ref. to PS-17, REMOVAL, Steering Wheel.>
- 5) Remove universal joint. <Ref. to PS-18, REMOVAL, Universal Joint.>
- 6) Remove trim panel under instrument panel.
- 7) Remove the screw securing lower steering column cover.

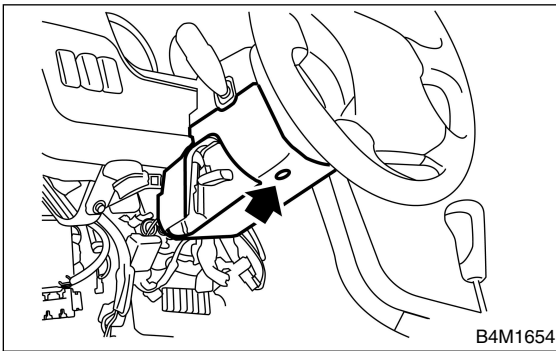

- 8) Remove all connectors from steering column.
- 9) Remove the two bolts under instrument panel securing steering column.

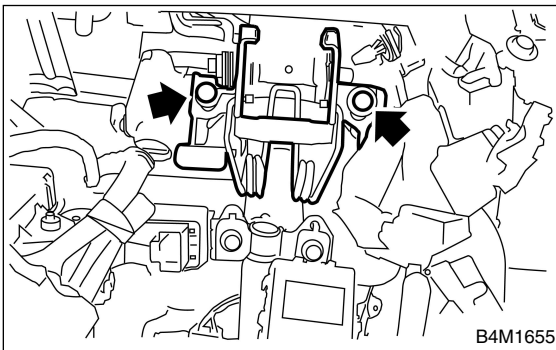

- 10) Pull out steering shaft assembly from hole on toe board.

CAUTION:

Be sure to remove universal joint before removing steering shaft assembly installing bolts when removing steering shaft assembly or when lowering it for servicing of other parts.

B: INSTALLATION S601544A11

- 1) Set grommet to toe board.

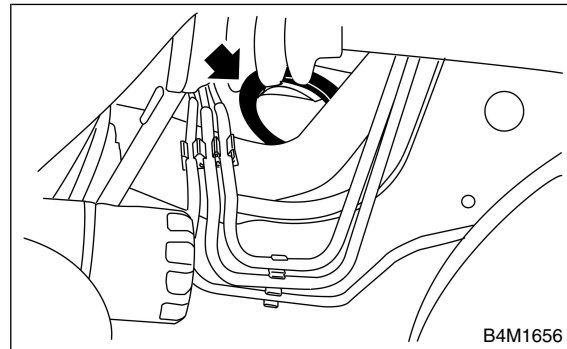

- 2) Insert end of steering shaft into toe board grommet.
- 3) Tighten steering shaft mounting bolts under instrument panel.

Tightening torque:

25 N·m (2.5 kgf·m, 18.1 ft·lb)

- 4) Connect all connectors under instrument panel.
- 5) Connect airbag system connector at harness spool.

NOTE:

Make sure to apply double lock.

- 6) Install lower column cover with tilt lever held in the lowered position.
- 7) Install universal joint. <Ref. to PS-18, INSTALLATION, Universal Joint.>
- 8) Align center of roll connector. <Ref. to AB-20, ADJUSTMENT, Roll Connector.>

CAUTION:

Ensure that front wheels are set in straight forward direction.

- 9) Install steering wheel. <Ref. to PS-17, INSTALLATION, Steering Wheel>
Set steering wheel to neutral and install it onto steering shaft.

CAUTION:

Insert roll connector guide pin into guide hole on lower end of surface of steering wheel to prevent damage. Draw out airbag system connector, horn connector and cruise control connectors from guide hole of steering wheel lower end.

- 10) Install airbag module to steering wheel.

WARNING:

Always refer to "Airbag System" before performing the service operation. <Ref. to AB-3, CAUTION, General Description.>

TILT STEERING COLUMN

Power Assisted System (Power Steering)

C: DISASSEMBLY S601544A06

Remove the two screws securing upper steering column covers, and the two screws securing combination switch, then remove related parts.

D: ASSEMBLY S601544A02

1) Insert combination switch to upper column shaft, and install upper column cover. Then route ignition key harness and combination switch harness between column cover mounting bosses.

Tightening torque:

1.2 N·m (0.12 kgf·m, 0.9 ft-lb)

CAUTION:

Don't overtorque screw.

E: INSPECTION S601544A10

1. BASIC INSPECTION S601544A1001

Clean the disassembled parts with a cloth, and check for wear, damage, or any other faults. If necessary, repair or replace faulty parts.

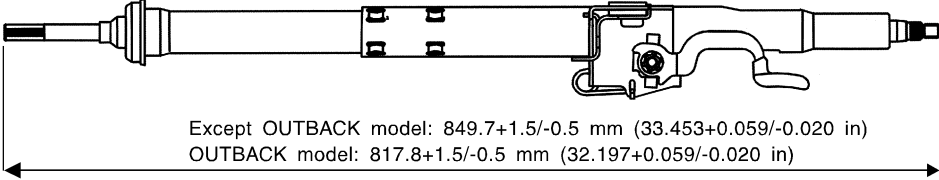
Inspection	Corrective action
<ul style="list-style-type: none"> Overall length of steering column <p>Measure overall length of steering column. Standard overall length of steering column:</p>  <p>Except OUTBACK model: 849.7+1.5/-0.5 mm (33.453+0.059/-0.020 in) OUTBACK model: 817.8+1.5/-0.5 mm (32.197+0.059/-0.020 in)</p> <p>Overall length of steering column</p> <p style="text-align: right;">B4M1712A</p>	<p>Replace steering column assembly.</p>

2. AIRBAG MODEL INSPECTION S601544A1002

WARNING:

For airbag model inspection procedures, refer to "Airbag System". <Ref. to AB-13, INSPECTION, Driver's Airbag Module.>