

6. Pipe Assembly S601277

A: REMOVAL S601277A18

- 1) Disconnect battery ground cable.
- 2) Lift vehicle and remove jack-up plate.

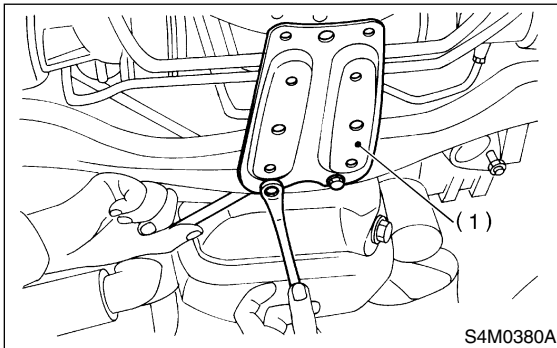

(1) Jack-up plate

- 3) Remove one pipe joint at the center of gearbox, and connect vinyl hose to pipe and joint. Discharge fluid by turning steering wheel fully clockwise and counterclockwise. Discharge fluid similarly from the other pipe.

CAUTION:

Improper removal and installation of parts often causes fluid leak trouble. To prevent this, clean the surrounding portions before disassembly and reassembly, and pay special attention to keep dirt and other foreign matter from mating surfaces.

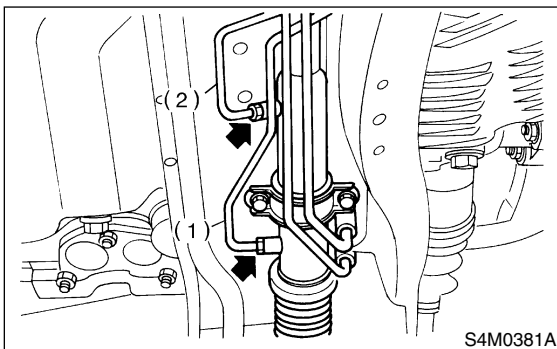

(1) Pipe A
(2) Pipe B

- 4) Remove clamp E from pipes C and D.

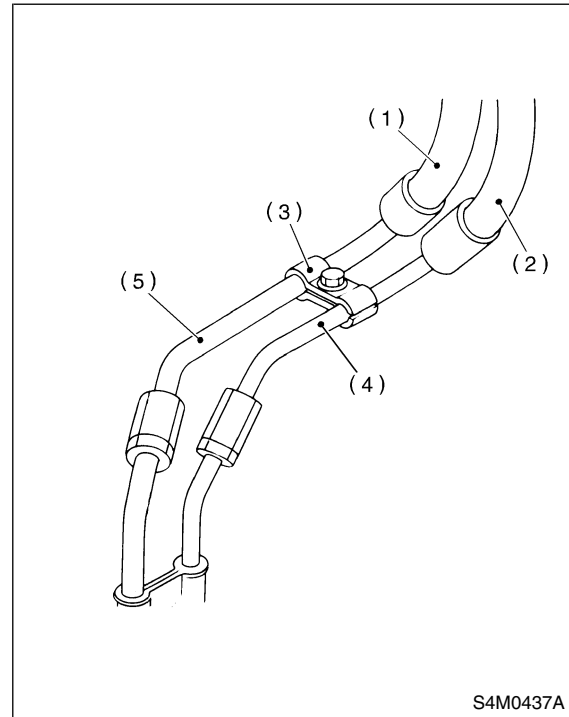

(1) Return hose
(2) Pressure hose
(3) Clamp E
(4) Pipe C
(5) Pipe D

- 5) Disconnect pipe C-D from pipe (on the gearbox side).

CAUTION:

- When disconnecting pipe C-D, use two wrenches to prevent deformities.
- Be careful to keep pipe connections free from foreign matter.

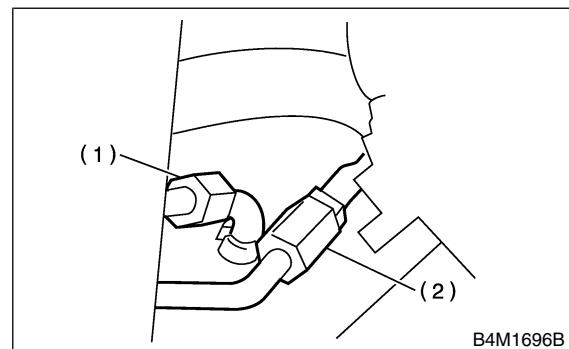

(1) Pipe C
(2) Pipe D

- 6) Remove bolt A.

PIPE ASSEMBLY

Power Assisted System (Power Steering)

2.5 l model:

Disconnect pipe C from oil pump. Disconnect pipe D from return hose.

CAUTION:

- Do not allow fluid from the hose end to come into contact with pulley belt.
- To prevent foreign matter from entering the hose and pipe, cover the open ends of them with a clean cloth.

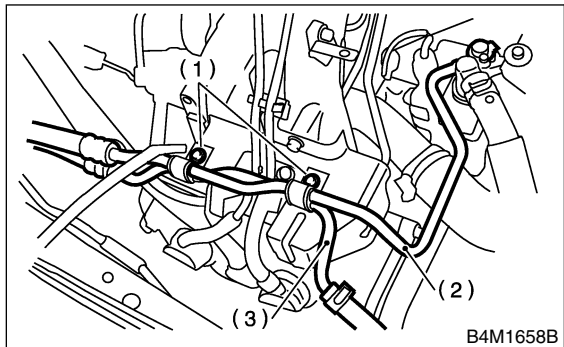

- (1) Bolt A
- (2) Pipe C
- (3) Pipe D

3.0 l model:

Disconnect pressure hose from oil pump. Disconnect return hose from return hose.

CAUTION:

- Do not allow fluid from the hose end to come into contact with pulley belt.
- To prevent foreign matter from entering the hose and pipe, cover the open ends of them with a clean cloth.

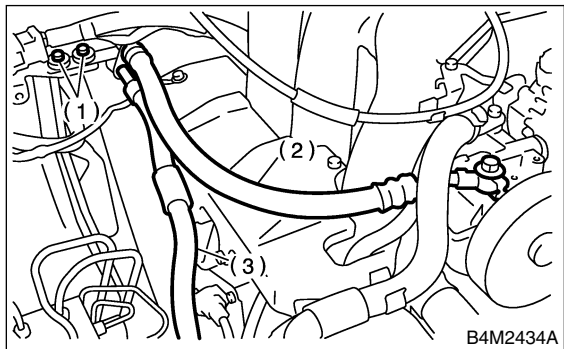

- (1) Bolt A
- (2) Pressure hose
- (3) Return hose

B: INSTALLATION S601277A11

- 1) Tighten bolt A.

CAUTION:

Visually check that hose between tank and pipe D is free from bending or twisting.

2.5 l model:

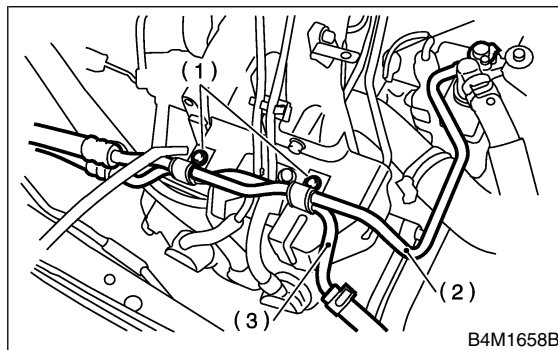

- (1) Bolt A
- (2) Pipe C
- (3) Pipe D

3.0 l model:

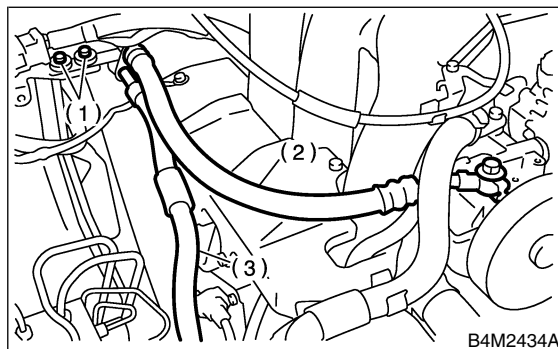

- (1) Bolt A
- (2) Pressure hose
- (3) Return hose

- (1) Connect pipe D or return hose to oil tank.
- (2) Connect pipe C or pressure hose to oil pump.

CAUTION:

Use anew gasket.

Tightening torque:

39 N·m (4.0 kgf·m, 28.9 ft·lb)

- (3) Tighten bolt A.

Tightening torque:

13 N·m (1.3 kgf·m, 9.4 ft·lb)

PIPE ASSEMBLY

Power Assisted System (Power Steering)

2) Temporarily connect pipes C and D to pipes (on the gearbox side).

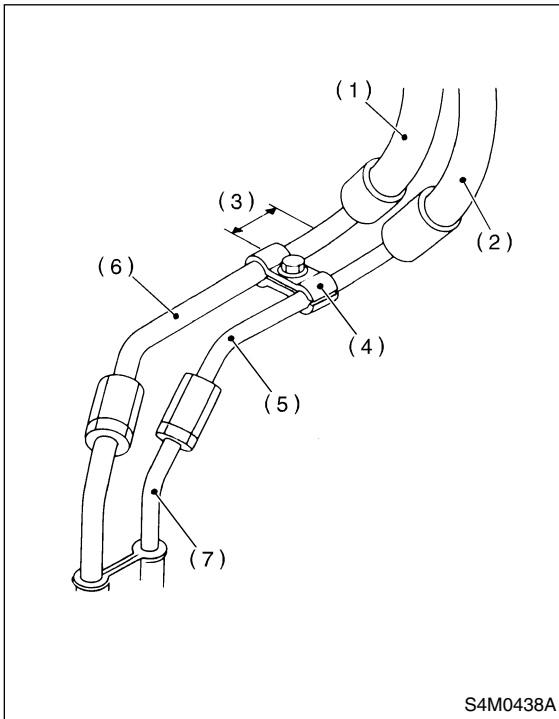

- (1) Return hose
- (2) Pressure hose
- (3) Approx. 30 mm (1.18 in)
- (4) Clamp E
- (5) Pipe C
- (6) Pipe D
- (7) Pipe (on gearbox side)

3) Temporarily install clamp E on pipes C and D.

CAUTION:

Ensure that the letter "8" on each clamp are diagonally opposite each other as shown in figure.

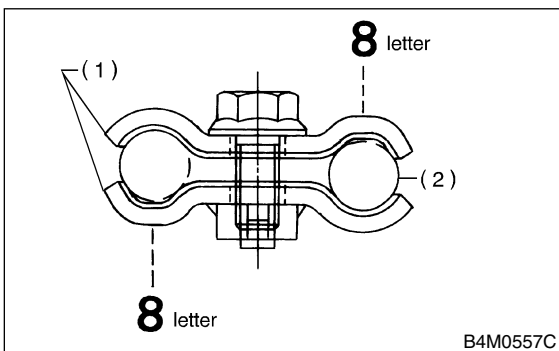

- (1) Clamp E
- (2) Pipe C

4) Tighten clamp E firmly.

Tightening torque:

7.4 N·m (0.75 kgf-m, 5.4 ft-lb)

5) Tighten joint nut.

Tightening torque:

15 N·m (1.5 kgf-m, 10.8 ft-lb)

6) Connect pipes A and B to four pipe joints of gearbox. Connect upper pipe B first, and lower pipe A second.

Tightening torque:

13 N·m (1.3 kgf-m, 9.4 ft-lb)

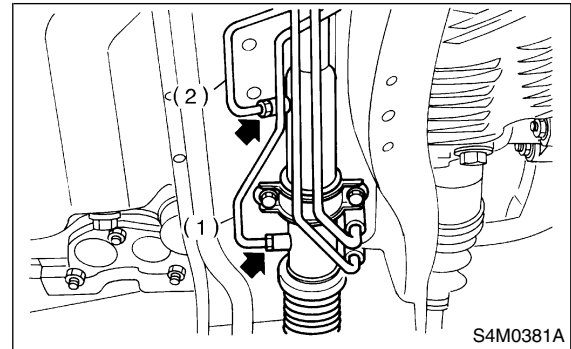

- (1) Pipe A
- (2) Pipe B

7) Install jack-up plate.

8) Connect battery ground cable.

PIPE ASSEMBLY

Power Assisted System (Power Steering)

9) Feed the specified fluid.

NOTE:

Never start the engine before feeding the fluid; otherwise vane pump might be seized up.

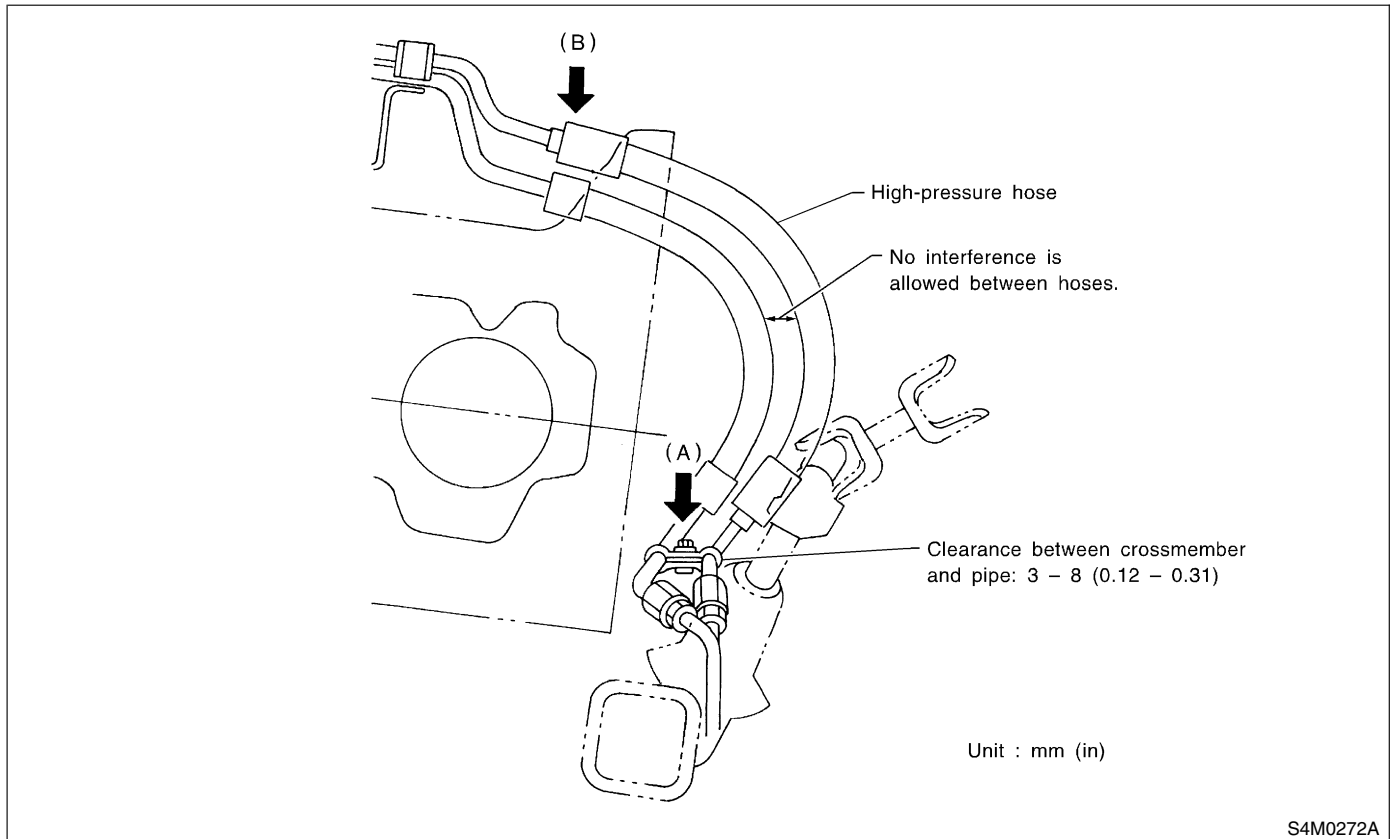

10) Finally check clearance between pipes and/or hoses, as shown above.

If clearance between cruise control pump and power steering hose is less than 10 mm (0.39 in), proceed as follows:

(1) Move clamped section (A) (refer to figure above.) down to a point where pipe is close to crossmember.

Pipe-to-crossmember clearance:
10 mm (0.39 in), min.

(2) Check that clearance between cruise control pump and power steering hose is at least 10 mm (0.39 in). If it is not, bend section (B) down until a clearance of at least 10 mm (0.39 in) is obtained.

C: INSPECTION S601277A10

Check all disassembled parts for wear, damage or other abnormalities. Repair or replace faulty parts as required.

Part name	Inspection	Remedy
Pipe	<ul style="list-style-type: none"> ● O-ring fitting surface for damage ● Nut for damage ● Pipe for damage 	Replace with a new one.
Clamp	<ul style="list-style-type: none"> ● Clamps for weak clamping force 	Replace with a new one.
Hose	<ul style="list-style-type: none"> ● Flared surface for damage ● Flare nut for damage ● Outer surface for cracks ● Outer surface for wear ● Clip for damage ● End coupling or adapter for degradation 	Replace with a new one.

CAUTION:

Although surface layer materials of rubber hoses have excellent weathering resistance, heat resistance and resistance for low temperature brittleness, they are likely to be damaged chemically by brake fluid, battery electrolyte, engine oil and automatic transmission fluid and their service lives are to be very shortened. It is very important to keep the hoses free from before mentioned fluids and to wipe out immediately when the hoses are adhered with the fluids.

Since resistances for heat or low temperature brittleness are gradually declining according to time accumulation of hot or cold conditions for the hoses and their service lives are shortening accordingly, it is necessary to perform careful inspection frequently when the vehicle is used in hot weather areas, cold weather area and/or a driving condition in which many steering operations are required in short time.

Particularly continuous work of relief valve over 5 seconds causes to reduce service lives of the hoses, the oil pump, the fluid, etc. due to over heat.

So, avoid to keep this kind of condition when servicing as well as driving.

Trouble	Possible cause	Corrective action
Pressure hose burst	Excessive holding time of relief status	Instruct customers.
	Malfunction of relief valve	Replace oil pump.
	Poor cold characteristic of fluid	Replace fluid.
Forced out return hose	Poor connection	Correct.
	Poor holding of clip	Retighten.
	Poor cold characteristic of fluid	Replace fluid.
Fluid bleeding out of hose slightly	Wrong layout, tensioned	Replace hose.
	Excessive play of engine due to deterioration of engine mounting rubber	Replace defective parts.
	Improper stop position of pitching stopper	Replace defective parts.
Crack on hose	Excessive holding time of relief status	Replace. Instruct customer.
	Excessive tightening torque for return hose clip	Replace.
	Power steering fluid, brake fluid, engine oil, electrolyte adhere on the hose surface	Replace. Pay attention on service work.
	Too many times use in extremely cold weather	Replace. Instruct customers.

PIPE ASSEMBLY

Power Assisted System (Power Steering)

CAUTION:

It is likely that although one judges fluid leakage, there is actually no leakage. This is because the fluid spilt during the last maintenance was not completely wiped off. Be sure to wipe off spilt fluid thoroughly after maintenance.

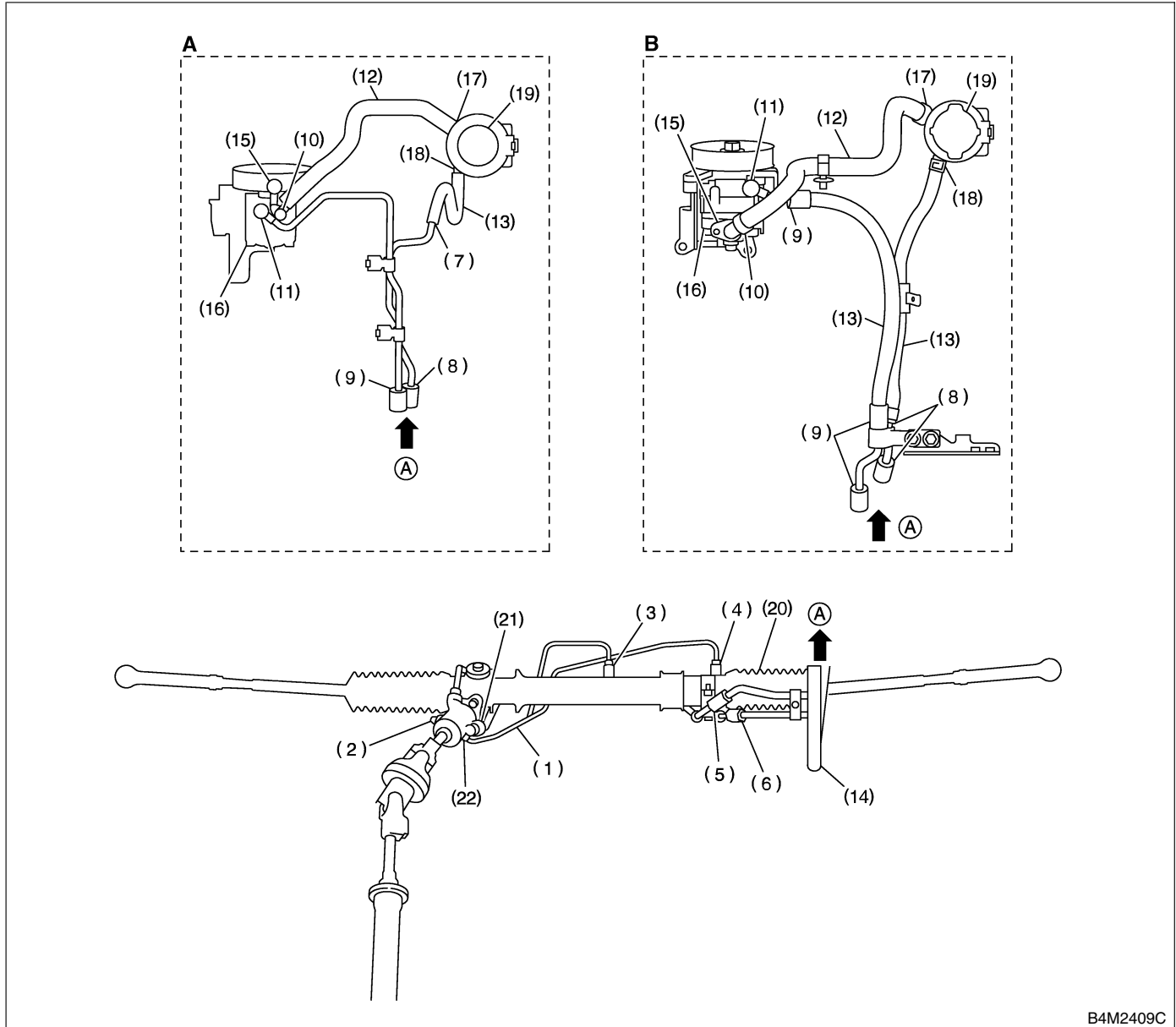

B4M2409C

(A) 2.5 l model

(B) 3.0 l model

PIPE ASSEMBLY

Power Assisted System (Power Steering)

Fluid leaking area	Possible cause	Corrective action
Leakage from connecting portions of pipes and hoses, numbered with (1) through (11) in figure	Insufficient tightening of flare nut, catching dirt or the like, damage to flare or flare nut or eye bolt	Loosen and retighten, if ineffective, replace.
	Poor insertion of hose, poor clamping	Retighten or replace clamp.
	Damaged O-ring or gasket	Replace O-ring or gasket pipe or hose with a new one, if ineffective, replace gearbox also.
Leakage from hose (12), (13) and (14) in figure	Crack or damage in hose	Replace with a new one.
	Crack or damage in hose hardware	Replace with a new one.
Leakage from surrounding of cast iron portion of oil pump (15) and (16) in figure	Damaged O-ring	Replace oil pump.
	Damaged gasket	Replace oil pump.
Leakage from oil tank (17) and (18) in figure	Crack in oil tank	Replace oil tank.
Leakage from filler neck (19)	Damaged cap packing	Replace cap.
	Crack in root of filler neck	Replace oil tank.
	High fluid level *1	Adjust fluid level.
Leakage from surrounding of power cylinder of gearbox (20) in figure	Damaged oil seal	Replace oil seal.
Leakage from control valve of gearbox (21) and (22) in figure	Damaged packing or oil seal	Replace problem parts.
	Damage in control valve	Replace control valve.

NOTE:

Fluid level is specified at optimum position (range) for ordinary use. Accordingly, if the vehicle is used often under hard conditions such as on very rough roads or in mountainous areas, fluid may bleed out from cap air vent hole. This is not a problem. If a customer complains strongly and is not likely to be satisfied with the leakage, lower the fluid level to the extent that fluid will not bleed out under the conditions described, and have the customer check the fluid level and its quality more frequently than usual.