

GENERAL DESCRIPTION

Front Suspension

1. General Description S202001

A: SPECIFICATIONS S202001E49

1. STABILIZER S202001E4901

Model	Bar dia.
Except OUTBACK	20 mm (0.79 in)
OUTBACK	21 mm (0.83 in)

2. WHEEL ALIGNMENT S202001E4902

Model	Sedan	Wagon	OUTBACK
Camber (tolerance: $\pm 0^{\circ}30'$)	$-0^{\circ}05'$	$-0^{\circ}05'$	$0^{\circ}20'$
Caster (common difference: $\pm 0^{\circ}45'$)	$3^{\circ}05'$	$2^{\circ}50'$	$2^{\circ}40'$
Toe-in	0 \pm 3 mm (0 \pm 0.12 in) Each toe angle: $\pm 0^{\circ}15'$		
Kingpin angle	$14^{\circ}15'$	$14^{\circ}15'$	$13^{\circ}30'$
Wheel arch height [tolerance: $+^{12}/_{-24}$ mm ($+^{0.47}/_{-0.94}$ in)]	388 mm (15.28 in)	388 mm (15.28 in)	424 mm (16.69 in)

NOTE:

- Front and rear toe-ins and front camber can be adjusted. If toe-in or camber tolerance exceeds specifications, adjust toe-in and camber to the middle value of specification.
- The other items indicated in the specification table cannot be adjusted. If the other items exceeds specifications, check suspension parts and connections for deformities; replace with new ones as required.

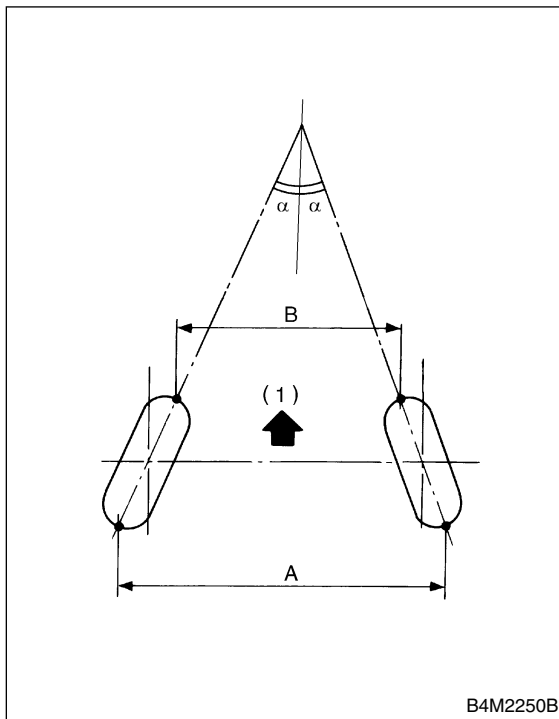

(1) Front

A - B = Positive: Toe-in, Negative: Toe-out

α = Each toe angle

B: COMPONENT

S202001A05

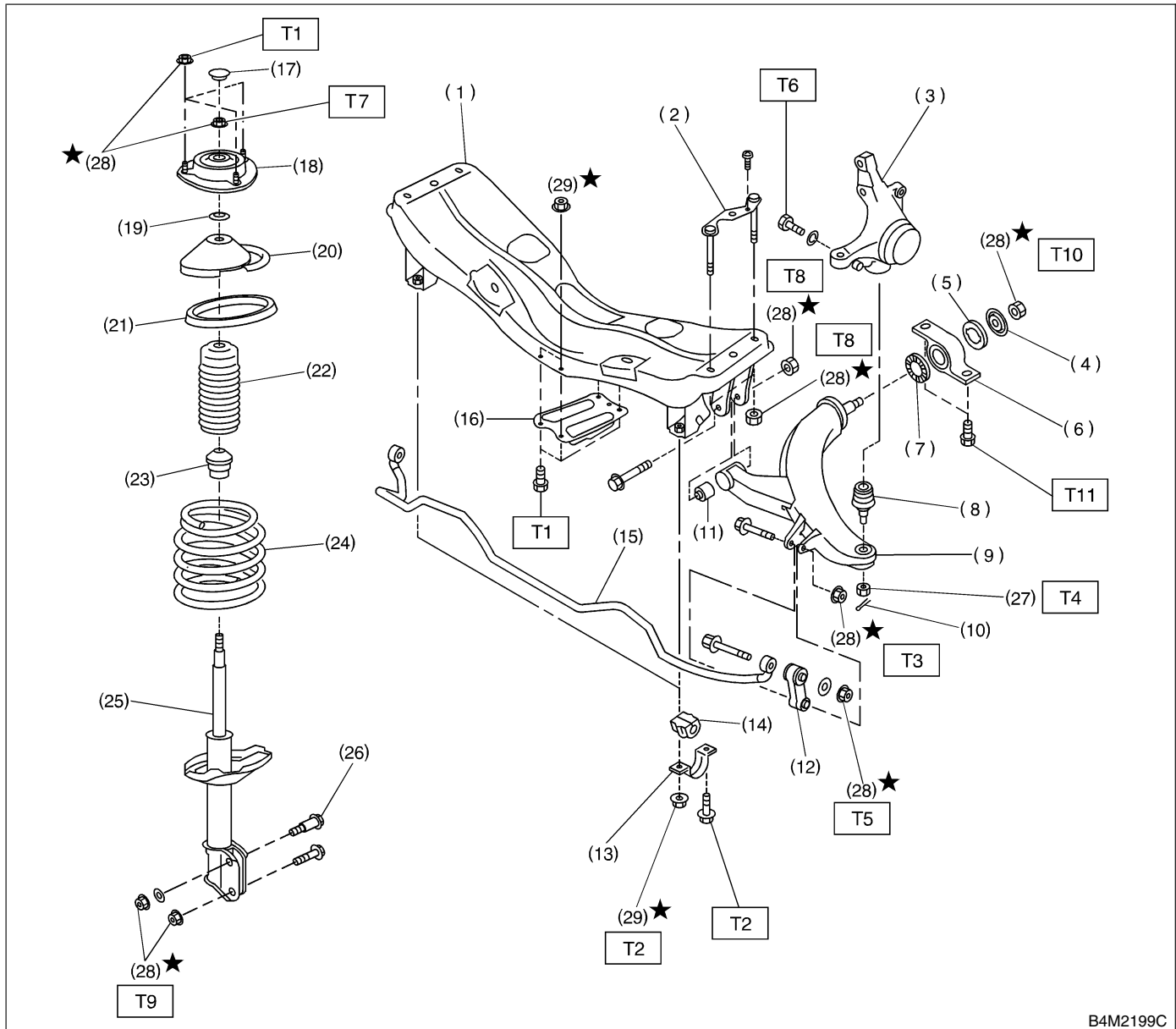

B4M2199C

- | | |
|----------------------------|------------------------|
| (1) Front crossmember | (16) Jack-up plate |
| (2) Bolt ASSY | (17) Dust seal |
| (3) Housing | (18) Strut mount |
| (4) Washer | (19) Spacer |
| (5) Stopper rubber (Rear) | (20) Upper spring seat |
| (6) Rear bushing | (21) Rubber seat |
| (7) Stopper rubber (Front) | (22) Dust cover |
| (8) Ball joint | (23) Helper |
| (9) Transverse link | (24) Coil spring |
| (10) Cotter pin | (25) Damper strut |
| (11) Front bushing | (26) Adjusting bolt |
| (12) Stabilizer link | (27) Castle nut |
| (13) Clamp | (28) Self-locking nut |
| (14) Bushing | (29) Flange nut |
| (15) Stabilizer | |

Tightening torque: N·m (kgf-m, ft-lb)

- | |
|-----------------------------|
| T1: 20 (2.0, 14.5) |
| T2: 25 (2.5, 18.1) |
| T3: 30 (3.1, 22) |
| T4: 39 (4, 29) |
| T5: 45 (4.6, 33) |
| T6: 50 (5.1, 37) |
| T7: 54 (5.5, 39.8) |
| T8: 100 (10.2, 74) |
| T9: 152 (16, 116) |
| T10: 186 (19.0, 137) |
| T11: 245 (25.0, 181) |

C: CAUTION S202001A03

- Wear working clothing, including a cap, protective goggles, and protective shoes during operation.
- Remove contamination including dirt and corrosion before removal, installation or disassembly.
- Keep the disassembled parts in order and protect them from dust or dirt.
- Before removal, installation or disassembly, be sure to clarify the failure. Avoid unnecessary removal, installation, disassembly, and replacement.
- Use SUBARU genuine grease etc. or the equivalent. Do not mix grease etc. with that of another grade or from other manufacturers.
- Be sure to tighten fasteners including bolts and nuts to the specified torque.
- Place shop jacks or safety stands at the specified points.
- Apply grease onto sliding or revolution surfaces before installation.
- Before installing O-rings or snap rings, apply sufficient amount of grease to avoid damage and deformation.
- Before securing a part on a vise, place cushioning material such as wood blocks, aluminum plate, or shop cloth between the part and the vise.

D: PREPARATION TOOL S202001A17

1. SPECIAL TOOLS S202001A1701

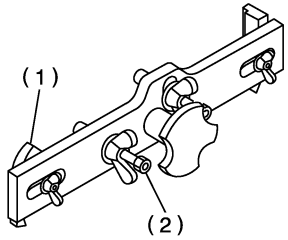
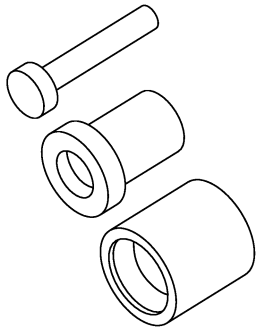
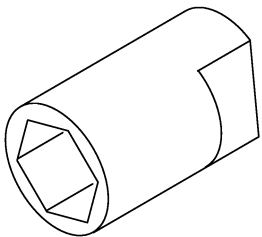
ILLUSTRATION	TOOL NUMBER	DESCRIPTION	REMARKS
 <p>B4M2378A</p>	927380002	ADAPTER	Used as an adapter for camber & caster gauge when measuring camber and caster. (1) 28199AC000 PLATE (2) 28199AC010 BOLT
 <p>B4M2385</p>	927680000	INSTALLER & REMOVER	Used for replacing transverse link bushing.
 <p>B4M2384</p>	927760000	STRUT MOUNT SOCKET	Used for disassembling and assembling strut and shock mount.

2. GENERAL PURPOSE TOOLS S202001A1702

TOOL NAME	REMARKS
Alignment gauge	Used for wheel alignment measurement.
Turning radius gauge	Used for wheel alignment measurement.
Toe-in gauge	Used for toe-in measurement.
Dial gauge	Used for damper strut measurement.

WHEEL ALIGNMENT

Front Suspension

2. Wheel Alignment S202116

A: INSPECTION S202116A10

Check the following items before taking wheel alignment measurement.

Check items before taking wheel alignment measurement:

- tire air pressure
- unbalanced right and left tire wear, size difference
- tire run-out
- ball joint excessive play, wear
- tie rod end excessive play, wear
- wheel bearing excessive play
- right and left wheel base imbalance
- steering link part deformed, excessive play
- suspension part deformed, excessive play

Check, adjust and/or measure wheel alignment in accordance with procedures indicated in figure:

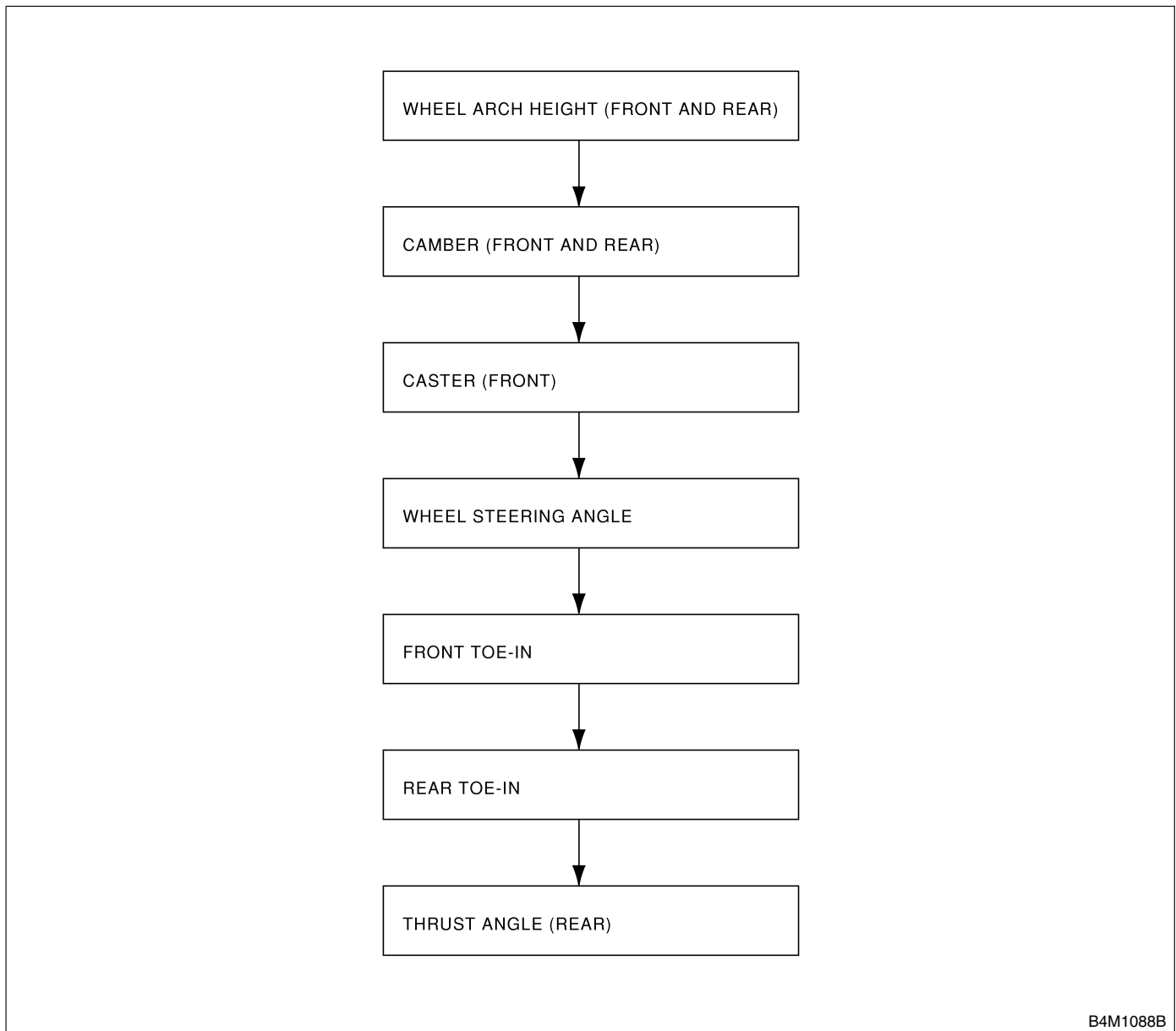

B4M1088B

WHEEL ALIGNMENT

Front Suspension

1. WHEEL ARCH HEIGHT S202116A1006

- 1) Set vehicle on a level surface.
- 2) Set vehicle under “curb weight” conditions. (Empty luggage compartment, install spare tire, jack, service tools, and top up fuel tank.)
- 3) Set steering wheel in a straight line, then move the vehicle straight ahead more than 5 m (16 ft) to settle the suspension.
- 4) Suspend thread from wheel arch (point “A” in figure below) to determine a point directly above center of wheel.
- 5) Measure distance between measuring point “A” and center of wheel.

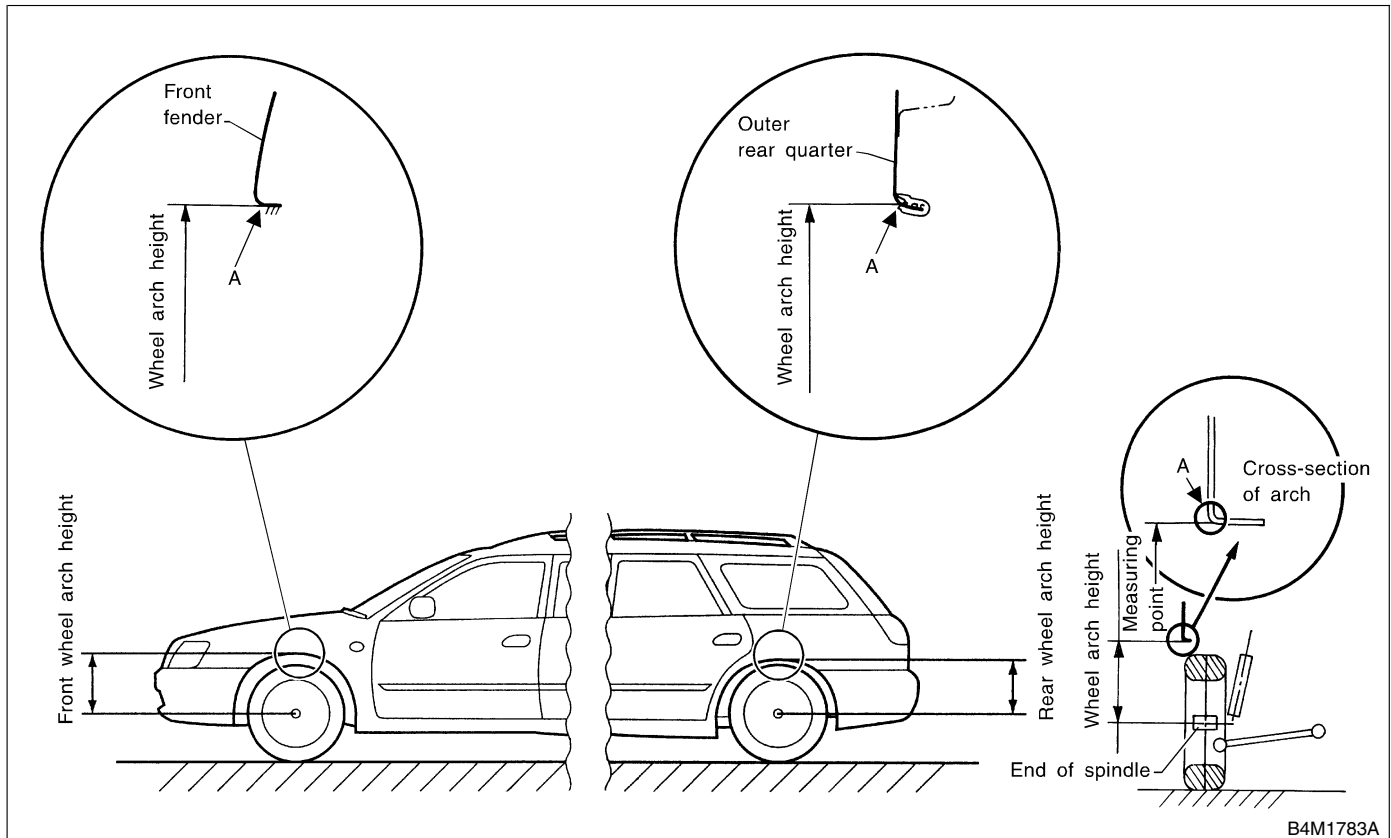

B4M1783A

Model	Specified wheel arch height
Sedan	388^{+12}_{-24} mm ($15.28^{+0.47}_{-0.94}$ in)
Wagon	388^{+12}_{-24} mm ($15.28^{+0.47}_{-0.94}$ in)
OUTBACK	424^{+12}_{-24} mm ($16.69^{+0.47}_{-0.94}$ in)

WHEEL ALIGNMENT

Front Suspension

2. CAMBER S202116A1002

● Inspection

1) Place front wheel on turning radius gauge. Make sure ground contacting surfaces of front and rear wheels are set at the same height.

2) Set ST into the center of the wheel, and then install the wheel alignment gauge.

ST 927380002 ADAPTER

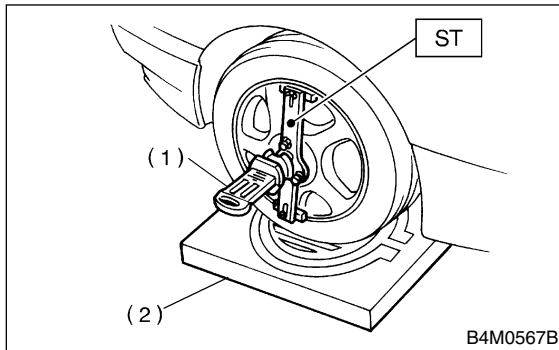

- (1) Alignment gauge
- (2) Turning radius gauge

3) Follow the wheel alignment gauge operation manual to measure the camber angle.

NOTE:

Refer to the "SPECIFICATIONS" for the camber values.

Front: <Ref. to FS-2, SPECIFICATIONS, General Description.>

Rear: <Ref. to RS-2, SPECIFICATIONS, General Description.>

● Front Camber Adjustment

1) Loosen two self-locking nuts located at lower front portion of strut.

CAUTION:

● When adjusting bolt needs to be loosened or tightened, hold its head with a wrench and turn self-locking nut.

● Discard loosened self-locking nut and replace with a new one.

2) Turn camber adjusting bolt so that camber is set at the specification.

NOTE:

Moving the adjusting bolt by one scale graduation changes camber by approximately $0^{\circ}10'$.

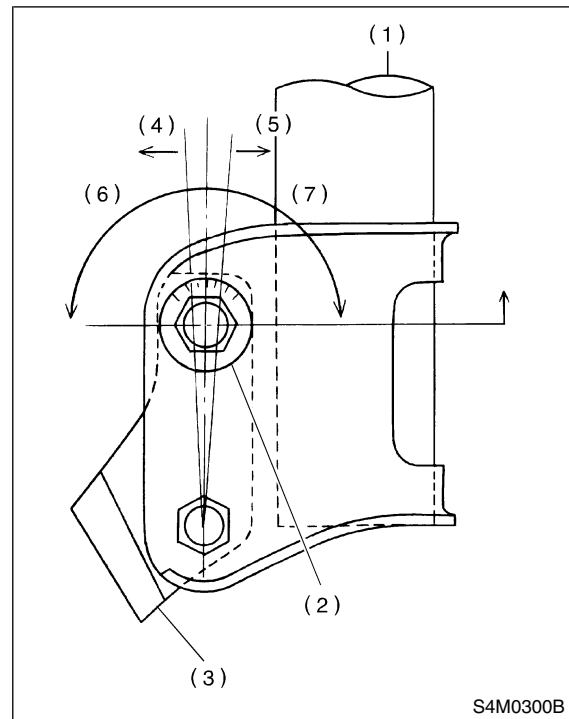

- (1) Strut
- (2) Adjusting bolt
- (3) Housing
- (4) Outer
- (5) Inner
- (6) Camber is increased.
- (7) Camber is decreased.

WHEEL ALIGNMENT

Front Suspension

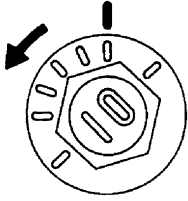
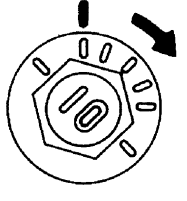
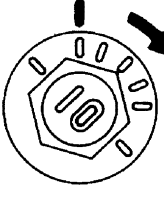
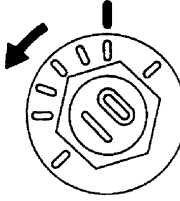
	Left side	Right side
Camber is increased.	 <p>Rotate counterclockwise.</p> <p>B4M0190</p>	 <p>Rotate clockwise.</p> <p>B4M0350</p>
Camber is decreased.	 <p>Rotate clockwise.</p> <p>B4M0350</p>	 <p>Rotate counterclockwise.</p> <p>B4M0190</p>

3) Tighten the two self-locking nuts.

Tightening torque:

152 N·m (16 kgf-m, 116 ft-lb)

3. CASTER S202116A1003

● Inspection

- 1) Place front wheel on turning radius gauge. Make sure ground contacting surfaces of front and rear wheels are set at the same height.
 - 2) Set ST into the center of the wheel, and then install the wheel alignment gauge.
- ST 927380002 ADAPTER

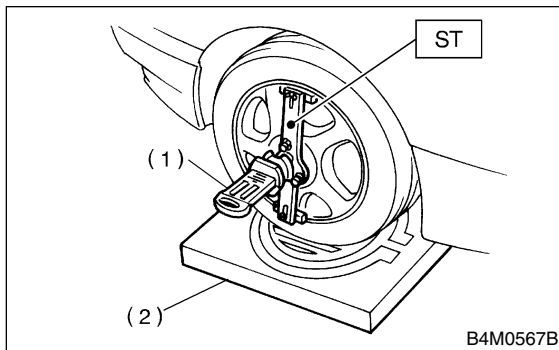

- (1) Alignment gauge
(2) Turning radius gauge

3) Follow the wheel alignment gauge operation manual to measure the caster angle.

NOTE:

Refer to the "SPECIFICATIONS" for the caster values. <Ref. to FS-2, SPECIFICATIONS, General Description.>

4. STEERING ANGLE S202116A1005

● Inspection

- 1) Place vehicle on a turning radius gauge.
- 2) While depressing brake pedal, turn steering wheel fully to the left and right. With steering wheel held at each fully turned position, measure both the inner and outer wheel steering angle.

Steering angle:

Model	Except OUTBACK	OUTBACK
Inner wheel	$36.3^{\circ} \pm 1.5^{\circ}$	$34.5^{\circ} \pm 1.5^{\circ}$
Outer wheel	$31.6^{\circ} \pm 1.5^{\circ}$	$30.3^{\circ} \pm 1.5^{\circ}$

● Adjustment

Turn tie-rod to adjust steering angle of both inner and outer wheels.

CAUTION:

- Check toe-in.
- Correct boot if it is twisted.

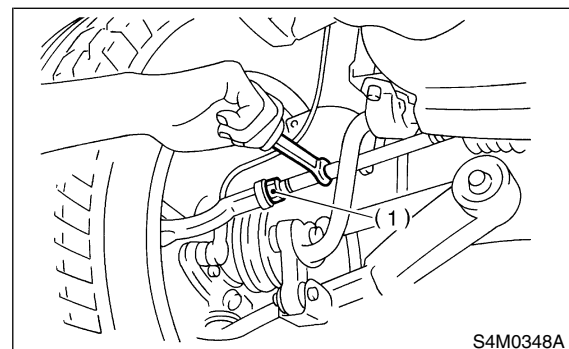

- (1) Lock nut

WHEEL ALIGNMENT

Front Suspension

5. FRONT WHEEL TOE-IN S202116A1004

● Inspection

- 1) Using a toe gauge, measure front wheel toe-in.

Toe-in:

$0 \pm 3 \text{ mm } (0 \pm 0.12 \text{ in})$

- 2) Mark rear sides of left and right tires at height corresponding to center of spindles and measure distance "A" between marks.
- 3) Move vehicle forward so that marks line up with front sides at height corresponding to center of spindles.
- 4) Measure distance "B" between left and right marks. Toe-in can then be obtained by the following equation:

$$A - B = \text{Toe-in}$$

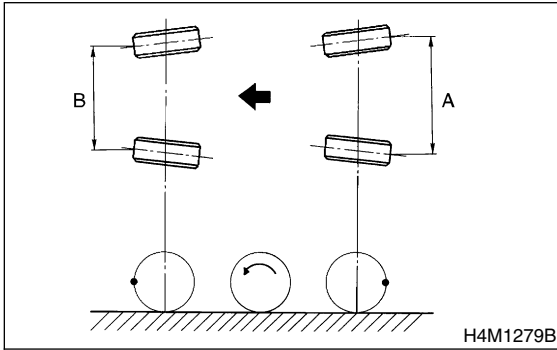

● Adjustment

- 1) Loosen the left and right side steering tie-rod lock nuts.
- 2) Turn the left and right tie rods equal amounts until the toe-in is at the specification. Both the left and right tie-rod are right-hand threaded. To increase toe-in, turn both tie-rod clockwise equal amounts (as viewed from the inside of the vehicle).

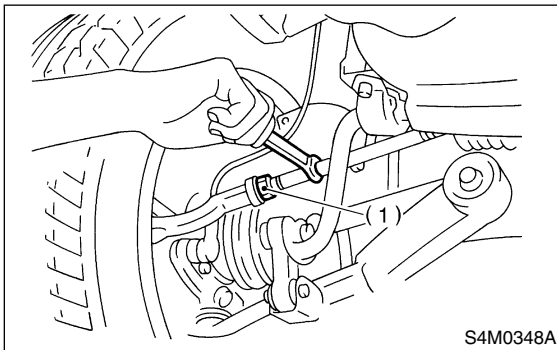

(1) Lock nut

- 3) Tighten tie-rod lock nut.

Tightening torque:

$83 \text{ N}\cdot\text{m } (8.5 \text{ kgf}\cdot\text{m}, 61.5 \text{ ft}\cdot\text{lb})$

CAUTION:

Correct tie-rod boot, if it is twisted.

NOTE:

Check the left and right wheel steering angle is within specifications.

6. REAR WHEEL TOE-IN S202116A1007

● Inspection

- 1) Using a toe-in gauge, measure rear wheel toe-in.

Toe-in:

$0 \pm 3 \text{ mm } (0 \pm 0.12 \text{ in})$

- 2) Mark rear sides of left and right tires at height corresponding to center of spindles and measure distance "A" between marks.
- 3) Move vehicle forward so that marks line up with front sides at height corresponding to center of spindles.
- 4) Measure distance "B" between left and right marks. Toe-in can then be obtained by the following equation:

$$A - B = \text{Toe-in}$$

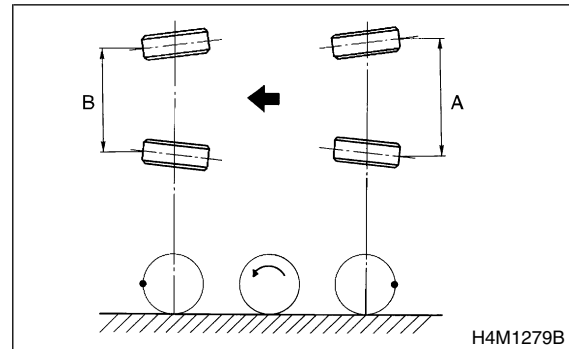

WHEEL ALIGNMENT

Front Suspension

● Adjustment

1) Loosen self-locking nut on inner side of link rear.

2) Turn adjusting bolt head until toe-in is at the specification.

CAUTION:

- When loosening or tightening adjusting bolt, hold bolt head and turn self-locking nut.
- Discard loosened self-locking nut and replace with a new one.

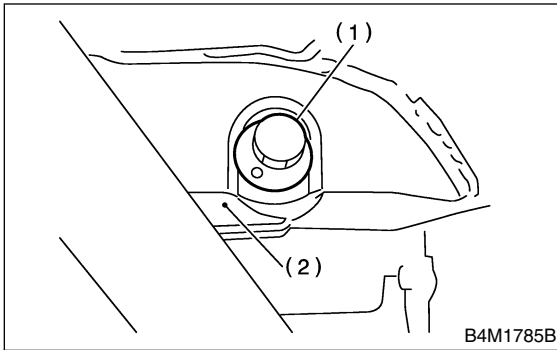

- (1) Adjusting bolt
(2) Link rear

NOTE:

When left and right wheels are adjusted for toe-in at the same time, the movement of one scale graduation changes toe-in by approximately 3 mm (0.12 in).

	Left side	Right side
Toe-in is increased.	<p>Rotate clockwise.</p> <p>B4M1787</p>	<p>Rotate counterclockwise.</p> <p>B4M1786</p>
Toe-in is decreased.	<p>Rotate counterclockwise.</p> <p>B4M1786</p>	<p>Rotate clockwise.</p> <p>B4M1787</p>

3) Tighten self-locking nut.

Tightening torque:

120 N·m (12.2 kgf·m, 88 ft·lb)

WHEEL ALIGNMENT

Front Suspension

7. THRUST ANGLE S202116A1008

● Inspection

- 1) Position vehicle on a level surface.
- 2) Move vehicle 3 to 4 meters directly forward.
- 3) Determine locus of both front and rear axles.
- 4) Measure distance "L" between center line of loci of the axles.

Thrust angle:

Less than 30' when "L" is equal to or less than 23 mm (0.91 in).

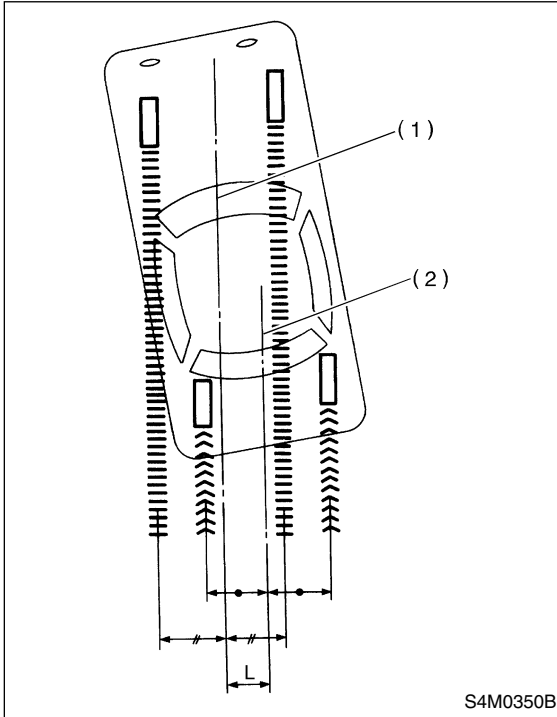

- (1) Center line of loci (front axle)
- (2) Center line of loci (rear axle)

● Adjustment

- 1) Make thrust angle adjustments by turning toe-in adjusting bolts of rear suspension equally in the same direction.
- 2) When one rear wheel is adjusted in a toe-in direction, adjust the other rear wheel equally in toe-out direction, in order to make thrust angle adjustment.

- 3) When left and right adjusting bolts are turned incrementally by one graduation in the same direction, the thrust angle will change approximately 10' ["L" is almost equal to 7.5 mm (0.295 in)].

Thrust angle:
0°±30'

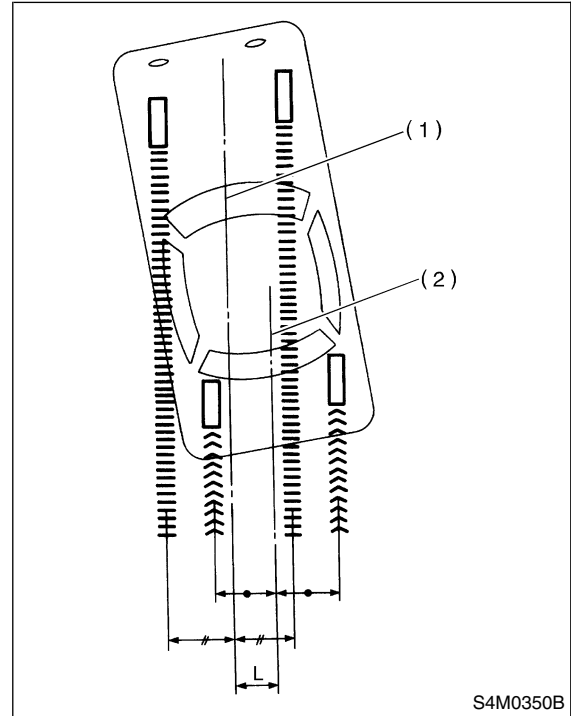

- (1) Center line of loci (front axle)
- (2) Center line of loci (rear axle)

NOTE:

Thrust angle refers to a mean value of left and right rear wheel toe angles in relation to vehicle body center line. Vehicle is driven straight in the thrust angle direction while swinging in the oblique direction depending on the degree of the mean thrust angle.

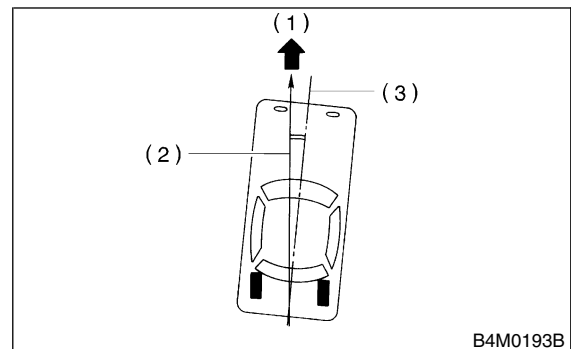

- (1) Front
- (2) Thrust angle
- (3) Body center line

Thrust angle: $r = (\alpha - \beta)/2$

α : Right rear wheel toe-in angle

β : Left rear wheel toe-in angle

NOTE:

Here, use only positive toe-in values from each wheel to substitute for α and β in the equation.

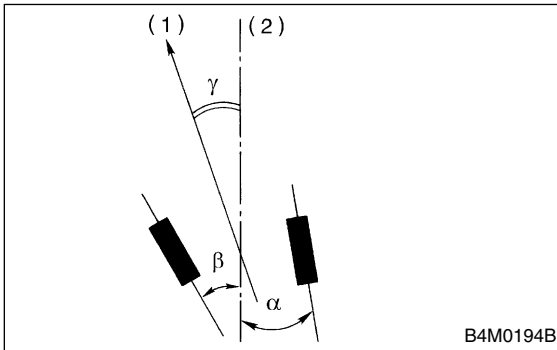

(1) Front

(2) Body center line

FRONT TRANSVERSE LINK

Front Suspension

3. Front Transverse Link S202113

A: REMOVAL S202113A18

- 1) Set vehicle on a lift.
- 2) Disconnect ground cable from battery.
- 3) Lift-up the vehicle and remove the wheel.
- 4) Disconnect stabilizer link from transverse link.
- 5) Remove bolt securing ball joint of transverse link to housing.

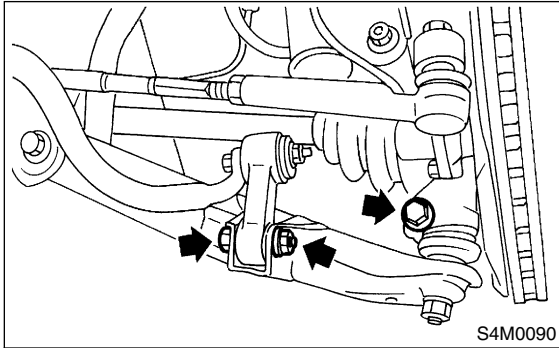

- 6) Remove nut (do not remove bolt) securing transverse link to crossmember.
- 7) Remove two bolts securing bushing bracket of transverse link to vehicle body at rear bushing location.

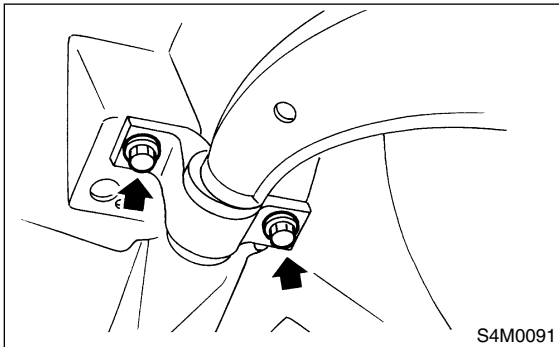

- 8) Extract ball joint from housing.
- 9) Remove bolt securing transverse link to crossmember and extract transverse link from crossmember.

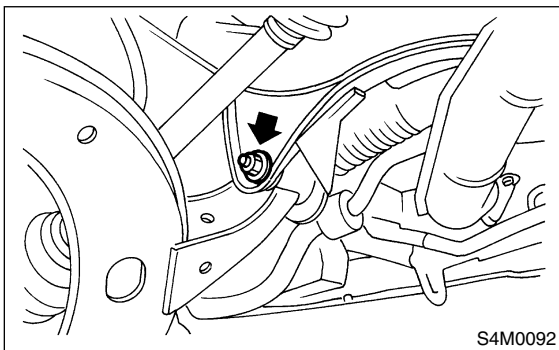

B: INSTALLATION S202113A11

- 1) Temporarily tighten the two bolts used to secure rear bushing of the transverse link to body.

NOTE:

These bolts should be tightened to such an extent that they can still move back and forth in the oblong shaped hole in the bracket (which holds the bushing).

- 2) Install bolts used to connect transverse link to crossmember and temporarily tighten with nut.

CAUTION:

Discard loosened self-locking nut and replace with a new one.

- 3) Insert ball joint into housing.
- 4) Connect stabilizer link to transverse link, and temporarily tighten bolts.

CAUTION:

Discard loosened self-locking nut and replace with a new one.

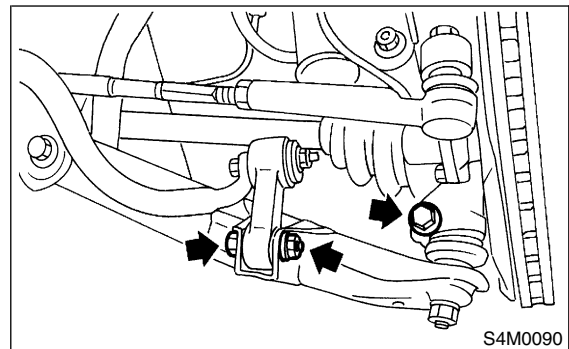

- 5) Tighten the following points in the order shown below when wheels are in full contact with the ground and vehicle is curb weight.

- (1) Transverse link and stabilizer

Tightening torque:

30 N·m (3.1 kgf-m, 22 ft-lb)

- (2) Transverse link and crossmember

Tightening torque:

100 N·m (10.2 kgf-m, 74 ft-lb)

- (3) Transverse link rear bushing and body

Tightening torque:

245 N·m (25 kgf-m, 181 ft-lb)

NOTE:

- Move rear bushing back and forth until transverse link-to-rear bushing clearance is established (as indicated in figure) before tightening.
- Check wheel alignment and adjust if necessary.

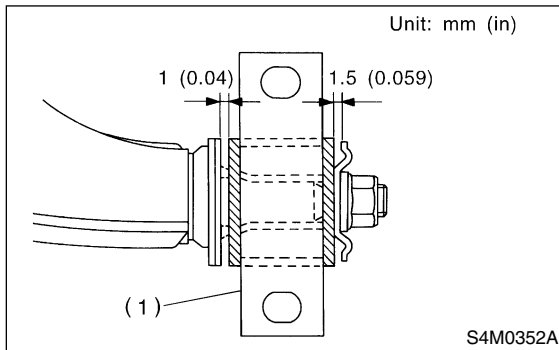

(1) Rear bushing

C: DISASSEMBLY

S202113A06

1. FRONT BUSHING

S202113A0601

Using ST, press front bushing out of place.
ST 927680000 INSTALLER & REMOVER SET

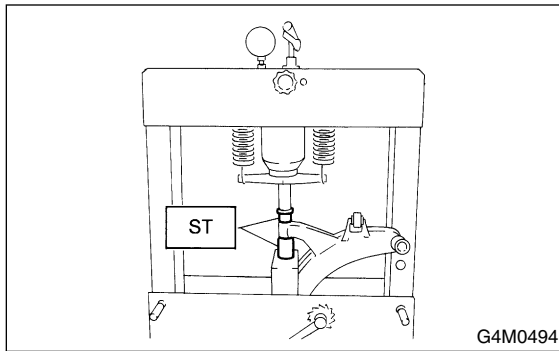

2. REAR BUSHING

S202113A0602

- 1) Scribe an aligning mark on transverse link and rear bushing.
- 2) Loosen nut and remove rear bushing.

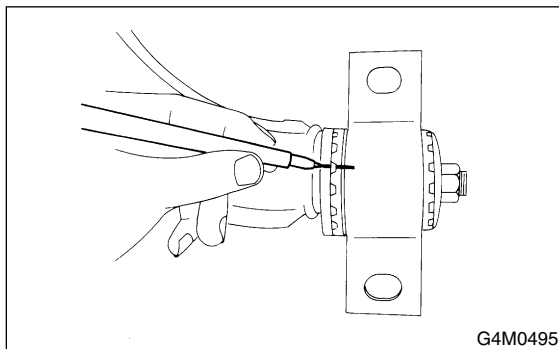

D: ASSEMBLY

S202113A02

1. FRONT BUSHING

S202113A0201

To reassemble, reverse disassembly procedures.

CAUTION:

Install front bushing in correct direction, as shown in figure.

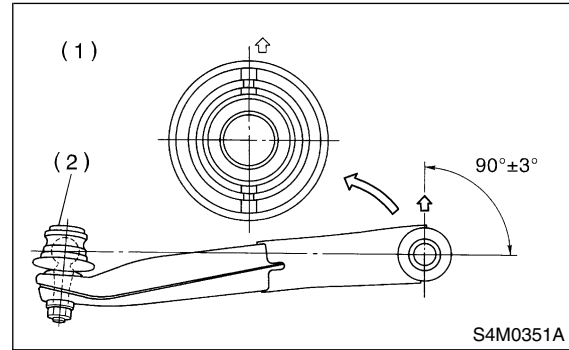

- (1) Face bushing toward center of ball joint
- (2) Ball joint

2. REAR BUSHING

S202113A0202

- 1) Install rear bushing to transverse link and align aligning marks scribed on the two.
- 2) Tighten self-locking nut.

CAUTION:

- Discard loosened self-locking nut and replace with a new one.
- While holding rear bushing so as not to change position of aligning marks, tighten self-locking nut.

Tightening torque:

186 N·m (19.0 kgf·m, 137 ft·lb)

E: INSPECTION

S202113A10

- 1) Check transverse link for wear, damage and cracks, and correct or replace if defective.
- 2) Check bushings for cracks, fatigue or damage.
- 3) Check rear bushing for oil leaks.

FRONT BALL JOINT

Front Suspension

4. Front Ball Joint S202114

A: REMOVAL S202114A18

- 1) Set vehicle on a lift.
- 2) Disconnect ground cable from battery.
- 3) Lift-up the vehicle and remove the wheel.
- 4) Pull out the cotter pin from the ball stud, remove the castle nut, and extract the ball stud from the transverse link.
- 5) Remove the bolt securing the ball joint to the housing.

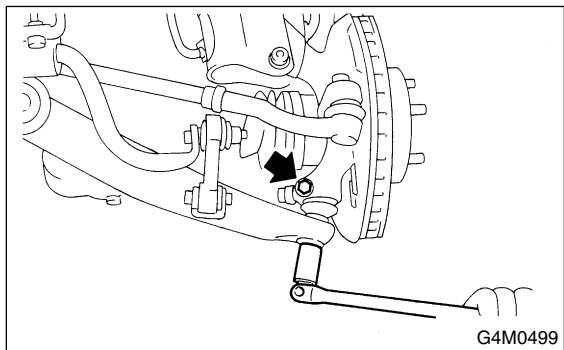

- 6) Extract the ball joint from the housing.

B: INSTALLATION S202114A11

- 1) Install ball joint onto housing.

Torque (Bolt):

50 N·m (5.1 kgf-m, 37 ft-lb)

CAUTION:

Do not apply grease to tapered portion of ball stud.

- 2) Connect ball joint to transverse link.

Torque (Castle nut):

39 N·m (4.0 kgf-m, 29 ft-lb)

- 3) Retighten castle nut further within 60° until a slot in castle nut is aligned with the hole in ball stud end, then insert new cotter pin and bend it around castle nut.
- 4) Install front wheel.

C: INSPECTION S202114A10

- 1) Measure play of ball joint by the following procedures. Replace with a new one when the play exceeds the specified value.

- (1) With 686 N (70 kgf, 154 lb) loaded in the direction shown in the figure, measure dimension l_1 .

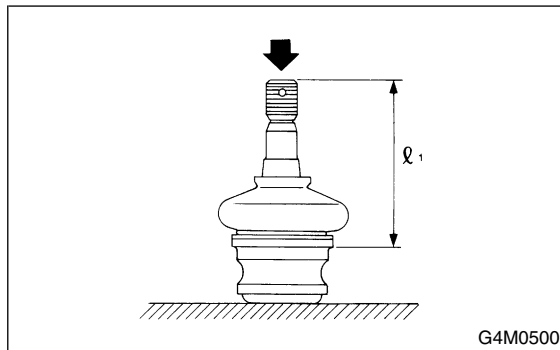

- (2) With 686 N (70 kgf, 154 lb) loaded in the opposite direction shown in the figure, measure dimension l_2 .

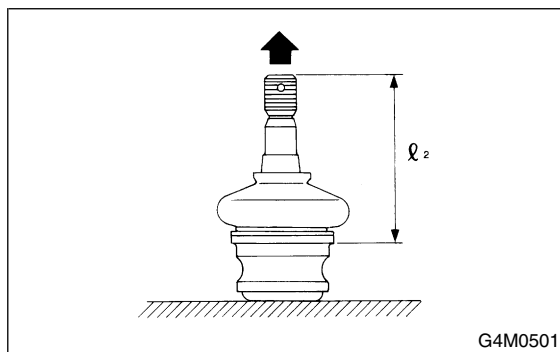

- (3) Calculate plays from the following formula.

$$S = l_2 - l_1$$

- (4) When plays are larger than the following value, replace with a new one.

FRONT BALL JOINT

**Specified play for replacement: S
Less than 0.3 mm (0.012 in)**

- 2) When play is smaller than the specified value, visually inspect the dust cover.
- 3) The ball joint and cover that have been removed must be checked for wear, damage or cracks, and any defective part must be replaced.
- 4) If the dust cover is damaged, replace with the new ball joint.

5. Front Strut S202115

A: REMOVAL S202115A18

- 1) Set vehicle on a lift.
- 2) Disconnect ground cable from battery.
- 3) Lift-up the vehicle and remove the wheel.
- 4) Remove bolt securing brake hose from strut.

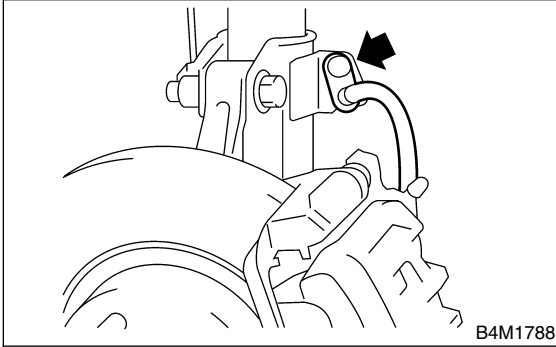

- 5) Scribe an alignment mark on the camber adjusting bolt which secures strut to housing.
- 6) Remove bolt securing the ABS sensor harness.

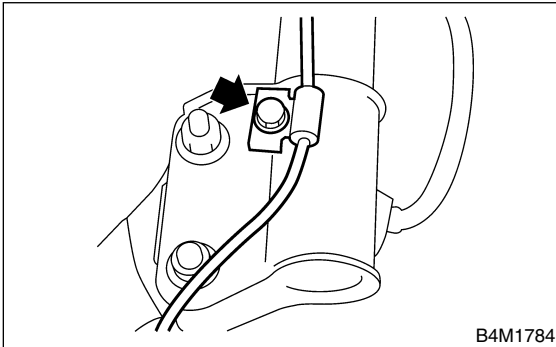

- 7) Remove two bolts securing housing to strut.

CAUTION:
While holding head of adjusting bolt, loosen self-locking nut.

- 8) Remove the three nuts securing strut mount to body.

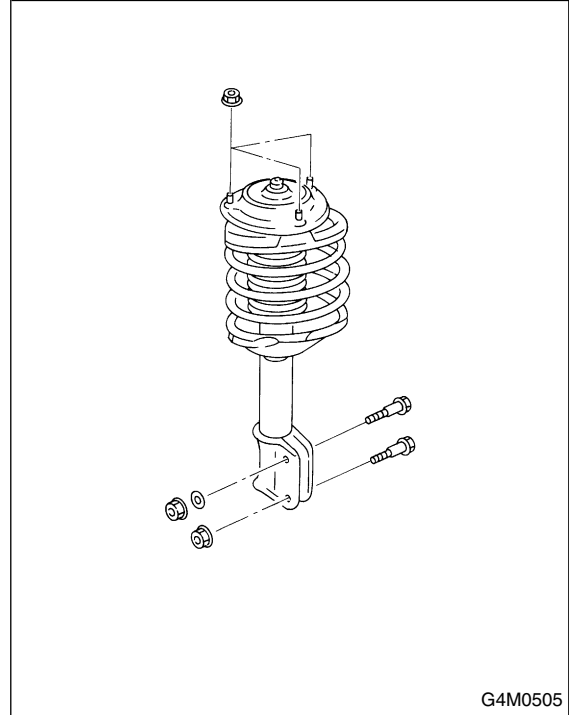

FRONT STRUT

Front Suspension

B: INSTALLATION S202115A11

- 1) Install strut mount at upper side of strut to body and tighten with nuts.

Tightening torque:
20 N·m (2.0 kgf-m, 14.5 ft-lb)

- 2) Position aligning mark on camber adjustment bolt with aligning mark on lower side of strut.

CAUTION:

- While holding head of adjusting bolt, tighten self-locking nut.
- Be sure to use new self-locking nut.

Tightening torque:
152 N·m (16 kgf-m, 116 ft-lb)

- 3) Install ABS sensor harness to strut.

Tightening torque:
32 N·m (3.3 kgf-m, 23.9 ft-lb)

- 4) Install bolts which secure brake hose to strut.

Tightening torque:
32 N·m (3.3 kgf-m, 23.9 ft-lb)

- 5) Install wheels.

NOTE:

Check wheel alignment and adjust if necessary.

C: DISASSEMBLY S202115A06

- 1) Using a coil spring compressor, compress coil spring.

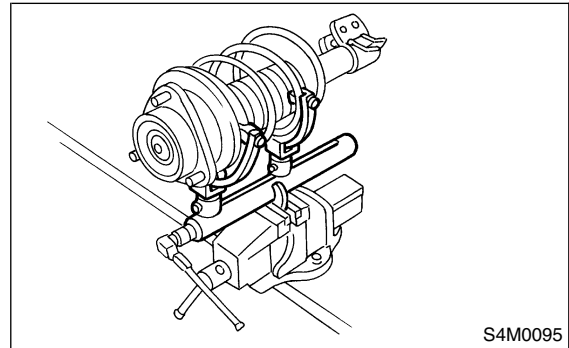

- 2) Using ST, remove self-locking nut.
ST 927760000 STRUT MOUNT SOCKET

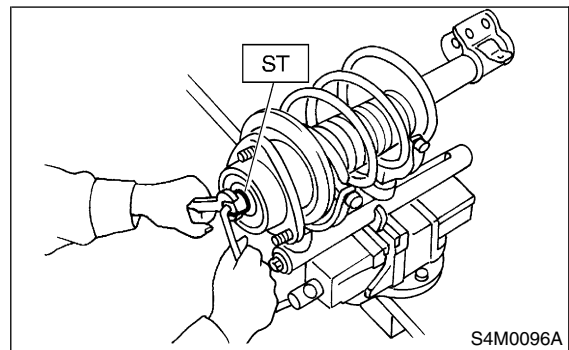

- 3) Remove strut mount, upper spring seat and rubber seat from strut.
- 4) Gradually decreasing compression force, and remove coil spring.
- 5) Remove dust cover and helper spring.

D: ASSEMBLY S202115A02

1) Before installing coil spring, strut mount, etc., on the strut, check for the presence of air in the dampening force generating mechanism of the strut since air prevents proper dampening force from being produced.

2) Checking for the presence of air

(1) Place the strut vertically with the piston rod facing up.

(2) Move the piston rod to the center of its entire stroke.

(3) While holding the piston rod end with fingertips, move the rod up and down.

(4) If the piston rod moves at least 10 mm (0.39 in) in the former step, purge air from the strut.

3) Air purging procedure

(1) Place the strut vertically with the piston rod facing up.

(2) Fully extend the piston rod.

(3) With the piston rod fully extended, place the piston rod side down. The strut must stand vertically.

(4) Fully contract the piston rod.

(5) Repeat 3 or 4 times from the first step.

NOTE:

After completely purging air from the strut, be sure to place the strut with the piston rod facing up. If it is laid down, check for entry of air in the strut as outlined under "Checking for the presence of air".

4) Using a coil spring compressor, compress the coil spring.

NOTE:

Make sure that the vertical installing direction of coil spring is as shown in figure.

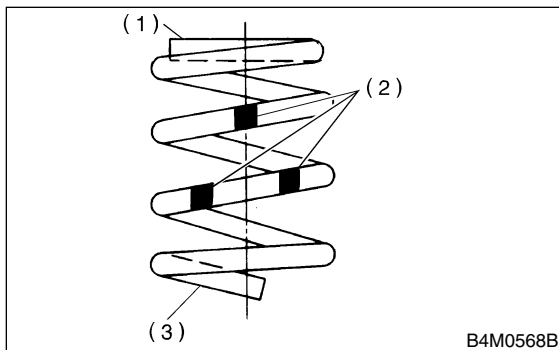

- (1) Flat (top side)
- (2) Identification paint
- (3) Inclined (bottom side)

5) Set the coil spring correctly so that its end face (1) fits well into the spring seat as shown in the figure.

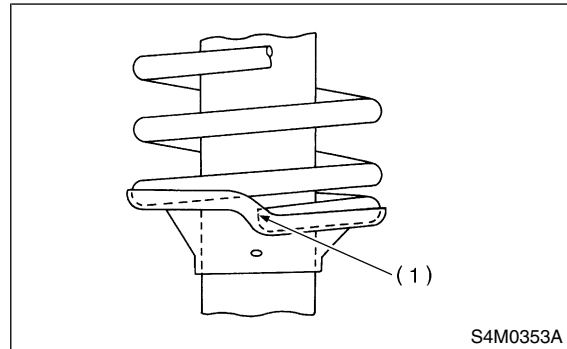

6) Install helper and dust cover to the piston rod.
7) Pull the piston rod fully upward, and install rubber seat and upper spring seat.

NOTE:

Ensure that upper spring seat is positioned as shown in figure.

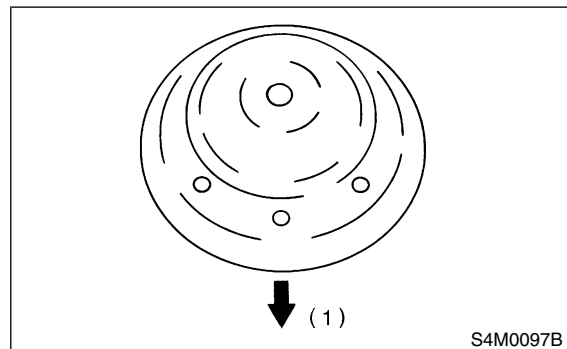

- (1) Outside of body

8) Install strut mount to the piston rod, and tighten the self-locking nut temporarily.

CAUTION:

Be sure to use a new self-locking nut.

9) Using hexagon wrench to prevent strut rod from turning, tighten self-locking nut with ST.

ST 927760000 STRUT MOUNT SOCKET

Tightening torque:

54 N·m (5.5 kgf·m, 39.8 ft·lb)

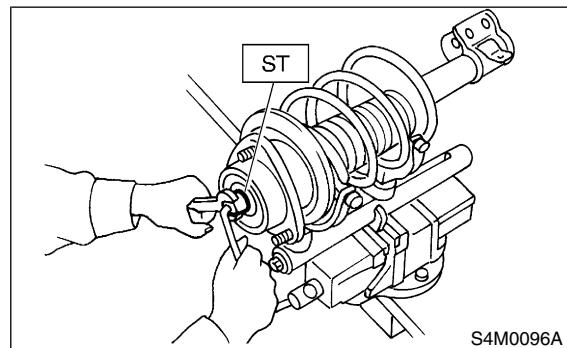

FRONT STRUT

Front Suspension

10) Loosen the coil spring carefully.

E: INSPECTION S202115A10

Check the disassembled parts for cracks, damage and wear, and replace with new parts if defective.

1. DAMPER STRUT S202115A1001

- 1) Check for oil leakage.
- 2) Move the piston rod up and down to check it operates smoothly without any binding.
- 3) Play of piston rod

● Measure the play as follows:

Fix outer shell and fully extend the rod. Set a dial gauge at the end of the rod: L [10 mm (0.39 in)], then apply a force of W [20 N (2 kgf, 4 lb)] to threaded portion. With the force of 20 N (2 kgf, 4 lb) applied, read dial gauge indication: P_1 . Apply a force of 20 N (2 kgf, 4 lb) in the opposite direction of "W", then read dial gauge indication: P_2 .

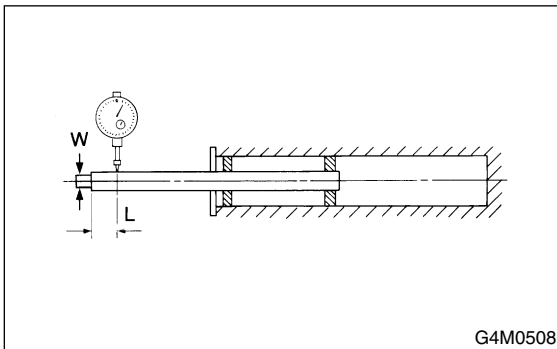

The free play is determined by the following equation:

$$\text{Play} = P_1, P_2$$

Limit of play:

Less than 0.8 mm (0.031 in)

If the play is greater, replace the strut.

2. STRUT MOUNT S202115A1002

Check rubber part for creep, cracks and deterioration, and replace it with a new one if defective.

3. DUST COVER S202115A1003

If any cracks or damage are found, replace it with a new one.

4. COIL SPRING S202115A1004

One having permanent strain should be replaced with a new one. When vehicle posture is uneven, although there are no considerable reasons like tire puncture, uneven loading, etc., check coil spring for its free length referring to specifications, cracks, etc., and replace it with a new one if defective.

5. HELPER S202115A1005

Replace it with a new one if cracked or damaged.

F: DISPOSAL S202115A07

CAUTION:

- Do not disassemble the strut damper or place it into a fire.
- Drill a hole before disposal of strut.
- Before handling gas filled struts, be sure to wear goggles to protect eyes from gas, oil and/or filings.

- 1) Place the gas filled strut on a flat and level surface with piston rod fully extended.
- 2) Using a 2 to 3 mm (0.08 to 0.12 in) dia. drill, make a hole in area shown in the figure.

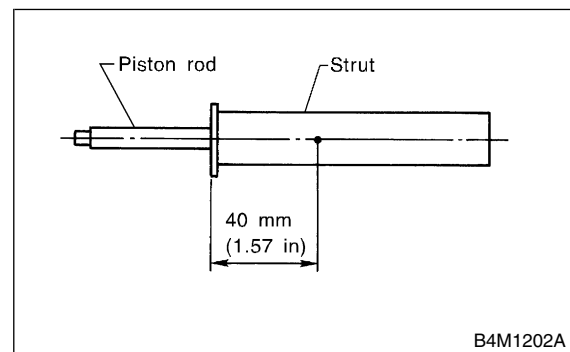

6. Front Stabilizer S202119

A: REMOVAL S202119A18

- 1) Jack-up the front part of the vehicle and support it with safety stand (rigid racks).
- 2) Remove jack-up plate from lower part of cross-member.
- 3) Remove bolts which secure stabilizer to cross-member.

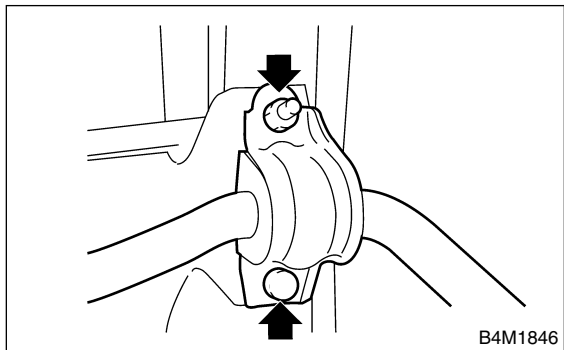

- 4) Remove bolts which secure stabilizer link to front transverse link.

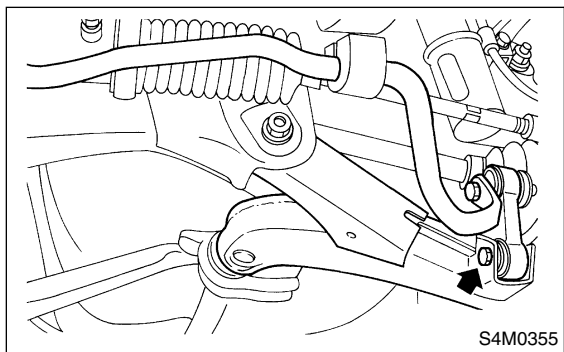

B: INSTALLATION S202119A11

- 1) Install in the reverse order of removal.

NOTE:

- Install bushing (on front crossmember side) while aligning it with paint mark on stabilizer.
- Ensure that bushing and stabilizer have the same identification colors when installing.

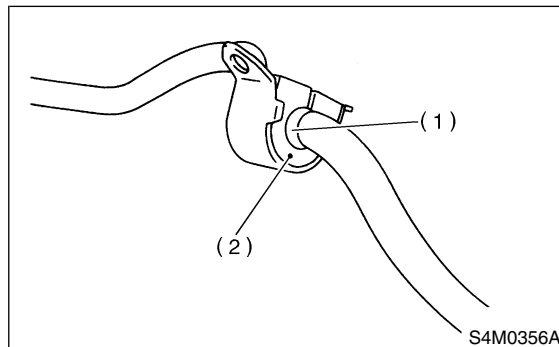

- (1) Mark stamped on stabilizer
- (2) Bushing identification color

- 2) Always tighten rubber bushing location when wheels are in full contact with the ground and vehicle is curb weight.

Tightening torque:

Jack-up plate to crossmember:

20 N·m (2.0 kgf·m, 14 ft·lb)

Stabilizer link to front transverse link:

30 N·m (3.1 kgf·m, 22 ft·lb)

Stabilizer to crossmember:

25 N·m (2.5 kgf·m, 18.1 ft·lb)

C: INSPECTION S202119A10

- 1) Check bushing for cracks, fatigue or damage.
- 2) Check stabilizer link for deformities, cracks, or damage, and bushing for protrusions from the hole of stabilizer link.

FRONT CROSSMEMBER

Front Suspension

7. Front Crossmember S202108

A: REMOVAL S202108A18

- 1) Set vehicle on a lift.
- 2) Disconnect ground cable from battery.
- 3) Lift-up vehicle and remove front tires and wheels.
- 4) Remove both stabilizer and jack-up plate.

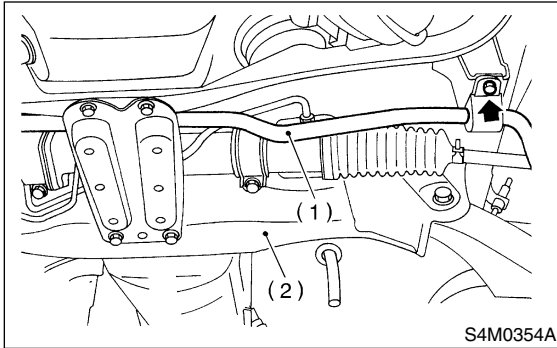

- (1) Front stabilizer
(2) Front crossmember

- 5) Disconnect tie-rod end from housing.
- 6) Remove front exhaust pipe.
- 7) Remove front transverse link from front crossmember and body.

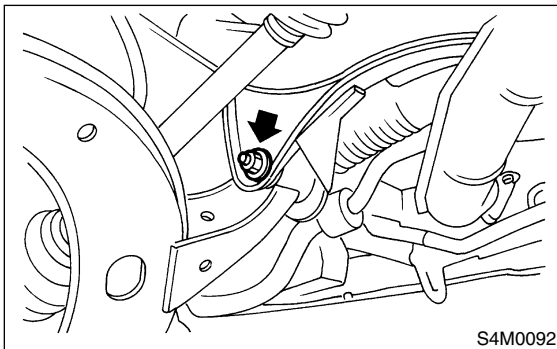

- 8) Remove nuts attaching engine mount cushion rubber to crossmember.

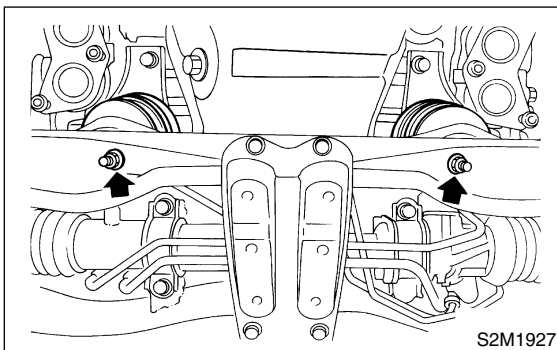

- 9) Remove steering universal joint. <Ref. to PS-18, REMOVAL, Universal Joint.>
- 10) Disconnect power steering pipe from steering gear box.

- 11) Lift engine by approx. 10 mm (0.39 in) by using chain block.
- 12) Support crossmember with a jack, remove nuts securing crossmember to body and lower crossmember gradually along with steering gear box.

CAUTION:
When removing crossmember downward, be careful that tie-rod end does not interfere with SFJ boot.

B: INSTALLATION S202108A11

- 1) Install in the reverse order of removal.

CAUTION:
Always tighten rubber bushing when wheels are in full contact with the ground and vehicle is curb weight.

Tightening torque:

Transverse link bushing to crossmember:

100 N·m (10.2 kgf-m, 74 ft-lb)

Stabilizer to bushing:

25 N·m (2.5 kgf-m, 18.1 ft-lb)

Tie-rod end to housing:

27.0 N·m (2.75 kgf-m, 19.9 ft-lb)

Front cushion rubber to crossmember:

75 N·m (7.6 kgf-m, 55.0 ft-lb)

Universal joint to pinion shaft:

24 N·m (2.4 kgf-m, 17.4 ft-lb)

Crossmember to body:

100 N·m (10.2 kgf-m, 74 ft-lb)

- 2) Purge air from power steering system.

NOTE:

Check wheel alignment and adjust if necessary.

C: INSPECTION S202108A10

Check crossmember for wear, damage and cracks, and correct or replace if defective.

8. General Diagnostic Table S202121

A: INSPECTION S202121A10

1. IMPROPER VEHICLE POSTURE OR IMPROPER WHEEL ARCH HEIGHT S202121A1001

Possible causes	Countermeasures
(1) Permanent distortion or breakage of coil spring	Replace.
(2) Unsmooth operation of damper strut and/or shock absorber	Replace.
(3) Installation of wrong strut and/or shock absorber	Replace with proper parts.
(4) Installation of wrong coil spring	Replace with proper parts.

2. POOR RIDE COMFORT S202121A1002

- 1) Large rebound shock
- 2) Rocking of vehicle continues too long after running over bump and/or hump.
- 3) Large shock in bumping

Possible causes	Countermeasures
(1) Breakage of coil spring	Replace.
(2) Overinflation pressure of tire	Adjust.
(3) Improper wheel arch height	Adjust or replace coil springs with new ones.
(4) Fault in operation of damper strut and/or shock absorber	Replace.
(5) Damage or deformation of strut mount and/or shock absorber mount	Replace.
(6) Unsuitability of maximum and/or minimum length of damper strut and/or shock absorber	Replace with proper parts.
(7) Deformation or loss of bushing	Replace.
(8) Deformation or damage of helper in strut assembly and/or shock absorber	Replace.
(9) Oil leakage of damper strut and/or shock absorber	Replace.

3. NOISE S202121A1003

Possible causes	Countermeasures
(1) Wear or damage of damper strut and/or shock absorber component parts	Replace.
(2) Loosening of suspension link installing bolt	Retighten to the specified torque.
(3) Deformation or loss of bushing	Replace.
(4) Unsuitability of maximum and/or minimum length of damper strut and/or shock absorber	Replace with proper parts.
(5) Breakage of coil spring	Replace.
(6) Wear or damage of ball joint	Replace.
(7) Deformation of stabilizer clamp	Replace.

GENERAL DIAGNOSTIC TABLE

Front Suspension

MEMO:

GENERAL DESCRIPTION

Rear Suspension

1. General Description S201001

A: SPECIFICATIONS S201001E49

Item	Sedan	Wagon	OUTBACK
Camber (tolerance: $\pm 0^\circ 45'$)	$-0^\circ 30'$	$-0^\circ 20'$	$-0^\circ 10'$
Toe-in	0 ± 3 mm (0 ± 0.12 in) Each toe-in angle: $\pm 0^\circ 15'$		
Wheel arch height [tolerance: $+^{12}/_{-24}$ mm ($+^{0.47}/_{-0.94}$ in)]	371 mm (14.61 in)	381 mm (15.00 in)	421 mm (16.57 in)
Thrust angle	$0^\circ \pm 30'$		
Diameter of stabilizer	14 mm (0.55 in)		

NOTE:

- Front and rear toe-ins and front camber can be adjusted. If toe-in or camber tolerance exceeds specifications, adjust toe-in and camber to the middle value of specification.
- The other items indicated in the specification table cannot be adjusted. If the other items exceeds specifications, check suspension parts and connections for deformities; replace with new ones as required.

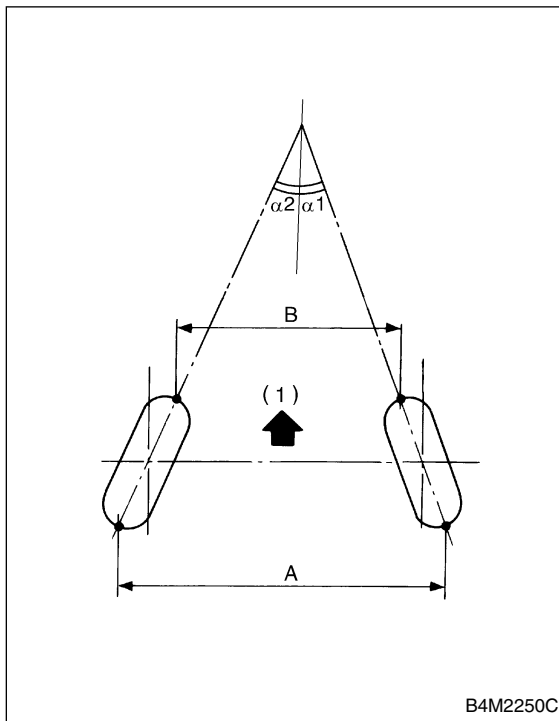

(1) Front

A - B = Positive: Toe-in, Negative: Toe-out

$\alpha 1, \alpha 2$: Each toe-in angle

B: COMPONENT

S201001A05

1. REAR SUSPENSION

S201001A0501

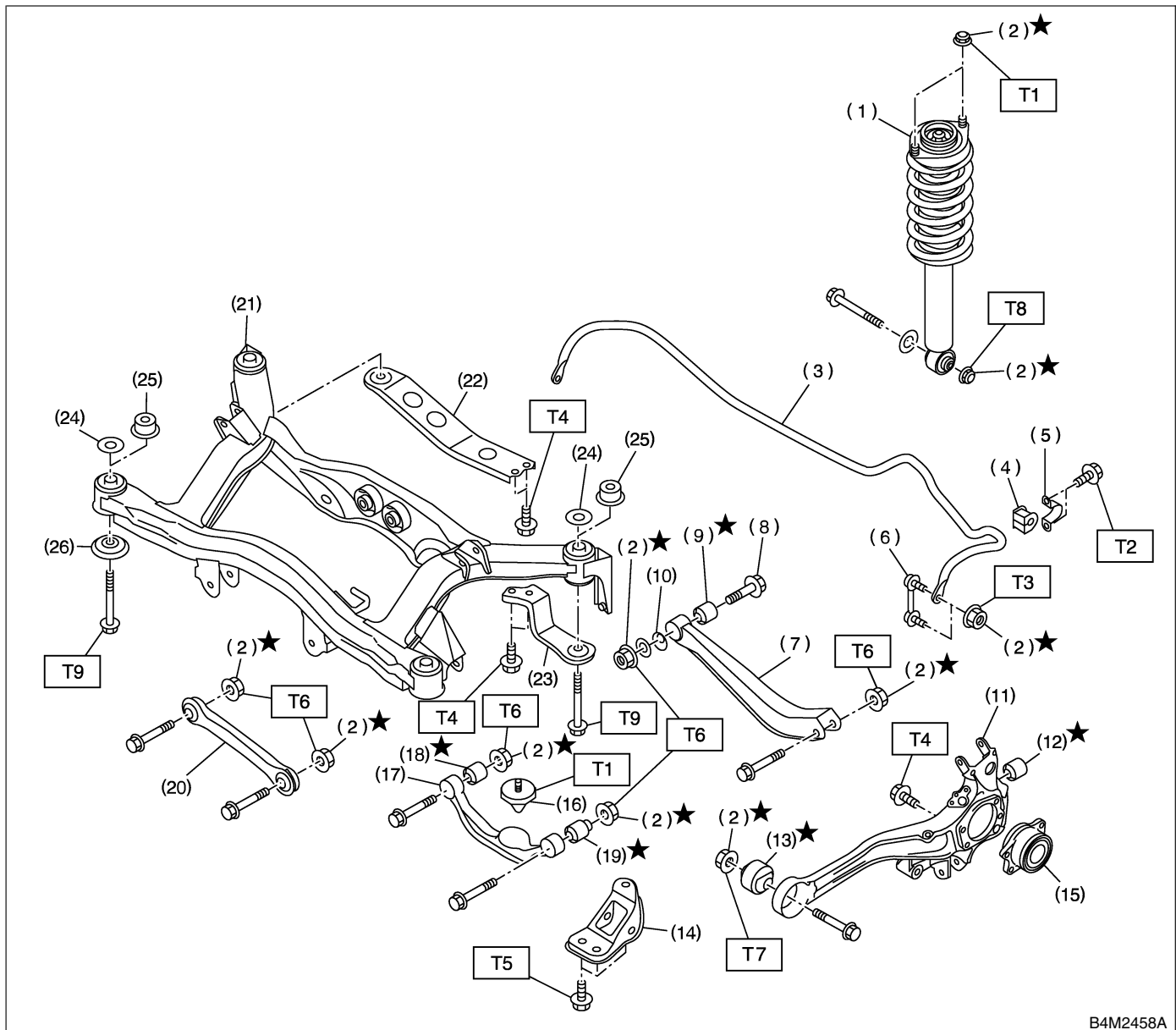

B4M2458A

- | | |
|-----------------------------|--|
| (1) Shock absorber | (15) Hub bearing unit |
| (2) Self-locking nut | (16) Helper |
| (3) Stabilizer | (17) Link upper |
| (4) Stabilizer bushing | (18) Link upper bushing (Inside) |
| (5) Clamp | (19) Link upper bushing (Outside) |
| (6) Stabilizer link | (20) Link front |
| (7) Link rear | (21) Rear sub frame |
| (8) Adjusting bolt | (22) Support sub frame (RH) |
| (9) Link rear bushing | (23) Support sub frame (LH) |
| (10) Adjusting washer | (24) Stopper upper (Except OUT-
BACK model) |
| (11) Rear arm | (25) Stopper upper (OUTBACK
MODEL) |
| (12) Rear arm rear bushing | (26) Stopper lower |
| (13) Rear arm front bushing | |
| (14) Rear arm bracket | |

Tightening torque: N·m (kgf·m, ft·lb)

T1: 30 (3.1, 22.4)

T2: 40 (4.1, 30)

T3: 44 (4.5, 32.5)

T4: 65 (6.6, 48)

T5: 110 (11.2, 81)

T6: 120 (12.2, 88)

T7: 150 (15.3, 111)

T8: 160 (16.3, 118)

T9: 176 (17.9, 129)

GENERAL DESCRIPTION

Rear Suspension

2. SHOCK ABSORBER S201001A0502

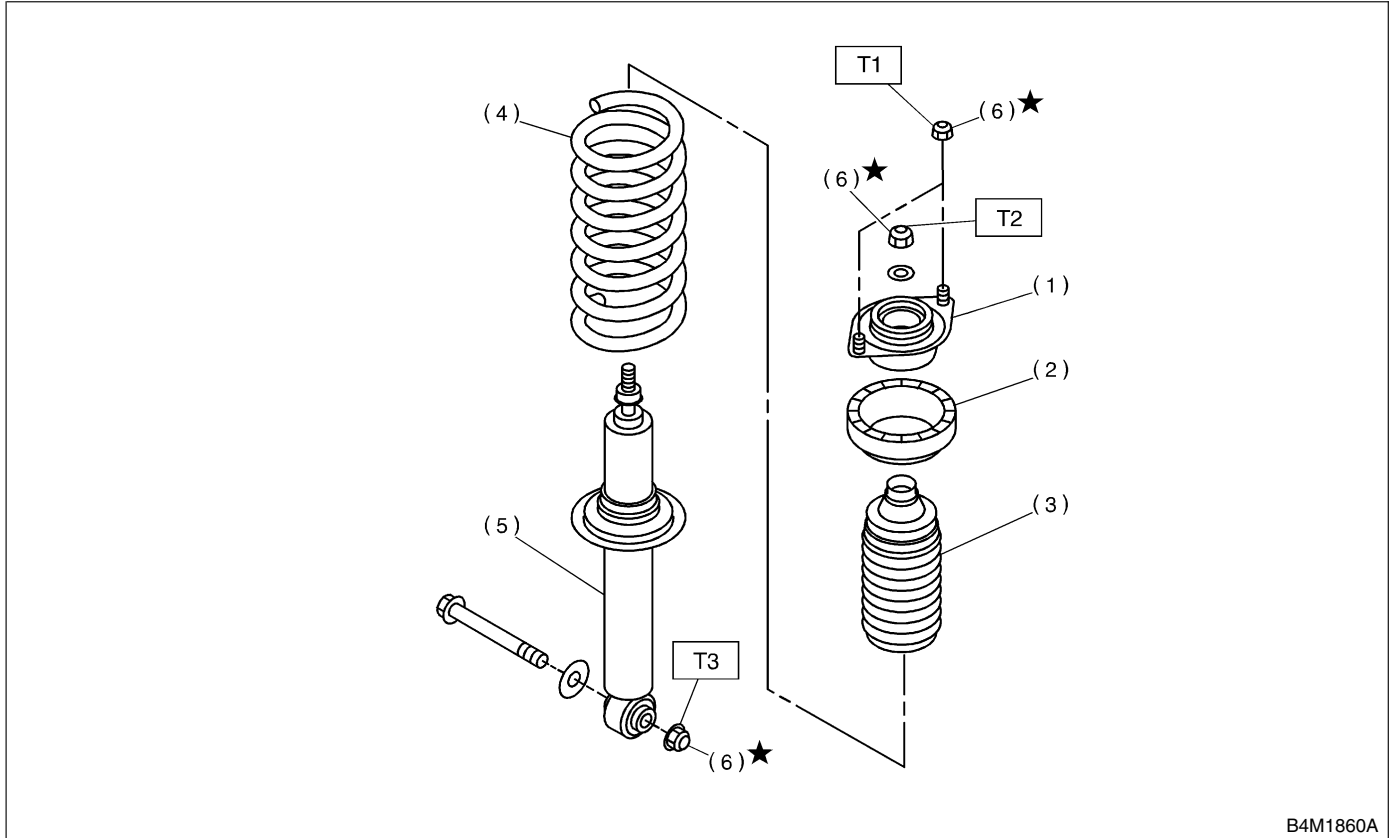

- (1) Mount
- (2) Rubber seat upper
- (3) Dust cover
- (4) Coil spring
- (5) Shock absorber
- (6) Self-locking nut

Tightening torque: N·m (kgf·m, ft·lb)

T1: 30 (3.1, 22.4)

T2: 35 (3.6, 26)

T3: 160 (16.3, 118)

C: CAUTION S201001A03

- Wear working clothing, including a cap, protective goggles, and protective shoes during operation.
- Remove contamination including dirt and corrosion before removal, installation or disassembly.
- Keep the disassembled parts in order and protect them from dust or dirt.
- Before removal, installation or disassembly, be sure to clarify the failure. Avoid unnecessary removal, installation, disassembly, and replacement.
- Use SUBARU genuine grease etc. or the equivalent. Do not mix grease etc. with that of another grade or from other manufacturers.
- Be sure to tighten fasteners including bolts and nuts to the specified torque.
- Place shop jacks or safety stands at the specified points.
- Apply grease onto sliding or revolution surfaces before installation.
- Before installing O-rings or snap rings, apply sufficient amount of grease to avoid damage and deformation.
- Before securing a part on a vise, place cushioning material such as wood blocks, aluminum plate, or shop cloth between the part and the vise.
- Before disposing shock absorbers, be sure to bleed gas completely. Also, do not throw away in fire.

GENERAL DESCRIPTION

Rear Suspension

D: PREPARATION TOOL S201001A17

1. SPECIAL TOOLS S201001A1701

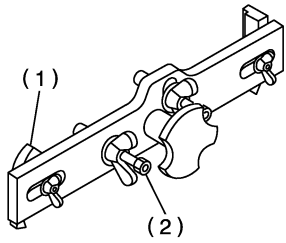
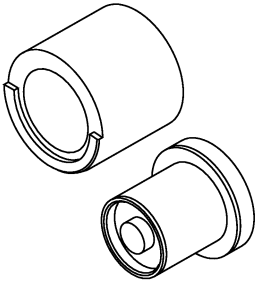
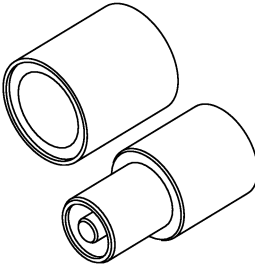
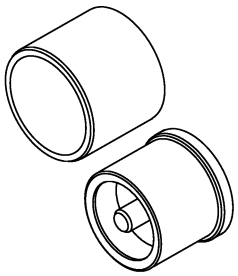
ILLUSTRATION	TOOL NUMBER	DESCRIPTION	REMARKS
 <p>B4M2378A</p>	927380002	ADAPTER	Used as an adapter for camber & caster gauge when measuring camber and caster. (1) 28199AC000 PLATE (2) 28199AC010 BOLT
 <p>B4M2379</p>	20099AE000	INSTALLER & REMOVER	Used for replacing link rear bushing.
 <p>B4M2380</p>	20099AE010	INSTALLER & REMOVER	Used for replacing link upper bushing.
 <p>B4M2381</p>	20099AE020	INSTALLER & REMOVER SET	Used for replacing rear arm front bushing.

GENERAL DESCRIPTION

Rear Suspension

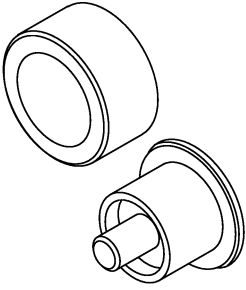
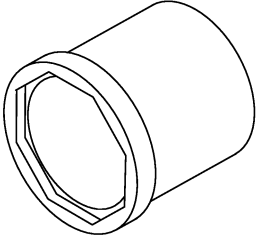
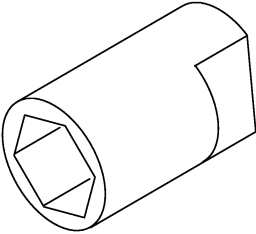
ILLUSTRATION	TOOL NUMBER	DESCRIPTION	REMARKS
 <p style="text-align: center;">B4M2382</p>	20099AE040	INSTALLER & REMOVER SET	Used for replacing rear arm rear bushing.
 <p style="text-align: center;">B4M2383</p>	20099AE030	HELPER SOCKET WRENCH	Used for replacing helper.
 <p style="text-align: center;">B4M2384</p>	927760000	STRUT MOUNT SOCKET	Used for disassembling and assembling strut and shock mount.

2. GENERAL PURPOSE TOOLS S201001A1702

TOOL NAME	REMARKS
Alignment gauge	Used for wheel alignment measurement.
Turning radius gauge	Used for wheel alignment measurement.
Toe-in gauge	Used for toe-in measurement.
Transmission jack	Used for suspension assembly/disassembly.
Bearing puller	Used for removing bushings.

WHEEL ALIGNMENT

Rear Suspension

2. Wheel Alignment S201116

A: INSPECTION S201116A10

NOTE:

The front and rear wheel alignment must be measured and/or adjusted at once to obtain accuracy. Measure and/or adjust the rear wheel alignment together with the front.

Follow the procedure in “FS” section “Wheel Alignment” for measurement and/or adjustment of wheel alignment. <Ref. to FS-6, Wheel Alignment.>

3. Rear Stabilizer S201118

A: REMOVAL S201118A18

- 1) Jack-up the rear part of the vehicle, support it with safety stands (rigid racks).
- 2) Remove bolts which secure stabilizer link to rear arm.

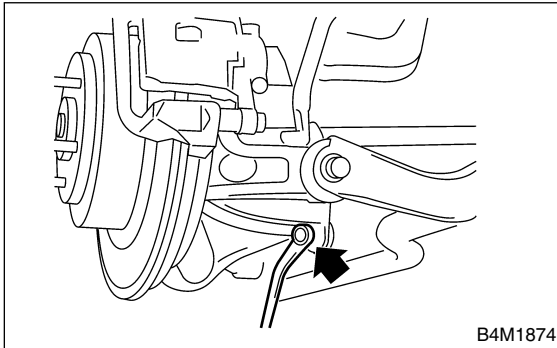

- 3) Remove bolts which secure stabilizer to sub frame.

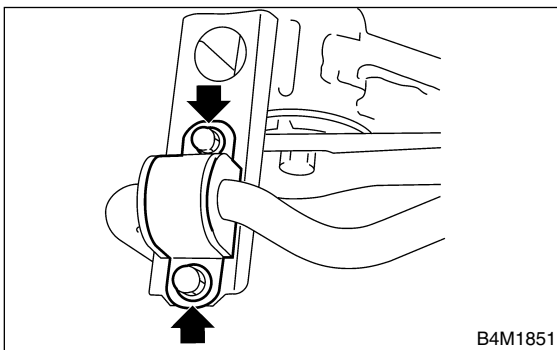

B: INSTALLATION S201118A11

Install in the reverse order of removal.

Tightening torque:

Stabilizer link to rear arm

44 N·m (4.5 kgf-m, 32.5 ft-lb)

Clamp to sub frame

40 N·m (4.1 kgf-m, 30 ft-lb)

C: INSPECTION S201118A10

- 1) Check bushing for cracks, fatigue or damage.
- 2) Check stabilizer links for deformities, cracks, or damage, and bushing for protrusions from the hole of stabilizer link.

REAR ARM

Rear Suspension

4. Rear Arm S201105

A: REMOVAL S201105A18

- 1) Lift-up the vehicle and remove rear wheel.
- 2) Remove bearing unit.
<Ref. to DS-22, REMOVAL, Hub Unit Bearing.>
- 3) Remove bolt securing parking brake cable clamp to rear arm.

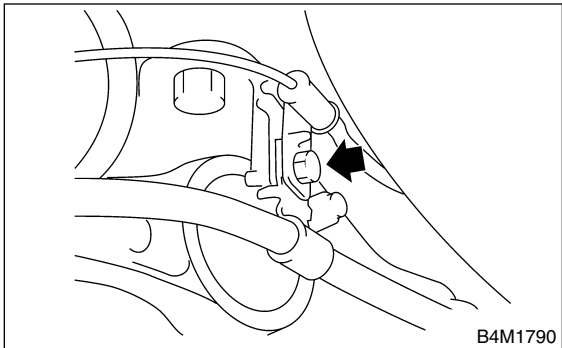

- 4) Remove bolt securing brake hose to rear arm.

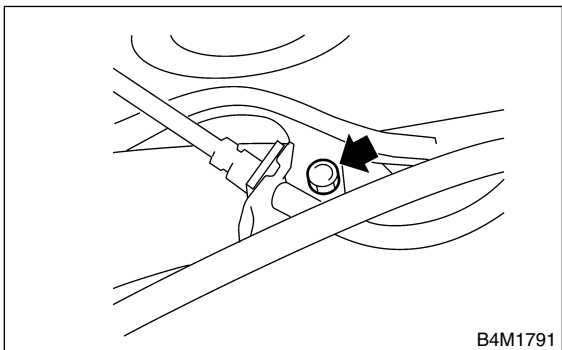

- 5) Remove bolt securing ABS sensor to rear arm.

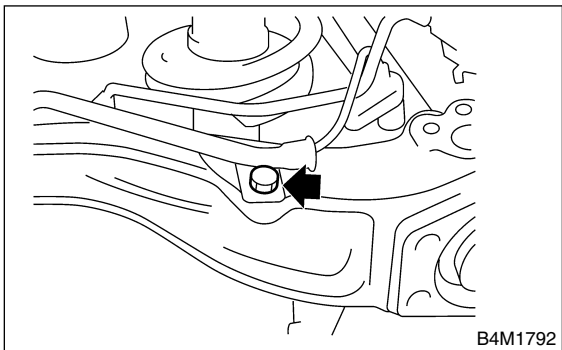

- 6) Suspend the back plate from sub frame.

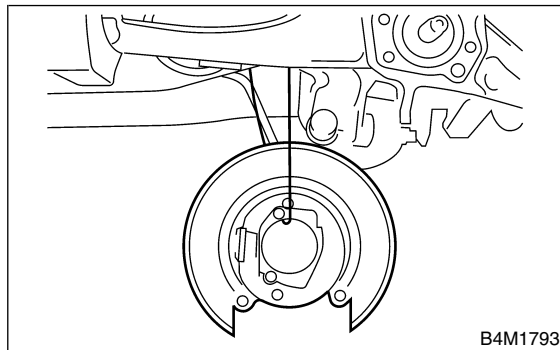

- 7) Remove nut securing stabilizer link to rear arm.

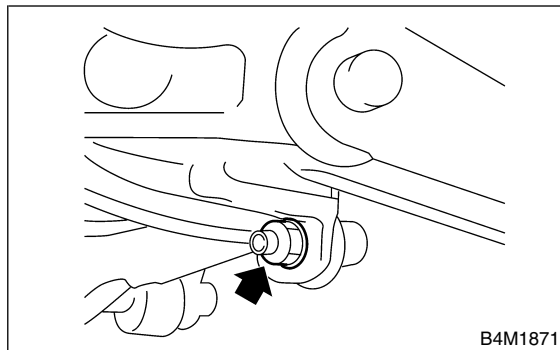

- 8) Remove bolt securing shock absorber to rear arm.

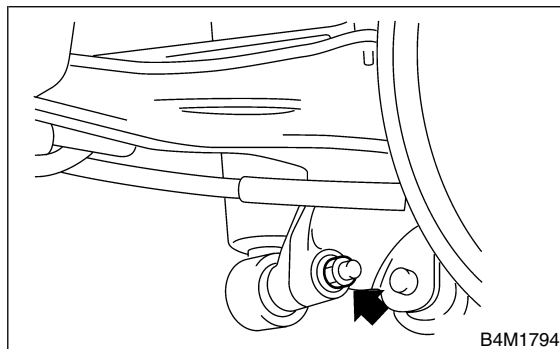

- 9) Use transmission jack to support rear arm horizontally.

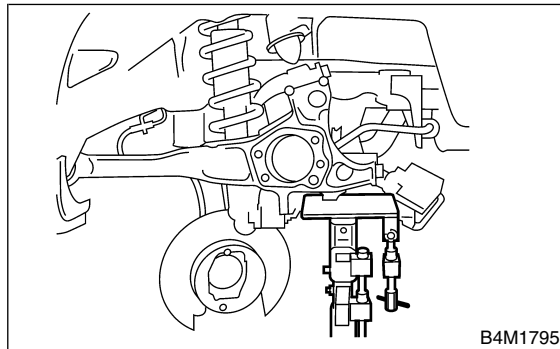

10) Remove bolt securing rear arm to body.

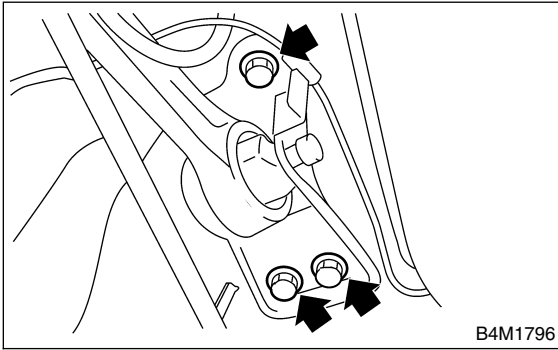

11) Loosen nut securing link front to rear arm.

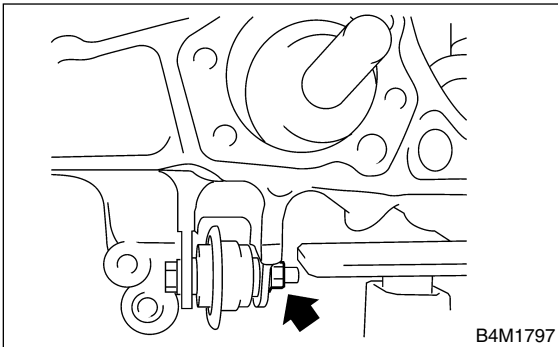

12) Loosen nut securing link rear to rear arm.

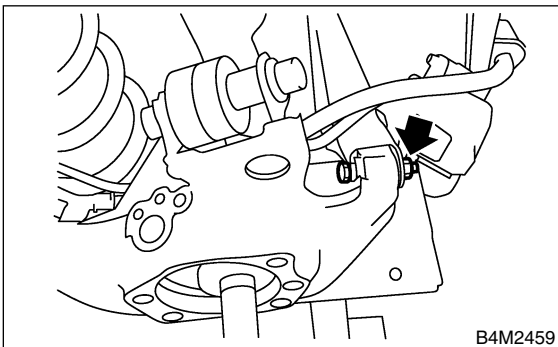

13) Loosen nut securing link upper to rear arm.

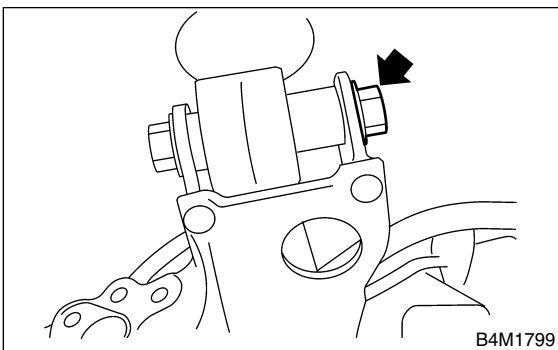

14) Remove bolts securing rear arm to links and remove rear arm.

B: INSTALLATION S201105A11

- 1) Use a transmission jack to support the rear arm.
- 2) Install rear arm and temporarily tighten bolts securing rear arm to links.
- 3) Install bearing unit.
<Ref. to DS-23, INSTALLATION, Hub Unit Bearing.>
- 4) Install bolt securing ABS sensor to rear arm.
- 5) Install bolt securing brake hose to rear arm.
- 6) Install bolt securing parking brake cable clamp to rear arm.
- 7) Place jack (furnished with vehicle) upside down and position it between link rear and sub frame. Adjust jack position so rear shock absorber is aligned with rear arm at their corresponding holes. Install lower shock absorber bolts.

CAUTION:
Put a cloth between jack and its mating area to protect link rear and sub frame from scratches.

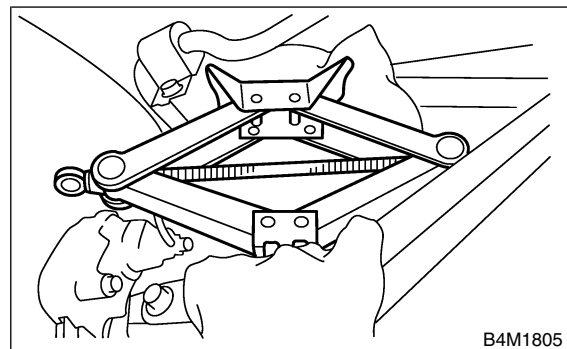

8) Using transmission jack, support rear arm horizontally and tighten nuts and bolts securing rear arm, link front, link rear, link upper and shock absorber.

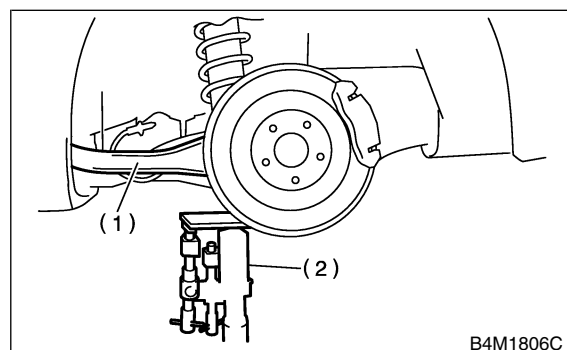

- (1) Rear arm
- (2) Transmission jack

REAR ARM

Rear Suspension

NOTE:

Check wheel alignment and adjust if necessary.

Tightening torque:

Refer to COMPONENT of General Description for tightening torque. <Ref. to RS-3, REAR SUSPENSION, COMPONENT, General Description.>

C: DISASSEMBLY S201105A06

1. FRONT BUSHING S201105A0601

1) Using ST-A, B, press front bushing out of place.
ST-A, B 20099AE020 INSTALLER & REMOVER SET

- (1) Set ST-A in position with larger inside diameter side facing up.
- (2) Set rear arm with protruded bushing side facing down.
- (3) Place ST-B on upper side of bushing, then press bushing out of position.

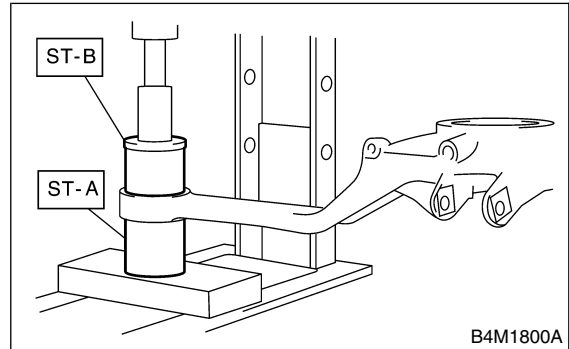

2. REAR BUSHING S201105A0602

Using ST-C and bearing puller, press rear bushing out of place.

ST-C 20099AE040 INSTALLER & REMOVER SET

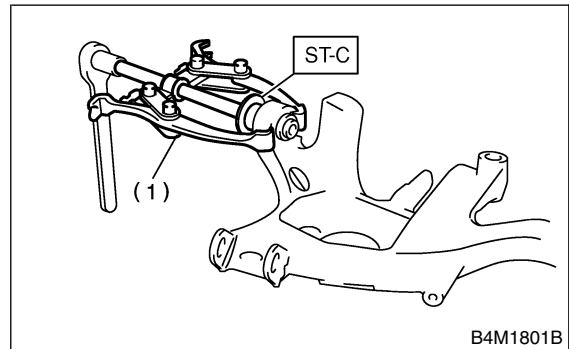

- (1) Bearing puller

D: ASSEMBLY S201105A02

1. FRONT BUSHING S201105A0201

1) Using ST-A, B, press bushing into trailing link.
 ST-A, B 20099AE020 INSTALLER &
 REMOVER SET

- (1) Set ST-A in position with smaller inside diameter side facing up.
- (2) Set rear arm in position with outer side of vehicle body facing down.
- (3) Place bushing on upper side of rear arm.
- (4) Place ST-B on upper side of bushing, then press bushing into position.

CAUTION:

- Install bushing with painted side facing up.
- Install front bushing in the proper direction, as shown in figure.

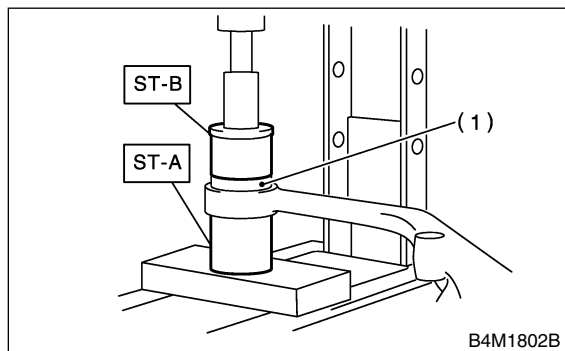
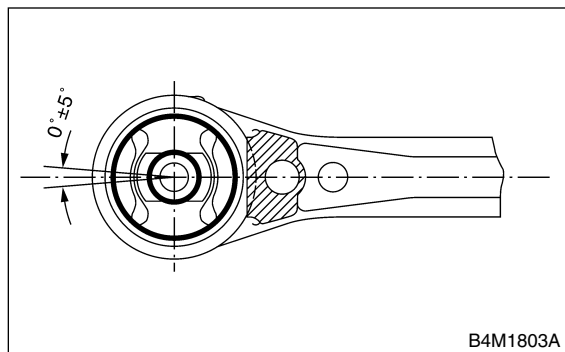

(1) Bushing

2. REAR BUSHING S201105A0202

1) Using ST-C, D and bearing puller, press bushing into trailing link.

ST-C, D 20099AE040 INSTALLER &
 REMOVER SET

- (1) Insert bushing into bore in ST-D.
- (2) Set ST-C, ST-D and bearing puller in position, as shown in the figure, and press bushing into position.

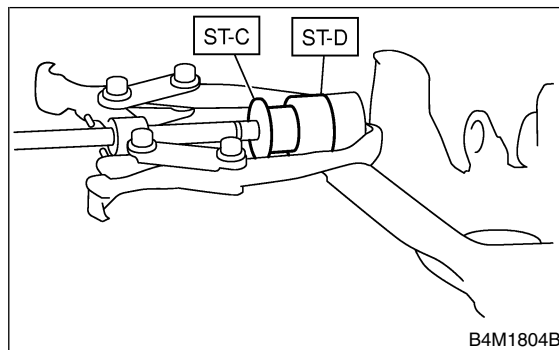

E: INSPECTION S201105A10

Check trailing links for bends, corrosion or damage.

LINK UPPER

Rear Suspension

5. Link Upper S201103

A: REMOVAL S201103A18

- 1) Loosen wheel nuts. Lift-up vehicle and remove wheel.
- 2) Use transmission jack to support rear arm horizontally.

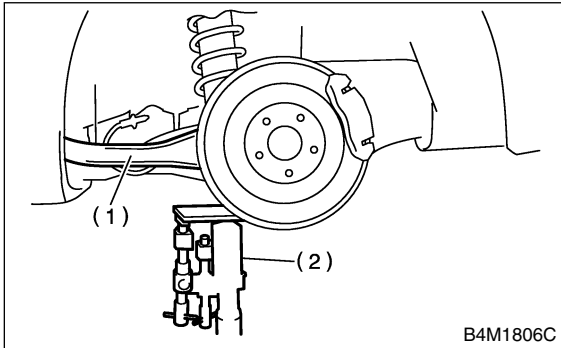

- (1) Rear arm
- (2) Transmission jack

- 3) Remove bolt securing link upper to sub frame.

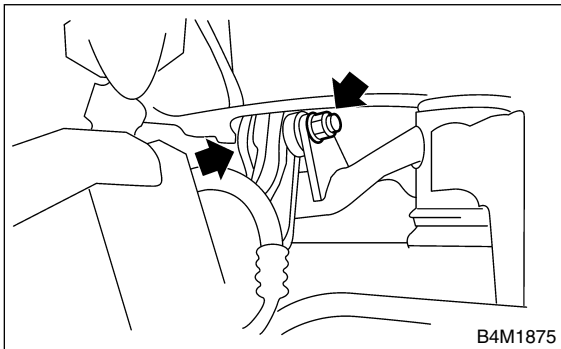

- 4) Remove bolts which secure link upper to rear arm and detach link upper.

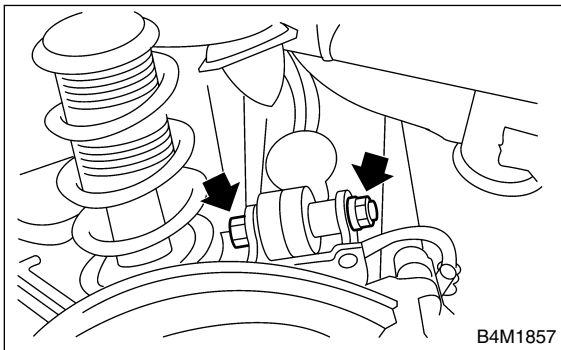

B: INSTALLATION S201103A11

Install in the reverse order of removal, observing the following instructions.

CAUTION:

- Using transmission jack, support rear arm horizontally, install link upper and tighten nuts to specified torque.

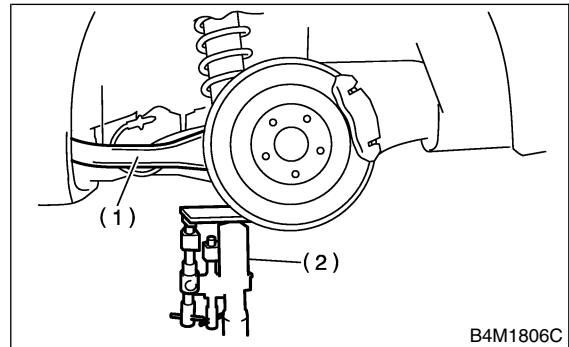

- (1) Rear arm
- (2) Transmission jack

- Tighten nut when installing adjusting bolt.
- Replace self-locking nut.

NOTE:

Check wheel alignment and adjust if necessary.

Tightening torque:

120 N·m (12.2 kgf·m, 88 ft·lb)

C: DISASSEMBLY S201103A06

Using ST, press bushing out of place.

ST 20099AE010 INSTALLER & REMOVER

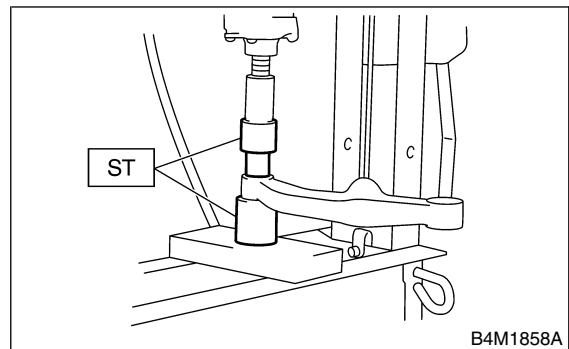

D: ASSEMBLY S201103A02

1) Using ST, press bushing into place.
ST 20099AE010 INSTALLER & REMOVER

CAUTION:
Outer bushing has a “directional” design. Be sure to install bushing with longer inner housing side facing vehicle rear.

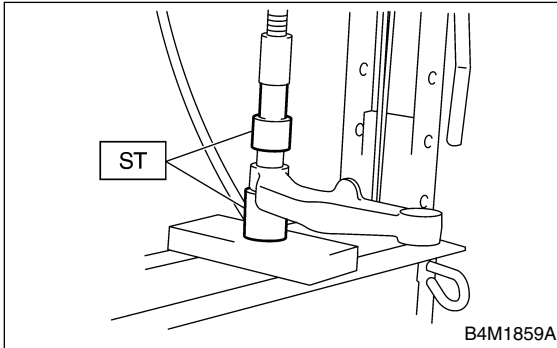

E: INSPECTION S201103A10

Visually check link upper for damage or bends.

REAR SHOCK ABSORBER

Rear Suspension

6. Rear Shock Absorber S201104

A: REMOVAL S201104A18

- 1) Lift-up vehicle and remove rear wheels.
- 2) Remove clip and detach floor mat. (Wagon model)

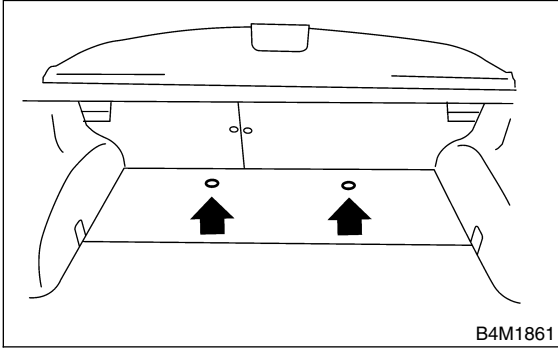

- 3) Detach trunk mat. (Sedan model)
- 4) Roll up the trunk side trim. (Sedan model)

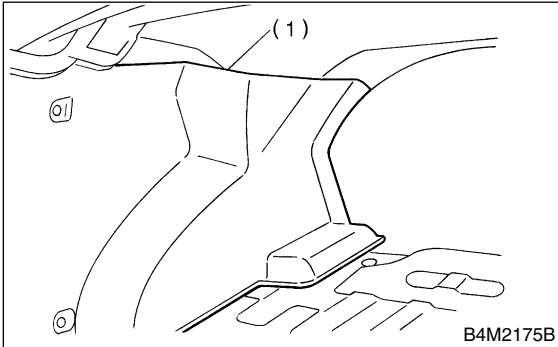

(1) Trunk side trim

- 5) Remove bolt securing shock absorber to rear arm.

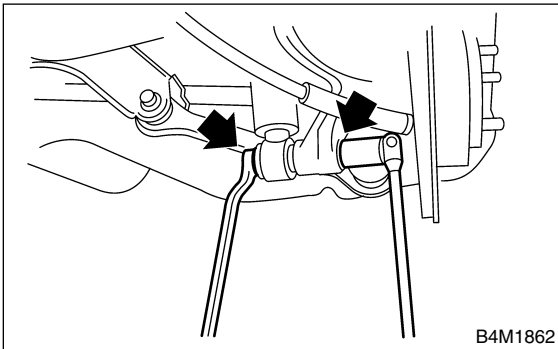

- 6) Use a jack to support the shock absorber.

- 7) Remove nuts securing shock absorber mount to body.

● Wagon

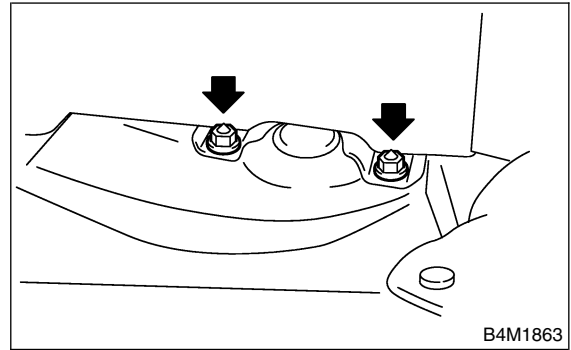

● Sedan

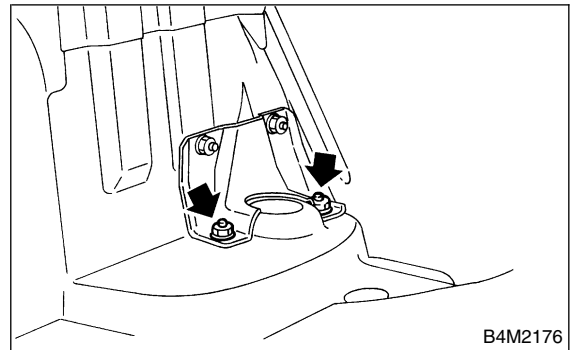

- 8) Remove shock absorber.

B: INSTALLATION S201104A11

- 1) Use a jack to support the shock absorber.
- 2) Tighten self-locking nut used to secure shock absorber to vehicle body.

CAUTION:

Use a new self-locking nut.

Tightening torque:

30 N·m (3.1 kgf·m, 22 ft-lb)

- 3) Place jack (furnished with vehicle) upside down and position it between link rear and sub frame. Adjust jack position so rear shock absorber is aligned with rear arm at their corresponding holes. Install lower shock absorber bolts.

CAUTION:

Put a cloth between jack and its mating area to protect link rear and sub frame from scratches.

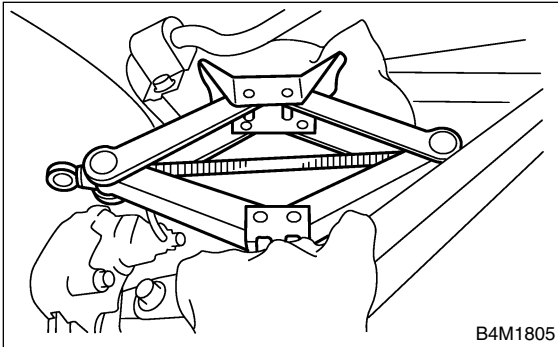

- 4) Using transmission jack, support rear arm horizontally and tighten shock absorber nuts and bolts to specified torque.

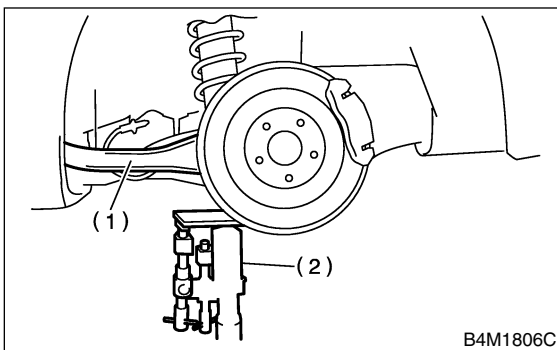

- (1) Rear arm
- (2) Transmission jack

Tightening torque:

160 N·m (16.3 kgf·m, 118 ft-lb)

CAUTION:

Use a new self-locking nut.

- 5) Install floor mat. (Wagon model)
- 6) Set trunk side trim. (Sedan model)
- 7) Install trunk mat. (Sedan model)

NOTE:

Check wheel alignment and adjust if necessary.

C: DISASSEMBLY S201104A06

For disassembly of shock absorber, refer to procedures outlined under front strut as a guide.
<Ref. to FS-18, DISASSEMBLY, Front Strut.>

D: ASSEMBLY S201104A02

Refer to Front Strut as a guide for assembly procedures.
<Ref. to FS-19, ASSEMBLY, Front Strut.>

E: INSPECTION S201104A10

Refer to Front Strut as a guide for inspection procedures.
<Ref. to FS-20, INSPECTION, Front Strut.>

F: DISPOSAL S201104A07

CAUTION:

- Before handling shock absorber, be sure to wear goggles to protect eyes from gas, oil and/or filings.
- Completely discharge the gas from the shock absorber before disposal. Follow the disposal procedure outlined below.
- Do not disassemble shock absorber or place into a fire.
- Drill holes before disposing of shock absorber.

- 1) Place shock absorber on a flat and level surface with piston rod fully extended.
- 2) Using a 2 to 3 mm (0.08 to 0.12 in) dia. drill, drill 30 mm (1.18 in) deep holes in areas shown in the figure.

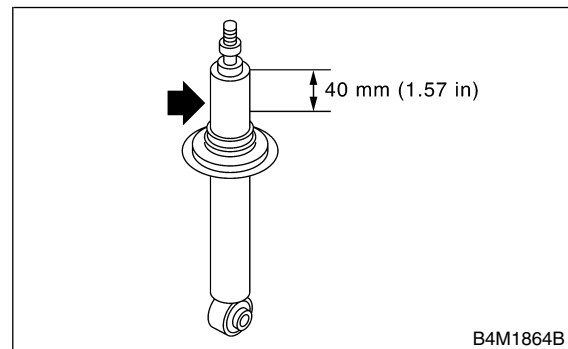

LINK FRONT

Rear Suspension

7. Link Front S201106

A: REMOVAL S201106A18

- 1) Loosen wheel nuts. Lift-up vehicle and remove wheel.
- 2) Use transmission jack to support rear arm horizontally.

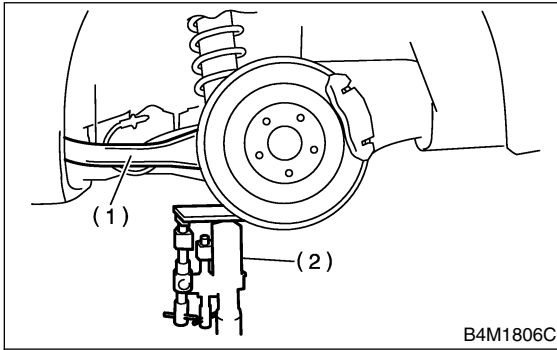

- (1) Rear arm
- (2) Transmission jack

- 3) Remove bolt securing link front to sub frame.

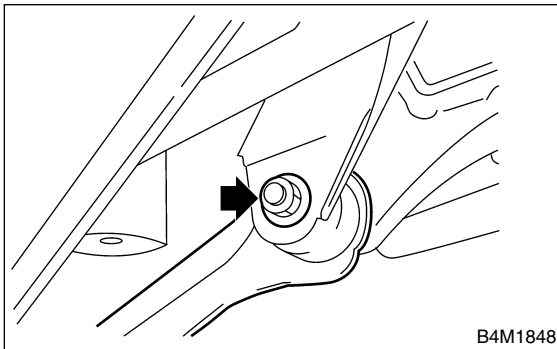

- 4) Remove bolts which secure link front to rear arm and detach link front.

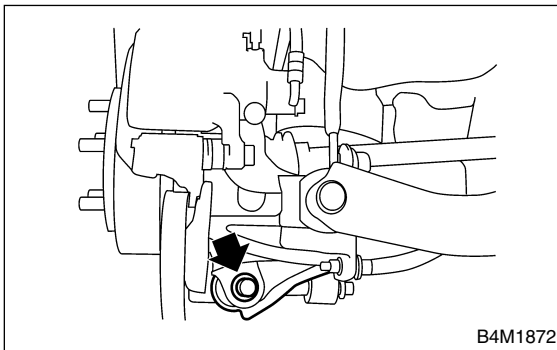

NOTE:
Link front bushing cannot be replaced alone.
Always replace link front and bushing as a single unit.

B: INSTALLATION S201106A11

Install in the reverse order of removal, observing the following instructions.

CAUTION:

- Using transmission jack, support rear arm horizontally, install link front and tighten nuts to specified torque.

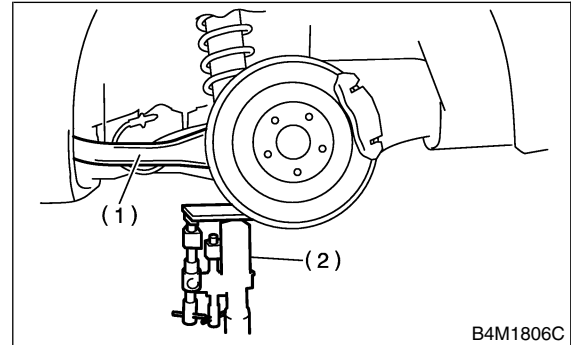

- (1) Rear arm
- (2) Transmission jack

- Install link front with protruded side facing front.

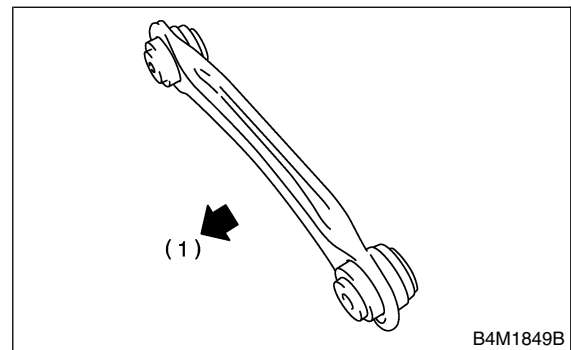

- (1) Front

- Replace self-locking nut.

NOTE:
Check wheel alignment and adjust if necessary.

C: INSPECTION S201106A10

Visually check link front for damage or bends.

8. Link Rear S201102

A: REMOVAL S201102A18

- 1) Loosen wheel nuts. Lift-up vehicle and remove wheel.
- 2) Remove bolt securing stabilizer clamps to sub frame.

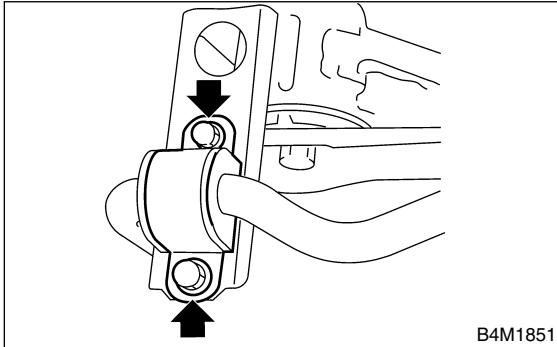

- 3) Remove support sub frame RH. (When removing RH side link rear.)

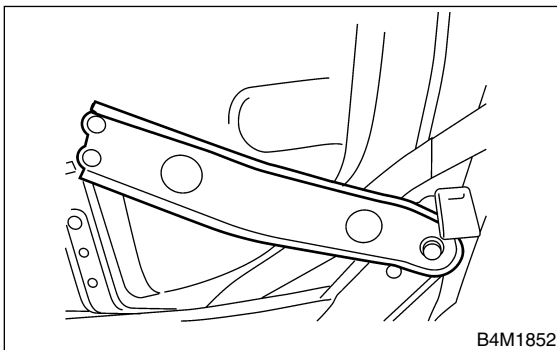

- 4) Remove stabilizer link.

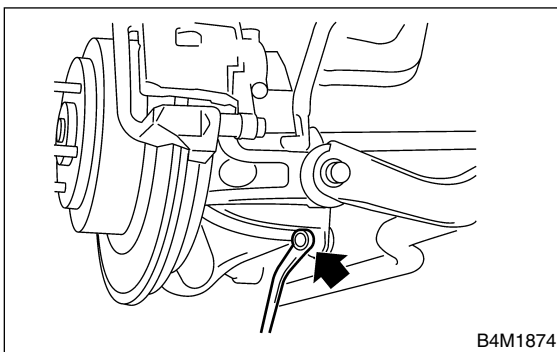

- 5) Use transmission jack to support rear arm horizontally.

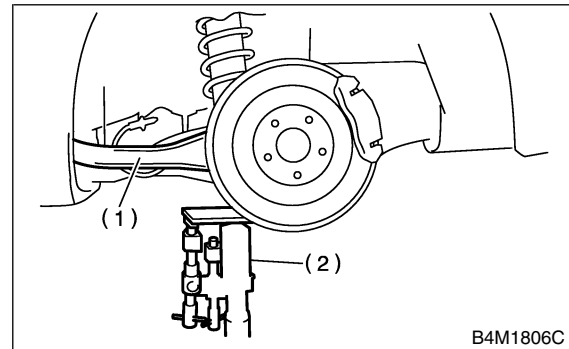

- (1) Rear arm
- (2) Transmission jack

- 6) Remove bolt securing link rear to rear arm.

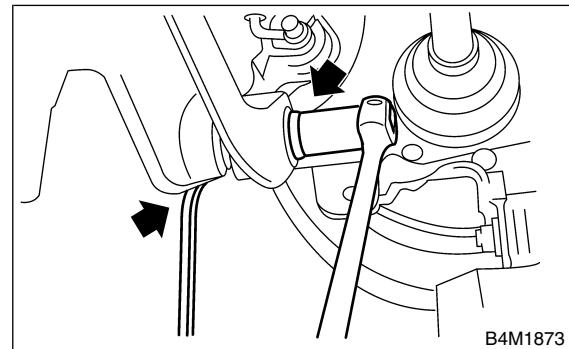

- 7) Scribe an alignment mark on link rear adjusting bolt and sub frame.
- 8) Remove bolts securing link rear to sub frame, detach link rear.

CAUTION:

To loosen adjusting bolt, always loosen nut while holding the head of adjusting bolt.

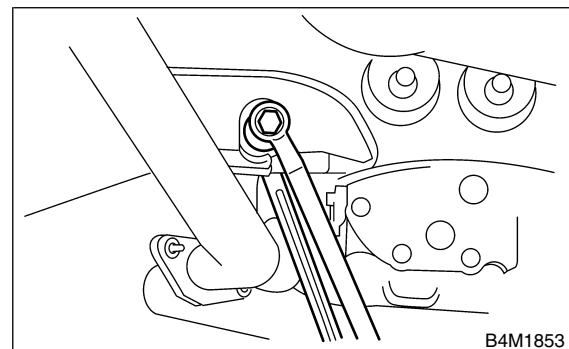

LINK REAR

Rear Suspension

B: INSTALLATION S201102A11

Install in the reverse order of removal, observing the following instructions.

CAUTION:

- Using transmission jack, support rear arm horizontally, install link rear and tighten nuts to specified torque.

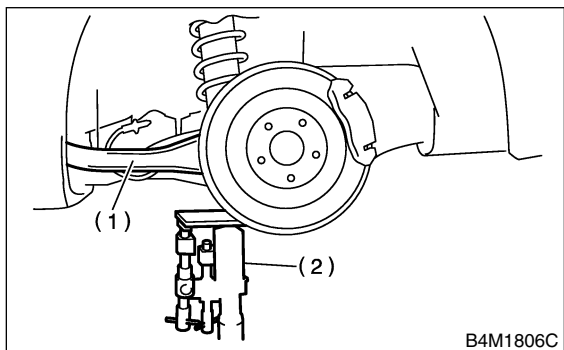

- (1) Rear arm
- (2) Transmission jack

- Tighten nut when installing adjusting bolt.
- Replace self-locking nut.

NOTE:

Check wheel alignment and adjust if necessary.

C: DISASSEMBLY S201102A06

Using ST-A, B, press bushing out of place.
ST-A, B 20099AE000 INSTALLER & REMOVER

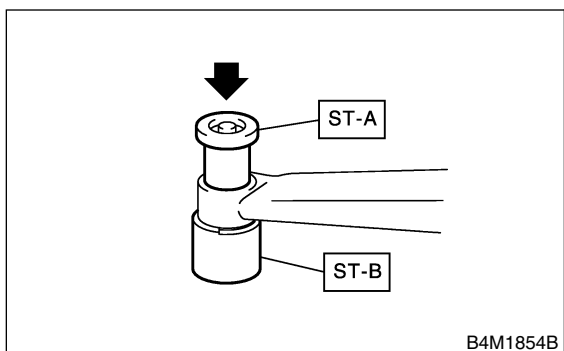

D: ASSEMBLY S201102A02

Using ST, press bushing into place.
ST-A, B 20099AE000 INSTALLER & REMOVER

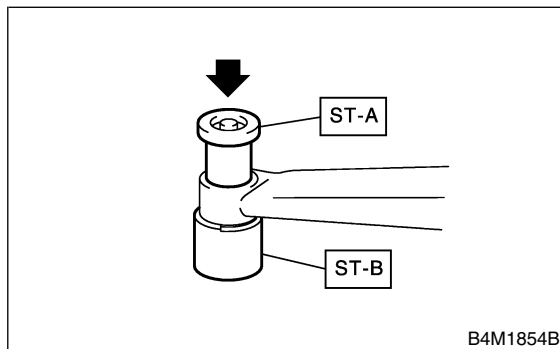

E: INSPECTION S201102A10

Visually check link rear for damage or bends.

9. Rear Sub Frame S201111

A: REMOVAL S201111A18

1) Separate front exhaust pipe and rear exhaust pipe.

2) Remove rear exhaust pipe and muffler.

3) Remove rear differential.

With T-type

<Ref. to DI-25, REMOVAL, Rear Differential for T-type.>

With VA-type

<Ref. to DI-43, REMOVAL, Rear Differential for VA-type.>

4) Disconnect link front from sub frame.

<Ref. to RS-18, REMOVAL, Link Front.>

5) Disconnect link rear from sub frame.

<Ref. to RS-19, REMOVAL, Link Rear.>

6) Disconnect link upper from sub frame.

<Ref. to RS-14, REMOVAL, Link Upper.>

7) Place transmission jack under sub frame.

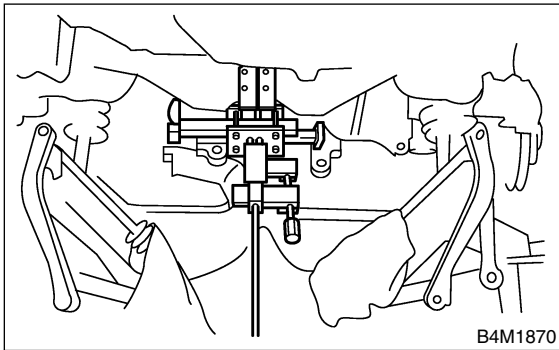

8) After removing bolts, remove sub frame and support sub frame from vehicle body.

B: INSTALLATION S201111A11

1) Install in reverse order of removal.

2) For installation and tightening torque of rear differential.

With T-type

<Ref. to DI-26, INSTALLATION, Rear Differential for T-type.>

With VA-type

<Ref. to DI-44, INSTALLATION, Rear Differential for VA-type.>

3) Using transmission jack, support rear arm horizontally and tighten nuts and bolts securing rear arm, link front, link rear, link upper and shock absorber.

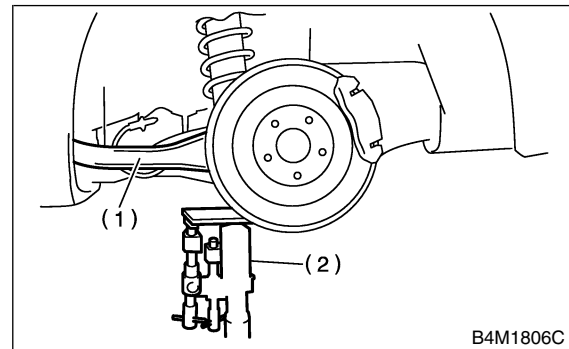

(1) Rear arm

(2) Transmission jack

NOTE:

Check wheel alignment and adjust if necessary.

C: INSPECTION S201111A10

Check removed parts for wear, damage and cracks, and correct or replace if defective.

10. Helper S201539

A: REMOVAL S201539A18

- 1) Jack-up the rear part of the vehicle, support it with safety stands (rigid racks).
 - 2) Using ST, remove helper.
- ST 20099AE030 HELPER SOCKET WRENCH

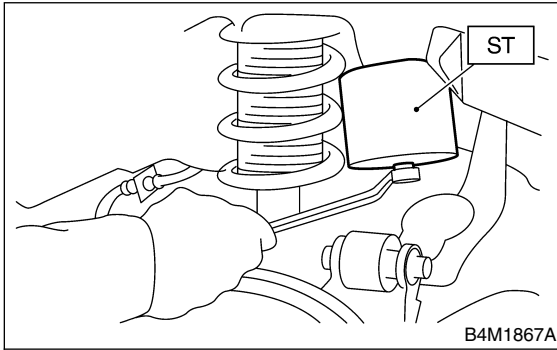

B: INSTALLATION S201539A11

Install in the reverse order of removal.

Tightening torque:

30 N·m (3.1 kgf·m, 22 ft·lb)

C: INSPECTION S201539A10

Check helper for cracks, fatigue or damage.

11. General Diagnostic Table S201257

A: INSPECTION S201257A10

1. IMPROPER VEHICLE POSTURE OR IMPROPER WHEEL ARCH HEIGHT S201257A1001

Possible causes	Countermeasures
(1) Permanent distortion or breakage of coil spring	Replace.
(2) Unsmooth operation of damper strut and/or shock absorber	Replace.
(3) Installation of wrong strut and/or shock absorber	Replace with proper parts.
(4) Installation of wrong coil spring	Replace with proper parts.

2. POOR RIDE COMFORT S201257A1002

- 1) Large rebound shock
- 2) Rocking of vehicle continues too long after running over bump and/or hump.
- 3) Large shock in bumping

Possible causes	Countermeasures
(1) Breakage of coil spring	Replace.
(2) Overinflation pressure of tire	Adjust.
(3) Improper wheel arch height	Adjust or replace coil springs with new ones.
(4) Fault in operation of damper strut and/or shock absorber	Replace.
(5) Damage or deformation of strut mount and/or shock absorber mount	Replace.
(6) Unsuitability of maximum and/or minimum length of damper strut and/or shock absorber	Replace with proper parts.
(7) Deformation or loss of bushing	Replace.
(8) Deformation or damage of helper in strut assembly and/or shock absorber	Replace.
(9) Oil leakage of damper strut and/or shock absorber	Replace.

3. NOISE S201257A1003

Possible causes	Countermeasures
(1) Wear or damage of damper strut and/or shock absorber component parts	Replace.
(2) Loosening of suspension link installing bolt	Retighten to the specified torque.
(3) Deformation or loss of bushing	Replace.
(4) Unsuitability of maximum and/or minimum length of damper strut and/or shock absorber	Replace with proper parts.
(5) Breakage of coil spring	Replace.
(6) Wear or damage of ball joint	Replace.
(7) Deformation of stabilizer clamp	Replace.

GENERAL DIAGNOSTIC TABLE

Rear Suspension

MEMO:

GENERAL DESCRIPTION

Wheel and Tire System

1. General Description S204001

A: SPECIFICATIONS S204001E49

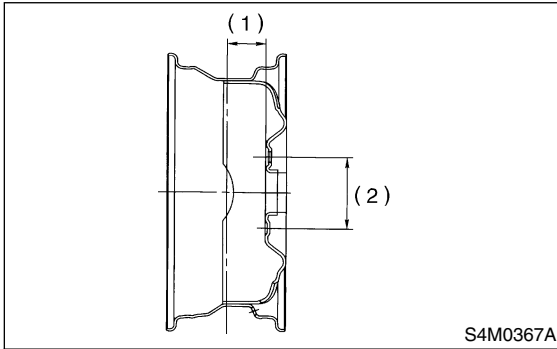

- (1) Offset
- (2) P.C.D.

		Tire size	Rim size	Rim offset mm (in)	P.C.D. mm (in)
Except OUTBACK	Front and Rear	P195/60R15 87H	15 × 6JJ	55 (2.17)	100 (3.94) dia.
		P205/60R15 90H	15 × 6JJ	55 (2.17)	
		P205/55R16 89H	16 × 6 1/2JJ	55 (2.17)	
T-type tire	T135/70D16	16 × 4T	50 (1.97)		
OUTBACK	Front and Rear	P225/60R16 97H	16 × 6 1/2JJ	48 (1.89)	
	T-type tire	T145/80R16	16 × 4T	50 (1.97)	

		Tire size	Tire inflation pressure kPa (kg/cm ² , psi)	
			Light load	Trailer towing
Except OUTBACK	Front and Rear	P195/60R15 87H	Ft: 230 (2.3, 33)	—
		P205/60R15 90H	Rr: 220 (2.2, 32)	
		P205/55R16 89H	Ft: 220 (2.2, 32) Rr: 210 (2.1, 30)	
	T-type tire	T135/70D16	420 (4.2, 60)	—
OUTBACK model	Front and Rear	225/60R16 97H	Ft: 210 (2.1, 30) Rr: 200 (2.0, 29)	Ft: 210 (2.1, 30) Rr: 220 (2.2, 32)
	T-type tire	T145/80R16	420 (4.2, 60)	—

NOTE: "T-type" tire for temporary use is supplied as a spare tire.

GENERAL DESCRIPTION

Wheel and Tire System

1. SERVICE DATA S204001E4901

Item	Axial runout	Radial runout
Steel wheel	1.5 mm (0.059 in)	
Aluminum wheel	1.0 mm (0.039 in)	

2. ADJUSTING PARTS S204001E4902

Wheel balancing	Standard	Service limit
Dynamic unbalance	Less than 5 g (0.18 oz)	

Balance weight part number (For steel wheel)	Weight
28101AA001	5 g (0.18 oz)
28101AA011	10 g (0.35 oz)
28101AA021	15 g (0.53 oz)
28101AA031	20 g (0.71 oz)
28101AA041	25 g (0.88 oz)
28101AA051	30 g (1.06 oz)
28101AA061	35 g (1.23 oz)
28101AA071	40 g (1.41 oz)
28101AA081	45 g (1.59 oz)
28101AA091	50 g (1.76 oz)
—	55 g (1.94 oz)
28101AA111	60 g (2.12 oz)

Balance weight part number (For aluminum wheel)	Weight
23141GA462	5 g (0.18 oz)
23141GA472	10 g (0.35 oz)
23141GA482	15 g (0.53 oz)
23141GA492	20 g (0.71 oz)
23141GA502	25 g (0.88 oz)
23141GA512	30 g (1.06 oz)
23141GA522	35 g (1.23 oz)
23141GA532	40 g (1.41 oz)
23141GA542	45 g (1.59 oz)
23141GA552	50 g (1.76 oz)
—	55 g (1.94 oz)
23141GA572	60 g (2.12 oz)

B: PREPARATION TOOL S204001A17

1. GENERAL PURPOSE TOOLS S204001A1701

TOOL NAME	REMARKS
Air pressure gauge	Used for measuring tire air pressure.
Dial gauge	Used for measuring wheel runout.

2. Tire S204125

A: INSPECTION S204125A10

- 1) Take stone, glass, nail etc. off the tread groove.
- 2) Replace tire:

CAUTION:

- When replacing a tire, make sure to use only the same size, construction and load range as originally installed.
- Avoid mixing radial, belted bias or bias tires on the vehicle.

- (1) When large crack on side wall, damage or crack on tread is found.
- (2) When the "tread wear indicator" appears as a solid band across the tread.

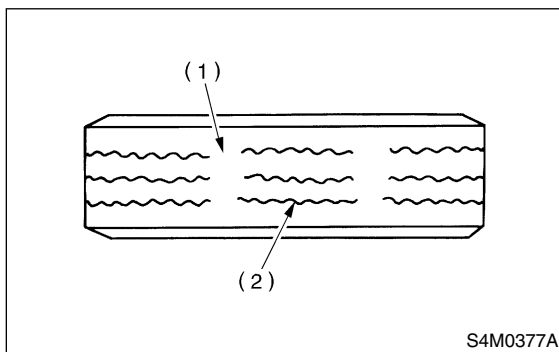

- (1) Tread wear indicator
- (2) Tire tread

- 3) When extremely biased wear on tire tread can be seen, after replacing tire, measure wheel alignment. <Ref. to FS-6, Wheel Alignment.>

1. TIRE ROTATION S204125A1001

If tires are maintained at the same positions for a long period of time, uneven wear results. Therefore, they should be periodically rotated. This lengthens service life of tires.

CAUTION:

When rotating tires, replace unevenly worn or damaged tires with new ones.

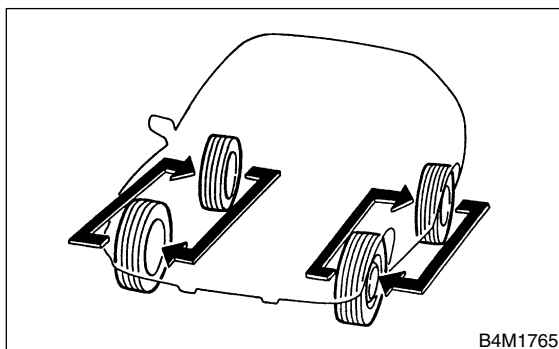

3. Steel Wheel S204131

A: REMOVAL S204131A18

- 1) Apply parking brake, and position select lever to "P" or "LOW".
- 2) Set shop jacks or a lift to the specified point, and support the vehicle with its wheels slightly contacting the floor.
- 3) Loosen wheel nuts.
- 4) Raise the vehicle until its wheels take off the ground using a jack or a lift.
- 5) Remove wheel nuts and wheels.

NOTE:

- While removing wheels, prevent hub bolts from damage.
- Place wheels with their outer sides facing upward to prevent wheels from damage.

B: INSTALLATION S204131A11

- 1) Attach the wheel to the hub by aligning the wheel bolt hole with the hub bolt.
- 2) Temporarily attach the wheel nuts to the hub bolts. (In the case of aluminum wheel, use SUBARU genuine wheel nut for aluminum wheel.)
- 3) Manually tighten the nuts making sure the wheel hub hole is aligned correctly to the guide portion of hub.
- 4) Tighten the wheel nuts in a diagonal selection to the specified torque. Use a wheel nut wrench.

Wheel nut tightening torque:
88 N·m (9 kgf-m, 65 ft-lb)

CAUTION:

- Tighten the wheel nuts in two or three steps by gradually increasing the torque and working diagonally, until the specified torque is reached. For drum brake models, excess tightening of wheel nuts may cause wheels to "judder".
- Do not depress the wrench with a foot; Always use both hands when tightening.
- Make sure the bolt, nut and the nut seating surface of the wheel are free from oils.

- 5) If a wheel is removed for replacement or for repair of a puncture, retighten the wheel nuts to the specified torque after running 1,000 km (600 miles).

C: INSPECTION S204131A10

- 1) Deformation or damage on the rim can cause air leakage. Check the rim flange for deformation, crack, or damage, and repair or replace as necessary.
- 2) Jack-up vehicle until wheels clear the floor.
- 3) Slowly rotate wheel to check rim "runout" using a dial gauge.

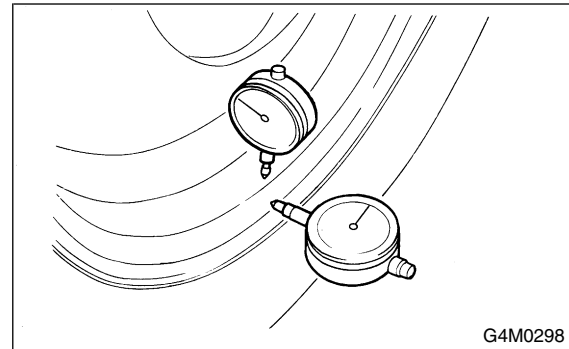

Axial runout limit	Radial runout limit
1.5 mm (0.059 in)	

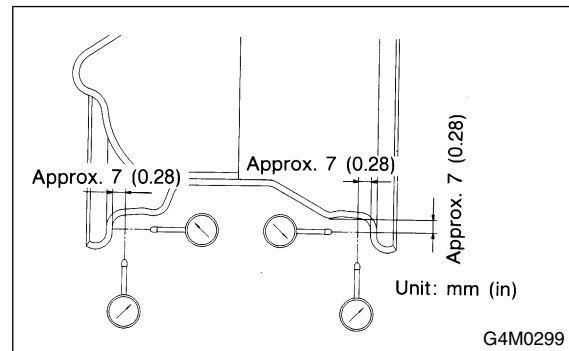

- 4) If rim runout exceeds specifications, remove tire from rim and check runout while attaching dial gauge to positions shown in figure.
- 5) If measured runout still exceeds specifications, replace the wheel.

4. Aluminum Wheel S204130

A: REMOVAL S204130A18

Refer to Steel Wheel for removal procedure of aluminum wheels. <Ref. to WT-5, REMOVAL Steel Wheel.>

B: INSTALLATION S204130A11

Refer to Steel Wheel for installation procedure of aluminum wheels. < Ref. to WT-5, INSTALLATION, Steel Wheel.>

C: INSPECTION S204130A10

Refer to Steel Wheel for inspection procedure of aluminum wheels. <Ref. to WT-5, INSPECTION, Steel Wheel.>

Rim runout:

Axial runout limit	Radial runout limit
1.0 mm (0.039 in)	

D: CAUTION S204130A03

Aluminum wheels are easily scratched. To maintain their appearance and safety, do the following:

- 1) Do not damage aluminum wheels during removal, disassembly, installation, wheel balancing, etc. After removing aluminum wheels, place them on a rubber mat, etc.

- 2) While vehicle is being driven, be careful not to ride over sharp obstacles or allow aluminum wheels to contact the shoulder of the road.

- 3) When installing tire chain, be sure to install it properly not to have a slack; otherwise it may hit wheel while driving.

- 4) When washing aluminum wheel, use neutral synthetic detergent and water. Avoid using the cleanser including abrasive, hard brushes or an automatic car washer.

5. Wheel Balancing S204127

A: REPLACEMENT S204127A20

- 1) Remove balance weights.
- 2) Using dynamic balancing, measure wheel balance.
- 3) Select a weight close to the value measured by dynamic balancing.

Balance weight part number (For steel wheel)	Weight
28101AA001	5 g (0.18 oz)
28101AA011	10 g (0.35 oz)
28101AA021	15 g (0.53 oz)
28101AA031	20 g (0.71 oz)
28101AA041	25 g (0.88 oz)
28101AA051	30 g (1.06 oz)
28101AA061	35 g (1.23 oz)
28101AA071	40 g (1.41 oz)
28101AA081	45 g (1.59 oz)
28101AA091	50 g (1.76 oz)
—	55 g (1.94 oz)
28101AA111	60 g (2.12 oz)

Balance weight part number (For aluminum wheel)	Weight
23141GA462	5 g (0.18 oz)
23141GA472	10 g (0.35 oz)
23141GA482	15 g (0.53 oz)
23141GA492	20 g (0.71 oz)
23141GA502	25 g (0.88 oz)
23141GA512	30 g (1.06 oz)
23141GA522	35 g (1.23 oz)
23141GA532	40 g (1.41 oz)
23141GA542	45 g (1.59 oz)
23141GA552	50 g (1.76 oz)
—	55 g (1.94 oz)
23141GA572	60 g (2.12 oz)

- 4) Install the selected weight to the point designated by dynamic balancing.
- 5) Using dynamic balancing, measure wheel balance again. Check that wheel balance is correctly adjusted.

B: INSPECTION S204127A10

- 1) Proper wheel balance may be lost if the tire is repaired or if it wears. Check the tire for dynamic balance, and repair as necessary.
- 2) To check for dynamic balance, use a dynamic balancer. Drive in the balance weight on both the top and rear sides of the rim.
- 3) Some types of balancer can cause damage to the wheel. Use an appropriate balancer when adjusting the wheel balance.
- 4) Use genuine balance weights.

CAUTION:

- **55 g (1.94 oz) weight used with aluminum wheel is not available.**
- **Balance weights are available for use with any of 14- to 16-inch wheels.**

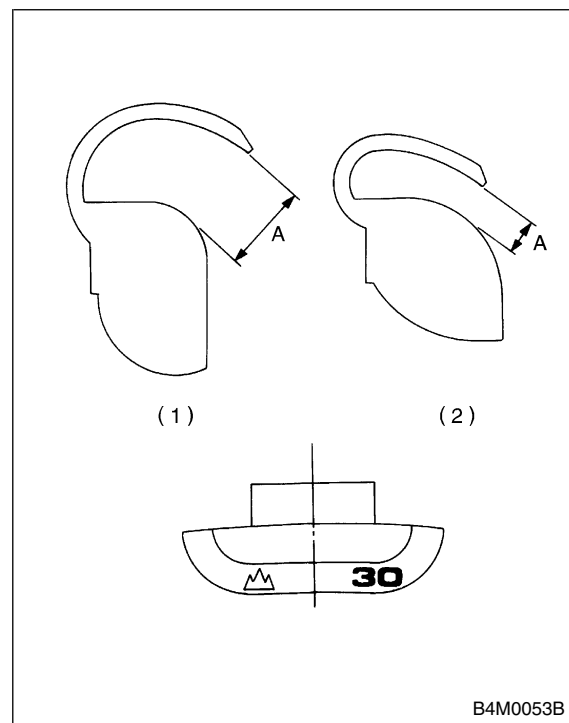

- (1) Weight for aluminum wheel
- (2) Weight for steel wheel

Service limit: A

**Weight for steel wheel;
2.16 mm (0.0850 in)**

**Weight for aluminum wheel;
4.5 mm (0.177 in)**

6. “T-type” Tire S204129

A: NOTE S204129A15

“T-type” tire for temporary use is prepared as a spare tire.

CAUTION:

- Do not use a tire chain with the “T-type” tire. Because of the smaller tire size, a tire chain will not fit properly and will result in damage to the vehicle and the tire.
- Do not drive at a speed greater than 80 km/h (50 MPH).
- Drive as slowly as possible and avoid passing over bumps.

B: REPLACEMENT S204129A20

Refer to Removal and Installation of Steel Wheel for removal/installation of “T-type” tires. <Ref. to WT-5, Steel Wheel.>

CAUTION:

Replace with a conventional tire as soon as possible since the “T-type” tire is only for temporary use.

C: INSPECTION S204129A10

- 1) Check tire inflation pressure.

Specification:

420 kPa (4.2 kg/cm², 60 psi)

- 2) Take stones, glass, nails, etc. out of the tread groove.
- 3) Check tires for deformation, cracks, partial wear, or wear.

CAUTION:

Replace the tire with a new one.

7. Full Wheel Cap S204128

A: REMOVAL S204128A18

Pry off the full wheel cap with a wheel cap remover inserted between openings in the cap.

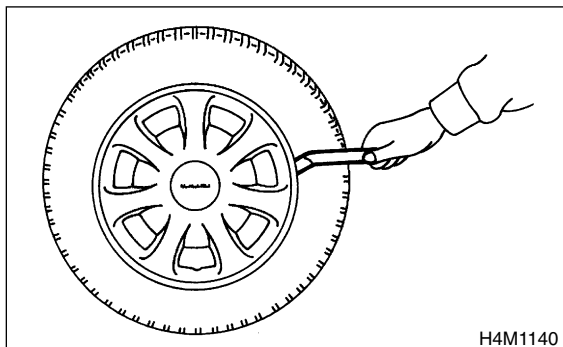

B: INSTALLATION S204128A11

Align the valve hole in the wheel cap with the valve on the wheel and secure the wheel cap by tapping four points by hand.

C: INSPECTION S204128A10

- 1) Check wheels for missing wheel caps.
- 2) Check pawls of wheel caps for damage or bend.
- 3) Check wheel caps for cracks.

GENERAL DIAGNOSTIC TABLE

Wheel and Tire System

8. General Diagnostic Table S204257

A: INSPECTION S204257A10

Symptom	Possible cause	Remedy
Front wheel shimmy	● Worn or improperly inflated of tire.	Replace
	● Wheel is out of balance.	Adjustment
Abnormal tire wear	● Improperly inflated of tire.	Replace
Sways/pitches	● Worn or improperly inflated of tire.	Replace
Wander/pulls	● Worn or improperly inflated of tire.	Replace