

REAR SHOCK ABSORBER

Rear Suspension

6. Rear Shock Absorber S201104

A: REMOVAL S201104A18

- 1) Lift-up vehicle and remove rear wheels.
- 2) Remove clip and detach floor mat. (Wagon model)

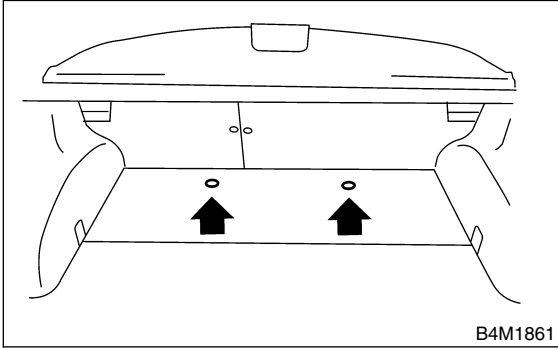

- 3) Detach trunk mat. (Sedan model)
- 4) Roll up the trunk side trim. (Sedan model)

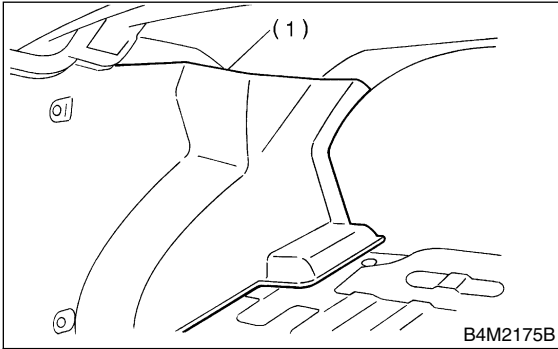

(1) Trunk side trim

- 5) Remove bolt securing shock absorber to rear arm.

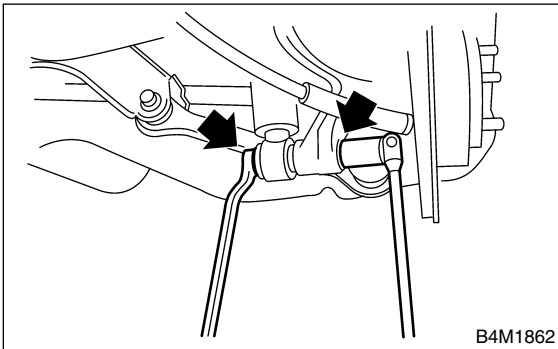

- 6) Use a jack to support the shock absorber.

- 7) Remove nuts securing shock absorber mount to body.

● Wagon

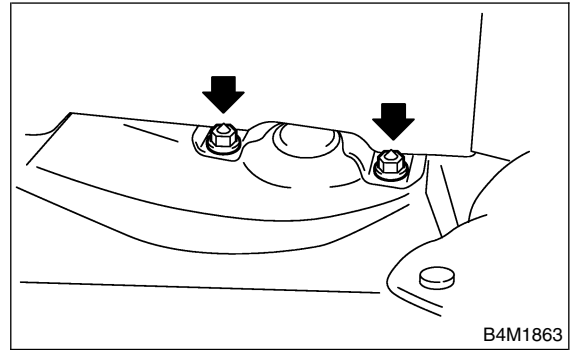

● Sedan

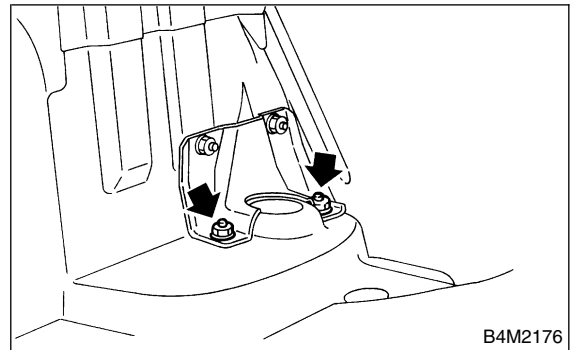

- 8) Remove shock absorber.

B: INSTALLATION S201104A11

- 1) Use a jack to support the shock absorber.
- 2) Tighten self-locking nut used to secure shock absorber to vehicle body.

CAUTION:

Use a new self-locking nut.

Tightening torque:

30 N·m (3.1 kgf·m, 22 ft·lb)

- 3) Place jack (furnished with vehicle) upside down and position it between link rear and sub frame. Adjust jack position so rear shock absorber is aligned with rear arm at their corresponding holes. Install lower shock absorber bolts.

CAUTION:

Put a cloth between jack and its mating area to protect link rear and sub frame from scratches.

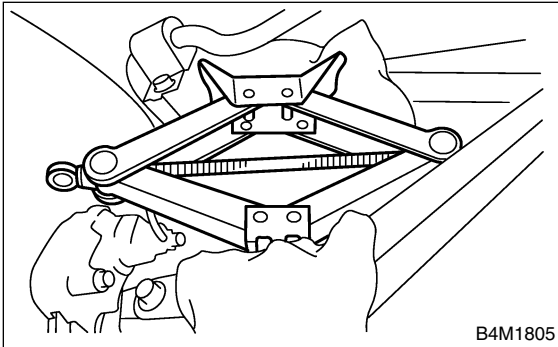

- 4) Using transmission jack, support rear arm horizontally and tighten shock absorber nuts and bolts to specified torque.

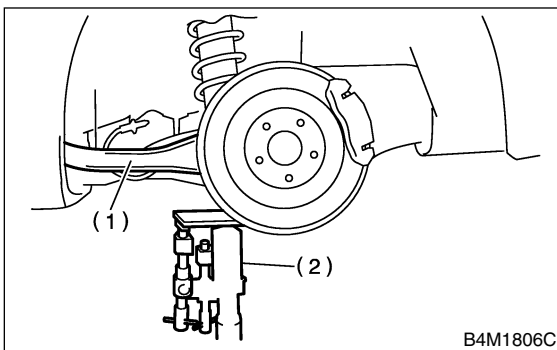

- (1) Rear arm
- (2) Transmission jack

Tightening torque:

160 N·m (16.3 kgf·m, 118 ft·lb)

CAUTION:

Use a new self-locking nut.

- 5) Install floor mat. (Wagon model)
- 6) Set trunk side trim. (Sedan model)
- 7) Install trunk mat. (Sedan model)

NOTE:

Check wheel alignment and adjust if necessary.

C: DISASSEMBLY S201104A06

For disassembly of shock absorber, refer to procedures outlined under front strut as a guide.
<Ref. to FS-18, DISASSEMBLY, Front Strut.>

D: ASSEMBLY S201104A02

Refer to Front Strut as a guide for assembly procedures.
<Ref. to FS-19, ASSEMBLY, Front Strut.>

E: INSPECTION S201104A10

Refer to Front Strut as a guide for inspection procedures.
<Ref. to FS-20, INSPECTION, Front Strut.>

F: DISPOSAL S201104A07

CAUTION:

- Before handling shock absorber, be sure to wear goggles to protect eyes from gas, oil and/or filings.
- Completely discharge the gas from the shock absorber before disposal. Follow the disposal procedure outlined below.
- Do not disassemble shock absorber or place into a fire.
- Drill holes before disposing of shock absorber.

- 1) Place shock absorber on a flat and level surface with piston rod fully extended.
- 2) Using a 2 to 3 mm (0.08 to 0.12 in) dia. drill, drill 30 mm (1.18 in) deep holes in areas shown in the figure.

