

9. Rear Sub Frame S201111

A: REMOVAL S201111A18

1) Separate front exhaust pipe and rear exhaust pipe.

2) Remove rear exhaust pipe and muffler.

3) Remove rear differential.

With T-type

<Ref. to DI-25, REMOVAL, Rear Differential for T-type.>

With VA-type

<Ref. to DI-43, REMOVAL, Rear Differential for VA-type.>

4) Disconnect link front from sub frame.

<Ref. to RS-18, REMOVAL, Link Front.>

5) Disconnect link rear from sub frame.

<Ref. to RS-19, REMOVAL, Link Rear.>

6) Disconnect link upper from sub frame.

<Ref. to RS-14, REMOVAL, Link Upper.>

7) Place transmission jack under sub frame.

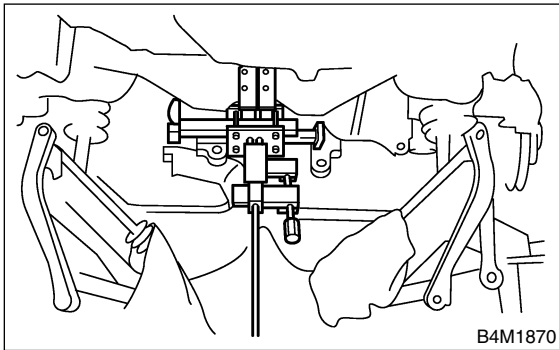

8) After removing bolts, remove sub frame and support sub frame from vehicle body.

B: INSTALLATION S201111A11

1) Install in reverse order of removal.

2) For installation and tightening torque of rear differential.

With T-type

<Ref. to DI-26, INSTALLATION, Rear Differential for T-type.>

With VA-type

<Ref. to DI-44, INSTALLATION, Rear Differential for VA-type.>

3) Using transmission jack, support rear arm horizontally and tighten nuts and bolts securing rear arm, link front, link rear, link upper and shock absorber.

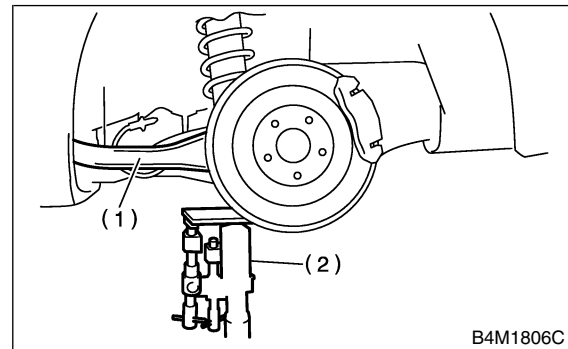

(1) Rear arm

(2) Transmission jack

NOTE:

Check wheel alignment and adjust if necessary.

C: INSPECTION S201111A10

Check removed parts for wear, damage and cracks, and correct or replace if defective.