

## 3. Steel Wheel S204131

### A: REMOVAL S204131A18

- 1) Apply parking brake, and position select lever to "P" or "LOW".
- 2) Set shop jacks or a lift to the specified point, and support the vehicle with its wheels slightly contacting the floor.
- 3) Loosen wheel nuts.
- 4) Raise the vehicle until its wheels take off the ground using a jack or a lift.
- 5) Remove wheel nuts and wheels.

**NOTE:**

- While removing wheels, prevent hub bolts from damage.
- Place wheels with their outer sides facing upward to prevent wheels from damage.

### B: INSTALLATION S204131A11

- 1) Attach the wheel to the hub by aligning the wheel bolt hole with the hub bolt.
- 2) Temporarily attach the wheel nuts to the hub bolts. (In the case of aluminum wheel, use SUBARU genuine wheel nut for aluminum wheel.)
- 3) Manually tighten the nuts making sure the wheel hub hole is aligned correctly to the guide portion of hub.
- 4) Tighten the wheel nuts in a diagonal selection to the specified torque. Use a wheel nut wrench.

**Wheel nut tightening torque:**  
**88 N·m (9 kgf-m, 65 ft-lb)**

**CAUTION:**

- Tighten the wheel nuts in two or three steps by gradually increasing the torque and working diagonally, until the specified torque is reached. For drum brake models, excess tightening of wheel nuts may cause wheels to "judder".
- Do not depress the wrench with a foot; Always use both hands when tightening.
- Make sure the bolt, nut and the nut seating surface of the wheel are free from oils.

- 5) If a wheel is removed for replacement or for repair of a puncture, retighten the wheel nuts to the specified torque after running 1,000 km (600 miles).

### C: INSPECTION S204131A10

- 1) Deformation or damage on the rim can cause air leakage. Check the rim flange for deformation, crack, or damage, and repair or replace as necessary.
- 2) Jack-up vehicle until wheels clear the floor.
- 3) Slowly rotate wheel to check rim "runout" using a dial gauge.

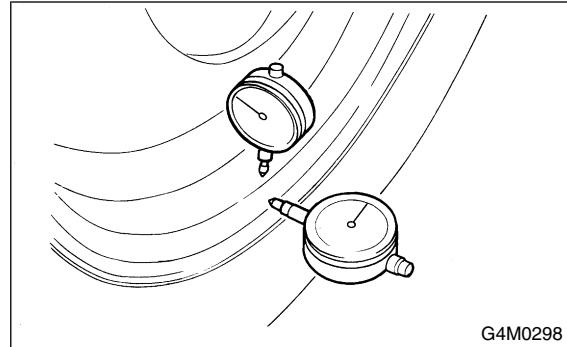

Axial runout limit	Radial runout limit
1.5 mm (0.059 in)	

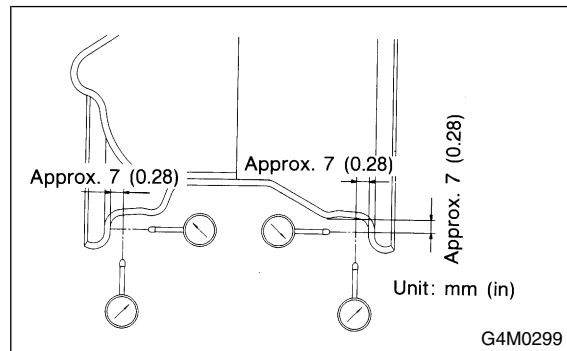

- 4) If rim runout exceeds specifications, remove tire from rim and check runout while attaching dial gauge to positions shown in figure.
- 5) If measured runout still exceeds specifications, replace the wheel.