

# LINE PRESSURE TEST

Automatic Transmission

## 7. Line Pressure Test S502244

### A: MEASUREMENT S502244A14

#### 1. GENERAL INFORMATION S502244A1401

If the clutch or the brake shows a sign of slippage or shifting sensation is not correct, the line pressure should be checked.

- Excessive shocks during upshifting or shifting takes place at a higher point than under normal circumstances, may be due to the line pressure being too high.

- Slippage or inability to operate the vehicle may, in most cases, be due to loss of oil pressure for the operation of the clutch, brake or control valve.

1) Line pressure measurement (under no load)

#### NOTE:

- Before measuring line pressure, jack-up all wheels.

- Maintain temperature of ATF at approximately 50°C (122°F) during measurement.

(ATF will reach the above temperature after idling the engine for approximately 30 minutes with select lever in "N" or "P".)

2) Line pressure measurement (under heavy load)

#### NOTE:

- Before measuring line pressure, apply both foot and parking brakes with all wheels chocked (Same as for "stall" test conditions).

- Measure line pressure when select lever is in "R", "2" with engine under stall conditions.

- Measure line pressure within 5 seconds after shifting the select lever to each position. (If line pressure needs to be measured again, allow the engine to idle and then stop. Wait for at least one minute before measurement.)

- Maintain the temperature of ATF at approximately 50°C (122°F) during measurement. (ATF will reach the above temperature after idling the engine for approximately 30 minutes with the select lever in "N" or "P".)

## 2. TEST METHODS S502244A1402

1) Temporarily attach the ST to a suitable place in the driver's compartment, remove the blind plug located in front of the toe board and pass the hose of the ST to the engine compartment.

ST 498575400 OIL PRESSURE GAUGE ASSY

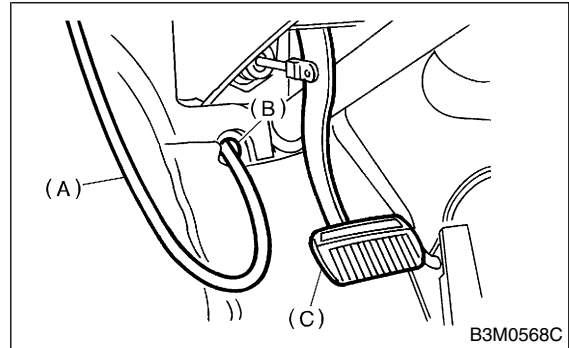

- (A) Pressure gauge hose
- (B) Hole in toe board (blank cap hole)
- (C) Brake pedal

2) Remove the test plug and install ST instead.

ST 498897200 OIL PRESSURE GAUGE ADAPTER

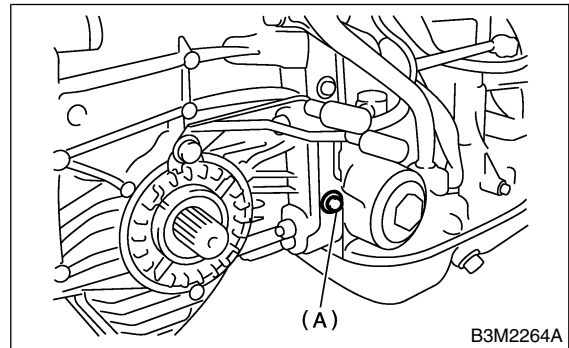

- (A) Test plug

3) Connect ST1 with ST2.

ST1 498897200 OIL PRESSURE GAUGE ADAPTER

ST2 498575400 OIL PRESSURE GAUGE ASSY

- 4) Check for duty ratio changes by opening and closing throttle valve using Subaru Select Monitor.  
 (1) Insert the cartridge to Subaru Select Monitor. <Ref. to AT-5, PREPARATION TOOL, General Description.>

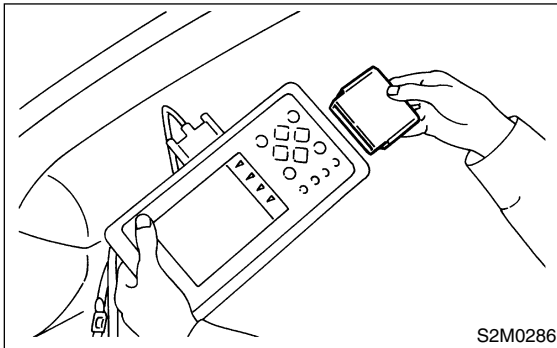

- (2) Connect Subaru Select Monitor to data link connector.  
 5) Check line pressure in accordance with the following chart.

### 3. EVALUATION S502244A1403

Standard line pressure			
Range position	Line pressure duty ratio (%)	Throttle position	Line pressure kPa (kg/cm <sup>2</sup> , psi)
2	5	Full open	1,128 — 1,304 (11.5 — 13.3, 164 — 189)
R	5	Full open	1,520 — 1,716 (15.5 — 17.5, 220 — 249)
D	100	Full closed	304 — 412 (3.1 — 4.2, 44 — 60)