

12. Inhibitor Switch S502243

A: INSPECTION S502243A10

When driving condition or starter motor operation is erroneous, first check the shift linkage for improper operation. If the shift linkage is functioning properly, check the inhibitor switch.

- 1) Disconnect inhibitor switch connector.
- 2) Check continuity in inhibitor switch circuits with select lever moved to each position.

NOTE:

- Also check that continuity in ignition circuit does not exist when select lever is in R, D, 3, 2 and 1 ranges.
- If inhibitor switch is inoperative, check for poor contact of connector on transmission side.

	Position	Pin No.
Signal sent to TCM	P	4 — 3
	R	4 — 2
	N	4 — 1
	D	4 — 8
	3	4 — 7
	2	4 — 6
	1	4 — 5
Ignition circuit	P/N	12 — 11
Back-up light circuit	R	10 — 9

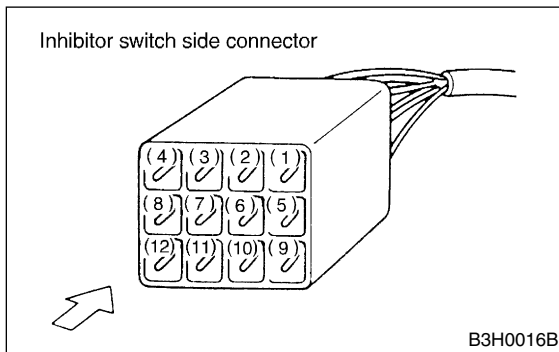

- 3) Check if there is continuity at equal points when the select lever is turned 1.5° in both directions from the N range.

If there is continuity in one direction and the continuity in the other or if there is continuity at unequal points, adjust the inhibitor switch. <Ref. to AT-29, ADJUSTMENT, Inhibitor Switch.>

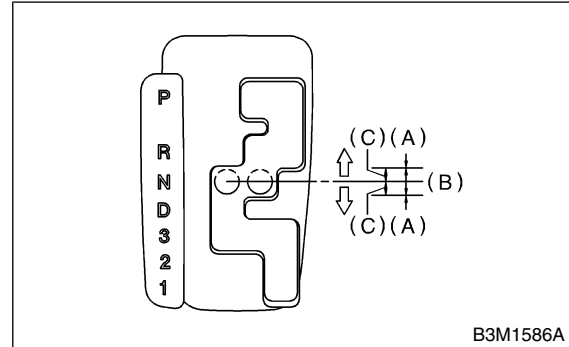

- (A) Continuity does not exist.
- (B) Continuity exists.
- (C) 1.5°

- 4) Repeat the above checks. If there are abnormalities, adjust the select cable. <Ref. to CS-27, ADJUSTMENT, Select Cable.>

B: ADJUSTMENT S502243A01

- 1) Loosen the three inhibitor switch securing bolts.
- 2) Shift the select lever to the N range.
- 3) Insert ST as vertical as possible into the holes in the inhibitor switch lever and switch body.
ST 499267300 STOPPER PIN

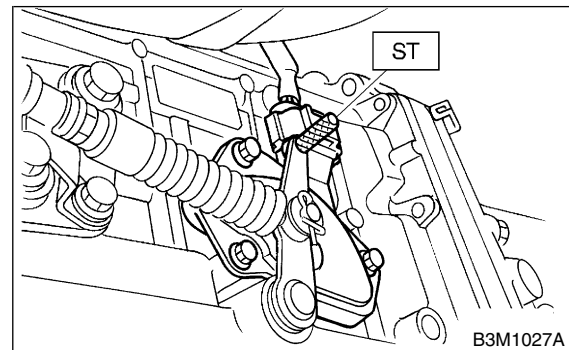

- 4) Tighten the three inhibitor switch bolts.

Tightening torque:

3.5 N·m (0.36 kgf·m, 2.6 ft·lb)

- 5) Repeat the above checks. If the inhibitor switch is determined to be “faulty”, replace it.

INHIBITOR SWITCH

Automatic Transmission

C: REMOVAL S502243A18

- 1) Move select lever to neutral position.
- 2) Remove air cleaner case or air intake chamber.
2.5 L model
<Ref. to IN-6, REMOVAL, Air Cleaner Case.>
3.0 L model
<Ref. to IN(H6)-6, REMOVAL, Air Intake Chamber.>
- 3) Disconnect inhibitor switch connector.

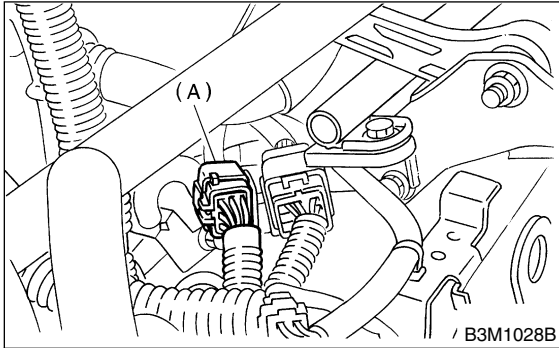

(A) Inhibitor switch

- 4) Remove front exhaust pipe with center exhaust pipe.
2.5 L model
<Ref. to EX-5, REMOVAL, Front Exhaust Pipe.>
3.0 L model
<Ref. to EX(H6)-5, REMOVAL, Front Exhaust Pipe.>
- 5) Remove snap pin from range select lever.

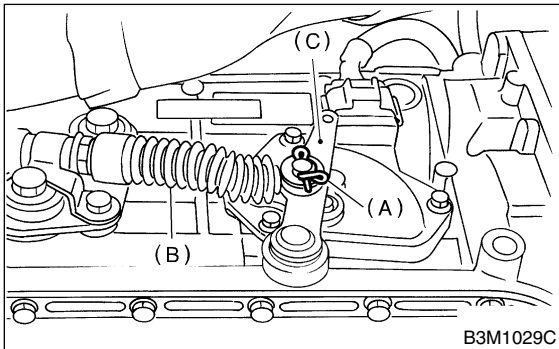

- (A) Snap pin
(B) Select cable
(C) Range select lever

- 6) Remove plate assembly from transmission case.

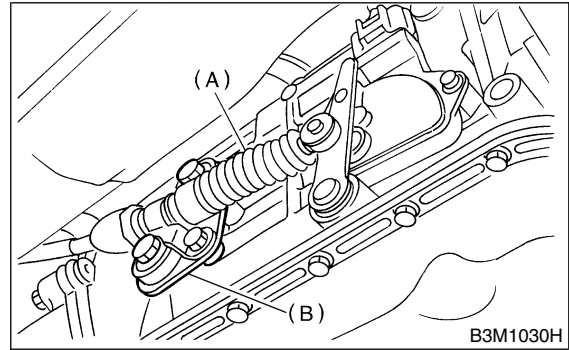

- (A) Select cable
(B) Plate ASSY

- 7) Remove bolts.

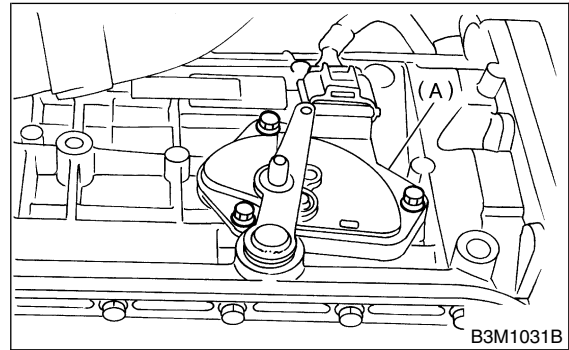

(A) Inhibitor switch

- 8) Move range select lever to parking position (left side).

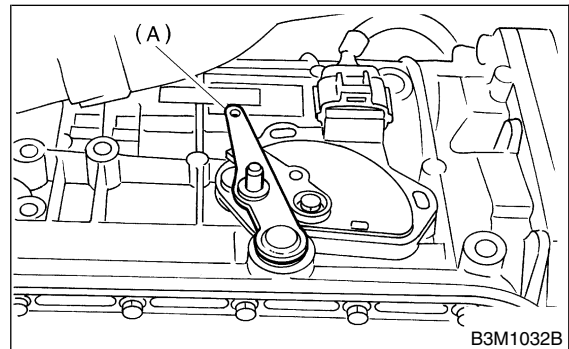

(A) Range select lever

9) Remove inhibitor switch from transmission.

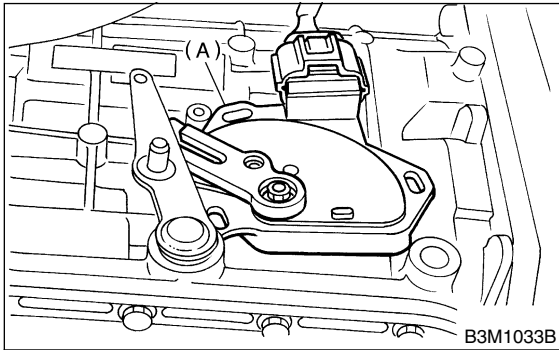

(A) Inhibitor switch

10) Disconnect inhibitor switch harness connector from inhibitor switch.

D: INSTALLATION

S502243A11

1) Connect inhibitor switch harness connector to inhibitor switch.

2) Install inhibitor switch to transmission case.

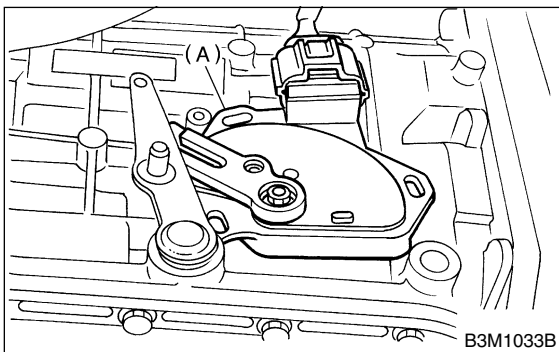

(A) Inhibitor switch

3) Move range select lever to neutral position.

4) Using ST, tighten bolts of inhibitor switch.

ST 499267300 STOPPER PIN

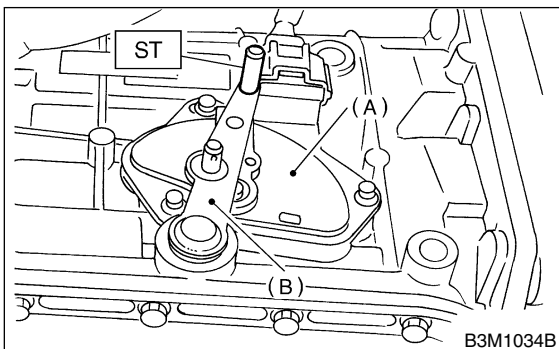

(A) Inhibitor switch
(B) Range select lever

5) Install select cable to range select lever.

6) Install plate assembly to transmission.

Tightening torque:

T: 24.5 N·m (2.50 kgf·m, 18.1 ft·lb)

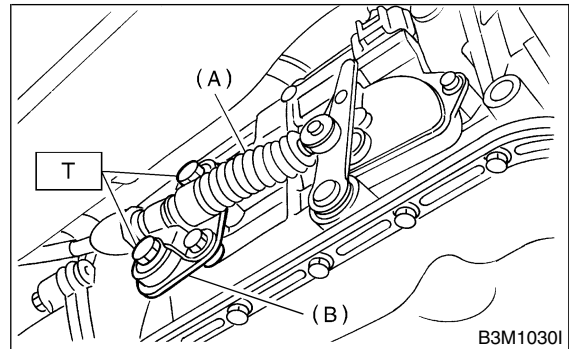

(A) Select cable
(B) Plate ASSY

7) Install snap pin to range select lever.

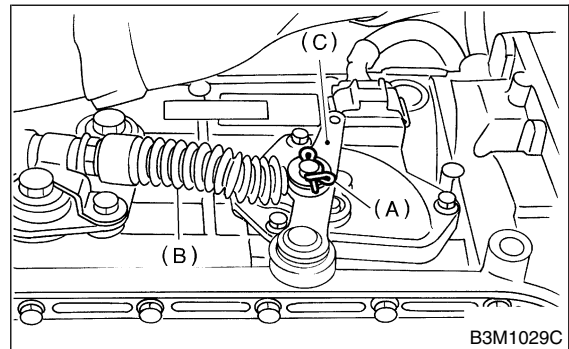

(A) Snap ring
(B) Select cable
(C) Range select lever

INHIBITOR SWITCH

Automatic Transmission

8) Install front exhaust pipe and center exhaust pipe.

2.5 L model

<Ref. to EX-6, INSTALLATION, Front Exhaust Pipe.>

3.0 L model

<Ref. to EX(H6)-6, INSTALLATION, Front Exhaust Pipe.>

9) Connect inhibitor switch connector.

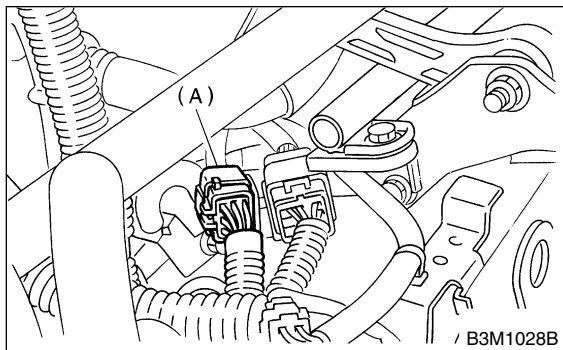

(A) Inhibitor switch

10) Install air cleaner case or air intake chamber.

2.5 L model

<Ref. to IN-6, INSTALLATION, Air Cleaner Case.>

3.0 L model

<Ref. to IN(H6)-6, INSTALLATION, Air Intake Chamber.>

11) Inspect inhibitor switch. <Ref. to AT-29, INSPECTION, Inhibitor Switch.>